

**Beckett Bridge PD&E Study**  
**Meeting with City of Tarpon Springs Staff**  
**September 13, 2012**  
**Agenda**

**Date:** September 13, 2012

**Time:** 3:30 pm

**Location:** Pinellas County Utilities Building, 6<sup>th</sup> Floor Conference Room,

**A. Review Alternatives Developed (Plan/Profile)**

- a. Permanent Removal of Bridge
- b. Construction of New Low-Level Movable Bridge
- c. Construction of New Mid-Level Fixed Bridge
  - i. Option A
  - ii. Option B

**B. Possible Meeting with City of Tarpon Springs Commission**

**C. City Resident Representative for Cultural Resource Committee**

**E. Project Schedule**

# Meeting Notes



**Date:** September 13, 2012

**Time:** 3:00 pm

**Place:** Pinellas County Utilities Building, 6<sup>th</sup> Floor Conference Room,

**RE:** Beckett Bridge PD&E Study- Coordination Meeting

**Recorded by:** Ann Venables

**Attendees:** Tony Horrnik, Pinellas County  
Tom Washburn, Pinellas County  
Tom Funcheon, City of Tarpon Springs  
Gary Schurman, City of Tarpon Springs  
Jim Phillips, EC Driver  
Ann Venables, EC Driver

---

## **Purpose**

The purpose of the meeting was to coordinate the alternatives developed to date with City staff .

## **Summary of Discussion**

### *Review of Alternative Concept Plans*

Jim Phillips reviewed the alternative concept plans developed for removal or replacement of the existing bridge. (Note: The No-Build alternative will be considered a viable alternative throughout the study.) The following alternatives were discussed:

- No-Build with Permanent Removal of the Bridge
- Rehabilitation
- Replacement with a Low-Level Movable Bridge
- Replacement with a Mid-Level Fixed Bridge (with 27' 8 ½" of vertical clearance)
  - Option A
  - Option B

Issues including proposed grade, potential impacts to property, drainage issues and design were discussed for each alternative.

The Low-level movable bridge alternative can be constructed within existing right-of-way, assuming that no stormwater ponds would be constructed within the project corridor.

Options A and B for the Mid-Level fixed bridge alternative would have substantial right-of-way impacts. Proposed retaining walls would impact access to Riverside Drive for adjacent properties. Both options propose construction of access roads to preserve access to the Bayshore Mobile Home Park and to maintain the connection between Pampas Avenue and Venetian Court.

The maximum vertical clearance over the navigation channel proposed is 27' 8 ½" for the mid-level option. Higher vertical clearance would result in substantial impacts to the intersections of Chesapeake Drive and Forest Avenue with Riverside Drive, and construction would extend beyond the project limits.

### *Comments by Tom Funcheon and Gary Schurman*

Tom and Gary discussed the drainage problems within the project corridor, particularly near Chesapeake Drive. Both indicated that the addition of a stormwater pond on the north side of

Meeting Minutes  
September 13, 2012

Riverside Drive and/or located on the empty lot adjacent to the Tarpon Springs Yacht Club would be advantageous and suggested that it be added to the low-level bridge alternative plans.

Tom and Gary also believe there is an existing drainage pipe on the south side of Riverside Drive between Chesapeake Drive and the bridge that may be silted in. They would appreciate additional information on the condition of this pipe if available.

Gary noted that there is a driveway and garage on the south side of the road just west of Forest Avenue that may present grade challenges.

*Community Involvement*

Tom and Gary agreed that all of the alternatives developed, including the mid-level options should be presented at the Community Workshop.

Tom and Gary stated that the project team is encouraged to make a presentation to the City Commission that summarizes the alternatives to be presented at the Community Workshop.

Gary suggested contacting Karen Lemons, the City's new Development Director to inquire about a possible neighborhood representative for the Cultural Resource Committee (CRC).

Gary also stated that Gwen Neil publishes a newsletter for homeowners along Chesapeake Drive, although there is no organized homeowner association in that area. He will provide her contact information.



City of Tarpon Springs

...Where Culture and Fun Collide

[HOME](#) [MAYOR/COMMISSIONERS](#) [AGENDA](#) [BOARDS & COMMITTEES](#) [VIDEO LIBRARY](#) [AUTO PAY](#) [EVENT CALENDAR](#)



[MAYOR DAVID O. ARCHIE](#)  
[VICE-MAYOR SLATTERY](#)  
[COMMISSIONER LARSEN](#)  
[COMMISSIONER TARAPANI](#)  
[COMMISSIONER BANTHER](#)

[EMAIL THE MAYOR AND COMMISSIONERS](#)

\*\*\*\*\*

**REGULAR SESSION AGENDA  
TUESDAY, OCTOBER 1, 2013  
6:30 P.M.**

\*\*\*\*\*

**CALL TO ORDER**  
**ROLL CALL**  
**INVOCATION**  
**PLEDGE OF ALLEGIANCE**  
**PUBLIC COMMENTS**

**PROCLAMATION(S):**  
1. [NATIONAL BREAST CANCER AWARENESS MONTH](#)

**PRESENTATION(S):**  
2. FLORIDA GREEN BUILDING COALITION: SUZANNE COOK; SILVER RECERTIFICATION  
3. P-TEC PRESENTATION; ROLAND BRYANT AND RAY GORMAN  
4. [BECKETT BRIDGE PROJECT UPDATE](#): ANN VENABLES, PROJECT MANAGER, URS CORPORATION AND TONY HORNIK, PROJECT MANAGER,

*CITY DEPARTMENTS*

- [CEMETERY](#)
- [CITY CLERK](#)
- [CITY MANAGER](#)
- [CODE ENFORCEMENT](#)
- [CULTURAL SERVICES](#)
- [DEVELOPMENT SERVICES](#)
- [ECONOMIC DEVELOPMENT](#)
- [EMERGENCY MANAGEMENT](#)
- [FINANCE](#)
- [FIRE RESCUE](#)
- [GOLF COURSE](#)
- [HUMAN RESOURCES](#)
- [LIBRARY](#)
- [MARINA](#)
- [MAYOR/COMMISSION](#)
- [POLICE DEPARTMENT](#)
- [PARKS MAINTENANCE](#)
- [PUBLIC SERVICES](#)

EMAIL THE CITY MANAGER

CITY MANAGER  
PRESENTATIONS

COMMISSION AGENDA

BOARDS AND COMMITTEES

VIDEO LIBRARY

324 E. PINE STREET  
TARPON SPRINGS, FL 34689  
TELEPHONE: 727-938-3711  
FAX: 727-937-8199

PINELLAS COUNTY

**CONSENT AGENDA:**

5. MINUTES:

- A. AUGUST 6, 2013 REGULAR SESSION
- B. AUGUST 12, 2013 BUDGET WORK SESSION
- C. AUGUST 20, 2013 REGULAR SESSION
- D. SEPTEMBER 3, 2013 REGULAR SESSION
- E. SEPTEMBER 12, 2013 SPECIAL SESSION – PUBLIC HEARING
- F. SEPTEMBER 17, 2013 REGULAR SESSION
- G. SEPTEMBER 23, 2013 SPECIAL SESSION – PUBLIC HEARING
- H. SEPTEMBER 23, 2013 SPECIAL SESSION

6. SATISFACTION AND RELEASE OF LIENS

7. ATTORNEY'S FEES:

A. FRAZER HUBBARD BRANDT TRASK YACAVONE METZ & DIAGNEAULT, LLP: INVOICE # 43384

B. THOMPSON SIZEMORE GONZALEZ & HEARING, LLP: INVOICE # 71557

8. SPECIAL EVENTS:

A. N. SAFFORD/FITNESS PARK/ DOG PARK GRAND OPENING; ZOMBIE RUN AND HALLOWEEN FAMILY FUN DAY – CITY OF TARPON SPRINGS: 10-19-2013

B. ANTIQUE & TREASURE SALE – CHAMBER OF COMMERCE: 11-16-2013

C. GREEK FOOD AND WINE FESTIVAL – ST. NICHOLAS GREEK ORTHODOX CATHEDRAL: 11-15, 16, 17-2013

9. INCREASE FILE NO. 130009-C-JJ: TELEPHONY EQUIPMENT & SERVICES

10. RENEW FILE NO. 120122-N-JJ: MAINTENANCE OF PUBLIC RESTROOMS AT THE SPONGE EXCHANGE

**SPECIAL CONSENT AGENDA:**

11. REQUEST FOR APPRAISAL – JEFFERSON BANK BUILDING PARKING LOT

12. INCREASE RFP NO. 090100-P: JOB ORDER CONTRACTING

**ORDINANCES AND RESOLUTIONS:**

13. RESOLUTION 2013-47: APPLICATION 13-52 KEYSTONE RIDGE ESTATES SITE PLAN APPLICATION, KEYSTONE ROAD AT MELON STREET

14. ORDINANCE 2013-23: AMENDING THE COMPREHENSIVE ZONING AND LAND DEVELOPMENT CODE AND CRA AND SPONGE DOCKS SMARTCODE TO PROVIDE FOR DOGS IN PUBLIC FOOD SERVICE ESTABLISHMENTS (1ST READING)

15. RESOLUTION 2013-48: APPLICATION 13-52 A PLAYCE FOR PUPS; CONDITIONAL USE APPLICATION TO ALLOW OVERNIGHT BOARDING OF ANIMALS AT 39930 U.S. HIGHWAY 19 NORTH

PUBLIC WORKS

PURCHASING

RECREATION

ROADS & STREETS

SANITATION & RECYCLING

TREATMENT PLANT

UTILITY BILLING

WATER DISTRIBUTION & SEWAGE COLLECTION

WATER DIVISION

**BOARD AND STAFF COMMENTS:  
ADJOURNMENT**

\*\*\*\*\*

**NEXT MEETINGS:**

\*\*\*\*\*

**TUESDAY, OCTOBER 15, 2013 - 6:30 PM - REGULAR SESSION**

**TUESDAY, NOVEMBER 5, 2013 - 6:30 PM - REGULAR SESSION**

**TUESDAY, NOVEMBER 19, 2013 - 6:30 PM - REGULAR SESSION**

**TUESDAY, DECEMBER 3, 2013 - 6:30 PM - REGULAR SESSION**

**TUESDAY, DECEMBER 17, 2013 - 6:30 PM - REGULAR SESSION**

\*\*\*\*\*

\*\*\*\*\*

**CITY OF TARPON SPRINGS BOARD OF COMMISSIONERS  
RULES OF PROCEDURE**

\*\*\*\*\*

**PUBLIC COMMENT:**

No speaker shall have the right to address the Board of Commissioners for more than four (4) minutes on any particular item. Members of the public present at the meeting may donate their time to a speaker to extend the speaker's time but such donation shall forfeit the donator's right to speak. The speaker shall identify the persons who have donated their speaking time. Each donation shall extend the speaker's time an additional two (2) minutes. In no event shall the speaker's time be extended beyond ten (10) minutes of total speaking time. Any deviation from this rule must be approved by the consensus of a majority of the Board, but no vote need be taken to waive this requirement.

Each person addressing the City Commission shall approach the podium, shall give his or her name and address in an audible tone of voice. All remarks shall be addressed to the City Commission as a body, and not to any member thereof. All speakers, including City Commissioners, shall be recognized by the Mayor. No person, other than members of the City Commission and the person having the floor shall be permitted to enter into any discussion, either directly or through members of the City Commission. No questions

shall be asked to individual Commission members, except through the Mayor. Any person making personal, impertinent, or slanderous remarks, or who shall become boisterous while addressing the City Commission may be requested to leave the meeting and may forthwith be barred from further audience at that meeting.

**PRESERVATION OF ORDER:**

The Mayor shall preserve order and decorum, and shall prevent attacks on personalities or impugning of motives of particular members, and shall prevent digression from the question under discussion. The Mayor shall ensure that no boisterous conduct, such as cheering, clapping, or the like shall be permitted during debate. The Chief of Police or his or her designate shall be the sergeant-at-arms of the City Commission.

**APPEALS AND RECORD OF PROCEEDINGS:**

If any person decides to appeal any decision made by the Board of Commissioners with respect to any matter considered at this meeting, he/she will need a record of the proceedings, and that for such purpose, he/she may need to ensure a verbatim record of the proceedings is made, which record includes the testimony and evidence upon which the appeal is to be based. The City of Tarpon Spring does not furnish verbatim transcripts. Interested parties should make necessary arrangements for the verbatim transcript in advance.

**ACCOMMODATION FOR PERSONS WITH DISABILITIES:**

Any person with a disability requiring reasonable accommodation in order to participate in this meeting should call 727-938-3711 or fax a written request to 727-937-8199.

\*\*\*\*\*  
\*\*\*\*\*  
\*\*\*\*\*  
\*\*\*\*\*

[JOB OPPORTUNITIES](#)

[CONTACT US](#)

[HISTORY](#)

[CHANNEL 15](#)

[EMAIL NEWS LETTER](#)

[FAQ](#)

[CHAMBER OF COMMERCE](#)



# Beckett Bridge PD& E Study

Presentation to:

City of Tarpon Springs Commission



October 1, 2013



# Project Location

2012 AADT  
7,700 vehicles

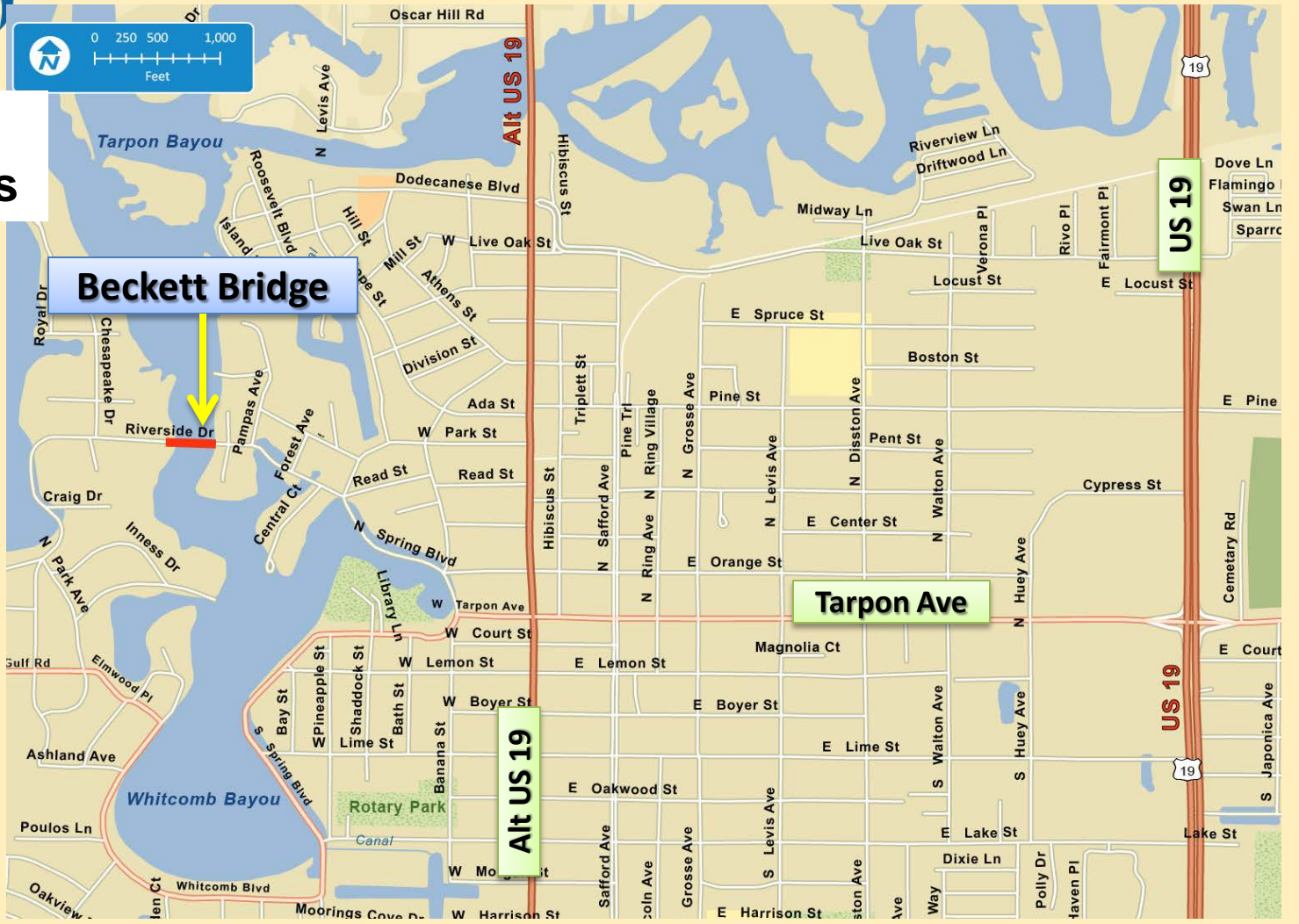



- **Constructed 1924**
  - Original timber construction
- **Substantially Rehabilitated 1956**
  - Original steel bascule span and machinery retained
- **Major Repairs in 1979, 1998 and 2011**
  - Machinery replaced “in-kind”
- **Sufficiency Rating 44.7**



- **Functionally Obsolete**

- **Narrow Lanes**

- No Shoulders
- No bicycle lanes

- **Narrow Sidewalks**

- Do Not Meet ADA Requirements

- **Structural Deficiencies**

- **Load Posted**

- **Not designed for current heavier vehicles**



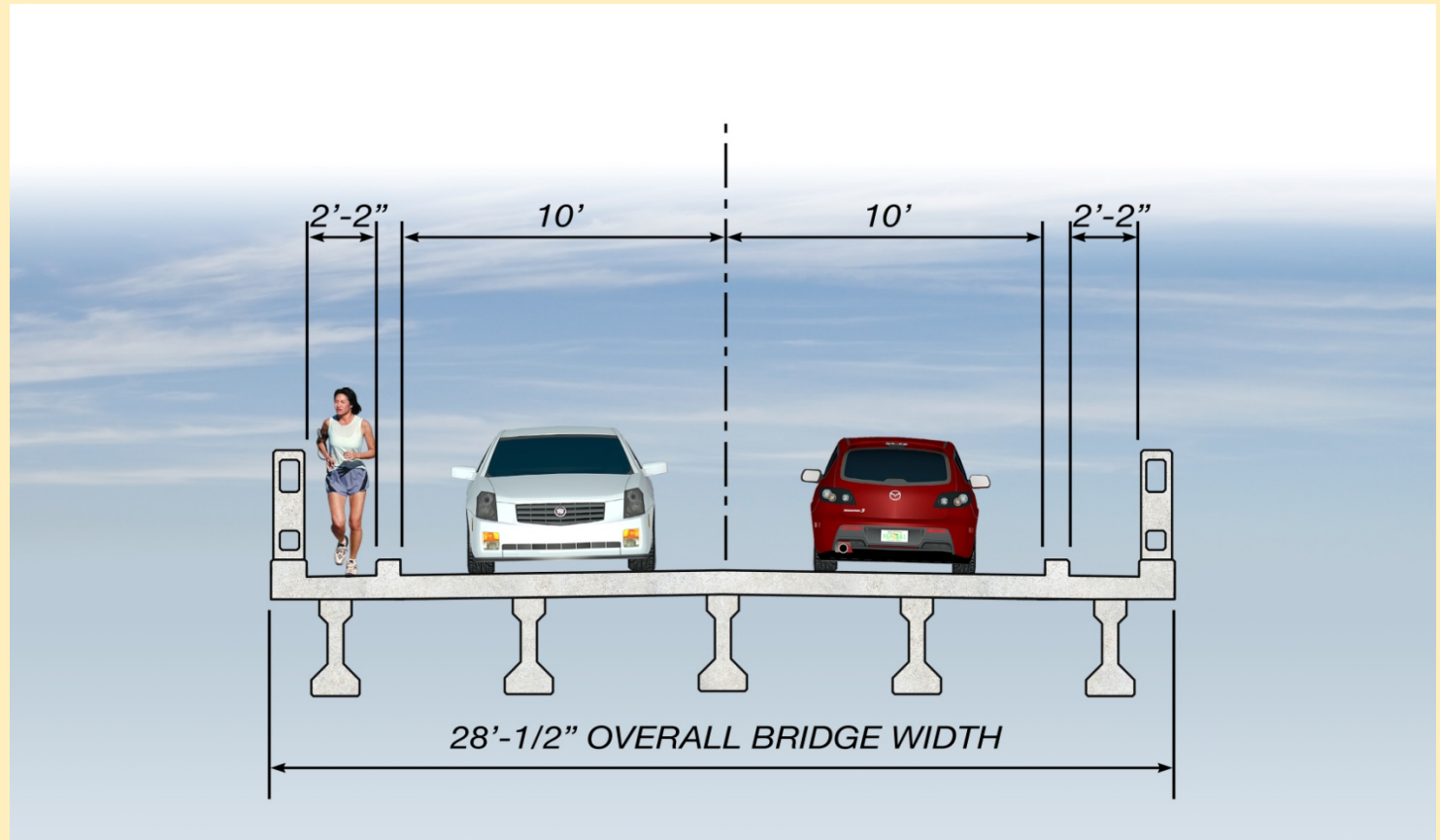

**No Shoulders**

**Narrow Sidewalks**

- **Determined Eligible for listing in the National Register of Historic Places**
  - One of a few remaining pre-1965, Single-Leaf Rolling-Lift Bascule Highway Bridges in Florida
  - Eligible in Areas of Community Planning and Development, Transportation and Engineering
  - Contributed to Westward Expansion of the City of Tarpon Springs

- Vertical Clearance – 6 ft
- Horizontal Clearance – 25 ft
- Opens with 2-hr Notice

**Total # Bridge Openings**

**2009 - 10**

**2010 - 20**

**2011 - 18**

**2012 - 14**





## **Study Began January 2012**

### **Alternatives Considered**

- **No-Build**
- **No-Build with Permanent Removal of Existing Bridge**
- **Rehabilitation (No Widening)**
- **Replacement**
  - **Fixed Bridge – 28 feet Vertical Clearance**
  - **Movable Bridge - 7.8 feet Vertical Clearance**

## Stakeholder/Local Government Presentations October – November 2012

- Chamber of Commerce
- Rotary Club
- Tarpon Springs Yacht Club
- MPO Board
- MPO Advisory Committees
- City of Tarpon Springs
- Pinellas County BCC
- Cultural Resource Committee (CRC)





- Alternatives Public Meeting - January 2013  
77 Written Comments Received

## *Preferences for Alternatives*

<b>No-Build</b>	<b>7</b>
<b>No-Build, Remove Bridge</b>	<b>2</b>
<b>Rehabilitation</b>	<b>11</b>
<b>Rehabilitation or New Movable</b>	<b>12</b>
<b>New Movable Bridge</b>	<b>32</b>
<b>New Fixed Bridge</b> (28 ft Vertical Clearance)	<b>4</b>

- **Alternatives Public Meeting - January 2013**

- Community Concerns**

- **Need for safer pedestrian facilities**
    - **Bridge should provide adequate vertical clearance**
    - **Bridge should not adversely affect historic character of the community**
    - **Duration of detour should be minimized**



## CRC Meeting – March 2013

SHP0 requested evaluation of two new Rehabilitation Alternatives with Improved Sidewalks

- **Rehabilitation with Widening**
  - Provide sidewalks on both sides
- **Reconfiguration of Existing Bridge (No Widening)**
  - Provide sidewalk on one side



# Existing Bascule Typical Section

**26'- 8" Total Width**

10 ft lanes, no shoulders

2'3" sidewalks

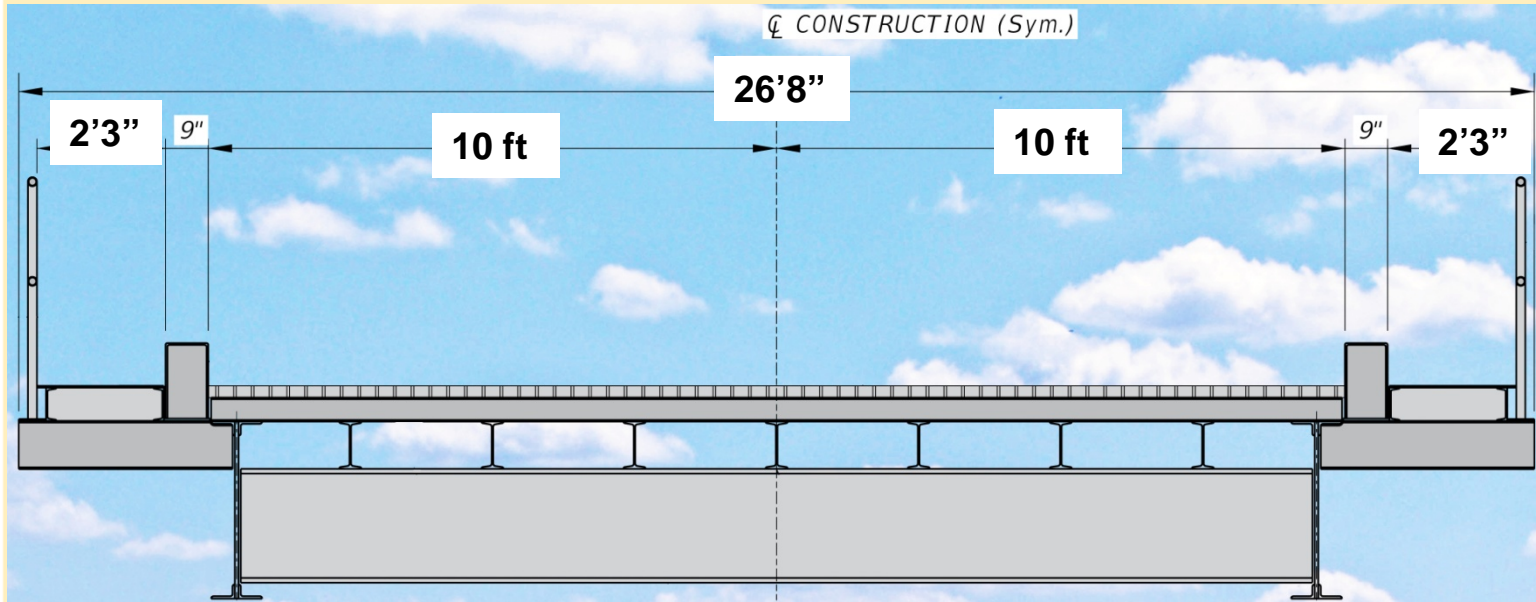

## Established Minimum Acceptable Typical Section

**Total Width - 42 feet**

- 5'6" sidewalks - both sides
- 11 ft lanes
- 3 ft shoulders

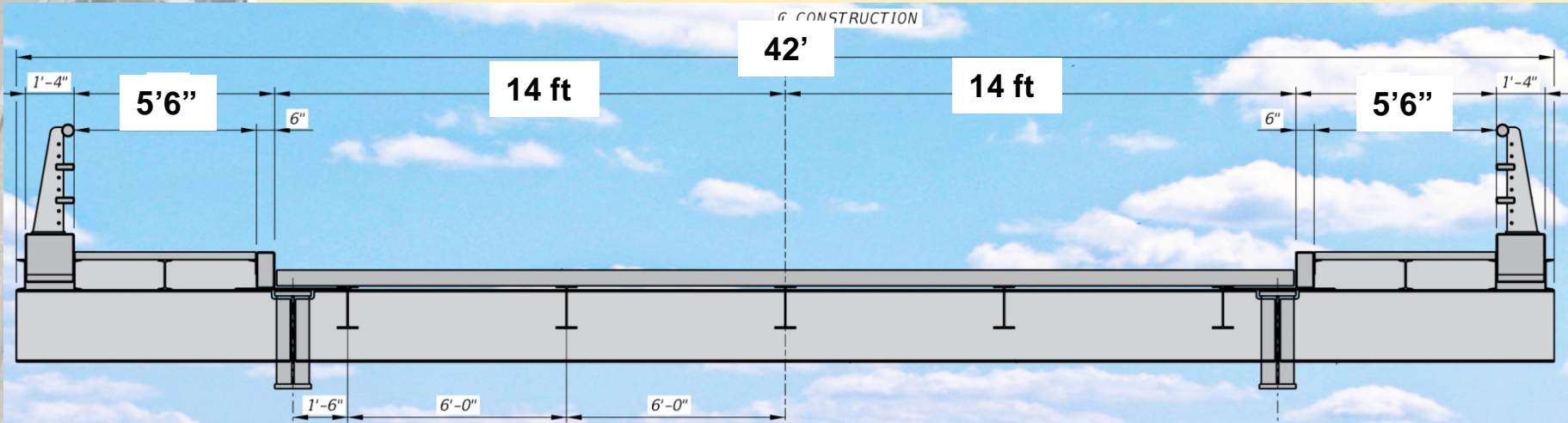

## Conclusions of Detailed Engineering Analysis

- Widening the bridge to provide improved sidewalks requires replacement of
  - Movable (Bascule) Span
  - Bascule piers which support the span
- No elements of the original bridge would remain





Rehabilitation with reconfiguration of existing bridge to provide one 5.5' wide sidewalk without widening existing bridge

## Conclusions of Detailed Engineering Analysis

- Not feasible – Minimum typical section requires 32.1 feet – Approximately 4 feet wider than existing
- Widening would require replacement of bascule spans and piers
- No elements of the original bridge would remain

## Costs

**Original Rehabilitation Concept - \$9.5 M**

(No Widening/No Sidewalk Improvements)

**Rehabilitation (with Widening) - \$12.5 M**

(Widened to provide two 5.5 ft wide sidewalks)

**Reconfiguration of Existing Bridge**

(No widening, one 5.5 ft wide sidewalk)

**Not Feasible**

**New Movable Bridge - \$15.8 M**

(Provides two 6 ft sidewalks)

## Costs Compared over a 100 Year Period

- Rehabilitate the bridge in 2020 then replace it with a new movable bridge in 2038  
(25 years from 2013)

Versus

- Replace the bridge in 2020 with a new movable bridge

**Result - More Cost Effective to Replace Bridge in 2020**

## SHPO Determinations

- Engineering Analysis provides “*ample evidence*” to support the project team’s opinion that a new bridge would be preferable to the rehabilitation.”
- Mitigation will be required if existing bridge is demolished

## Description

- No right-of-way impacts
- Vertical Clearance 7.8 feet
  - (existing 6 feet)
- Horizontal Clearance 25 feet
  - (same as existing)
- Total Width 47.2 feet
  - Approximately 19 feet wider than existing
  - 11 ft travel lanes
  - 5.5 ft shoulders and 6 foot sidewalks – both sides

**Total Bridge Width - 47.2 feet**

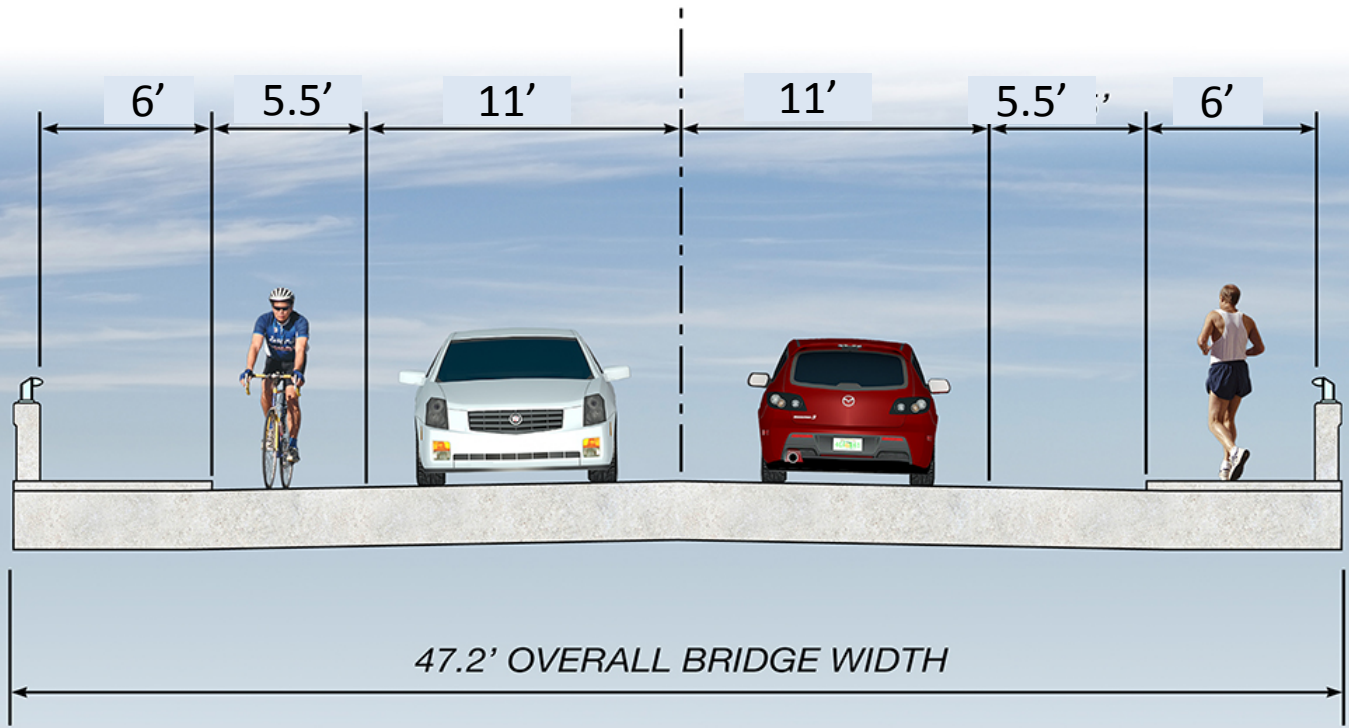

# Pinellas County Proposed Roadway Typical Section – East of Movable Bridge

Total Width – 46 feet

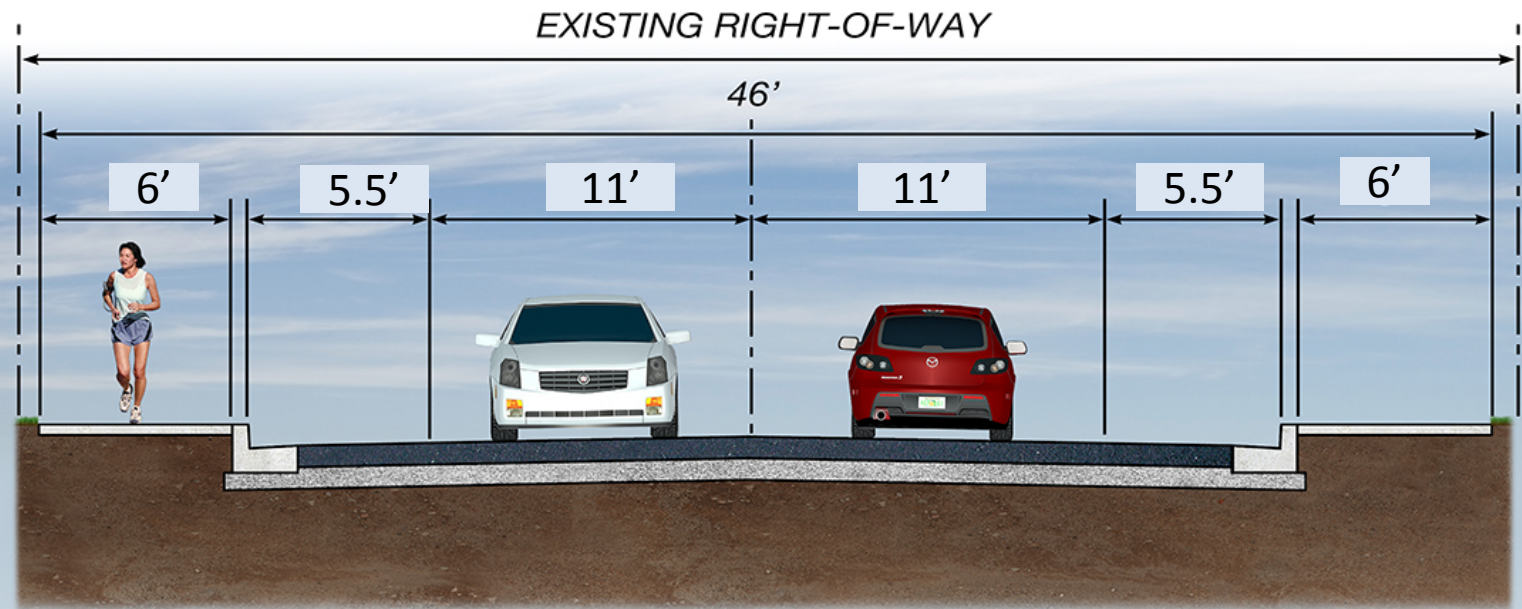



# Proposed Roadway Typical Section – West of Movable Bridge

Total Width – 38 feet

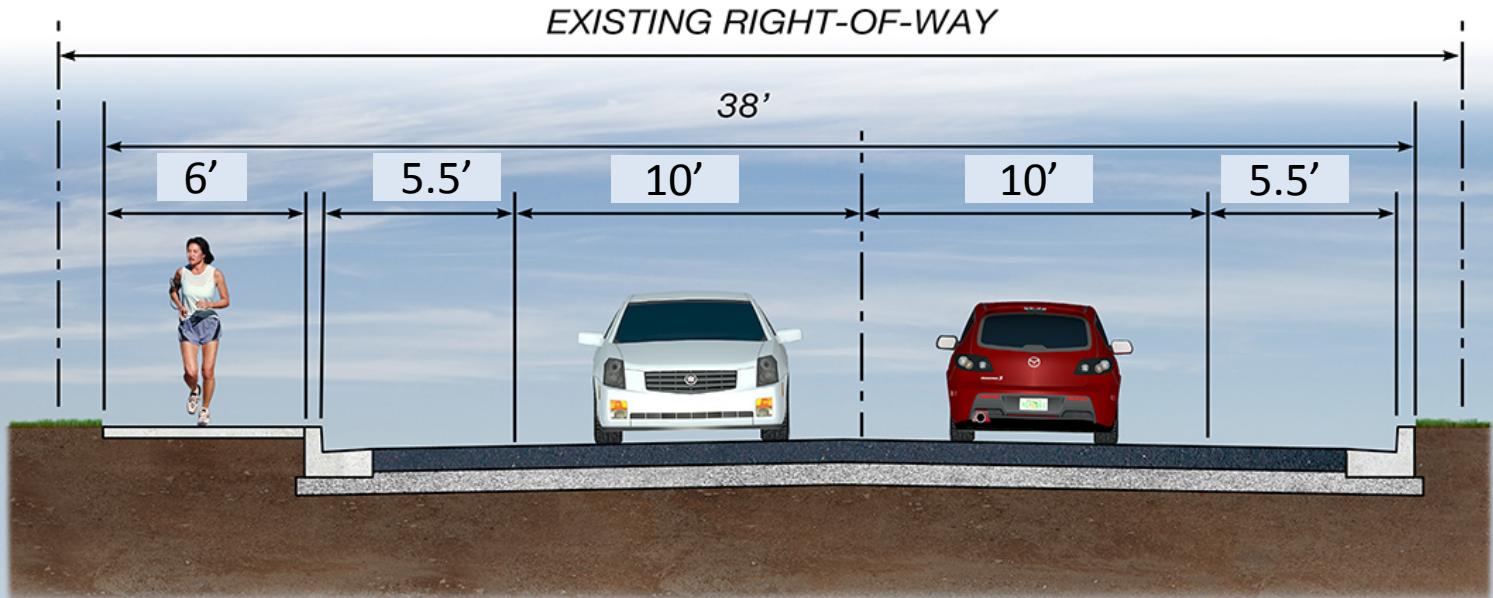





# New Movable Bridge Aesthetics

Period appropriate aesthetic styles common in  
Scherzer Rolling-Lift Bridges constructed  
between 1920 and 1945

- **Industrial**
- **Moderne**



# View from Dock Northwest of Bridge

## Existing Bridge





## “Industrial” Style Rolling-Lift Bascule Bridge





# View from Dock Northwest of Bridge

## “Generic” Movable Bridge



## “Industrial” Style Rolling-Lift Bascule Bridge



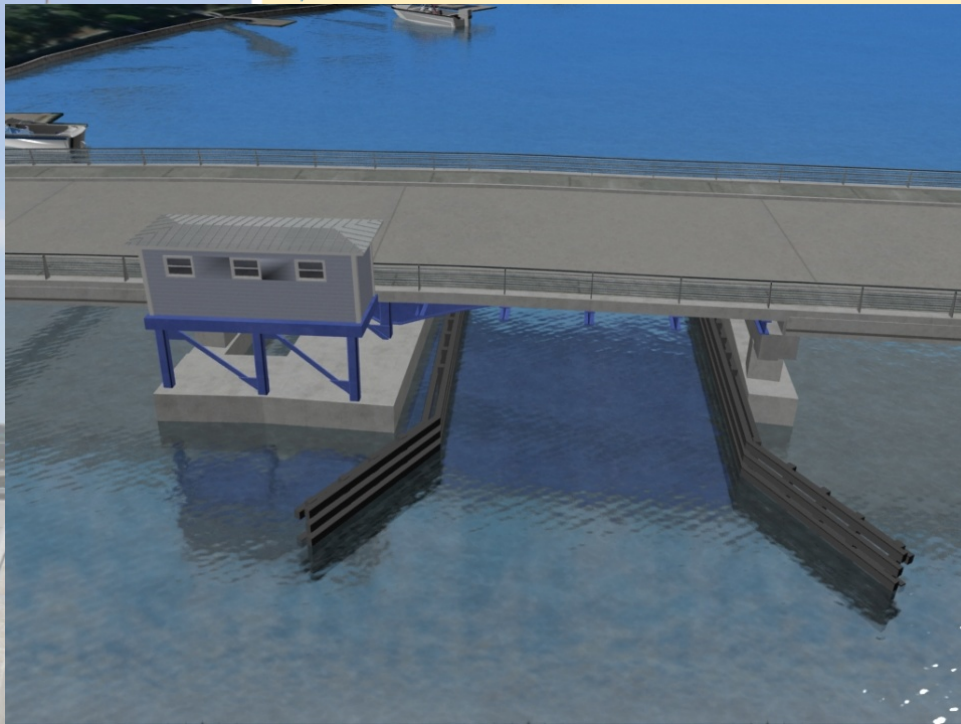

**3D Model Views  
Industrial Style**

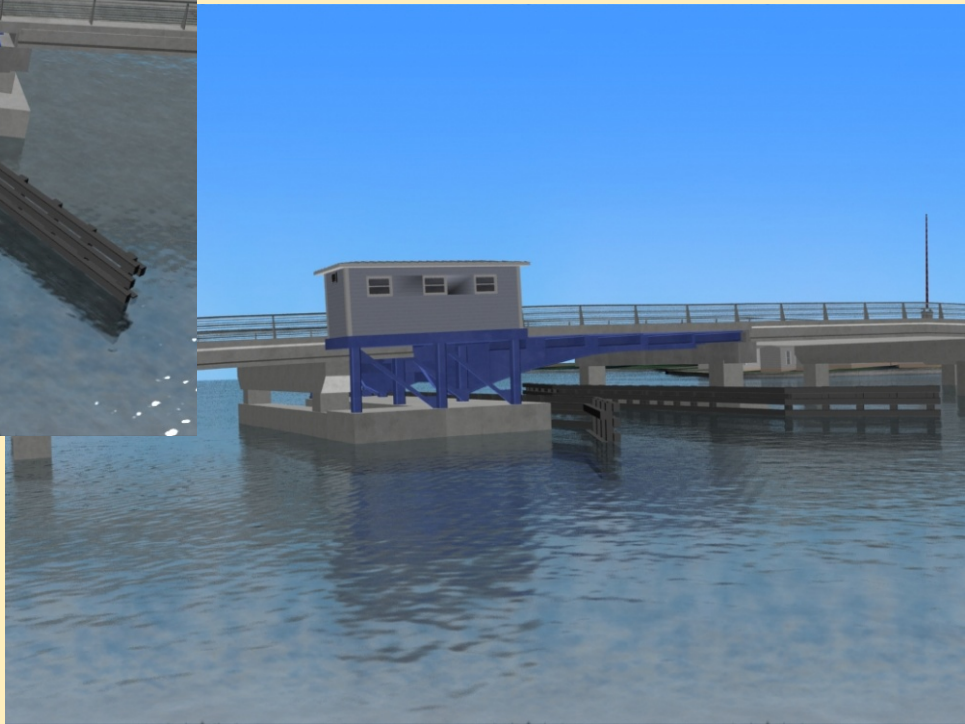

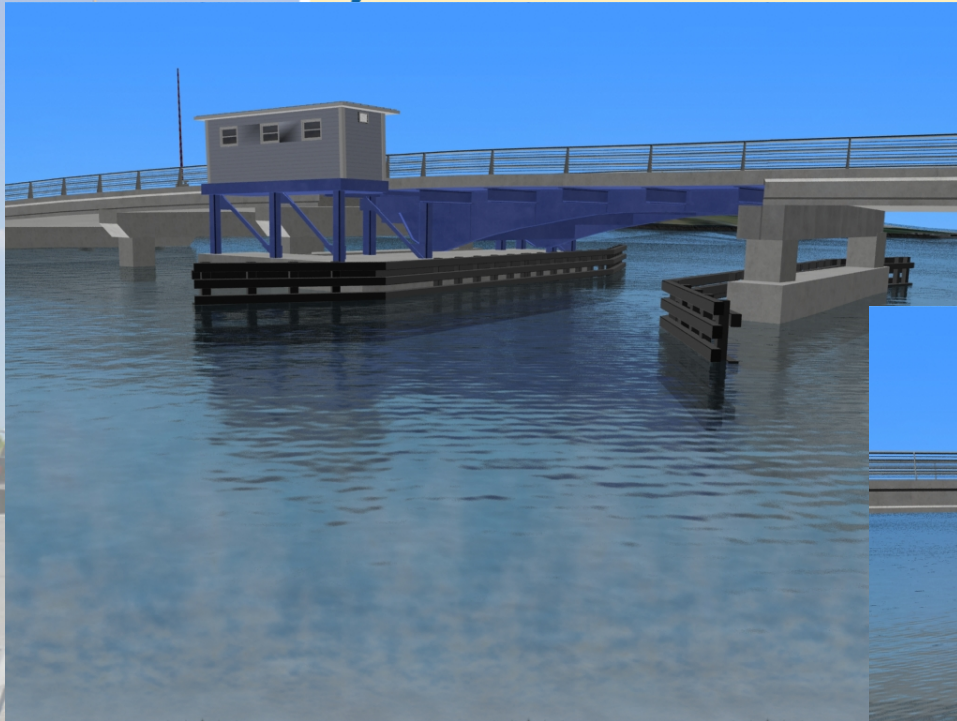

## 3D Model Views Industrial Style

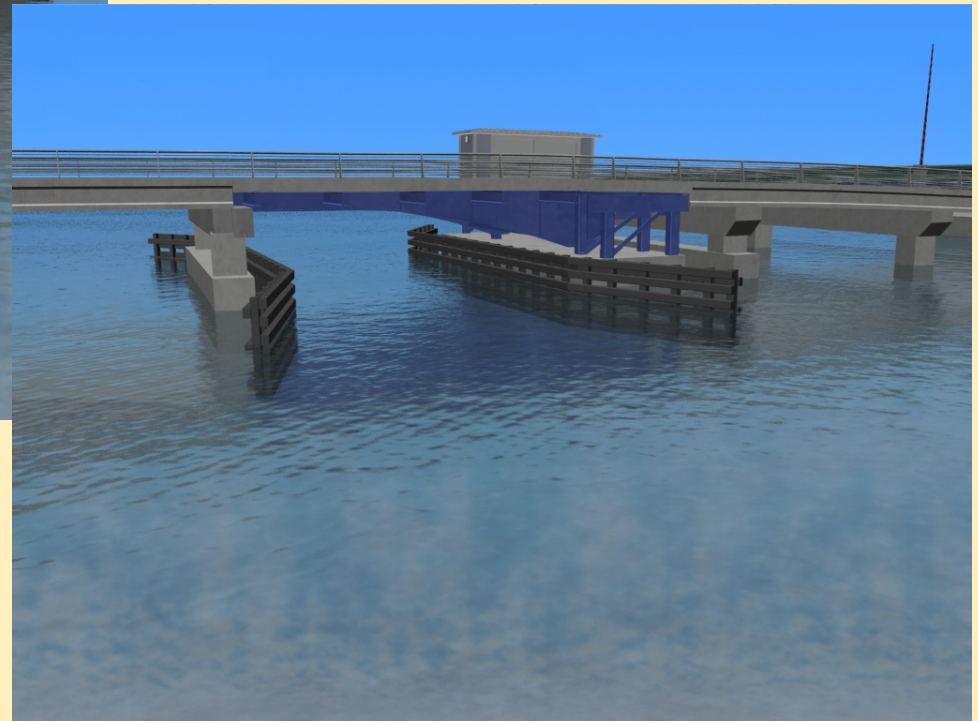

**Other -Historic Rolling Lift Bridges**



**Black River, MI (1929)**

**Jackson St., Joliet, MI (1933)**





## Other -Historic Rolling Lift Bridges - Moderne

Main Street, Niagara Ontario (Unknown Yr.)



**Other -Historic Rolling Lift Bridges - Moderne**

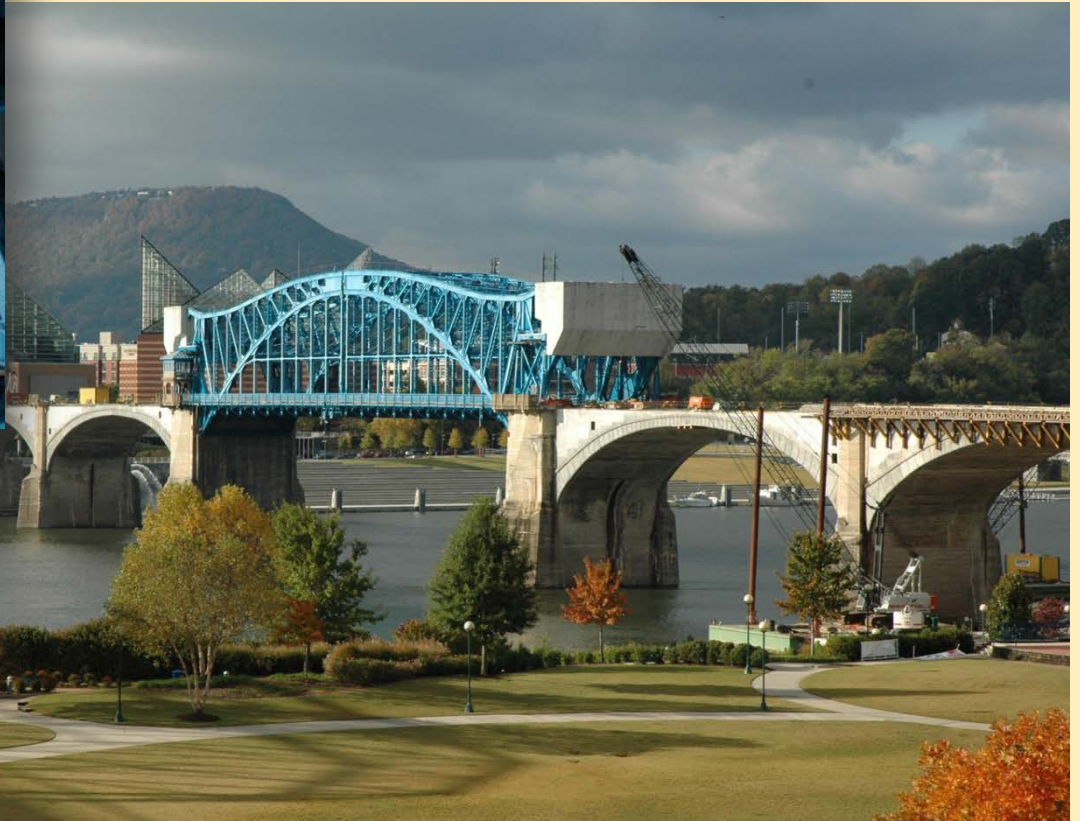

**Market Street, Chattanooga, TN (1917)**

**Other -Historic Rolling Lift Bridges**



**Ortega River Bridge,  
Jacksonville, FL (1927)**





## Required Mitigation

### Historic American Engineering Record (HAER) Documentation

- Large format photographs
- Written history/narrative
- Historic bridge plans copied on archival paper

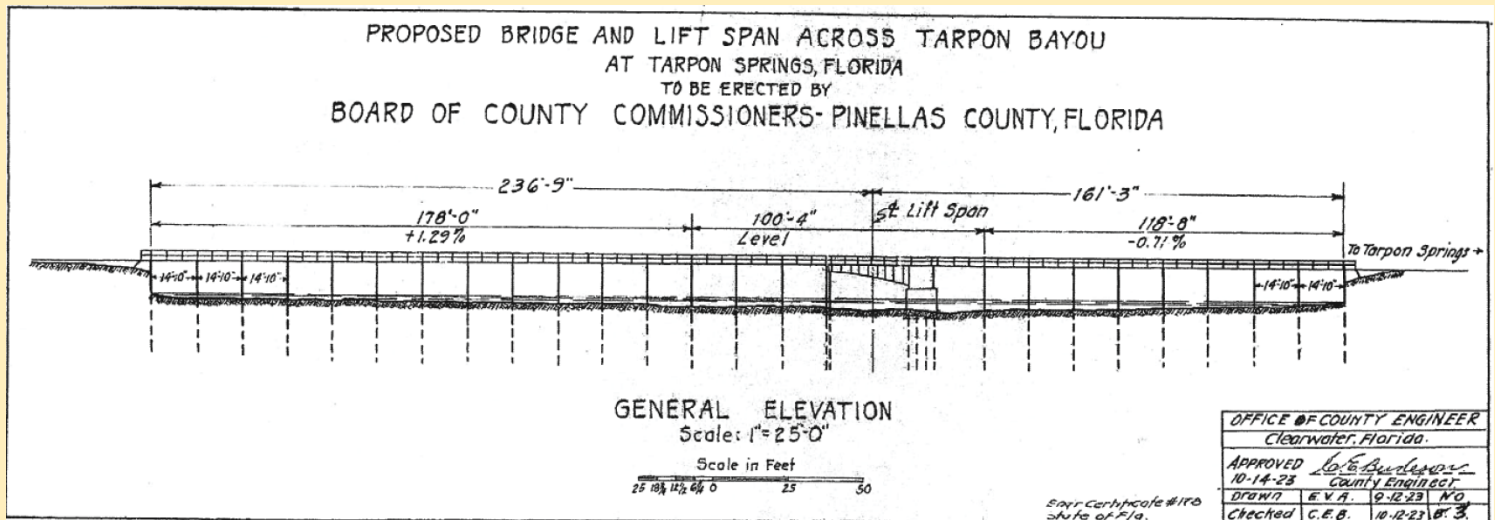

## Possible Mitigation

- Choose Bridge Rail to Preserve Viewshed from Bridge
- Educational Kiosk/Monument in Public Space
  - On or Near Bridge
  - In City Park or Museum
- Incorporate Monument into Second Control House
- Incorporate Portion of Original Bridge into New Bridge



**Possible Minimization/Mitigation**  
**Some Rail Options**





**Example - Treasure Island Bridge**

**Incorporating Part of Existing Bridge into Monument or Educational Display in Park or Public Space**





**Example – Treasure Island**

**Monument Bridge in City Park – Treasure Island**



**Example - South Park Bridge, Seattle, WA**

**Incorporating Part of Existing Bridge into New Bridge**

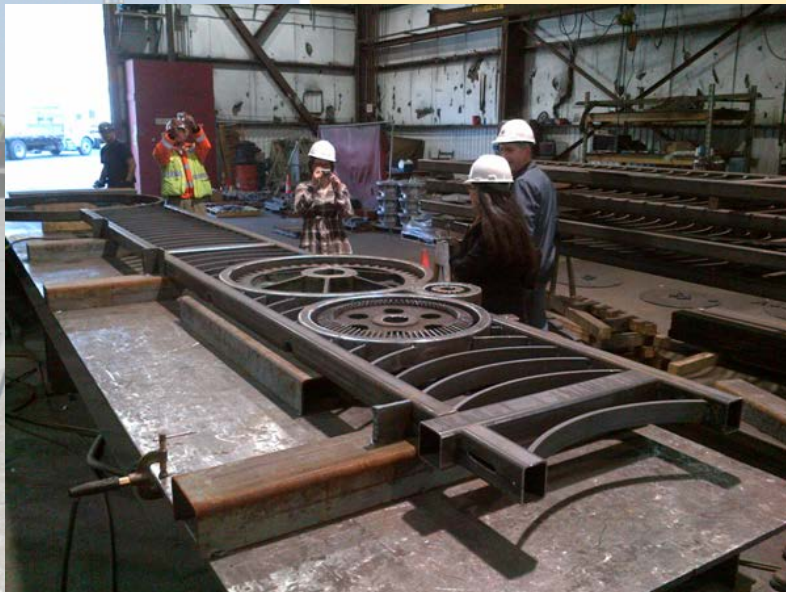

# Pinellas County Minimization/Mitigation Options Public Input

## Public Input/Comments Welcome on Possible Mitigation Options

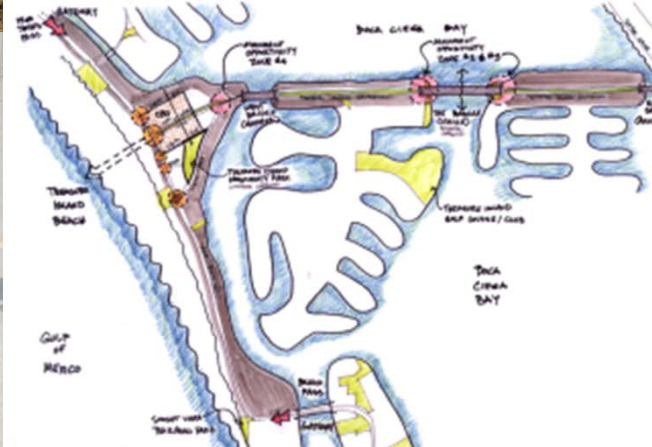

- **SHPO concurred that Movable Bridge Alternative is preferred over Rehabilitation**
- **Project Team has determined that Fixed Bridge Alternatives are not feasible**
- **FHWA concurs that sufficient documentation has been presented to determine that Rehabilitation and Fixed Alternatives are not feasible**

## Fixed Alternatives will Not Be Further Considered as Viable

- USCG determined that 28 feet of vertical clearance “**Does Not Meet the Needs of Navigation**”
- Substantial right-of-way impacts
- Substantial visual impacts
- Not consistent with historic character of community
- Requires two-year detour during construction
- Cost \$14 M - \$15 M (including Right-of-way) compared to New Movable \$15.8 M

# Next Steps in PD&E Process

- **Cultural Resource Committee Meeting**
  - Present summary of SHPO and FHWA Coordination to members
- **County staff select “Recommended Alternative”**
- **Request Concurrence from County BCC**
- **Present Recommended Alternative to MPO Advisory Committees/Board**

- Update Engineering/Environmental Documents
- Present Recommended Alternative at Public Hearing
- Continue SHPO Coordination
  - Develop Mitigation
  - Complete Section 106 documents



# Next Steps in PD&E Process

- Refine Recommended Concept based on Public Hearing Input
- Finalize Engineering/Environmental Documents
- Submit Final Documents to FDOT and FHWA for Approval

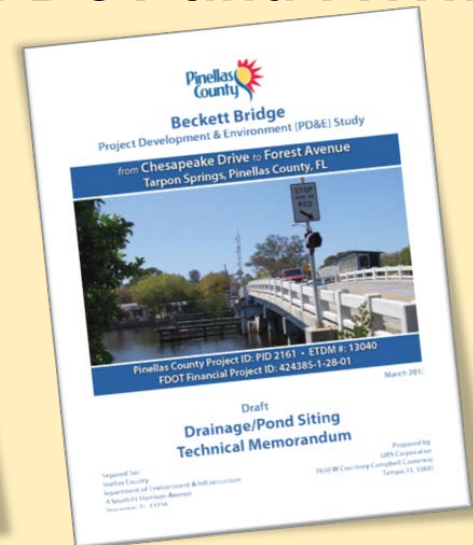



# Questions and Discussion



## Boat Survey of Waterfront Property Owners on Whitcomb Bayou

- 289 Surveyed
- 99 Responded



## Results

- Most Boats 22-26 ft Powerboats
  - No Bridge Opening Required
- 4 Sailboats required  $\geq 28$  ft of Clearance
  - Could not Pass Under Mid-Level Option

- 7.8 feet Vertical Clearance
- 25 feet Horizontal Clearance



Rendering – Not Actual Design



# Detour Routes

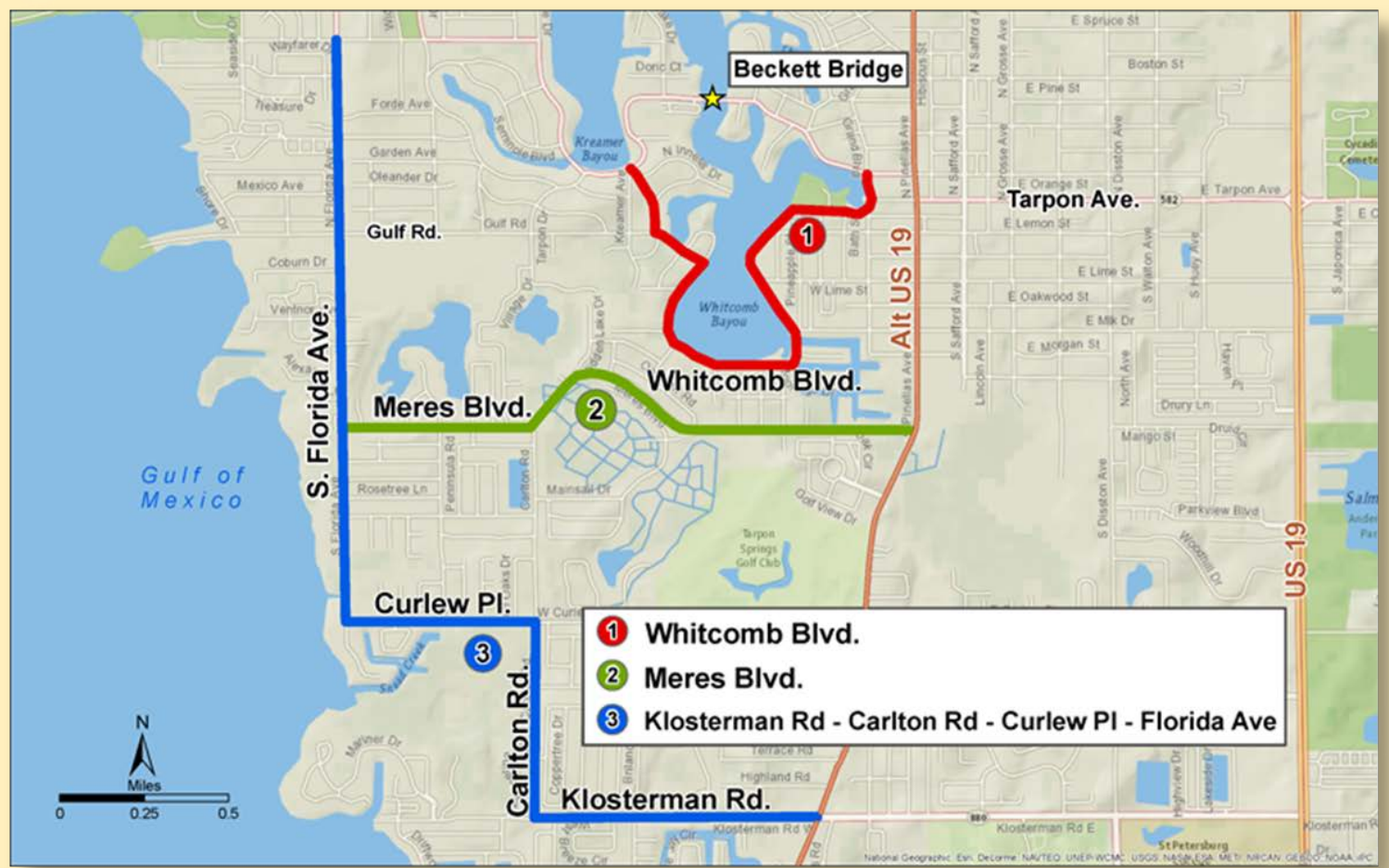



**No Build w/Permanent Removal of Existing Bridge**

**\$0.9 M (Demolition Only)**

**Rehabilitation**

**\$9.5 M**

**Replacement w/Low-Level Movable Bridge**

**\$15.8 M**

**Replacement w/Mid-Level Fixed Bridge**

**\$14 - \$15 M**

**(ROW Costs - \$2.9M Option B, Option A - \$ 4.1 M)**

*Includes Design, Contingency  
& Construction Engineering Inspection*



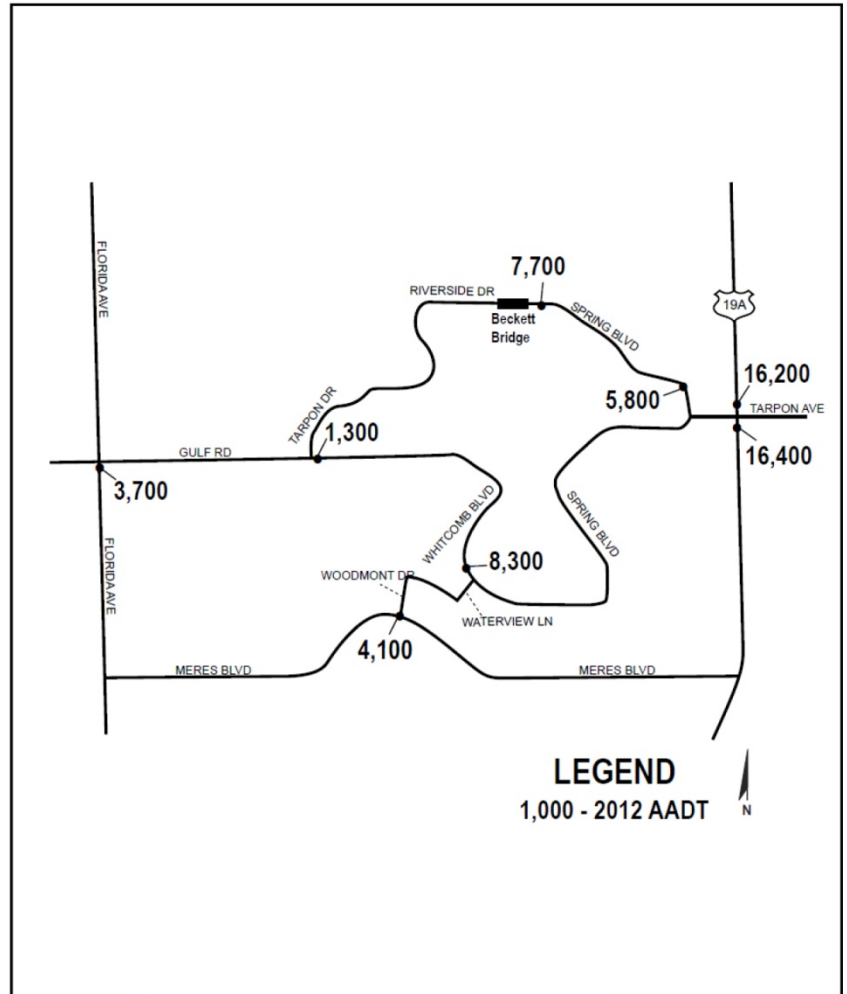

Figure 5-1



Beckett Bridge PD&E Study  
Pinellas County Project ID: PID 2161  
FDOT FPN: 424385-1-28-01 ETDM #: 13040

**Existing (2012) AADT Volumes**



## Bascule Span Engineering

- Current design loading (HL-93) is heavier than existing bridge design load (most likely HS-15)
- Current standards require designing sidewalks for occasional vehicle load (which was not the case for the existing bascule span)
- Bridge rails are currently designed for much higher impact loads and specific “crash tested” geometry
- Minimum width roadway results in higher live loads on the girders, floorbeams and cantilever brackets (at least a 32 percent increase in main girder loading)
- Current design loadings for bridge rails will result in larger loads on the cantilever brackets as will the wider sidewalk

**All main members of the bascule span need to be stronger (larger, heavier steel sections) than the existing**

## Bascule Span Engineering

- New bridge deck will be approximately 37% wider than the existing
- New bascule span will be approximately 62% heavier than the existing
- Counterweight volume is limited by geometry of the existing bascule pier

**Counterweight volume is not sufficient to provide the mass required to balance the span (would require 390 pcf concrete (AASHTO limits counterweight concrete to 315 pcf))**



## **Bascule Span Engineering**

- Existing bascule pier is supported on timber piles of unknown number, length and/or capacity
- Helper piles installed in 1996 are not fully effective in supporting the bascule piers – they were designed to stabilize the pier, not support dead load or live load
- New bascule span will be approximately 62% heavier than the existing

**Existing piers do not have capacity for the added dead and live loads resulting from widening**



# Beckett Bridge PD& E Study

## Alternatives Presentation to:

### City of Tarpon Springs Board of Commissioners



October 2012



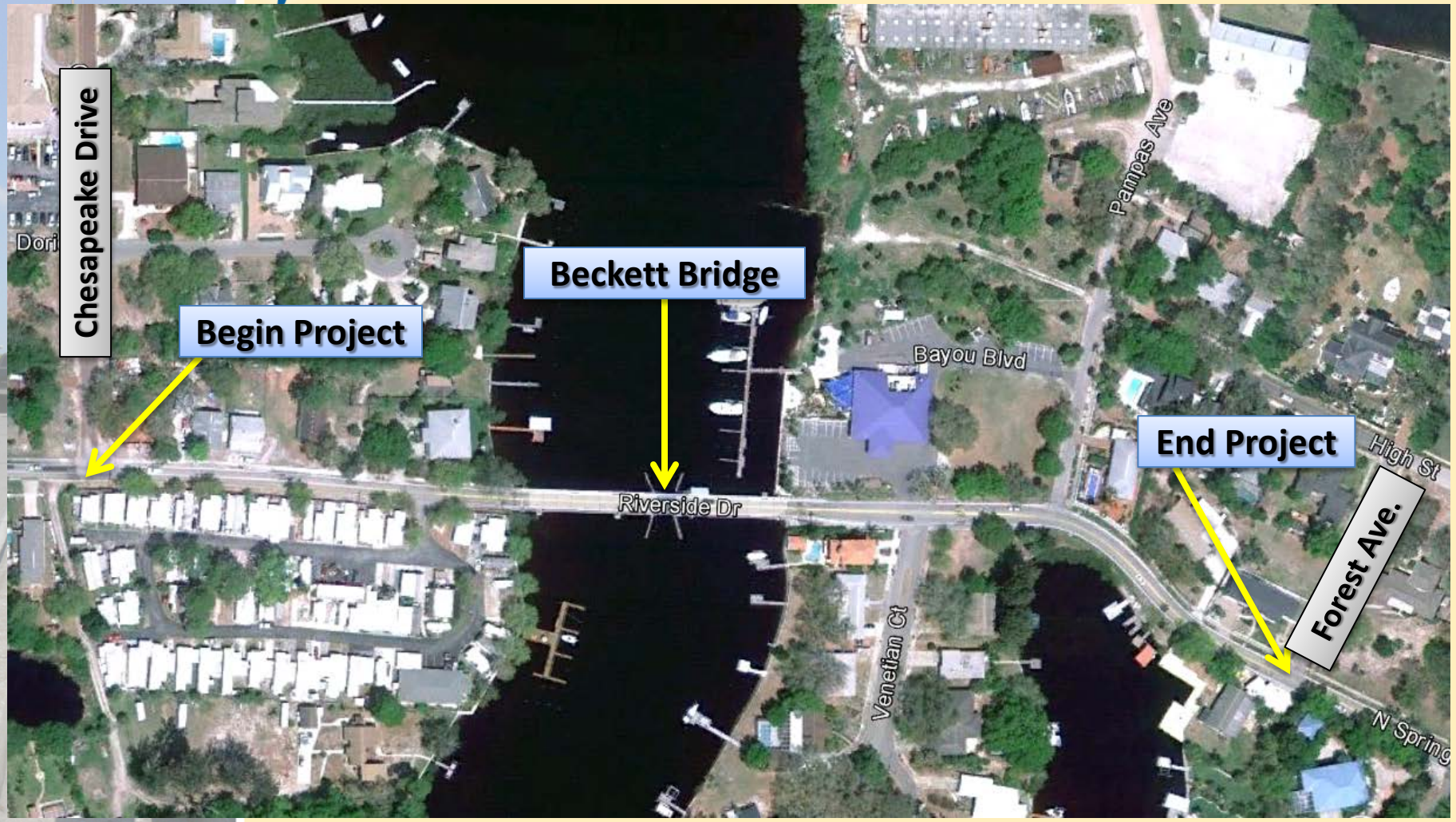



# Existing Bridge

- Determined to be Eligible for listing in the National Register of Historic Places
- Original Timber Construction – 1924
- Rebuilt Concrete Bridge – 1956
  - Major Repairs in 1979, 1998 and 2011
- Sufficiency Rating - 44.9 (Scale of 1 -100)
  - Structural Concerns
  - Functionally Obsolete

- Vertical Clearance – 6 ft
- Horizontal Clearance – 25 ft
- Opens with 2-hr Notice

**Total Bridge  
Openings**

**2009 - 10**

**2010 - 20**

**2011 - 18**



- **Structural Issues**
  - Posted Weight Restrictions (12 tons)
  - Foundations susceptible to settlement
  - Scour Susceptible



- **Functionally Obsolete**
  - **Narrow Sidewalks**
    - Do Not Meet ADA Requirements



- **Narrow Lanes**
  - No Shoulders
  - No bicycle lanes





- **Engineering, Social & Environmental Studies**
- **Community Involvement**
- **Develop and Evaluate Alternatives**
- **Select Preferred Alternative**
- **Obtain FHWA Approval**

- **Community Concerns**
  - Vertical Clearance
  - Noise
  - Construction Impacts
  - Detour/MOT
  - Aesthetics
  - Bicycle/Pedestrian Facilities

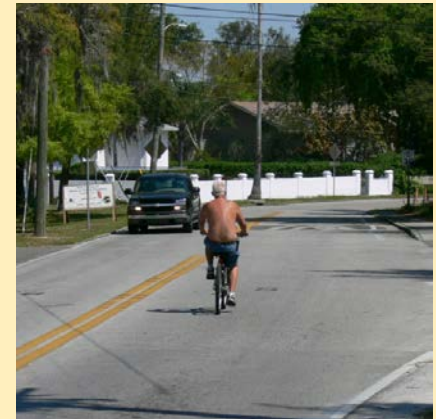
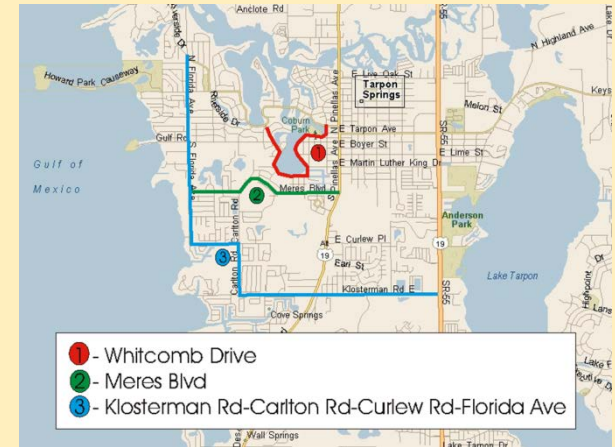

- Project Website
- Coordinate with Local Government
- Meet with Stakeholder Groups
- Alternatives Public Workshop
- Public Hearing





- **No-Build**
- **No-Build with Permanent Removal of Existing Bridge**
- **Rehabilitation**
- **Replacement on Existing Alignment**
  - **Low-Level Movable Bridge**
    - 7.8 ft Vertical Clearance
    - 25 ft Horizontal Clearance
  - **Mid-Level Fixed Bridge**
    - 28 ft Vertical Clearance
    - 25 ft Horizontal Clearance





# No Build Alternative

- Existing Bridge Remains Until No Longer Serviceable (approximately 10 years)
- Routine Maintenance Only
- No Major Improvements



# No Build Alternative – Permanent Removal of Existing Bridge

- Routine Maintenance Only
- Existing Bridge Demolished When No Longer Serviceable
- No Replacement Bridge Constructed

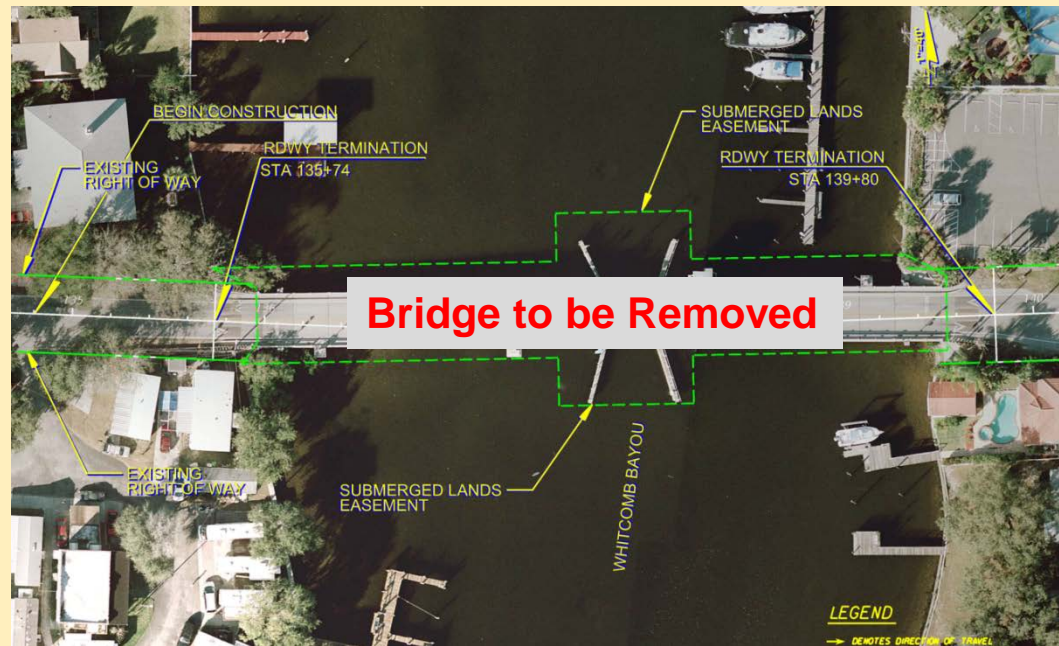

- Extensive Repairs
- Correct Structural Deficiencies
- No Widening
  - No Shoulders
  - Narrow Sidewalks would remain
- No Change in Navigational Clearances
- Extend Service Life 25-30 years



# Replacement Alternatives Constraints

- **Limited Right-of-Way**
  - 50 ft ROW East of Bridge
  - 40 ft ROW West of Bridge



- **Adjacent properties**
- **Driveways**



## Existing Bridge Typical Section

28'-0 1/2" Total Width

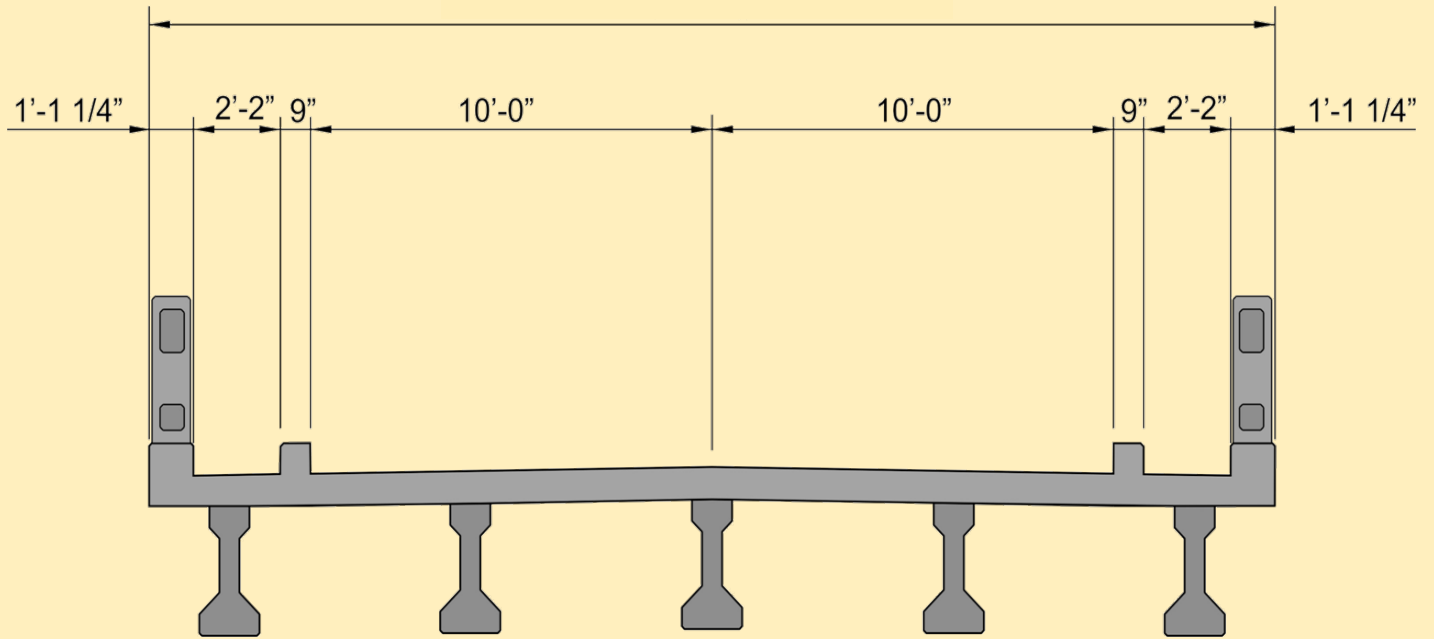

**No Shoulders**

**Narrow Sidewalks**



# Proposed Typical Sections

- **Meet Current Safety Standards**
- **Accommodate Future Trails**
- **Minimize ROW Impacts**
- **Lane Widths**  
10 to 11 feet



## Proposed Bridge Typical Section

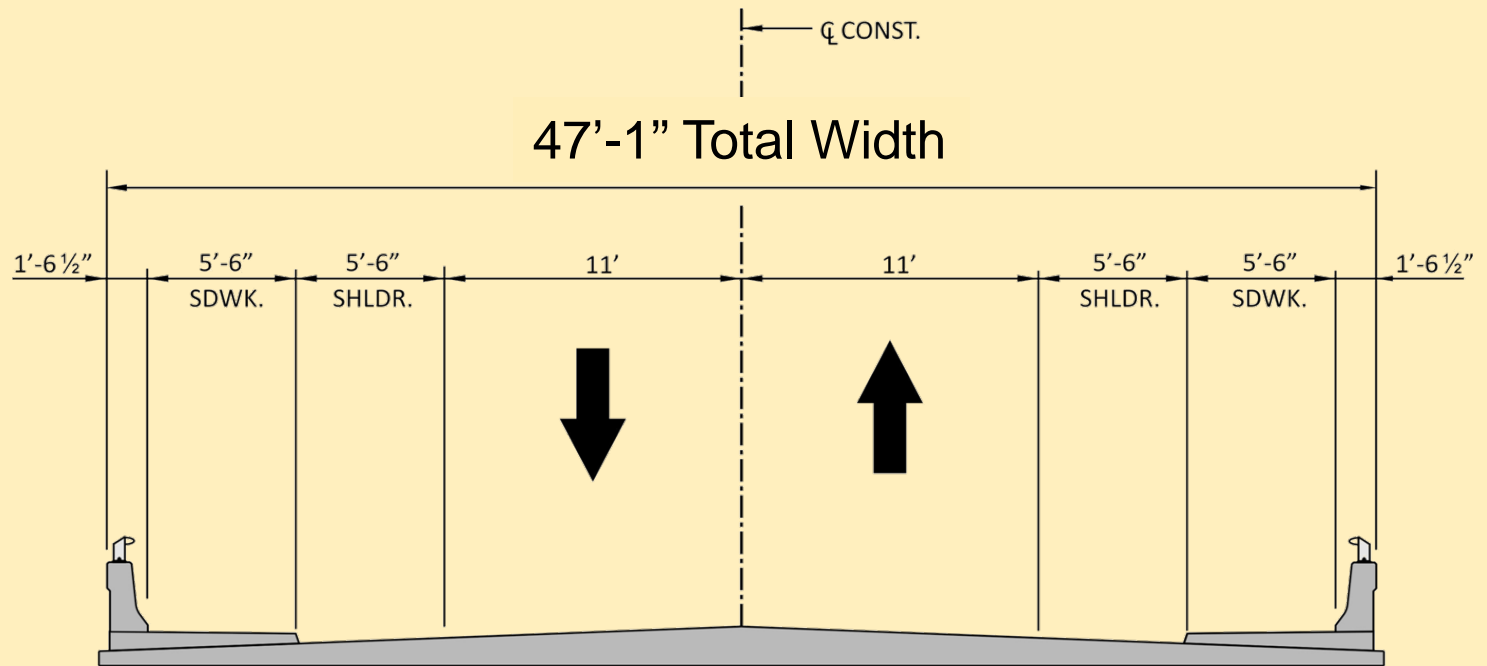

**5'6" Sidewalks and Shoulders – Both Sides**

## Roadway Section – West of Bridge

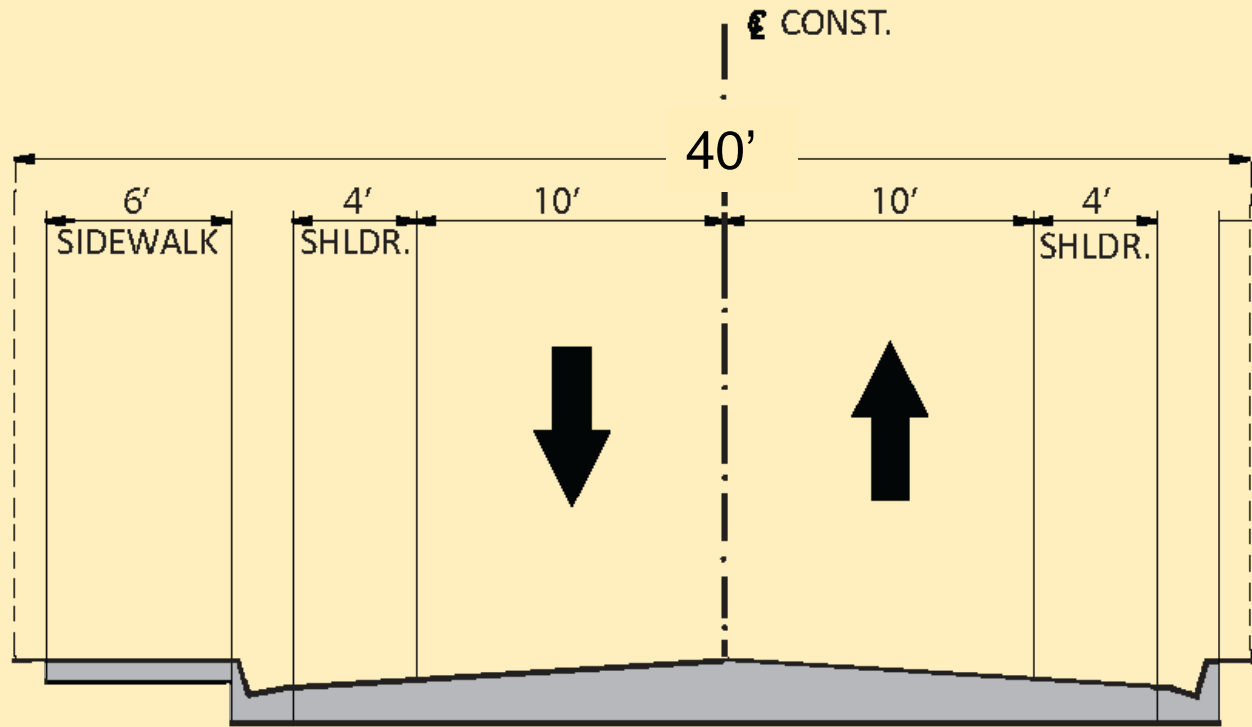

**6 ft Sidewalk - North Side Only**

## Roadway Section – East of Bridge

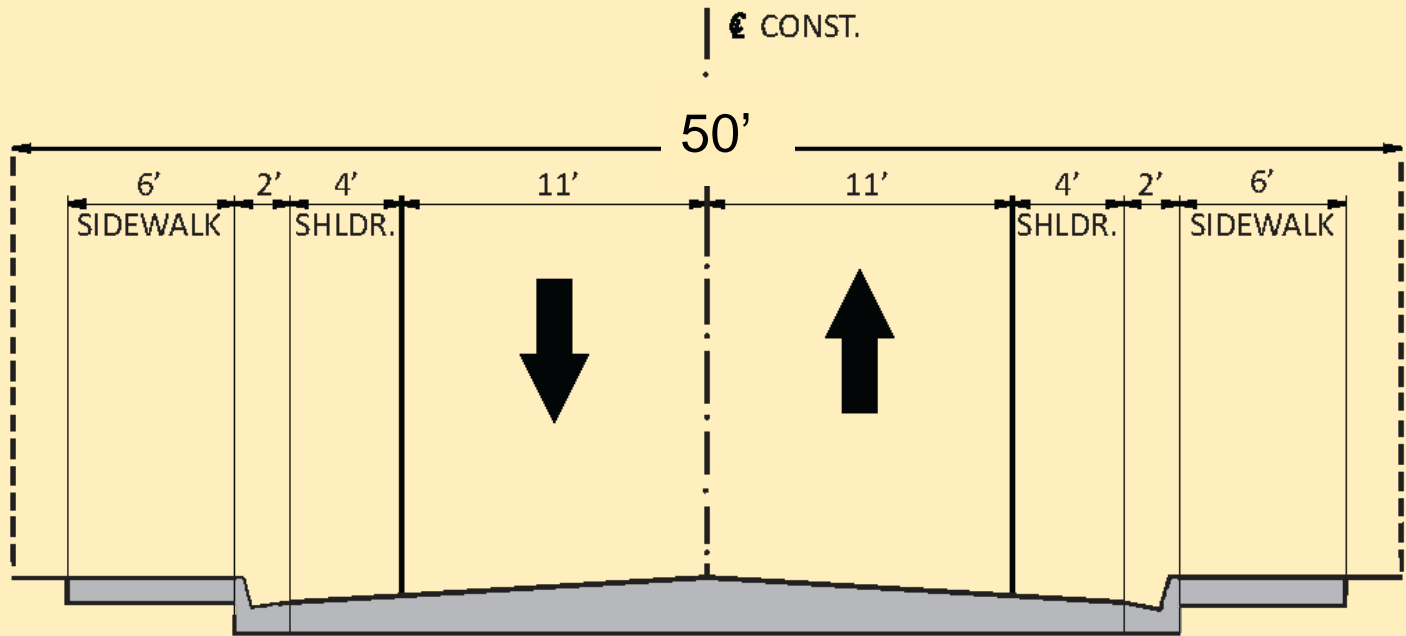

**6 ft Sidewalks - Both Sides**



# Low-Level Movable Bridge

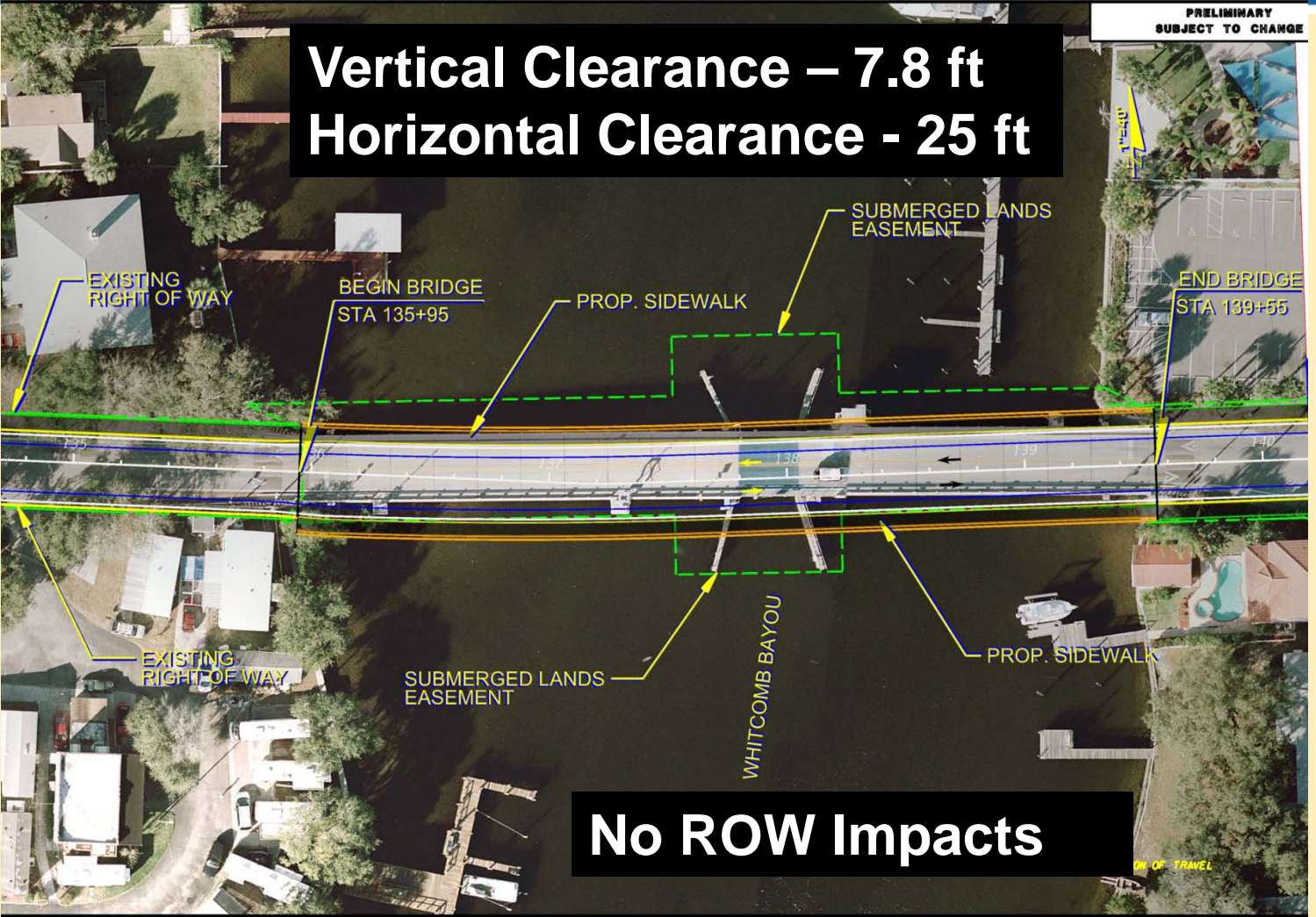



- **Vertical Clearance – 28 feet**
- **Horizontal Clearance – 25 feet**
- **Retaining Wall 1 to 19 feet High**
  - **Blocks Driveway Access/Visual Impacts**
- **ROW impacts**
  - **Single Family Residences North Side, West of Bridge**
  - **Yacht Club Property**





# Mid-Level Fixed Bridge – Option A

## Venetian Court Extension

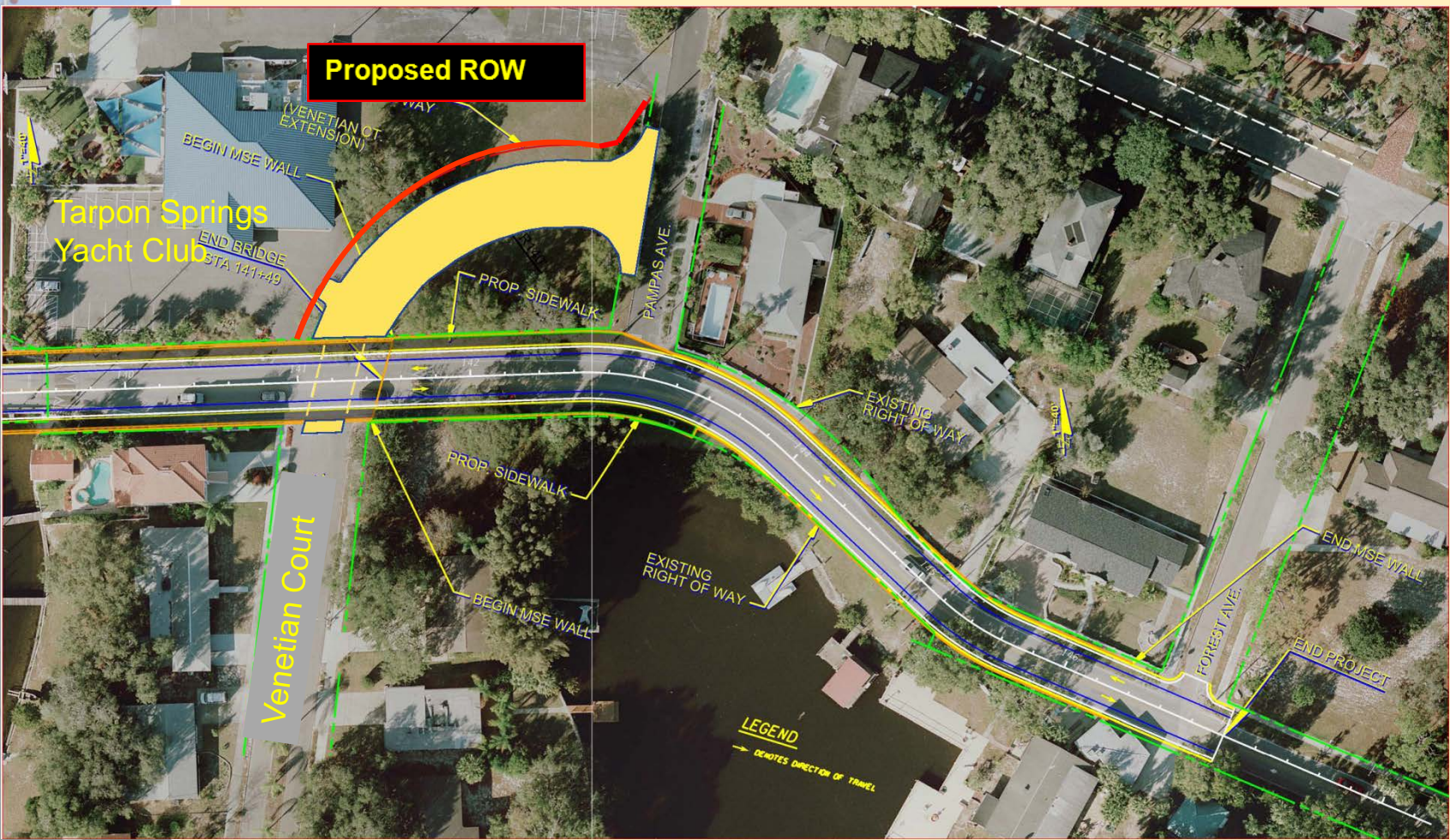





# Mid-Level Fixed Bridge – Option A

## Access Road to Bayshore Mobile Home Park



**Impacts to Residences North of Riverside Drive**



- **Vertical Clearance – 28 feet**
- **Horizontal Clearance – 25 feet**
- **Retaining Wall 1 to 16 feet High**
  - **Blocks Driveway Access/Visual Impacts**
- **ROW impacts**
  - **Single Family Residences North Side,  
West of Bridge**
  - **8 Mobile Homes**
  - **Yacht Club Property**
  - **Vacant Lot East of Bridge, South Side of Roadway**





# Mid-Level Fixed Bridge – Option B

## Venetian Court Extension

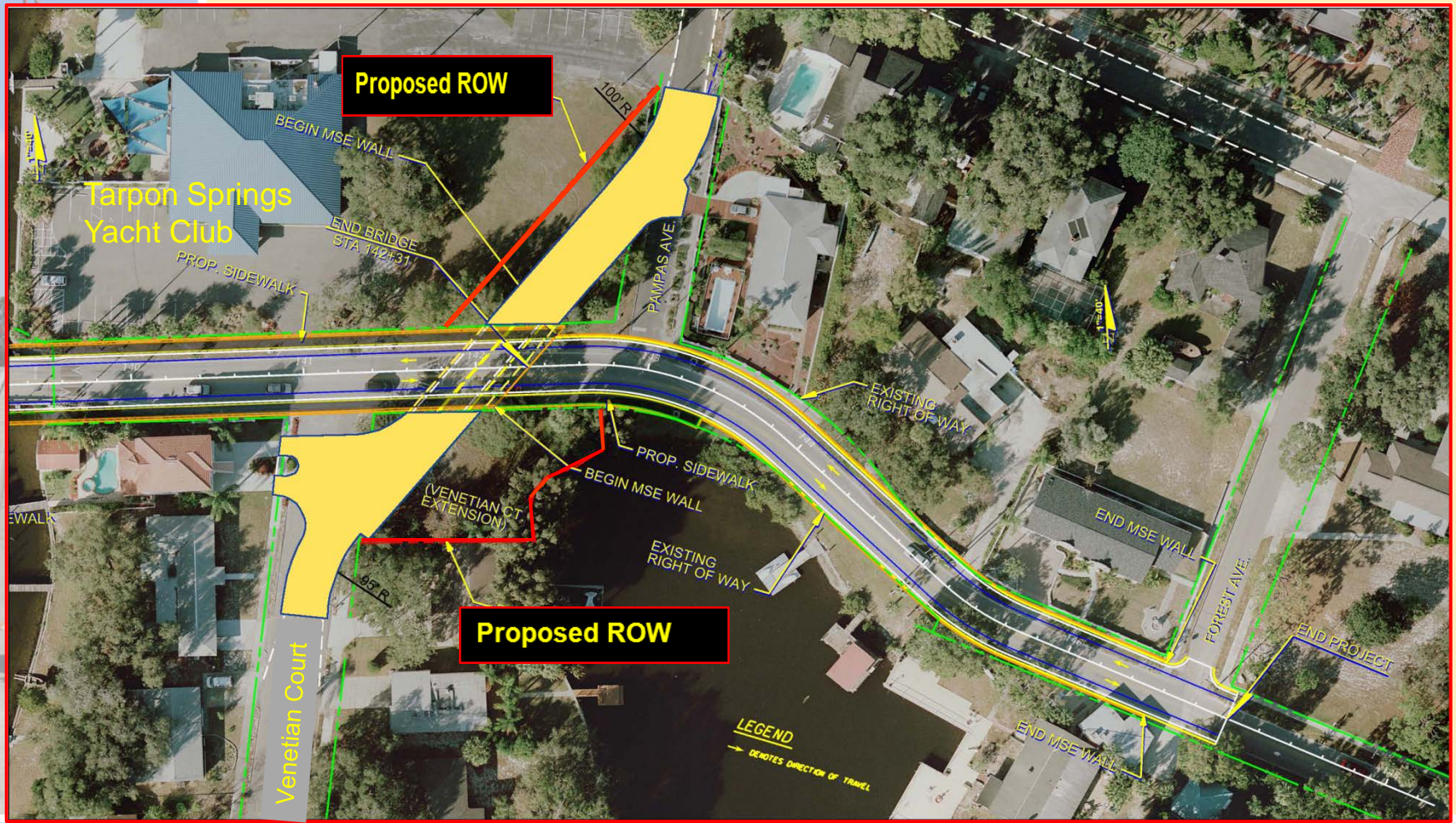



## Boat Survey of Waterfront Property Owners on Whitcomb Bayou

- 289 Surveyed
- 99 Responded



## Results

- Most Boats 22-26 ft Powerboats
  - No Bridge Opening Required
- 4 Sailboats required  $\geq 28$  ft of Clearance
  - Could not Pass Under Mid-Level Option

## Similar for All Build Alternatives

- **Wetlands**
  - 0.02 acre – Low-Level
  - 0.03 acre – Mid-Level
  - Wildlife - Minimal
- **Noise - Minimal**
- **Visual – Minimal to High**
- **Historic Structures**
  - Removal of NRHP Eligible Bridge Requires MOA/Mitigation





# PD&E Schedule

Activity	2012				2013				
	Jan - Mar	Apr - Jun	Jul - Sep	Oct - Dec	Jan - Mar	Apr - Jun	Jul - Aug	Sep - Oct	Nov - Dec
Study Begins	★								
Data Collection	█								
Develop/Evaluate Alternatives	█								
Local Government Coordination			█						
Alternatives Workshop					★				
Select Preferred Alternative					█				
Public Hearing							★		
Final Reports/Agency Coordination					█				
Approval by the Federal Highway Administration									★



**Questions?**





MINUTES  
BOARD OF COMMISSIONERS  
CITY OF TARPON SPRINGS  
REGULAR SESSION – NOVEMBER 20, 2012

THE BOARD OF COMMISSIONERS OF THE CITY OF TARPON SPRINGS, FLORIDA, MET IN REGULAR SESSION IN THE CITY HALL AUDITORIUM/COMMISSION CHAMBERS, 324 EAST PINE STREET, ON TUESDAY, NOVEMBER 20, 2012 AT 6:30 P.M. WITH THE FOLLOWING PRESENT:

DAVID O. ARCHIE	MAYOR
CHRIS ALAHOUZOS	VICE MAYOR
SUSAN SLATTERY	COMMISSIONER
JEFF LARSEN	COMMISSIONER
TOWNSEND TARAPANI	COMMISSIONER

ALSO PRESENT:	MARK LECOURIS	CITY MANAGER
	IRENE S. JACOBS	CITY CLERK & COLLECTOR
	JAMES YACAVONE III	CITY ATTORNEY

CALL TO ORDER:

Mayor Archie called the meeting to order at 6:30 p.m.

ROLL CALL:

City Clerk Jacobs called the roll.

INVOCATION:

Reverend Raymond Stallworth, Mt. Moriah AME Church, gave the invocation.

PLEDGE OF ALLEGIANCE TO THE FLAG

Mayor Archie led the Pledge of Allegiance to the Flag.

PUBLIC COMMENTS:

The Mayor asked for public comments and there were none.

PROCLAMATIONS:

1. FARM CITY WEEK:

Mayor Archie proclaimed November 16-22, 2012 as Farm City Week. No one was at the meeting to accept the proclamation; therefore, the City Clerk would mail.

Mayor Archie asked for Board and public comments and there were none.

PRESENTATION:

2. CHAMBER OF COMMERCE BEAUTIFICATION AWARD:

Sue Thomas, President Tarpon Springs Chamber of Commerce, 111 East Tarpon Avenue, presented, Attorney Michael Kouskoutis, with the Chamber's Beautification Award. Mr. Kouskoutis thanked the Chamber for the recognition .

Mayor Archie thanked Mr. Kouskoutis for all he does for the City.

Mayor Archie asked for public comments and there were none.

3. BECKETT BRIDGE REHABILITATION, REPLACEMENT: ANN VENABLES,  
E.C. DRIVER & ASSOCIATES

Ann Venables, Project Manager gave a power point presentation highlighting the Beckett Bridge PD & E Study Alternatives; History of the Bridge; project needs; PD & E Process; Community Concerns; and various bridge options. Additionally she stated that the bridge was determined to be eligible for listing in the National Register of Historic Places.

The Board thanked all and Pinellas County for making the presentation, and made known residents' concerns of the future bridge. Mayor Archie asked if money was the factor for the design of the bridge, when and where the next public meeting was. Ms. Venables replied that money was only one part of the factor and not the deciding one of the design, and the meeting would be held January 23, 2013 at the Yacht Club and would forward information for the City to post on their website. Commissioner Tarapani inquired if the County discussed any other types of bridge options like swing, and what the preference was based on the options. Mr. Driver said that yes, all options were looked at, and stated his preference, but did not have a preference on a high or low level. Commissioner Tarapani did not see eliminating a fixed bridge but was in favor of the option with the least impact to the city, and would like the residents affected in this matter to be treated with fairness. Commissioner Larsen asked about the bridge on the register, the sufficiency rating, and if the long term vision was also an aspect of the project. Mrs. Venables said that the bridge was unique as it was one of the oldest bridges of that style and then explained the formula on inspection rating and said that the primary thing driving the low rating was safety due to the narrow widths and no shoulders. Vice Mayor Alahouzos wanted to know if property owners were contacted, if during the construction or rehabilitation if the channel would be open and if dredging occur. (Continued)

3. BECKETT BRIDGE REHABILITATION, REPLACEMENT: ANN VENABLES,  
E.C. DRIVER & ASSOCIATES

---

Mrs. Venables responded that property owners were not contacted yet that at this time they were reviewing options, the channel would be shut for a brief time and that they would not be dredging.

PUBLIC COMMENTS:

Bill Vinson, 144 Spring Boulevard, former Commissioner, shared with the Board what Riparian Rights are according to the Florida Statute 253.141. Mr. Vinson felt resident issues were not addressed in presentation nor were the importance of these rights made clear.

Mayor Archie encouraged residents to attend this meeting because the Board of Commissioner's voice was no more powerful than the resident's voice on this County project.

4. CYCADIA CEMETERY SECURITY IMPROVEMENTS

Paul Smith, Public Services Director, presented a power point on Cycadia Cemetery security improvements, and gave background that this has come about due to vandalism throughout the years.

The Board thanked Mr. Smith for bringing forward. Mayor Archie felt this was much needed and questioned the gate. Mr. Smith said that anyone already in the cemetery would be able to exit. Vice Mayor Alahouzos knew that the fence was something that was dear to the late Mr. Powell, Cycadia Cemetery Chairman, and former Commissioner. Additionally, Vice Mayor Alahouzos would like to see landscaping placed along the fencing. Commissioner Tarapani asked why the fence was not on top of existing cement wall and if lighted columns will go between areas of fencing, and Mr. Smith said placing fencing on wall was explored and it was not strong enough and someone could climb and go over. As far as the columns, it would be explored and if too expensive can always do at a later time.

CONSENT AGENDA:

5. SATISFACTION AND RELEASE OF LIENS:

Kendra A. Phillips	Mortgage Lien	MR 1223
Edward Bodema		
Blake T. Lanston	Utility Lien	34327-271102281
George Paitakis/ Mary A. Paitakis	Utility Lien	18913-271305052
Raymond F. Sieper	Utility Lien	46251-271203474
George M. Geiser, Jr.	Utility Lien	39423-271808986
Thomas D'Arangelo	Code Enforcement	12-80000107
Cristos Stefos	Code Enforcement	09-20000090
Timothy W. Hobgood	Certificate of Indebtedness (Abatement for lot mowing)	10-80000230

6. ATTORNYE'S FEES:

a. Frazer Hubbard Brandt Trask Yacavone Metz & Diagneault, LLP: Invoice # 40143.

7. SPECIAL EVENTS:

a. There's Snow Place Like Tarpon Avenue; Tarpon Springs Chamber of Commerce and City of Tarpon Springs, December 7, 2012.

8. APPROVE REVISED POSITION DESCRIPTION FOR TRAFFIC MAINTENANCE WORKER

9. RENEW RFQ NO. 080083: SURVEY SERVICES CONTINUING CONTRACT

10. INCREASE FILE NO. 120052-N-JJ:WATER & WASTEWATER REVENUE SUFFICIENCY

ADDENDUM 1. REJECT ALL PROPOSALS SUBMITTED FOR PROPOSAL NO. 120125-P-CM, INSURANCE PROGRAMS: LIFE AND LONG TERM DISABILITY

Mayor Archie asked for Board and public comments and there were none.

MOTION: VICE MAYOR ALAHOUZOS  
SECOND: COMMISSIONER SLATTERY

To approve consent agenda items 5, 6A ,7A,8,9,10, and addendum 1.

Vote on Motion – Upon roll call vote the motion carried unanimously as follows:

Commissioner Tarapani	Absent did not vote*
Commissioner Larsen	Yes
Commissioner Slattery	Yes
Vice Mayor Alahouzos	Yes
Mayor Archie	Yes

\* Temporarily left the meeting room.

SPECIAL CONSENT AGENDA:

11. AWARD BID NO. 12019-B-JJ: TRAVELING BRIDGE FILTER REHABILITATION

Paul Smith said this was a major project for the waste water treatment facility and asked for approval.

Commissioner Larsen was concerned only one bid and asked for comments by Paul Smith received from pre-bid process. Mr. Smith explained to save city money on tax, they pre-purchased materials and some bidders will not bid when that happens because it takes away some mark up on material from potential bidders. Vice Mayor Alahouzos asked if there would be a project manager to oversee since this was a big project and Mr. Smith replied that would be Ray Page.

Mayor Archie asked for public comments and there were none.

MOTION: VICE MAYOR ALAHOUZOS  
SECOND: COMMISSIONER SLATTERY

To award bid No. 12019-B-JJ, traveling bridge Filter rehabilitation to Wharton-Smith, Inc., the only respondent, in an amount not-to-exceed \$ 685,710 which includes the acceptance of additive alternate 1, variable frequency drives for the backwash pumps.

Vote on Motion – Upon roll call vote the motion carried unanimously as follows:

Commissioner Tarapani	Yes
Commissioner Larsen	Yes
Commissioner Slattery	Yes
Vice Mayor Alahouzos	Yes
Mayor Archie	Yes

(Continued)

12. AUTHORIZE THE PURCHASE OF VARIOUS VEHICLES & EQUIPMENT THROUGH  
FLORIDA SHERIFF'S ASSOCIATION CONTRACT NO. 12-10-0905

---

City Manager said both agenda items 12 and 13 were already approved in the budget but awaiting for bids to get the best deals.

Mayor Archie asked for public comments and there were none.

MOTION: VICE MAYOR ALAHOUZOS  
SECOND: COMMISSIONER LARSEN

Authorize the purchase of various vehicles & equipment through Florida Sheriff's Association Contract No. 12-10-0905 for a total aggregate not to exceed amount of \$130,045.00 for Water, Sewer, and Lift Stations.

Vote on Motion – Upon roll call vote the motion carried unanimously as follows:

Commissioner Tarapani	Yes
Commissioner Larsen	Yes
Commissioner Slattery	Yes
Vice Mayor Alahouzos	Yes
Mayor Archie	Yes

(Continued)

13. AUTHORIZE THE PURCHASE OF VARIOUS VEHICLES & EQUIPMENT THROUGH  
FLRODA SHERIFF'S ASSOCIATION CONTRACT NO. 12-20-0995

Commissioner Tarapani questioned if purchasing seven cars were out of the ordinary and City Manager explained that they were from different department were vehicles were going to cost more in maintenance then replacing.

Mayor Archie asked for public comments and there were none.

MOTION: COMMISSIONER TARAPANI  
SECOND: VICE MAYOR ALAHOUZOS/COMMISSIONER SLATTERY

Authorize the purchase of various vehicles & equipment through Florida Sheriff's Association Contract No. 12-20-0905 for a total aggregate not to exceed amount of \$ 385,426.99 the Fire, Police, Sewer Collection, Meter Readers, meter Repair, Water Supply and Stormwater.

Vote on Motion – Upon roll call vote the motion carried unanimously as follows:

Commissioner Tarapani	Yes
Commissioner Larsen	Yes
Commissioner Slattery	Yes
Vice Mayor Alahouzos	Yes
Mayor Archie	Yes

ORDINANCES AND RESOLUTIONS:

14. RESOLUTION 2012-47: FINAL BUDGET RESOLUTION FOR FISCAL YEAR 2012

City Attorney Yacavone read the following Resolution by title only:

A RESOLUTION OF THE BOARD OF COMMISSIONERS OF THE CITY OF TARPON SPRINGS, FLORIDA, AMENDING THE BUDGET FOR FISCAL YEAR 2011-12.

Arie Walker, Finance Director said that this was required by state statute to bring final budget sixty days prior to the end of the year.

Mayor Archie asked for Board or Public comments and there were none.

MOTION: VICE MAYOR ALAHOUZOS  
SECOND: COMMISSIONER SLATTERY/COMMISSIONER LARSEN

That resolution 2012-47 be adopted  
as presented.

Vote on Motion – Upon roll call vote the motion carried unanimously as follows:

Commissioner Tarapani	Absent did not vote
Commissioner Larsen	Yes
Commissioner Slattery	Yes
Vice Mayor Alahouzos	Yes
Mayor Archie	Yes

(Continued)



ORDINANCES AND RESOLUTIONS (Continued):

15. RESOLUTION 2012-48: FRAUD AND WHISTLEBLOWER POLICY

City Attorney Yacavone read the following Resolution by title only:

A RESOLUTION OF THE BOARD OF COMMISSIONERS OF THE CITY OF TARPON SPRINGS ADOPTING A CODE OF ETHICS POLICY AND A FRAUD, WASTE, ABUSE, AND WHISLEBLOWER PROTECTION POLICY; AND PROVIDING FOR AN EFFECTIVE DATE.

City Manager LeCouris said that this was brought back only in policy form as requested by the auditors request.

Mayor Archie asked for Board and Public comments and there were none.

MOTION: COMMISSIONER SLATTERY  
SECOND: VICE MAYOR ALAHOUZOS

That Resolution 2012-48 be adopted  
as presented .

Vote on Motion – Upon roll call vote the motion carried unanimously as follows:

Commissioner Tarapani	Yes
Commissioner Larsen	Yes
Commissioner Slattery	Yes
Vice Mayor Alahouzos	Yes
Mayor Archie	Yes

STAFF COMMENTS:

CYCADIA CEMETERY

City Manager LeCouris said when fence project was completed to honor the history and family a plaque would be presented to the Powell family.

THANKSGIVING WISHES:

Acting Police Chief Young, City Attorney Yacavone, City Clerk Jacobs, and the Board wished all a safe and Happy Thanksgiving.

BOARD COMMENTS:

CHRISTMAS DECORATIONS:

Commissioner Alahouzos told the City Manager that Christmas decorations look good; however, the Sponge Docks needed added decorations.

CHRISTMAS TREE LOT:

Commissioner Slattery announced that the opening of the Boys and Girls Club Christmas Tree lot would be open around Thanksgiving.

Commissioner Tarapani thanked Commissioner Slattery for her efforts with the Boys and Girls Club.

ADJOURNMENT:

The meeting adjourned at: 7:46 P.M.

---

DAVID O. ARCHIE  
MAYOR

ATTEST:

---

IRENE S. JACOBS, CMC  
CITY CLERK & COLLECTOR

CITY CLERK'S NOTE: This meeting has been recorded in its entirety and the recordings are kept on file in the City Clerk's Office for the required retention period.



# *City of Tarpon Springs, Florida*

**Board of Commissioners**  
**324 East Pine Street**  
**Post Office Box 5004**  
**Tarpon Springs, Florida 34688-5004**  
**(727) 938-3711**  
**Fax: (727) 937-8199**  
[www.ctsfl.us](http://www.ctsfl.us)

## **REGULAR SESSION AGENDA** **TUESDAY, NOVEMBER 20, 2012** **6:30 P.M.**

CALL TO ORDER  
ROLL CALL  
INVOCATION  
PLEDGE OF ALLEGIANCE  
PUBLIC COMMENTS

### PROCLAMATION:

1. FARM CITY WEEK

### PRESENTATIONS:

2. CHAMBER BEAUTIFICATION AWARD
3. BECKETT BRIDGE REHABILITATION, REPLACEMENT: ANN VENABLES, E. C. DRIVER & ASSOCIATES
4. CYCADIA CEMETERY SECURITY IMPROVEMENTS

### CONSENT AGENDA:

5. SATISFACTION AND RELEASE OF LIENS
6. ATTORNEY'S FEES:
  - A. FRAZER HUBBARD BRANDT TRASK YACAVONE METZ & DIAGNEAULT, LLP:  
INVOICE # 40143
7. SPECIAL EVENTS:
  - A. THERE'S SNOW PLACE LIKE TARPON AVENUE; TARPON SPRINGS CHAMBER OF COMMERCE AND CITY OF TARPON SPRINGS, DECEMBER 7, 2012
8. APPROVE REVISED POSITION DESCRIPTION FOR TRAFFIC MAINTENANCE WORKER
9. RENEW RFQ NO. 080083: SURVEY SERVICES CONTINUING CONTRACT
10. INCREASE FILE NO. 120052-N-JJ: WATER & WASTEWATER REVENUE SUFFICIENCY ANALYSIS UPDATE AND BOND REPORT

### SPECIAL CONSENT AGENDA:

11. AWARD BID NO. 120119-B-JJ: TRAVELING BRIDGE FILTER REHABILITATION
12. AUTHORIZE THE PURCHASE OF VARIOUS VEHICLES & EQUIPMENT THROUGH FLORIDA SHERIFF'S ASSOCIATION CONTRACT NO. 12-10-0905
13. AUTHORIZE THE PURCHASE OF VARIOUS VEHICLES & EQUIPMENT THROUGH FLORIDA SHERIFF'S ASSOCIATION CONTRACT NO. 12-20-0905

### ORDINANCES AND RESOLUTIONS:

14. RESOLUTION 2012-47: FINAL BUDGET RESOLUTION FOR FISCAL YEAR 2012
15. RESOLUTION 2012-48: ETHICS, FRAUD AND WHISTLEBLOWER POLICY

BOARD AND STAFF COMMENTS:  
ADJOURNMENT