

# US 41 (SR 45)

From Kracker Avenue to South of SR 676 (Causeway Boulevard)  
Project Development and Environment (PD&E) Study



## Final Design Traffic Technical Memorandum



January 2017

# **US 41 (SR 45)**

**From Kracker Avenue to South of SR 676 (Causeway Boulevard)**

Project Development & Environment (PD&E) Study

## ***Final Design Traffic Technical Memorandum***

Work Program Item Segment No. 430056-1

ETDM Project No. 5180

Hillsborough County

*Prepared for:*

Florida Department of Transportation

District Seven



Lilliam Escalera

FDOT Project Manager

*Prepared by:*

American Consulting Engineers of Florida, LLC

2818 Cypress Ridge Boulevard, Suite 200

Wesley Chapel, FL 33544

**January 2017**

## CERTIFICATION OF PROJECTED TRAFFIC VOLUMES

PROJECT: US 41 PD&E Study from Kracker Avenue to South of SR 676 (Causeway Boulevard) Design Traffic Technical Memorandum

WPI Segment No: 430056-1

COUNTY: Hillsborough County

CLIENT: Florida Department of Transportation, District 7

This memorandum includes a summary of data collection efforts, traffic demand projection calculations, and capacity/level of service analysis for the US 41 Design Traffic Technical Memorandum.

"I have followed the Project Traffic Forecasting Procedures adopted by the Florida Department of Transportation to arrive at the project traffic volumes. I have found these to be consistent with the historical traffic data and other available information."

SIGNATURE: \_\_\_\_\_

NAME: Akram M. Hussein, PE / PTOE  
Florida P.E. # 58069  
American Consulting Engineers of Florida, LLC

DATE: December 2016

## EXECUTIVE SUMMARY

---

The Florida Department of Transportation (FDOT) conducted a Project Development and Environment (PD&E) Study to evaluate alternative improvements for US 41 (SR 45) from Kracker Avenue (milepoint 15.784) to south of SR 676 (Causeway Boulevard – milepoint 22.791) in Hillsborough County (**Figure 1-1**), a distance of approximately 7.0 miles. Study objectives included: determine proposed typical sections and develop preliminary conceptual design plans for proposed improvements, while minimizing impacts to the environment; consider agency and public comments; and ensure project compliance with all applicable federal and state laws. Improvement alternatives were identified which will improve safety and satisfy future transportation demand. A *State Environmental Impact Report* (SEIR) was prepared for this study and approved on January 12, 2017.

This *Design Traffic Technical Memorandum* was prepared for the proposed project. Analysis was performed as a part of this study for the existing year (2013) and the future years – opening year (2020), interim year (2030) and design year (2040) with the existing and the future traffic volumes.

The operational analysis was performed for existing conditions with the existing lane geometry and 2013 traffic. The acceptable level of service (LOS) standard for the study corridor of US 41 in the urbanized area within the project limits is ‘LOS D’ per FDOT based on the “Planning Boundaries for LOS Standards Hillsborough County”. The existing intersection analysis showed that most of the study intersections operate at an acceptable level of service LOS D or better during both AM and PM peak periods with the exception of the intersections of US 41 at Florence Street, Nundy Avenue, CR 676A (Madison Avenue/Pendola Point Road) and Hartford Street. The existing roadway segment analysis showed that the segment of US 41 between Palm Avenue and Gibsonton Drive/Alice Avenue does not operate at an acceptable LOS in the northbound direction during the AM peak period. And the segment of US 41 between Port Sutton Road and CR 676A (Madison Avenue/Pendola Point Road) in the southbound direction does not operate at an acceptable LOS during the PM peak period.

Operational analyses of future conditions for years 2020, 2030 and 2040 were conducted for both the no-build and the build conditions. The same set of traffic projections and volumes were used for both conditions. The no-build condition considered the existing lane geometry. The analysis showed that the intersections and the roadway segments deteriorated during the future years under the no-build conditions.

The operational analysis for build conditions was conducted to assess the impact of widening US 41 in improving capacity and traffic operation along the study corridor and also, identify required turn lanes at intersections to operate at an acceptable level of service. The build condition considered widening US 41 to six lanes within the project limits. The build analysis performed in this study showed that widening of US 41 to six lanes with intersection turn lane improvements from Kracker Avenue to south of SR 676 (Causeway Boulevard) would result in improved traffic operation and reduced delay by 2040 along the US 41 roadway segments within the project limits. Pedestrian

crosswalks, pedestrian ramps and pedestrian signals will be provided per FDOT standards as a part of the design for the widening project. Also, crosswalks will be provided at all unsignalized intersections per FDOT District Seven standards. Pedestrian and bicycle safety will be enhanced by providing sidewalks and bike lanes along the entire project corridor.

## Table of Contents

---

SECTION 1	INTRODUCTION .....	1-1
1.1	PD&E Study Purpose .....	1-1
1.2	Project Description.....	1-1
1.3	Existing Facility and Planned Improvements .....	1-1
1.4	Project Purpose and Need .....	1-5
1.5	Report Purpose .....	1-9
SECTION 2	EXISTING CONDITIONS & TRAFFIC.....	2-1
2.1	Roadway and Intersection Characteristics.....	2-1
2.2	Traffic Characteristics.....	2-1
2.3	Traffic Parameters.....	2-4
2.4	Development of Existing Year (2013) Design Hour Traffic Volumes.....	2-5
2.5	Existing Year (2013) Intersection Level of Service Analysis .....	2-7
2.6	Existing Year (2013) Roadway Segment Analysis.....	2-9
2.7	Crash Analysis.....	2-10
SECTION 3	FUTURE TRAFFIC PROJECTIONS .....	3-1
3.1	Travel Demand Model.....	3-1
3.2	Development of Future Year Annual Average Daily Traffic (AADT) and Design Hour Traffic Volumes .....	3-2
SECTION 4	FUTURE OPERATIONAL ANALYSIS.....	4-1
4.1	Potential for Signalization at the Unsignalized Study Intersections along US 41 .....	4-2
4.2	Design Year (2040) No-Build Level of Service Analysis .....	4-4
4.3	Design Year (2040) Build Level of Service Analysis .....	4-5
4.4	Interim Year (2030) No-Build Level of Service Analysis .....	4-9
4.5	Interim Year (2030) Build Level of Service Analysis .....	4-12
4.6	Opening Year (2020) No-Build Level of Service Analysis .....	4-13
4.7	Opening Year (2020) Build Level of Service Analysis .....	4-15
4.8	Intersection Turn Lane Storage Lengths .....	4-17
SECTION 5	CONCLUSION .....	5-1

## Appendices

---

Appendix A	Existing Traffic Volumes
Appendix B	Memorandum on Recommended Design Hour Traffic Factors and Development of Existing and Future Traffic Volumes
Appendix C	Existing Signal Timings
Appendix D	Existing Year 2013 Level of Service
Appendix E	Traffic Methodology Statement
Appendix F	Design Year 2040 No-Build and Build Level of Service
Appendix G	Interim Year 2030 No-Build and Build Level of Service
Appendix H	Opening Year 2020 No-Build and Build Level of Service
Appendix I	Intersection Turn Lane Storage Lengths
Appendix J	Traffic Forms for Noise and Air Studies
Appendix K	FDOT Comment-Responses and Meeting Minutes

## List of Figures and Tables

### **Figures**

Figure 1-1	Study Area Map .....	2-2
Figure 1-2	Existing Roadway Typical Sections.....	2-3
Figure 1-3	Existing Bridge Typical Sections .....	2-4
Figure 1-4	Planned Urban Typical Sections.....	2-6
Figure 1-5	Planned Suburban Typical Sections .....	2-7
Figure 1-6	Planned Bridge Typical Sections .....	2-8
Figure 2-1	Existing Lane Geometry .....	2-2
Figure 2-2	Existing (2013) Annual Average Daily Traffic (AADT).....	2-6
Figure 2-3	Existing (2013) AM and PM Peak Hour Traffic Volumes.....	2-8
Figure 2-4	Distribution of Crashes (2008-2012) by Milepost along US 41 from Kracker Avenue to South of SR 676 (Causeway Boulevard).....	2-14
Figure 2-5	Crashes Types along US 41 from Kracker Avenue to south of SR 676.....	2-1
Figure 3-1	Future Year No-Build and Build Annual Average Daily Traffic (AADTS).....	3-3
Figure 3-2	Opening Year (2020) No-Build and Build AM and PM Peak Hour Traffic Volumes .....	3-4
Figure 3-3	Interim Year (2030) No-Build and Build AM and PM Peak Hour Traffic Volumes .....	3-5
Figure 3-4	Design Year (2040) No-Build and Build AM and PM Peak Hour Traffic Volumes .....	3-6
Figure 4-1	Design Year (2040) Build Lane Geometry Required for Acceptable LOS.....	4-7
Figure 4-2	FDOT Approved Lane Geometry (Planned Improvements).....	4-10

### **Tables**

Table 2-1	Recommended K, D, T Factors along US 41 .....	2-5
Table 2-2	Existing Year (2013) AM/PM Intersection Delay and Level of Service Summary.....	2-9
Table 2-3	Existing Year (2013) AM/PM Roadway Segment Speed and Level of Service Summary .....	2-10
Table 2-4	Summary of Crash Analysis along US 41 .....	2-11
Table 2-5	Summary of Crash Analysis along US 41 by Crash Types .....	2-1
Table 4-1	Planning Level Signal Warrant Evaluation at Unsignalized Intersections .....	4-3
Table 4-2	Design Year (2040) No-Build AM/PM Intersection Delay and Level of Service Summary .....	4-4
Table 4-3	Design Year (2040) No-Build AM/PM Roadway Segment Speed and Level of Service Summary.....	4-5
Table 4-4	Design Year (2040) Build AM/PM Intersection Delay and Level of Service Summary .....	4-6
Table 4-5	Design Year (2040) Build AM/PM Roadway Segment Speed and Level of Service Summary .....	4-8
Table 4-6	Interim Year (2030) No-Build AM/PM Intersection Delay and Level of Service Summary .....	4-9
Table 4-7	Interim Year (2030) No-Build AM/PM Roadway Segment Speed and Level of Service Summary.....	4-11
Table 4-8	Interim Year (2030) Build AM/PM Intersection Delay and Level of Service Summary .....	4-12
Table 4-9	Interim Year (2030) Build AM/PM Roadway Segment Speed and Level of Service Summary .....	4-13

Table 4-10	Opening Year (2020) No-Build AM/PM Intersection Delay and Level of Service Summary .....	4-14
Table 4-11	Opening Year (2020) No-Build AM/PM Roadway Segment Speed and Level of Service Summary.....	4-15
Table 4-12	Opening Year (2020) Build AM/PM Intersection Delay and Level of Service Summary .....	4-16
Table 4-13	Opening Year (2020) Build AM/PM Roadway Segment Speed and Level of Service Summary.....	4-17
Table 4-14	Design Year (2040) Build Recommended Turn Lane Lengths.....	4-18



## Acronyms

AADT	Annual Average Daily Traffic
DDHV	Directional Design Hour Volumes
Department	Florida Department of Transportation
DHV	Design Hour Volume
DHT	Design Hour Truck
DTTM	Design Traffic Technical Memorandum
FDOT	Florida Department of Transportation
FTI	Florida Transportation Information
HCS	Highway Capacity Software
LOS	Level of Service
L RTP	Long Range Transportation Plan
MPH	Miles per Hour
MPO	Metropolitan Planning Organization
MUTCD	Manual on Uniform Traffic Control Devices
MUTS	Manual on Uniform Traffic Studies
NCHRP	National Cooperative Highway Research Program
PD&E	Project Development & Environment
SR	State Road
US	United States Highway
TAZ	Traffic Analysis Zone
TBRPM	Tampa Bay Regional Planning Model
V/C Ratio	Volume/Capacity Ratio

## **SECTION 1 INTRODUCTION**

### **1.1 PD&E STUDY PURPOSE**

The objective of this Project Development and Environment (PD&E) study was to assist the Florida Department of Transportation (FDOT) in reaching a decision on the type, location, and conceptual design of the proposed improvements for widening US 41 (SR 45) from Kracker Avenue to south of Causeway Boulevard (SR 676). The PD&E study satisfied all applicable requirements in order for this project to qualify for state funding of subsequent project development phases (design, right of way [ROW] acquisition, and construction).

US 41 is a major north-south arterial of regional significance that parallels Interstate 75 (I-75) and US 301 in Hillsborough County. This project was screened through FDOT's Efficient Transportation Decision Making (ETDM) process as Project #5180. A *Final Programming Screen Summary Report* was published on April 10, 2013. A *State Environmental Impact Report* (SEIR) was prepared as part of this study and approved on January 12, 2017.

### **1.2 PROJECT DESCRIPTION**

The FDOT conducted a PD&E study to evaluate alternative capacity and operational improvements to US 41 from Kracker Avenue (milepoint 15.784) to south of Causeway Boulevard (milepoint 22.791) in Hillsborough County (**Figure 1-1**), a distance of approximately 7.0 miles. The highway is to be improved from an existing, four-lane divided rural and urban facility to a six-lane divided facility. Bridges over Bullfrog Creek and the Alafia River are planned to be replaced. The planned improvements will include construction of stormwater management and floodplain compensation facilities and various intersection improvements, in addition to multimodal facilities (trail, pedestrian, bicycle and transit accommodations). However, the PD&E study for the proposed project did not evaluate specific stormwater management facilities and floodplain compensation sites as these locations will be identified during the proposed project's future design phase.

### **1.3 EXISTING FACILITY AND PLANNED IMPROVEMENTS**

US 41 currently has both four-lane divided rural and urban typical sections (**Figure 1-2**). In addition, a 0.9-mile segment near the north end, between Denver Street and SR 676, was previously widened to a six-lane urban section. Existing lane widths vary from 11 to 12 feet and median widths vary from 19 to 40 feet. The rural typical section areas include 4-foot paved shoulders. The posted speed limit is 50 miles per hour (mph) in the north Gibsonton area and 55 mph in the areas to the south and north. The existing right of way width varies from 100 feet in north Gibsonton to 182 feet in the areas to the south and north. Existing bridge typical sections are shown in **Figure 1-3**.

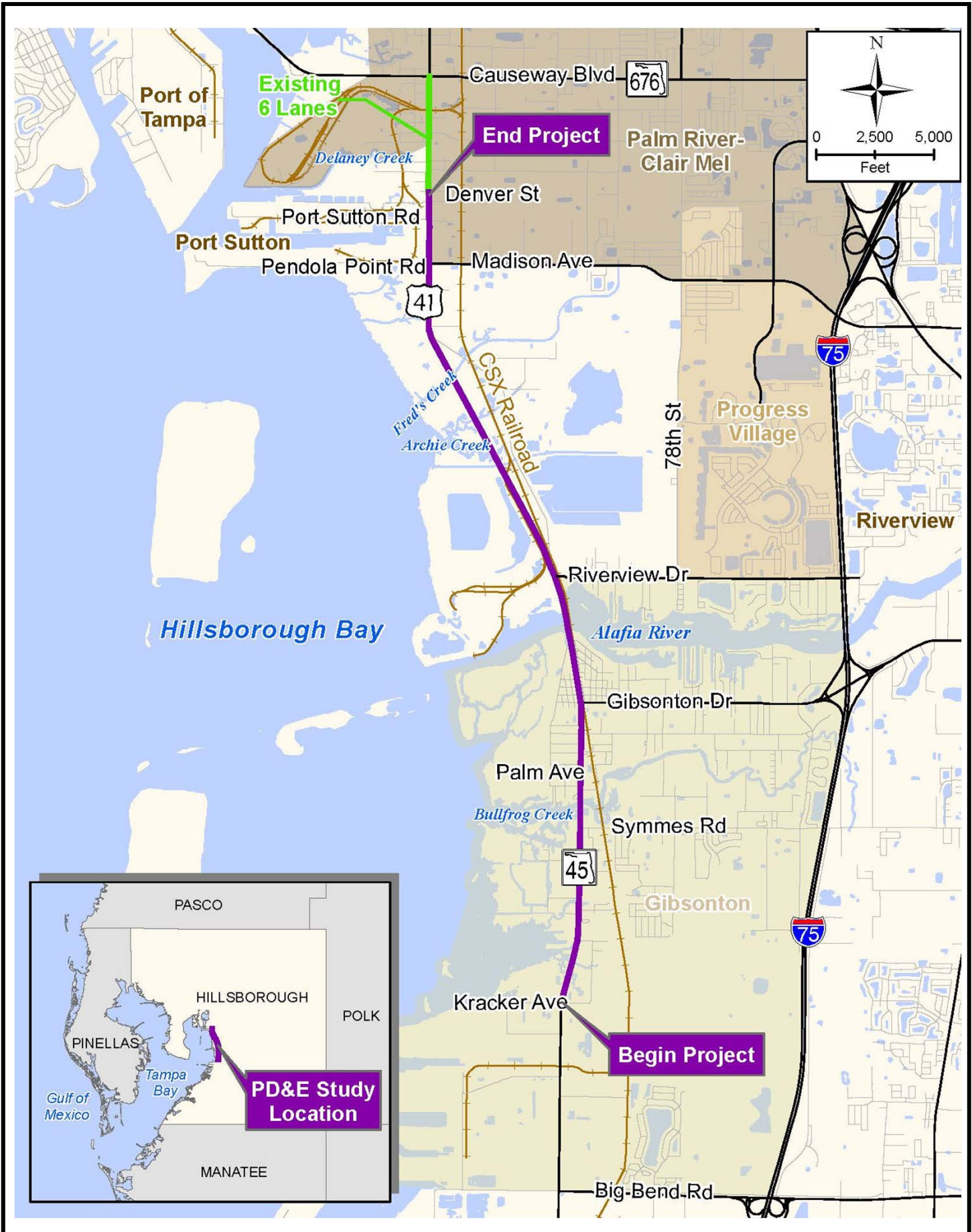

**US 41(SR 45) PD&E Study**  
 From Kracker Avenue to South of SR 676  
 (Causeway Blvd)  
 WPI Segment No. 430056-1 Hillsborough County

**Location and Study Area Map**

**Figure 1-1**



(All views are looking north)

- 23 Causeway Blvd
- 6-Lane Urban**
- 23 Delaney Creek
- Denver Street
- Port Sutton Rd
- 22 Madison Av/ Pendola Pt
- #1**
- 21 Fred's Creek
- Archie Creek 1
- Archie Creek 2
- 20
- Riverview Drive
- Alafia River Br
- Alafia River Br
- Lula St
- #2**
- Gibsonton Drive
- #3**
- 18 Palm Avenue
- Bullfrog Creek
- Symmes Road
- 17
- #4**
- 16 Kracker Avenue

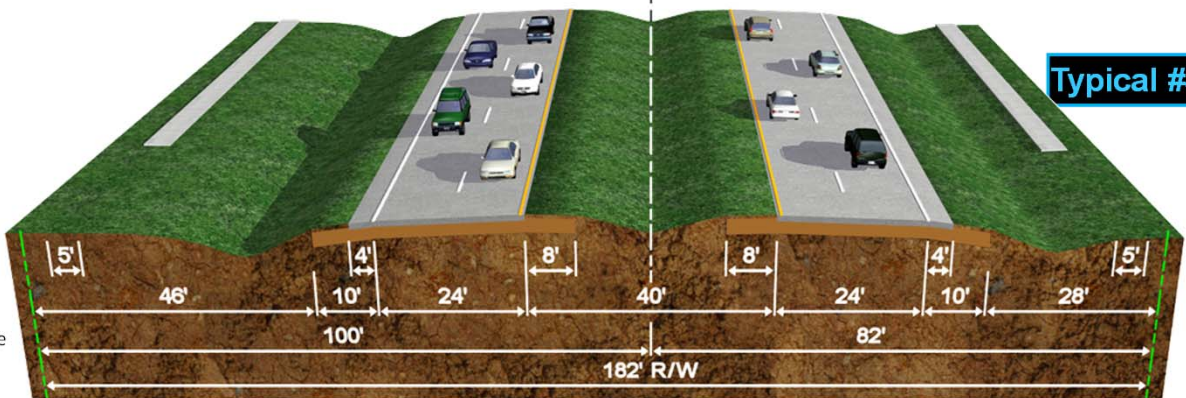
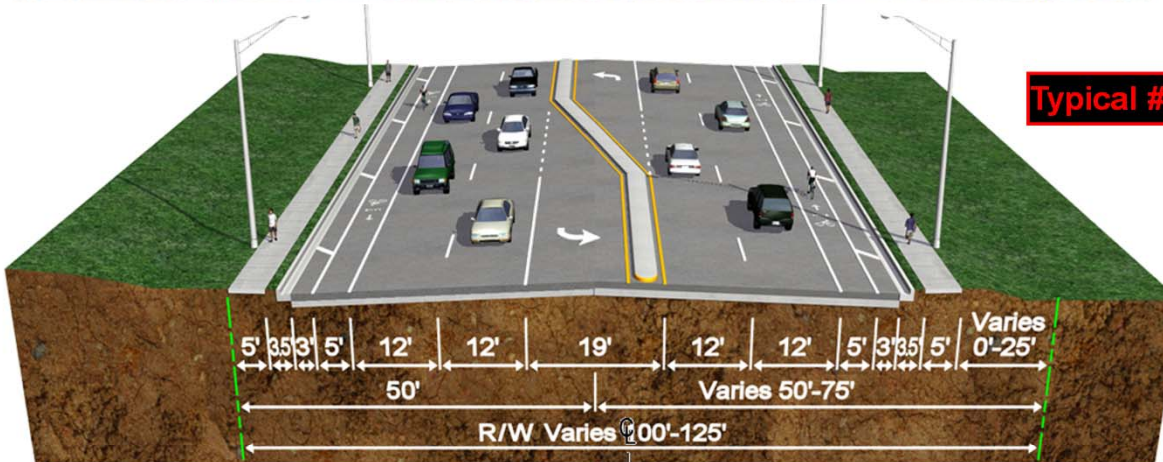
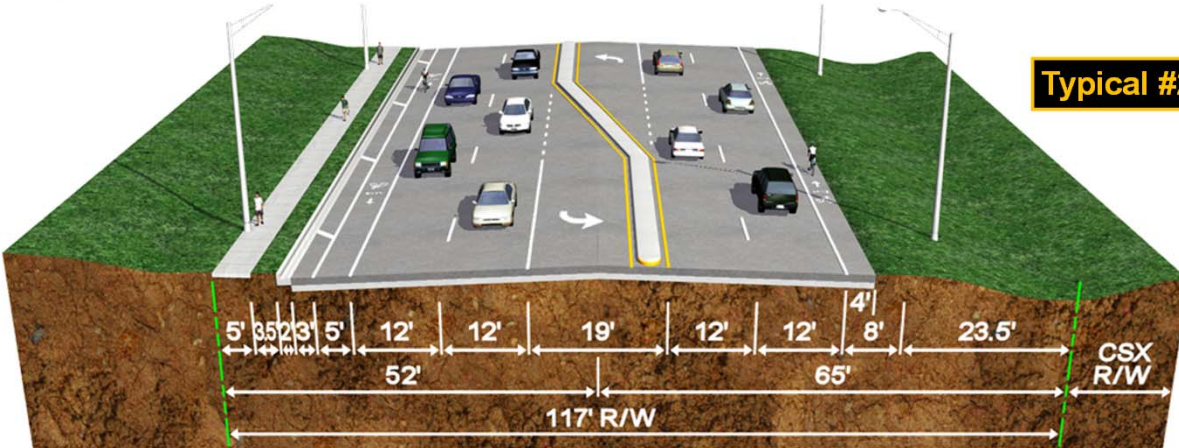
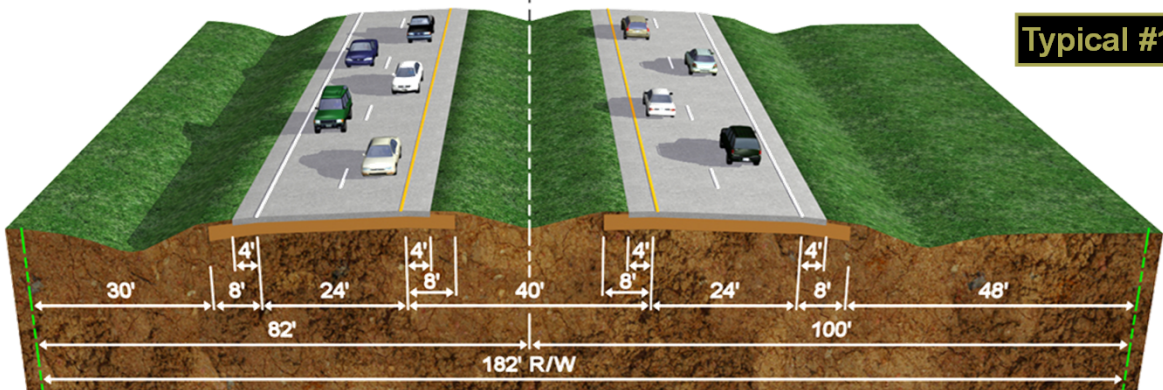

**US 41(SR 45) PD&E Study**  
 From Kracker Avenue to South of SR 676  
 (Causeway Blvd)  
 WPI Segment No. 430056 1 - Hillsborough County

**Existing Roadway  
 Typical Sections**

**Figure 1-2**

### Existing Bridges over the Alafia River (Looking North)

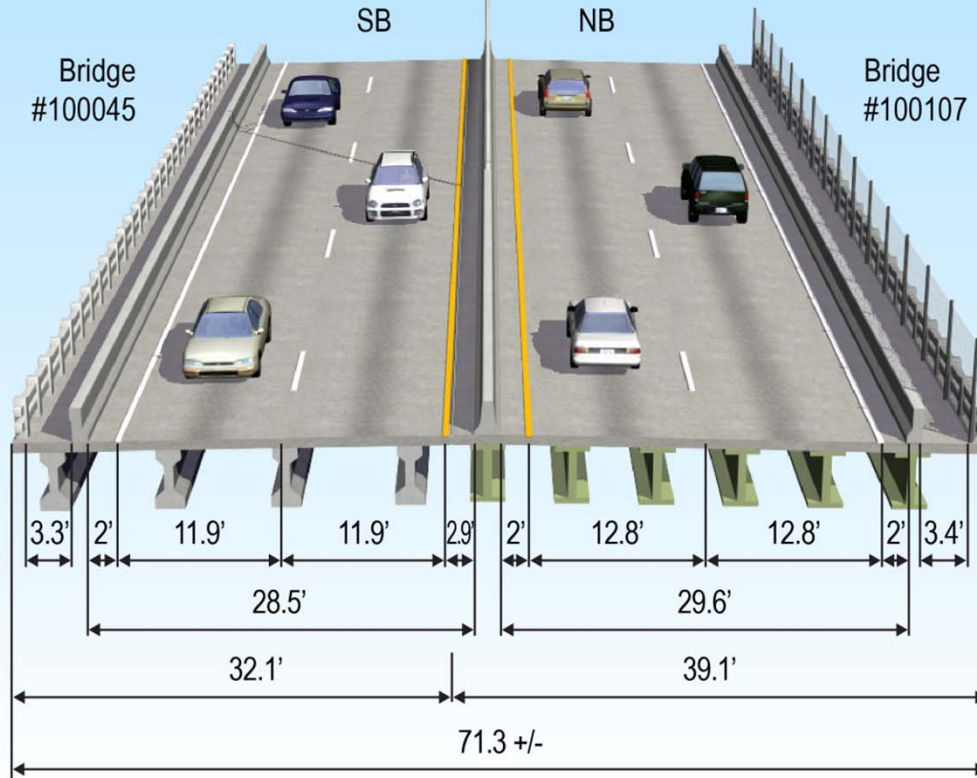

### Existing Bridges over Bullfrog Creek (Looking North)

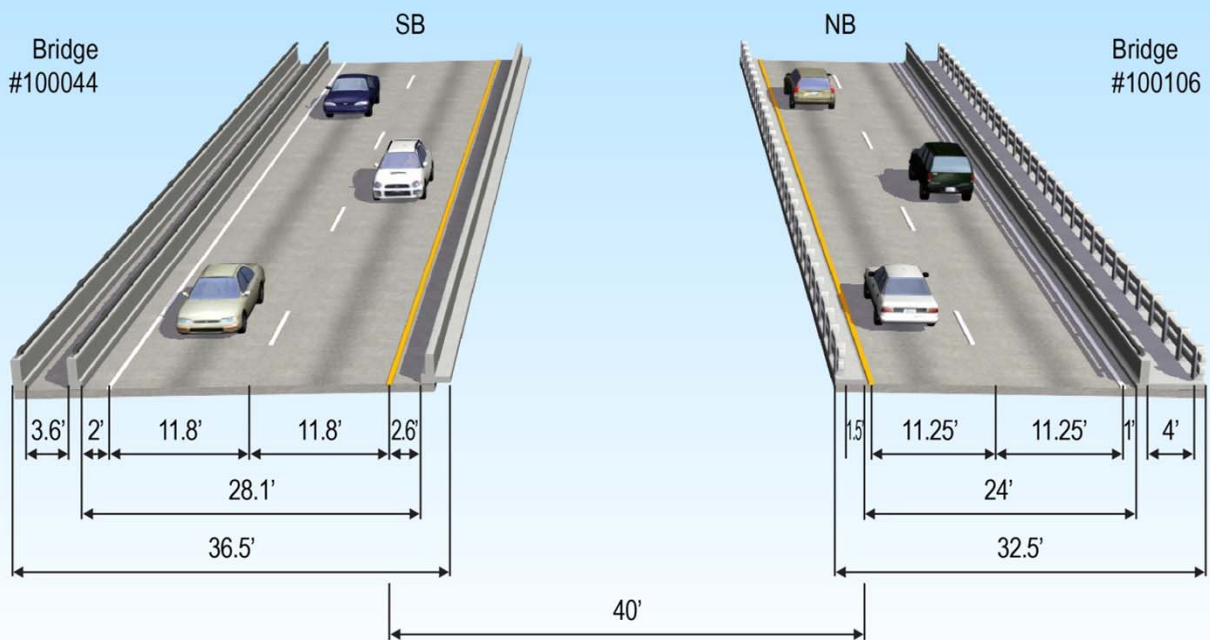

Rev. 2/2014



**US 41(SR 45) PD&E Study**  
 From Kracker Avenue to South of SR 676  
 (Causeway Blvd)  
 WPI Segment No. 430056 1 - Hillsborough County

**Existing Bridge  
 Typical Sections**

**Figure 1-3**

Planned improvements include widening to six lanes as well as intersection improvements, construction of stormwater management and floodplain compensation facilities and multimodal facilities. Planned typical sections include both suburban and urban typical sections. Additional right of way will be required in the north Gibsonton area for the planned improvements. Alternatives to replace the bridges at Bullfrog Creek and the Alafia River were evaluated. Planned typical sections are shown in **Figures 1-4, 1-5 and 1-6**. A “No-Build” Alternative was also evaluated. No future phases for this proposed project are included in FDOT’s current adopted 5-year work program (Fiscal Years 16/17 through 20/21).

#### **1.4 PROJECT PURPOSE AND NEED**

US 41 within the study area plays a significant role in connecting southern Hillsborough County to the Tampa Bay region. The purpose of the proposed project is to accommodate future traffic demands on US 41 due to growth within the project limits and surrounding areas. Segments within this corridor are projected to operate at level of service (LOS) F in the design year (2040) if no increase in capacity is provided. Additional factors which support the need for the project include:

**Regional Connectivity** - US 41 is a major north-south regional arterial that parallels I-75 and US 301 and connects south Hillsborough County to the Tampa Bay region. It provides connectivity between the communities of Apollo Beach, Riverview, and Gibsonton. US 41 is a “regional road” according to the West Central Florida Metropolitan Planning Organization’s (MPO’s) Chairs Coordinating Committee (CCC). US 41 also provides highway access to the Port of Tampa facilities at Pendola Point and Port Sutton.

**Safety** - With the additional capacity provided in the corridor by the widening of US 41 from four to six lanes, roadway congestion will be reduced, which will decrease potential conflicts with other vehicles and potentially increase safety. An analysis of traffic crash data for years 2008 thru 2012 revealed that the overall average crash rate within the study limits was lower than the statewide average crash rate for similar type facilities. While not structurally deficient, the bridges over both Bullfrog Creek and the Alafia River are classified as *functionally obsolete* due to substandard-width shoulders. In addition, the sidewalks on the bridges are very narrow and there are no dedicated bicycle facilities.

**Plan Consistency** - This project is consistent with the Comprehensive Plan for Unincorporated Hillsborough County. The Hillsborough County *Imagine 2040 Long-Range Transportation Plan (LRTP)* indicates a need to widen US 41 to 6-lanes from 19<sup>th</sup> Avenue to north of Madison Avenue, “beyond 2040”. In addition, a short segment between Madison Avenue and Causeway Boulevard is shown as 6 lanes in the Cost Feasible FDOT Strategic Intermodal System Projects, with design after year 2026.

(All views are looking north)

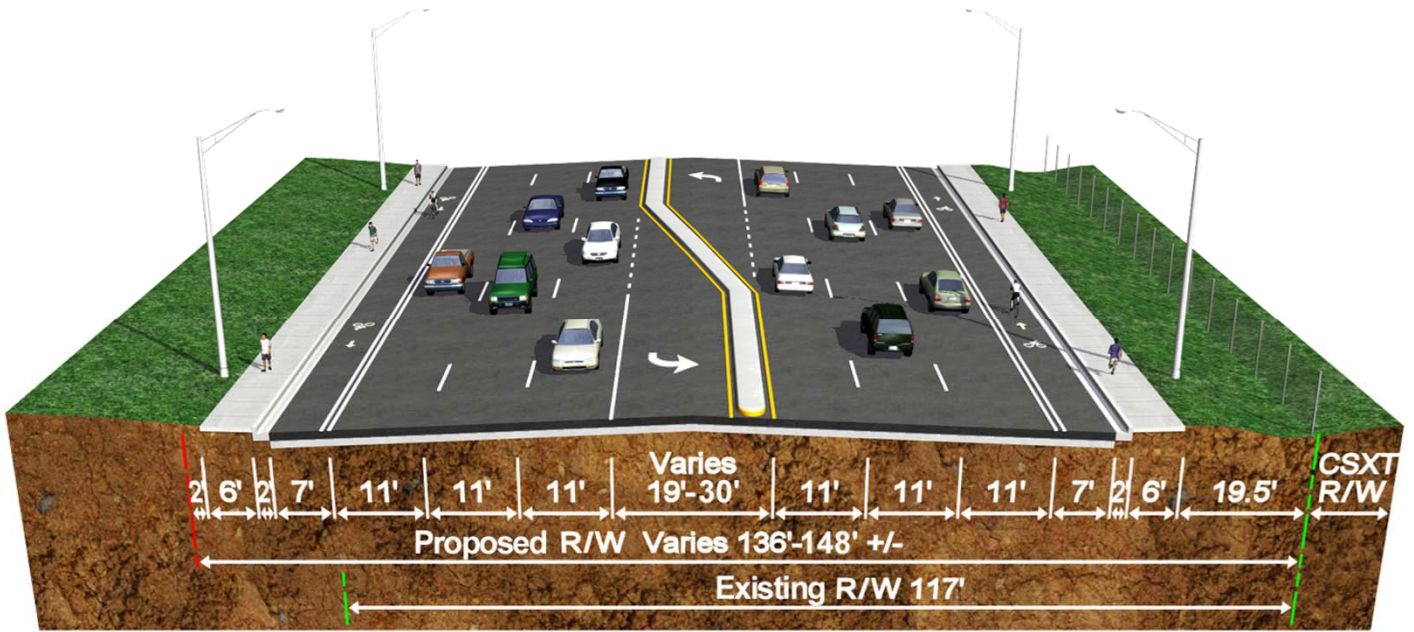

**From Gibsonton Drive to Lula Street**

Design Speed = 45 mph

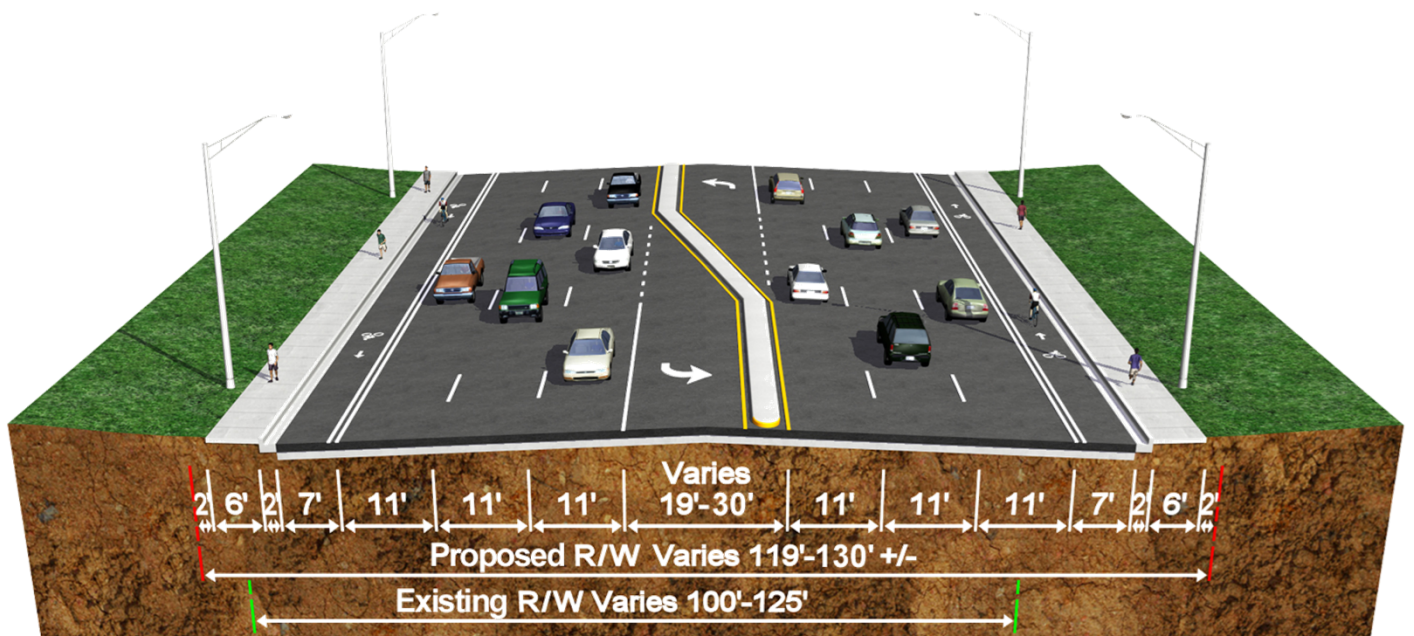

**From Palm Avenue to Gibsonton Drive**

Design Speed = 45 mph

Rev. 3/14/16



US 41(SR 45) PD&E Study  
 From Kracker Avenue to South of SR 676  
 (Causeway Blvd)  
 WPI Segment No. 430056 1 - Hillsborough County

**Planned Urban  
 Typical Sections**

**Figure 1-4**

## Suburban Alternatives Utilizing the Existing Pavement

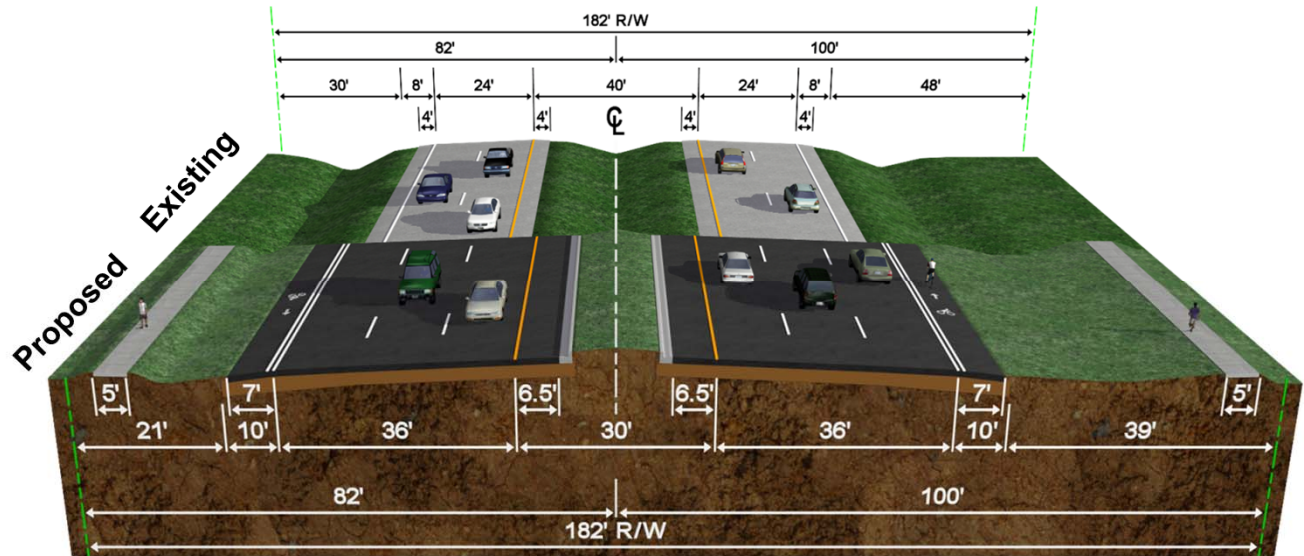

- Provides 50 mph design speed (required for SIS Connector Segment north of Pendola Point)
- Design variation for border width required
- No additional ROW required

### Between Alafia River Bridge & Denver Street (Near the North End of the Project)

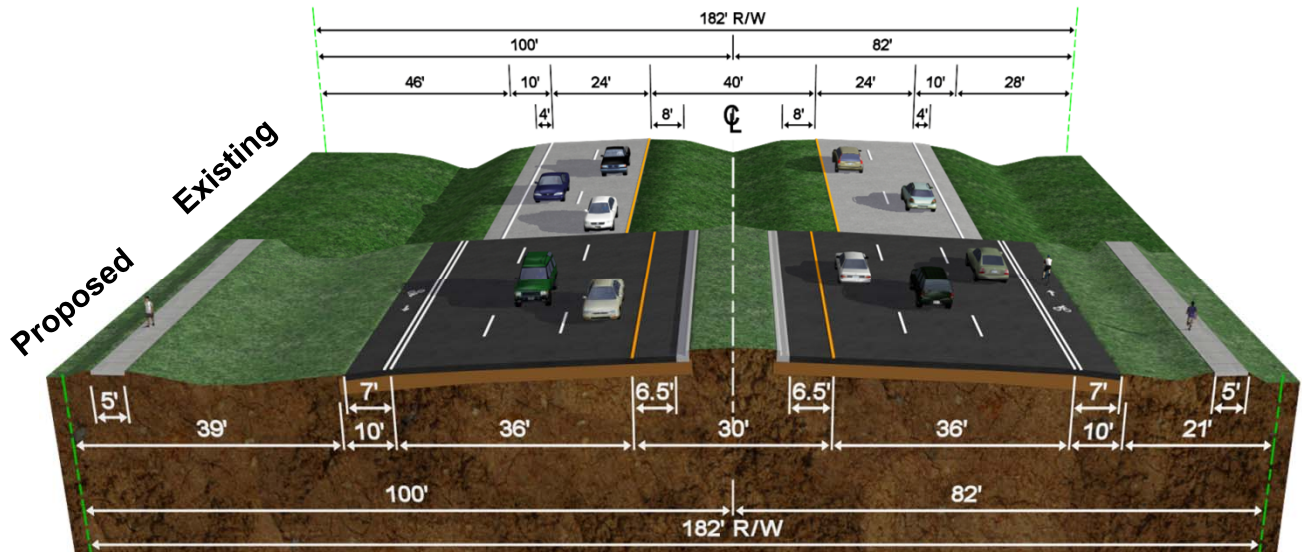

- Provides 50 mph design speed
- Design variation for border width required
- No additional ROW required

### Between Kracker Ave. & Palm Ave. (Near the South End of the Project)

(All views are looking north)

Rev. 10/12/16



**US 41(SR 45) PD&E Study**  
 From Kracker Avenue to South of SR 676  
 (Causeway Blvd)  
 WPI Segment No. 430056 1 - Hillsborough County

**Planned Suburban  
 Typical Sections**

**Figure 1-5**



(All views are looking north)

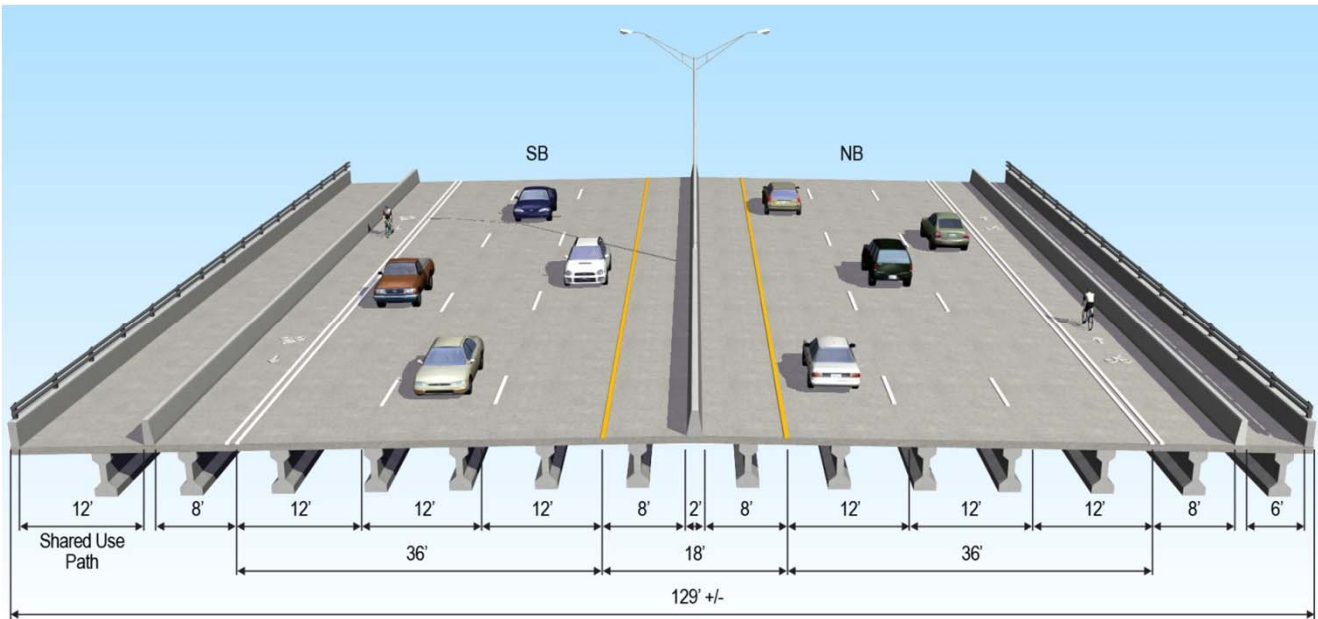

**Bridge at Alafia River**

Design Speed = 50 mph

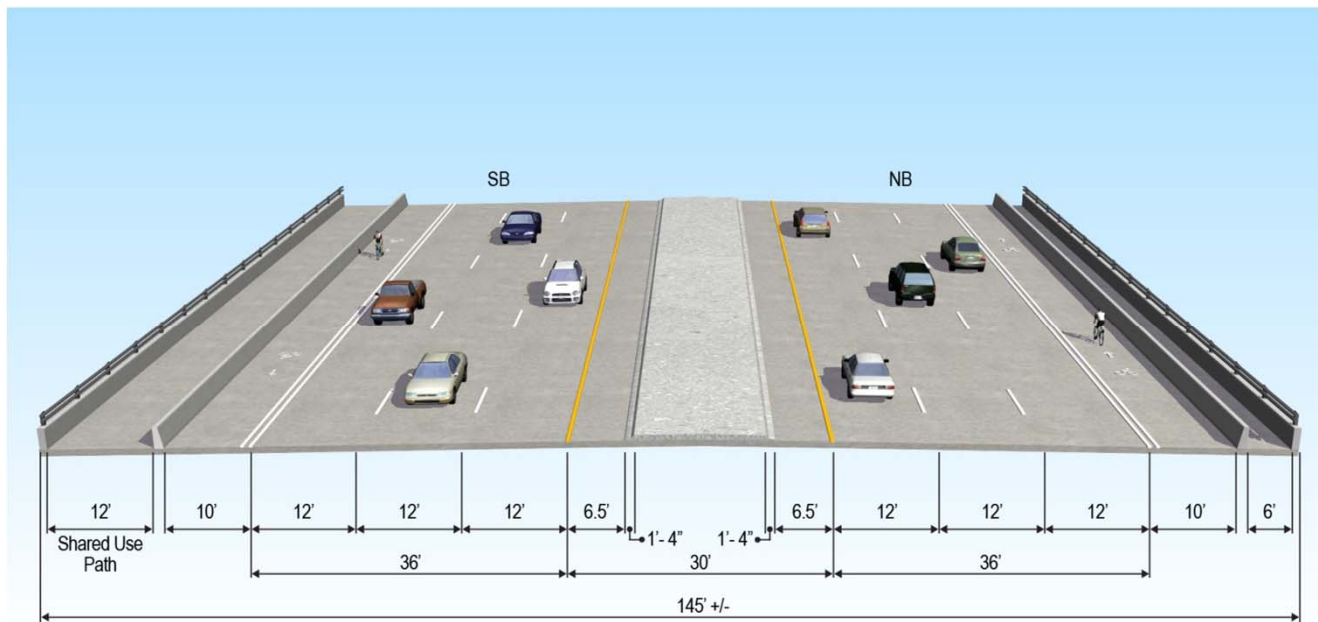

**Bridge at Bullfrog Creek**

Design Speed = 50 mph

Rev. 10/12/16



**US 41(SR 45) PD&E Study**  
 From Kracker Avenue to South of SR 676  
 (Causeway Blvd)  
 WPI Segment No. 430056 1 - Hillsborough County

**Planned Bridge  
 Typical Sections**

**Figure 1-6**

**Emergency Evacuation** - US 41 is listed as an evacuation route by the Hillsborough County Emergency Management and shown on the Florida Division of Emergency Management's evacuation route network. US 41 provides access to I-75 via interchanges with east-west connections on Gibsonton Drive, Big Bend Road (CR 672) and SR 60 in close proximity to the study limits.

**Current and Future Transportation Demand** - Traffic in the corridor is expected to increase due to projected population and employment growth along the corridor. In 2013, the Annual Average Daily Traffic (AADT) ranged between 23,400 vehicles per day (VPD) (Level of Service [LOS] B) and 36,400 VPD (LOS B) within the study area according to the *Traffic Technical Memorandum*. With a maximum AADT of 32,350 VPD over the four lane section, US 41 is at 88 percent capacity for the adopted level of service standard of D. In 2040, AADTs are expected to range between 38,800 VPD and 61,000 VPD. The existing four lane cross section would result in a LOS F in some segments with the future projected traffic volumes. The widening of this facility is also intended to provide relief to parallel facilities such as I-75 and US 301.

**Modal Interrelationships** – Expansion of the existing roadway would help improve mobility for the Hillsborough Area Regional Transit (HART) Authority local bus route 31 within the corridor. Bicycle and pedestrian accommodations will also be considered as part of the proposed improvements.

US 41 is part of the highway network that provides access to regional intermodal facilities such as the Port of Tampa and Port Manatee. The segment of US 41 between Madison Avenue/Pendola Point Road and SR 676 is designated as a Strategic Intermodal System (SIS) *connector*. The SIS is a statewide network of highways, railways, waterways, and transportation hubs that handle the bulk of Florida's passenger and freight traffic. Improvements to US 41 would enhance access to activity centers in the area and would improve movement for goods and freight in the Tampa Bay region and across the State.

## **1.5 REPORT PURPOSE**

This *Design Traffic Technical Memorandum (DTTM)* is one of several documents that were prepared as part of this PD&E study. The purpose of this *Design Traffic Technical Memorandum (DTTM)* is to document the need for future widening of the US 41 project corridor and identify the roadway improvements required within the project limits from Kracker Avenue (southern limit) to the south of SR 676 (Causeway Boulevard) (northern limit) for improved traffic operation. The analyses performed in this DTTM are to support decisions related to project alternatives. In addition, this DTTM summarizes existing conditions, development of existing and future traffic projections and analysis of existing and future traffic conditions along with proposed recommendations.

## SECTION 2 EXISTING CONDITIONS & TRAFFIC

### 2.1 ROADWAY AND INTERSECTION CHARACTERISTICS

US 41 from Kracker Avenue to Port Sutton Road is a four-lane divided arterial roadway which then transitions to a five-lane divided roadway north of Port Sutton Road to Denver Street and thereafter, transitions to a six-lane divided roadway from Denver Street to south of SR 676 (Causeway Boulevard). The posted speed limit on US 41 (Roadway ID No. 10-060-000) within the project limit varies between 40 mph and 55 mph. The existing year (2013) US 41 arterial signalized intersection locations and primary unsignalized intersection locations along with intersection lane geometry are shown on **Figure 2-1**.

### 2.2 TRAFFIC CHARACTERISTICS

A comprehensive traffic count program was performed for the US 41 study corridor. The counts were collected by Southern Traffic Services, Inc. predominantly during the months of January and March of 2013. The traffic count data included 72-hour classification counts performed at three locations, 72-hour approach machine counts performed at approaches of the study intersections, and 4-hour turning movement counts performed at twelve key study intersections along the study corridor. The collected field traffic count data is included in **Appendix A**.

The 72-hour bi-directional classification counts were conducted at the following locations:

- US 41 – Between Kracker Avenue and Gibsonton Drive/Alice Avenue
- US 41 – Between Gibsonton Drive/Alice Avenue and CR 676A (Madison Avenue/Pendola Point Road)
- US 41 – Between CR 676A (Madison Avenue/Pendola Point Road) and south of SR 676 (Causeway Boulevard)

The 72-hour bi-directional volume counts were conducted at the following locations:

- US 41 – South of Kracker Avenue
- US 41 – North of Kracker Avenue
- Kracker Avenue – East of US 41
- US 41 – South of Ohio Street
- US 41 – North of Ohio Street
- Ohio Street – East of US 41
- US 41 – South of Florence Street
- US 41 – North of Florence Street
- Florence Street – East of US 41
- Florence Street – West of US 41
- US 41 – South of Symmes Road
- US 41 – North of Symmes Road

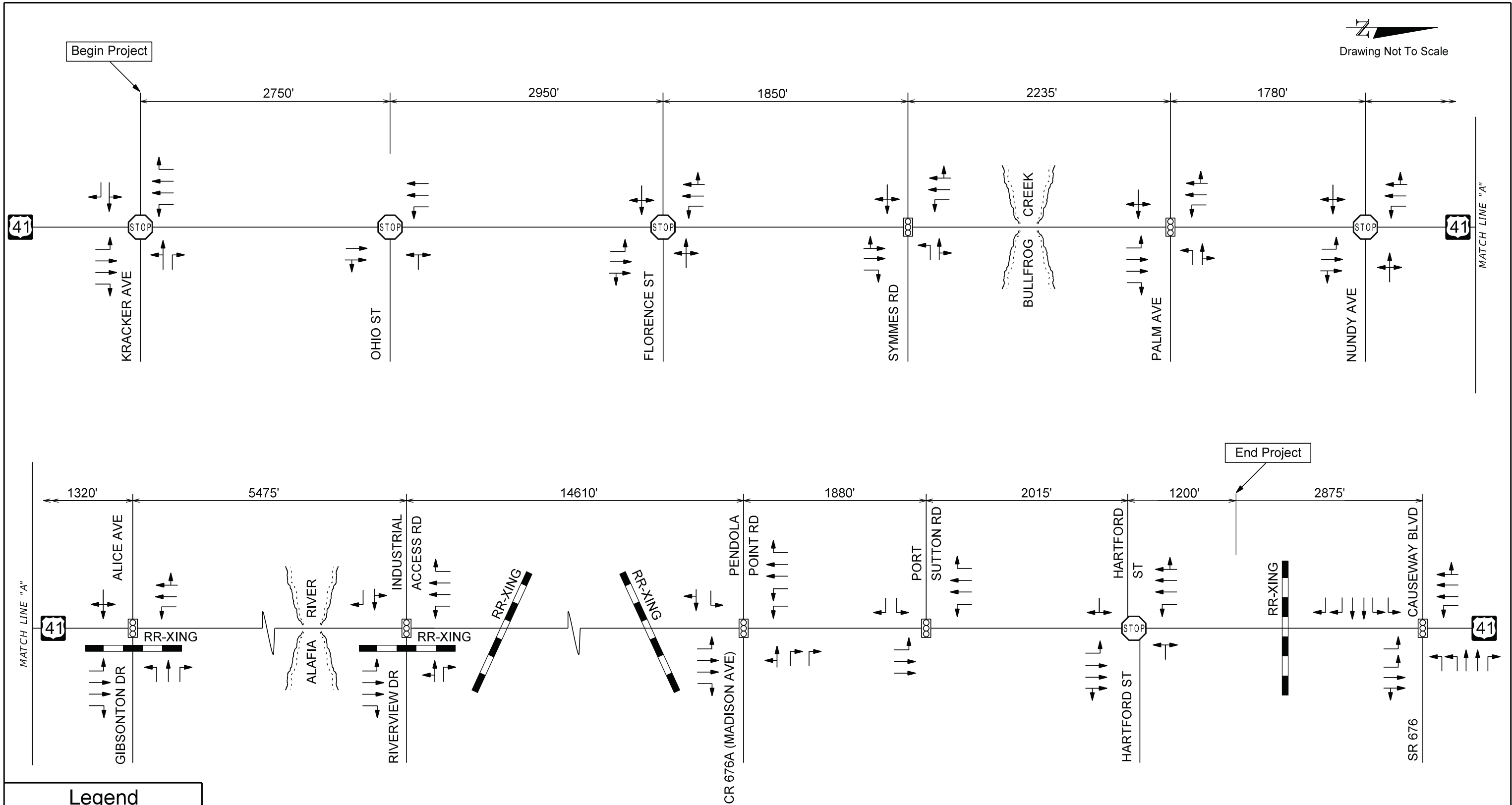

Legend	
	TRAFFIC SIGNAL
	STOP SIGN (SIDE STREET ONLY)
	LANES
	DISTANCE IN FEET
	RAILROAD CROSSING

NOTE:  
NOT ALL SIDE STREETS ARE SHOWN,  
ONLY INTERSECTIONS ANALYZED ARE SHOWN.

**US 41 PD&E Study**  
From Kracker Avenue to South  
of SR 676 (Causeway Boulevard)  
WPI Number: 430056-1  
Hillsborough County

Existing Lane Geometry

Figure 2-1

- Kracker Avenue – West of US 41
- Symmes Road – East of US 41
- US 41 – South of Palm Avenue
- US 41 – North of Palm Avenue
- Palm Avenue – West of US 41
- US 41 – South of Nundy Avenue
- US 41 – North of Nundy Avenue
- Nundy Avenue – East of US 41
- Nundy Avenue – West of US 41
- US 41 – South of Gibsonton Drive/Alice Avenue
- US 41 – North of Gibsonton Drive/Alice Avenue
- Gibsonton Drive/Alice Avenue – East of US 41
- Gibsonton Drive/Alice Avenue – West of US 41
- US 41 – South of Riverview Drive/Industrial Access Road
- US 41 – North of Riverview Drive/Industrial Access Road
- Riverview Drive/Industrial Access Road – East of US 41
- Riverview Drive/Industrial Access Road – West of US 41
- US 41 – South of CR 676A (Madison Avenue/Pendola Point Road)
- US 41 – North of CR 676A (Madison Avenue/Pendola Point Road)
- CR 676A (Madison Avenue/Pendola Point Road) – East of US 41
- CR 676A (Madison Avenue/Pendola Point Road) – West of US 41
- US 41 – South of Port Sutton Road
- US 41 – North of Port Sutton Road
- Port Sutton Road – West of US 41
- US 41 – South of Hartford Street
- US 41 – North of Hartford Street
- Hartford Street – East of US 41
- Hartford Street – West of US 41
- US 41 – South of SR 676 (Causeway Boulevard)
- US 41 – North of SR 676 (Causeway Boulevard)
- SR 676 (Causeway Boulevard) – East of US 41
- SR 676 (Causeway Boulevard) – West of US 41

The 4-hour turning movement counts <sup>(1)</sup> were conducted between 7:00 AM – 9:00 AM and 4:00 PM – 6:00 PM at the following study intersections:

- US 41 at Kracker Avenue (Unsignalized)
- US 41 at Ohio Street (Unsignalized)

- US 41 at Florence Street (Unsignalized)
- US 41 at Symmes Road (Signalized)
- US 41 at Palm Avenue (Signalized)
- US 41 at Nundy Avenue (Unsignalized)
- US 41 at Gibsonton Drive/Alice Avenue (Signalized)
- US 41 at Riverview Drive/Industrial Access Road (Signalized) <sup>(2)</sup>
- US 41 at CR 676A (Madison Avenue/Pendola Point Road) (Signalized) <sup>(2)</sup>
- US 41 at Port Sutton Road (Signalized) <sup>(2)</sup>
- US 41 at Hartford Street (Unsignalized)
- US 41 at SR 676 (Causeway Boulevard) (Signalized) <sup>(3)</sup>

<sup>(1)</sup> Based upon the 72-hour counts, traffic during mid-day hours were not observed as controlling the operational parameters, so only AM and PM peak hours were considered for the turning movement counts.

<sup>(2)</sup> These intersections provide direct connection to the Port of Tampa facilities. Additional turning movement counts were conducted between 9 am and 1 pm when truck traffic was observed to be the highest at these intersections of Riverview Drive, Madison Avenue and Port Sutton Road providing direct access to the Port facilities. These special counts were conducted in order to size the future turn lanes at these intersections so that they can accommodate high-volume truck movements made throughout an average day. These additional counts are also included in **Appendix A**.

<sup>(3)</sup> For this intersection traffic volumes were collected as a part of the scope so that it can be used in future study. The intersection of US 41 and SR 676 (Causeway Boulevard) was not studied as a part of this project. This intersection has been evaluated for grade separation under Financial Project ID Number 255599-1-32-02 – Traffic Operations Analysis for SR 676 (Causeway Boulevard) from SR 45 (US 41) to SR 43 (US 301).

### **2.3 TRAFFIC PARAMETERS**

The design hour traffic factors recommended for the US 41 PD&E study include a standard K factor of 9.0% per the *2012 Project Traffic Forecasting Handbook* along US 41 and all the side-streets. The recommended D-factor along the US 41 study corridor is 64.27% based on the average of the D-factors obtained from the 72-hour classification counts and the D-factor along the study corridor as identified in the *2011 Florida Transportation Information (FTI) DVD*. The recommended D-factor along US 41 is within the acceptable range identified in the *2012 FDOT Project Traffic Forecasting Handbook*. D-factor along the side-streets that were used in the development of the existing AM and PM peak hour traffic volumes were estimated from the actual AM and PM peak hour turning movement counts. Information for D-factor for US 41 and the side-streets are provided in **Appendix B**. These recommended K and D factors will be used for the development of existing and future traffic volumes.

Recommended daily truck percentage ( $T_{24}$ ) along the study corridor based on the 72-hour classification counts are 9.0% between Kracker Avenue and Gibsonton Drive/Alice Avenue and between Gibsonton Drive/Alice Avenue and CR 676A (Madison Avenue/Pendola Point Road); and, 11.0% between CR 676A (Madison Avenue/Pendola Point Road) and south of SR 676 (Causeway Boulevard). For the existing and future analysis along the side-streets, design hour truck (DHT) were used based on the AM and PM peak hour turning movement counts. DHT for US 41 is assumed to be half of  $T_{24}$ , rounded up to the nearest percent. Information on DHT for side-streets is provided in **Appendix B**.

**Table 2-1** below shows the recommended design traffic factors for the US 41 corridor. The information on the design traffic factors for US 41 were submitted to FDOT District Seven as a memorandum on *Recommended Design Hour Traffic Factors and Development of Existing and Future Traffic Volumes* and are included in **Appendix B**. These design traffic factors - K, D and T were previously accepted by FDOT on June 4, 2013.

**Table 2-1 Recommended K, D, T Factors along US 41**

US 41	Standard K	D	Daily Truck ( $T_{24}$ )	Design Hour Truck (DHT)
Kracker Avenue to Gibsonton Drive/Alice Avenue	9.00%	64.27%	9.0%	5.0%
Gibsonton Drive to CR 676A (Madison Avenue/Pendola Point Road)			9.0%	5.0%
CR 676A (Madison Avenue) to south of SR 676 (Causeway Boulevard)			11.0%	5.0%

#### **2.4 DEVELOPMENT OF EXISTING YEAR (2013) DESIGN HOUR TRAFFIC VOLUMES**



The existing design hour volumes for the AM and the PM peak periods were developed based on the seasonally adjusted annual average daily traffic (AADT) using the recommended K and the D factors along with the proportion of the existing turning movement counts.

The existing AADT volumes were obtained by applying seasonal factor and axle factor adjustment to the raw ADTs from the 72-hour approach counts. The adjustment factors were obtained from *2011 Florida Transportation Information (FTI) DVD*. These seasonally and axle adjusted existing AADT volumes in the study area are shown in **Figure 2-2**.

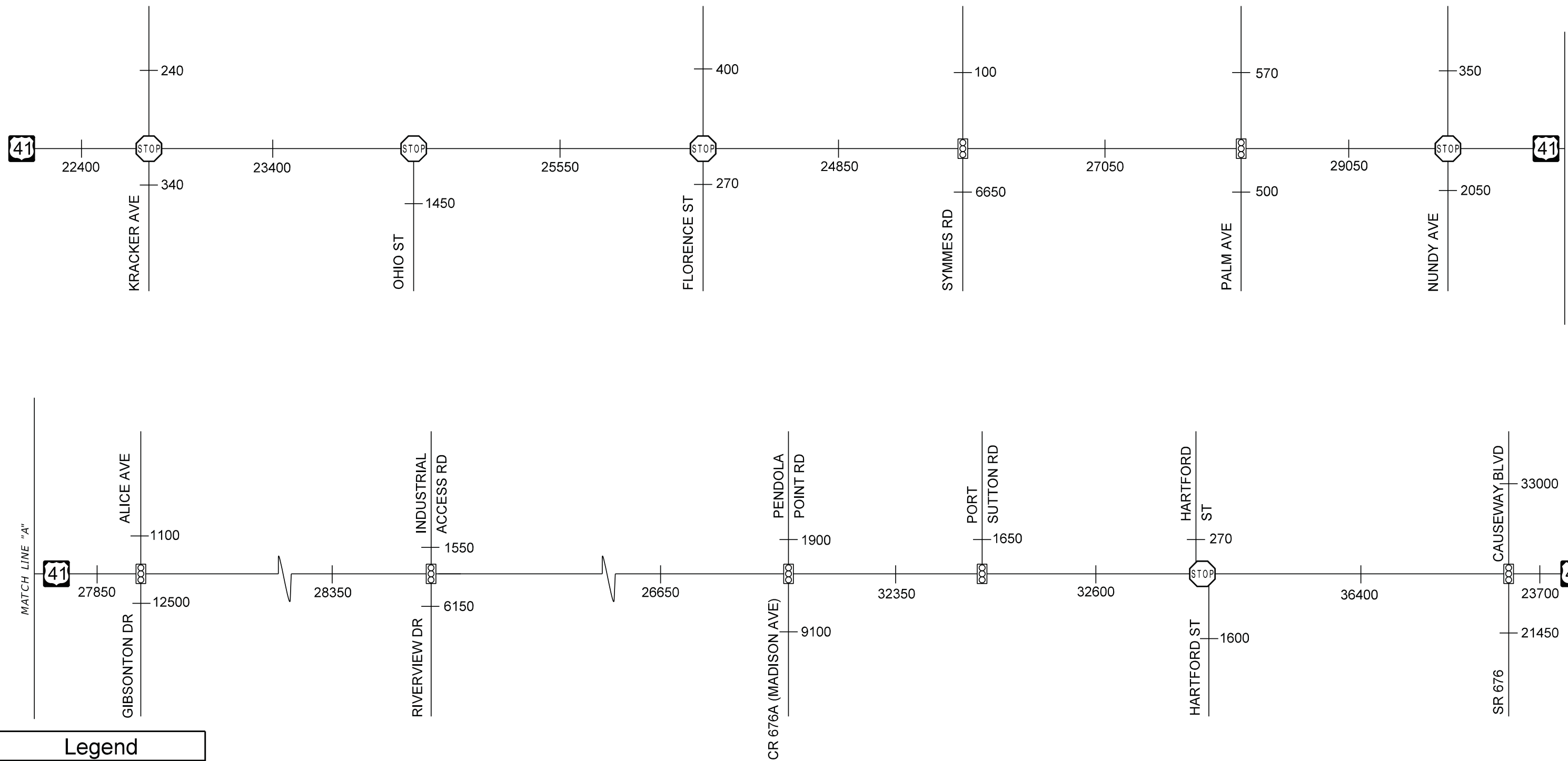
The “existing year” (2013) AM and PM peak hour directional traffic volumes (DDHV) were obtained by multiplying the existing AADT volumes by the recommended K and D factors of 9.0% and 64.27%, respectively as shown on **Table 2-1**.



**Legend**

-  TRAFFIC SIGNAL
-  STOP SIGN (SIDE STREET ONLY)
- 1234 AADTS

**US 41 PD&E Study**  
*From Kracker Avenue to South of SR 676 (Causeway Boulevard)*  
 WPI Number: 430056-1  
 Hillsborough County

Existing (2013) Annual Average Daily Traffic (AADT)

Figure 2-2





The AM and PM peak hour turning movement volumes were developed by multiplying the existing turning percentages with the DDHV estimated from AADTs. The existing turning percentages were obtained from the AM (proposed peak: 7:00am – 8:00am) and the PM (proposed peak: 4:45pm – 5:45pm) peak hour raw turning movement counts. Based on the traffic counts, southbound was considered to be the peak direction along US 41 within the project limits during the PM peak period in the development of the peak hour turning volumes. For the AM peak, northbound for US 41 (reverse of the PM peak) was used as the peak direction. Peak direction for every side-street was obtained from the existing traffic counts and is included as a part of **Appendix B**. The existing year (2013) AM and PM peak hour volumes are shown in **Figure 2-3**.

A memorandum on *Recommended Design Hour Traffic Factors and Development of Existing and Future Traffic Volumes* was prepared and approved by FDOT District Seven on June 4, 2013. This has been included in **Appendix B**. Calculation of the adjusted AADTs, DDHV and AM and PM peak hour turning movement volumes are included as a part of **Appendix B**.

## **2.5 EXISTING YEAR (2013) INTERSECTION LEVEL OF SERVICE ANALYSIS**

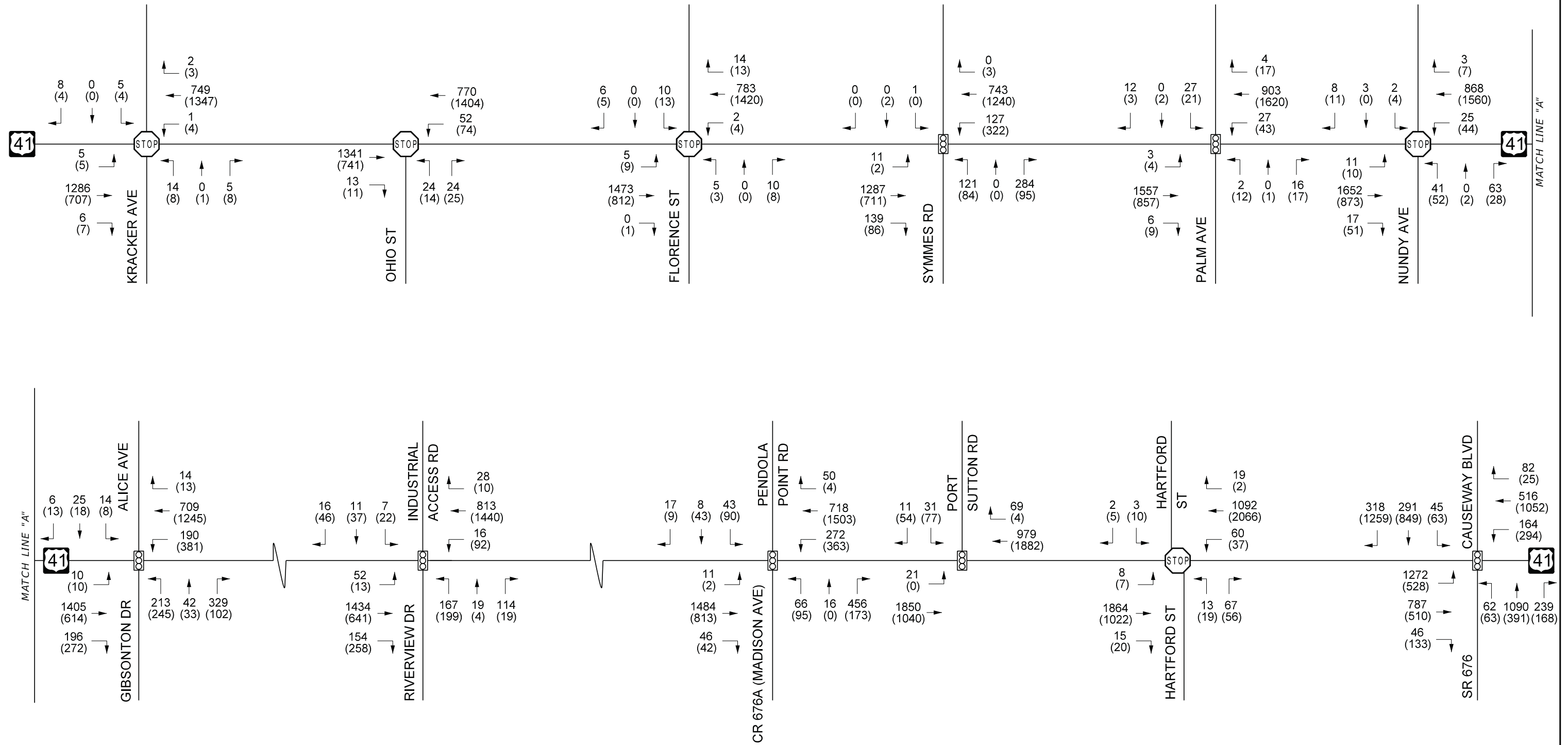
The existing year (2013) lane geometry and approved existing AM and PM peak hour traffic volumes, along with signal timing plans obtained from Hillsborough County with phasings verified from field reviews were used for the existing analysis. The existing signal timing plans are included in **Appendix C**. The acceptable LOS standard for the study corridor of US 41 in the urbanized area from Kracker Avenue to south of SR 676 (Causeway Boulevard) is 'LOS D' based on the Planning Boundaries for LOS standards for Hillsborough County. SYNCHRO Version 7.0 (Build 759) was used as the analysis tool within the study limits. Signalized intersection LOS was estimated from the Highway Capacity Manual (HCM) module of the SYNCHRO Version 7.0 (Build 759) software. The Highway Capacity Software (HCS+) Version 5.5 was used for the unsignalized intersections. The unsignalized intersection module of the Highway Capacity Software cannot analyze six lane roadways (three lanes per approach). In these cases, the unsignalized analysis is performed considering two through lanes on each approach and using two-third of the through traffic volume. This approach for the analysis of the unsignalized intersection with six lanes on the major roadway was discussed and agreed upon with FDOT. The existing year (2013) LOS and control delay results for all the study intersections are summarized in **Table 2-2**. The existing LOS analysis details (HCS output worksheets from SYNCHRO) are provided in **Appendix D**.



Legend	
	TRAFFIC SIGNAL
	STOP SIGN (SIDE STREET ONLY)
1234	AM PEAK HOUR VOLUME
(1234)	PM PEAK HOUR VOLUME

**US 41 PD&E Study**  
*From Kracker Avenue to South of SR 676 (Causeway Boulevard)*  
 WPI Number: 430056-1  
 Hillsborough County

Year 2013 AM and PM Peak Hour Traffic Volumes

Figure 2-3

**Table 2-2 Existing Year (2013) AM/PM Intersection Delay and Level of Service Summary**

Intersection	Overall Average Delay (seconds/vehicle)	Overall Intersection V/C Ratio	Overall Intersection LOS
US 41 at Kracker Avenue* (unsignalized)	30.3/24.8	-	D/C
US 41 at Ohio Street* (unsignalized)	30.2/15.9	-	D/C
US 41 at Florence Street* (unsignalized)	24.6/36.8	-	C/E
US 41 at Symmes Road	28.6/13.4	0.83/0.58	C/B
US 41 at Palm Avenue	13.3/8.6	0.70/0.61	B/A
US 41 at Nundy Avenue* (unsignalized)	106.8/27.0	-	F/D
US 41 at Gibsonton Drive/Alice Avenue	52.6/33.7	0.93/0.81	D/C
US 41 at Riverview Drive/Industrial Access Road	13.9/14.4	0.70/0.72	B/B
US 41 at CR 676A (Madison Avenue/Pendola Point Road)	65.4/40.9	0.92/0.81	E/D
US 41 at Port Sutton Road	10.8/15.3	0.71/0.79	B/B
US 41 at Hartford Street* (unsignalized)	24.1/124.4	-	C/F

\*Unsignalized Intersection – Delay/LOS along worst minor approach.

Based on the existing analysis, with the exception of the intersections of US 41 at Florence Street, Nundy Avenue, CR 676A (Madison Avenue/Pendola Point Road) and Hartford Street, all the other study intersections operate at an acceptable level of service LOS D or better during both peak periods.

## **2.6 EXISTING YEAR (2013) ROADWAY SEGMENT ANALYSIS**

SYNCHRO Version 7.0 (Build 759) was used as the roadway segment analysis tool for US 41 between Kracker Avenue and south of SR 676 (Causeway Boulevard). The existing year (2013) roadway segment LOS analyses were conducted for US 41 using the estimated existing year (2013) AM and PM peak hour volumes. For the roadway segment analysis, the free flow speed was assumed to be the posted speed limit which varies between 40 mph and 55 mph within the project limits. The arterial class for US 41 was established to be Class I by SYNCHRO software. The existing roadway segment LOS results for the northbound and southbound directions of US 41 are summarized in **Table 2-3**. The roadway segment analysis SYNCHRO outputs are provided in **Appendix D**.

**Table 2-3 Existing Year (2013) AM/PM Roadway Segment Speed and Level of Service Summary**

Roadway	Segment	Existing Condition		
		Distance (mi)	Arterial Speed (mph)	Roadway Segment LOS
US 41 NB	Southern Project Limit to Symmes Road	2.03	42.1/46.2	A/A
	Symmes Road to Palm Avenue	0.42	25.0/27.9	D/C
	Palm Avenue to Gibsonton Drive/Alice Avenue	0.59	19.8/28.0	E/C
	Gibsonton Drive/Alice Avenue to Riverview Drive/Industrial Access Road	1.03	41.4/44.2	B/A
	Riverview Drive/Industrial Access Road to CR 676A (Madison Avenue/Pendola Point Road)	2.77	41.0/44.8	B/A
	CR 676A (Madison Avenue/Pendola Point Road) to Port Sutton Road	0.36	30.1/33.0	C/C
	Port Sutton Road to south of SR 676 (Causeway Boulevard)	1.16	31.3/34.4	C/B
US 41 SB	South of SR 676 (Causeway Boulevard) to Port Sutton Road	1.16	45.7/41.1	A/B
	Port Sutton Road to CR 676A (Madison Avenue/Pendola Point Road)	0.36	23.2/20.6	D/E
	CR 676A (Madison Avenue/Pendola Point Road) to Riverview Drive/Industrial Access Road	2.77	52.0/50.5	A/A
	Riverview Drive/Industrial Access Road to Gibsonton Drive/Alice Avenue	1.03	40.1/37.5	B/B
	Gibsonton Drive/Alice Avenue to Palm Avenue	0.59	46.0/43.7	A/A
	Palm Avenue to Symmes Road	0.42	32.4/34.2	C/B

Based on these results, the existing analysis shows that the section of US 41 between Palm Avenue and Gibsonton Drive/Alice Avenue does not operate at an acceptable level of service in the northbound direction during the AM peak period. In addition, the segment of US 41 between Port Sutton Road and CR 676A (Madison Avenue/Pendola Point Road) in the southbound direction does not operate at an acceptable level of service during the PM peak period.

**2.7 CRASH ANALYSIS**

Crash data along US 41 within the project limits was obtained from the Department for the five-year period of 2008 through 2012. There were a total of 551 crashes reported within the project limits during the five-year period which involved 408 injuries and 7 fatalities. **Table 2-4** below summarizes

the five-year crash history. As a part of the analysis, the number of crashes that occurred under wet conditions and the number of crashes that occurred at night were also summarized.

**Table 2-4 Summary of Crash Analysis along US 41**

US 41 from Kracker Avenue (MP 15.784) to south of Causeway Boulevard (MP 23.003) in Hillsborough County	Year					Five Year Total
	2008	2009	2010	2011	2012	
No. of Fatal Crashes	3	1	0	0	3	7
No. of Injury Crashes	46	43	55	58	50	252
No. of Property Damage Only Crashes	72	58	59	45	58	292
<b>Total Crashes</b>	<b>121</b>	<b>102</b>	<b>114</b>	<b>103</b>	<b>111</b>	<b>551</b>
Wet weather crashes	1	1	1	4	5	12
Night-time crashes	43	36	33	44	42	198
<i>Average Crash Rate with Average AADT of 27,250</i>						<i>1.54</i>
<i>Statewide Five-Year Average Crash Rate for Urban Segments*</i>						<i>2.39</i>
<i>Safety Ratio</i>						<i>0.64</i>

\*Obtained from FDOT District Seven

The table above shows that the average crash rate over the study corridor of US 41 is 1.54 which is lower compared to the statewide five-year average crash rate for 4-5 lanes two-way divided raised urban segments of 2.39.

The distribution of the crashes by mile post is shown in **Figure 2-4**. The plot indicates that the majority of the crashes occurred at the intersections of Symmes Road, Nundy Avenue, Gibsonton Drive/Alice Avenue, Riverview Drive/Industrial Access Road, CR 676A (Madison Avenue/Pendola Point Road) and Hartford Street.

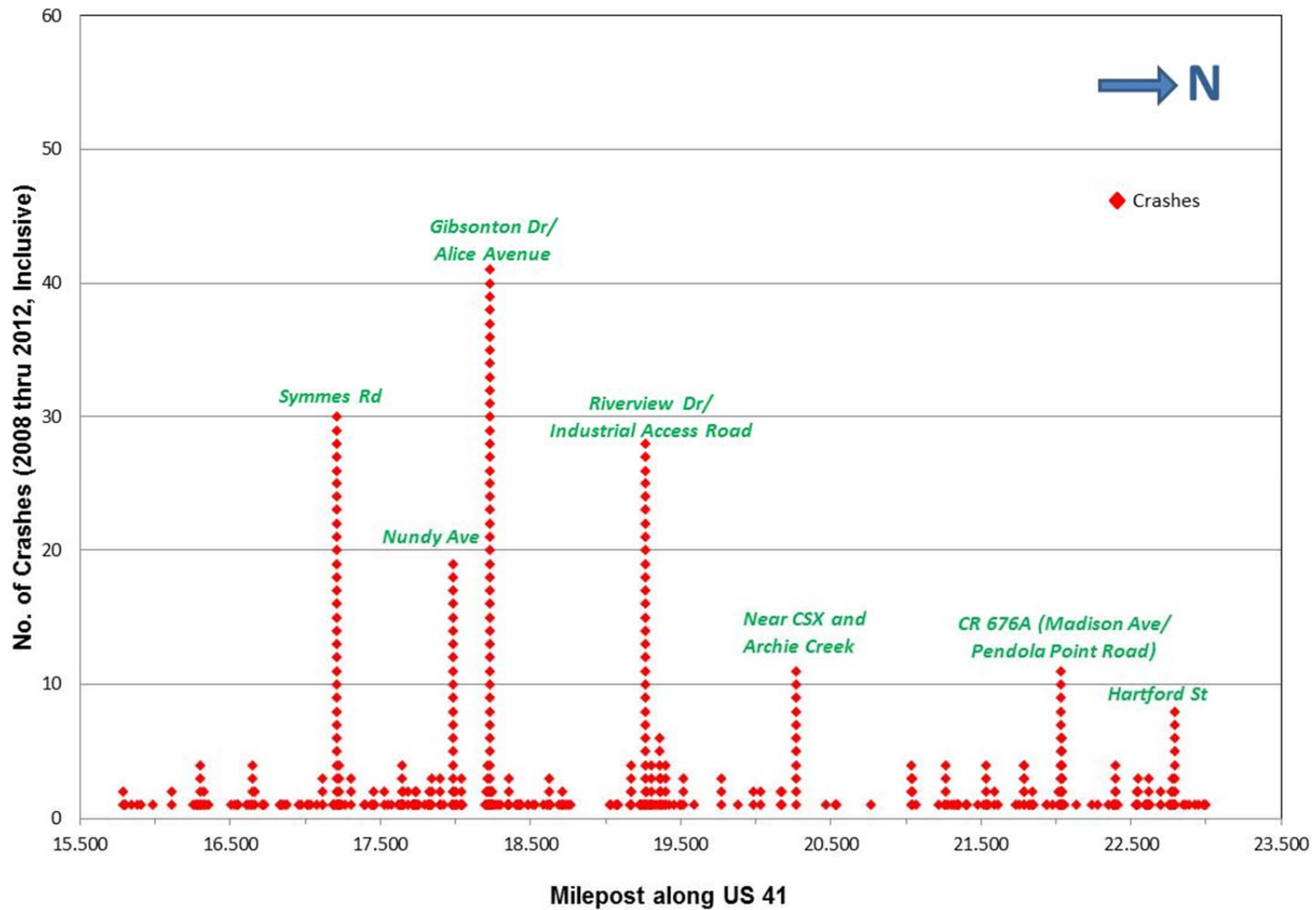
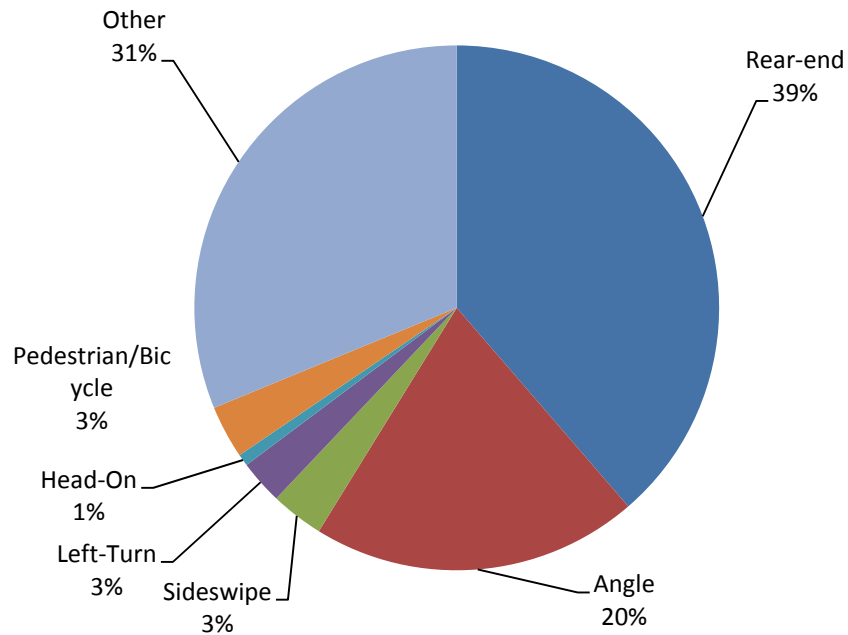

**Figure 2-4 Distribution of Crashes (2008-2012) by Milepost along US 41 from Kracker Avenue to South of SR 676 (Causeway Boulevard)**

The breakdown of the total crashes within the study limits for the same five-year period by crash type was also determined and is shown in **Table 2-5** and **Figure 2-5**. Overall, rear-end crashes accounted for 39 percent of the total crashes, angle crashes accounted for 20 percent, sideswipe and left-turn crashes each accounted for 3 percent and the remaining 35 percent of crashes were “other” crash types.

**Table 2-5 Summary of Crashes along US 41 by Crash Type**

Crash Type	Year					Total	Percentage	Average Per Year
	2008	2009	2010	2011	2012			
Rear-end	50	42	47	37	37	213	39%	42.6
Angle	21	24	23	20	23	111	20%	22.2
Sideswipe	7	5	6	0	0	18	3%	3.6
Left-Turn	7	4	3	0	1	15	3%	3.0
Head-On	3	0	0	1	0	4	1%	0.8
Pedestrian/Bicycle	6	0	0	4	8	18	3%	3.6
Other	27	27	35	41	42	172	31%	34.4
<b>Total</b>	<b>121</b>	<b>102</b>	<b>114</b>	<b>103</b>	<b>111</b>	<b>551</b>	<b>100%</b>	<b>110.2</b>



**Figure 2-5 Crashes Types along US 41 from Kracker Avenue to south of SR 676**

Sixteen (16) of the pedestrian/bicycle crashes occurred along US 41 between Kracker Avenue and Gibsonton Drive. Pedestrian and bicycle safety will be enhanced by providing sidewalks and bike lanes along the entire project corridor. Pedestrian crosswalks, pedestrian ramps, pedestrian signals will be provided per FDOT standards as a part of the design for the widening project. Also, crosswalks will be provided at all unsignalized intersections per FDOT standards. These will help to reduce pedestrian/bicycle crashes along the study corridor.



## SECTION 3 FUTURE TRAFFIC PROJECTIONS

Future year traffic volumes were developed using the Tampa Bay Regional Planning Model (TBRPM) Version 7.1. As indicated in the traffic methodology approved by FDOT District Seven in January 2013, only one set of future traffic volumes were developed that were used for both the no-build and the build conditions. The approved traffic methodology is included in **Appendix E**.

### 3.1 TRAVEL DEMAND MODEL

For the development of the future traffic volumes, Tampa Bay Regional Planning Model (TBRPM) version 7.1 was used. A base year (2006) model validation (reasonableness check) was performed for the study area along US 41 from Kracker Avenue to Causeway Boulevard. Adjustments were made to the base year model to improve the accuracy levels of the model volumes. Details on subarea validation are included as part of **Appendix B**. The process and results of subarea validation were coordinated with and approved by FDOT District Seven on April 8, 2013.

The subarea refinements included modifications to centroid connectors and facility types. These were applied to the future year 2035 model for the build scenario with six lanes along US 41 within project limits. Also, for the future year model, the 2035 socioeconomic (SE) data for the traffic analysis zones within the US 41 study area was compared to the SE data included in the socioeconomic analysis conducted by Renaissance Planning Group on behalf of the Tampa-Hillsborough County Expressway Authority (THEA). As the difference between the two data sets of the SE Data was not significant, no adjustments were made to the SE data for the adopted future year model. This was discussed with and agreed upon with FDOT District Seven on March 22, 2013. The documentation on SE data comparison is included as part of the subarea validation document included in **Appendix B**.

Based on the results of the subarea validation, it was suggested by FDOT District Seven that NCHRP 255 adjustment techniques (Ratio and Difference Method) be applied to the future year 2035 build model volumes along US 41 and along the following major side-streets: SR 676 (Causeway Boulevard), CR 676A (Madison Avenue/Pendola Point Road), Riverview Drive/Industrial Access Road, Gibsonton Drive/Alice Avenue, and Symmes Road. FDOT also recommended using a growth rate for the following minor side-streets: Hartford Street, Port Sutton Road, Nundy Avenue, Palm Avenue, Florence Street, Ohio Street and Kracker Avenue and along minor approaches of major side-streets. The NCHRP 255 method adjustments were applied to the 2035 build model volumes along US 41 and major side-streets within the project limits in order to establish the 2035 future model volumes to be used in forecasting along with the existing AADT. The NCHRP 255 adjustment and the model plots for the base year (2006) and future year (2035) are provided as a part of **Appendix B**. The growth rates for the minor side-streets and for the minor approaches of the major side-streets were based on the comparison of the socioeconomic data between the base year (2006) and future year (2035) for the traffic analysis zones adjacent to these individual side-streets. Based on this approach, an annual growth rate of 3.04% was recommended for the minor side-streets and an

annual growth rate of 1.81% was recommended for the minor approaches for the major side-streets. The calculations of these growth rates based on comparison of socioeconomic data and also, historical trend analyses have been included in **Appendix B**. The NCHRP 255 adjusted 2035 future build model volumes for US 41 and the major side-streets and the recommended growth rate for the minor side-streets and minor approaches of major side-streets were approved by FDOT District Seven on April 8, 2013 and May 16, 2013.

### **3.2 DEVELOPMENT OF FUTURE YEAR ANNUAL AVERAGE DAILY TRAFFIC (AADT) AND DESIGN HOUR TRAFFIC VOLUMES**

The opening year (2020), interim year (2030) and design year (2040) AADT were obtained by interpolation and extrapolation between the existing (2013) AADT and the established 2035 future build model volumes for the US 41 volumes and the major side-streets within the project limits. For the minor side-streets and the minor approaches of the major side-streets, future year AADT were calculated by applying a growth rate of 3.04% and 1.81% respectively on the existing (2013) AADT. The future year no-build and build AADT are shown in **Figure 3-1**.



The future year AM and PM peak hour directional traffic volumes (DDHV) were obtained by multiplying the future year AADT volumes by the recommended K and D factors, respectively. These estimated DDHVs were then distributed at the study intersections by applying the existing turning percentages from the existing traffic counts. As in the existing year (2013), southbound was considered to be the peak direction along US 41 within the project limits during the PM peak period and northbound was considered to be the peak direction during the AM peak period in the development of the peak hour turning volumes. Peak direction for each side-street was obtained from the existing traffic counts and is included as a part of **Appendix B**.

Calculation of the DDHV and the future AM and PM peak hour turning movements are provided as a part of **Appendix B**. The spreadsheets illustrating the development of the AM and PM peak hour traffic volumes for the opening year, interim year and design year are also included in Appendix B. The future no-build and build AM and PM peak hour volumes for the opening year (2020), interim year (2030) and design year (2040) are shown in **Figures 3-2, 3-3 and 3-4**, respectively.

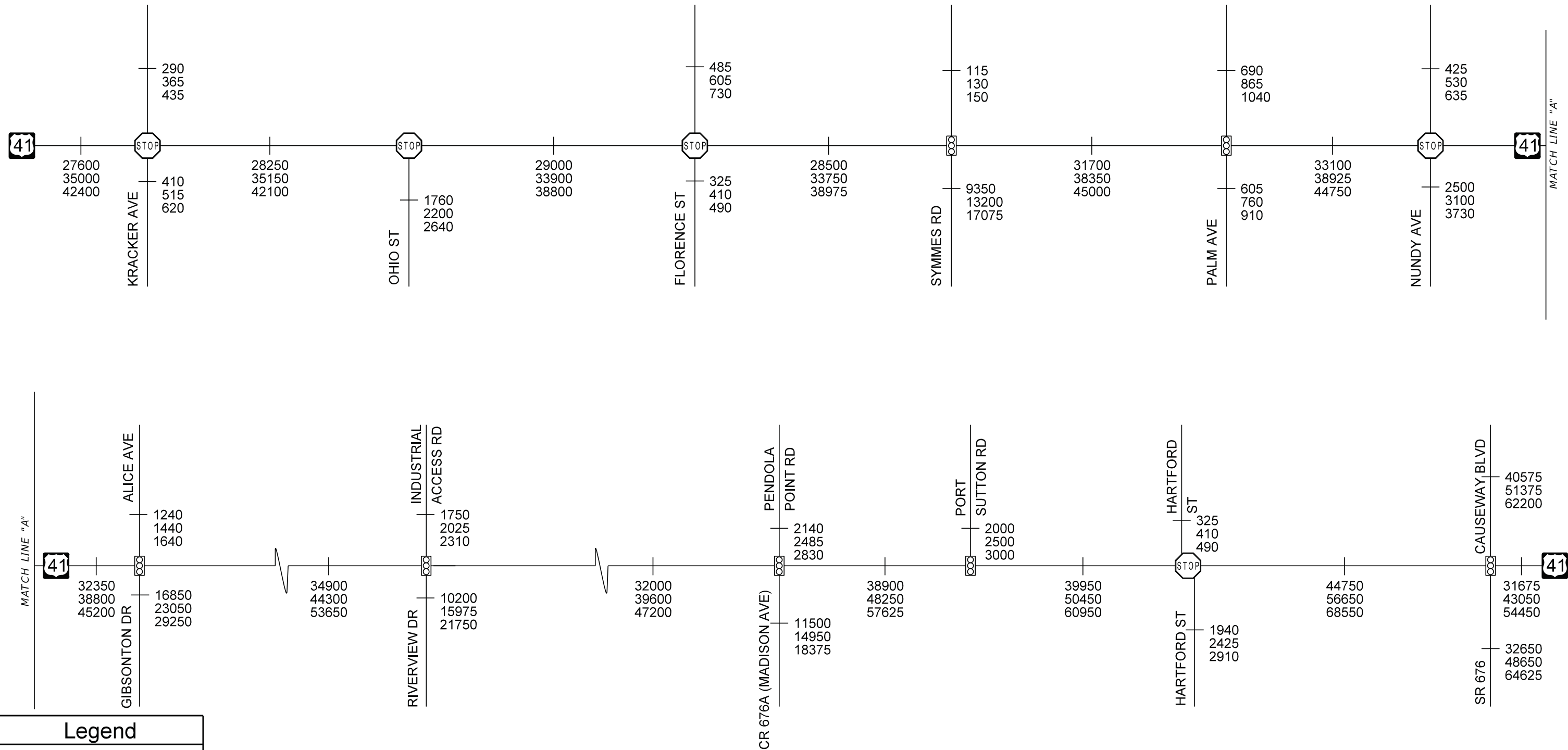
Future traffic volumes were reviewed and approved by FDOT District Seven on June 4, 2013 as a part of the memorandum on Recommended Design Hour Traffic Factors and Development of Existing and Future Traffic Volumes included in **Appendix B**.



**Legend**

-  TRAFFIC SIGNAL
-  STOP SIGN (SIDE STREET ONLY)



1234	2020 AADT
1234	2030 AADT
1234	2040 AADT

**US 41 PD&E Study**  
*From Kracker Avenue to South of SR 676 (Causeway Boulevard)*  
 WPI Number: 430056-1  
 Hillsborough County

**Future Year No-Build and Build Annual Average Daily Traffic (AADT)**

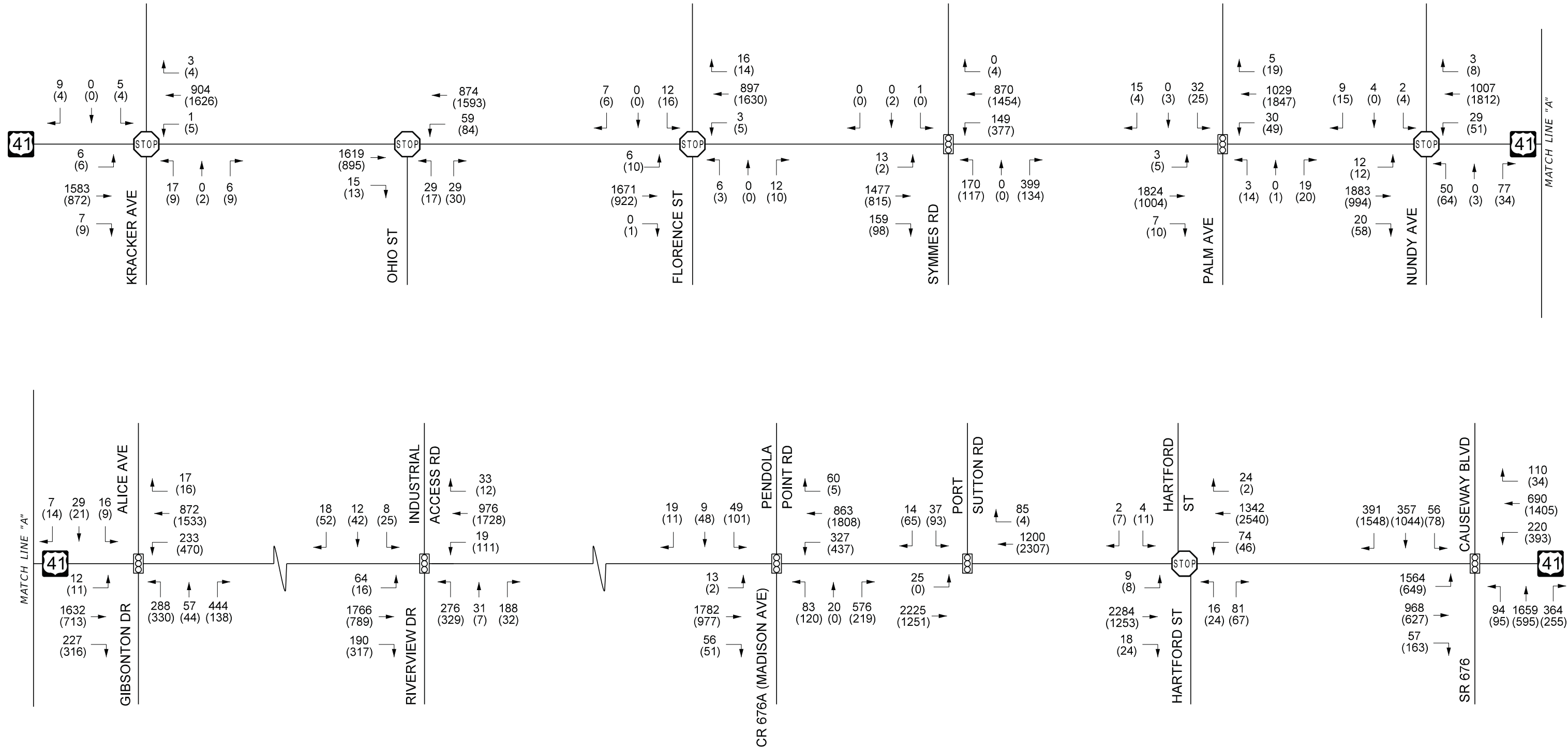
**Figure 3-1**





Legend	
	TRAFFIC SIGNAL
	STOP SIGN (SIDE STREET ONLY)
1234	AM PEAK HOUR VOLUME
(1234)	(PM PEAK HOUR VOLUME)

**US 41 PD&E Study**  
*From Kracker Avenue to South of SR 676 (Causeway Boulevard)*  
 WPI Number: 430056-1  
 Hillsborough County

Opening Year 2020 No-Build and Build AM and PM Peak Hour Traffic Volumes

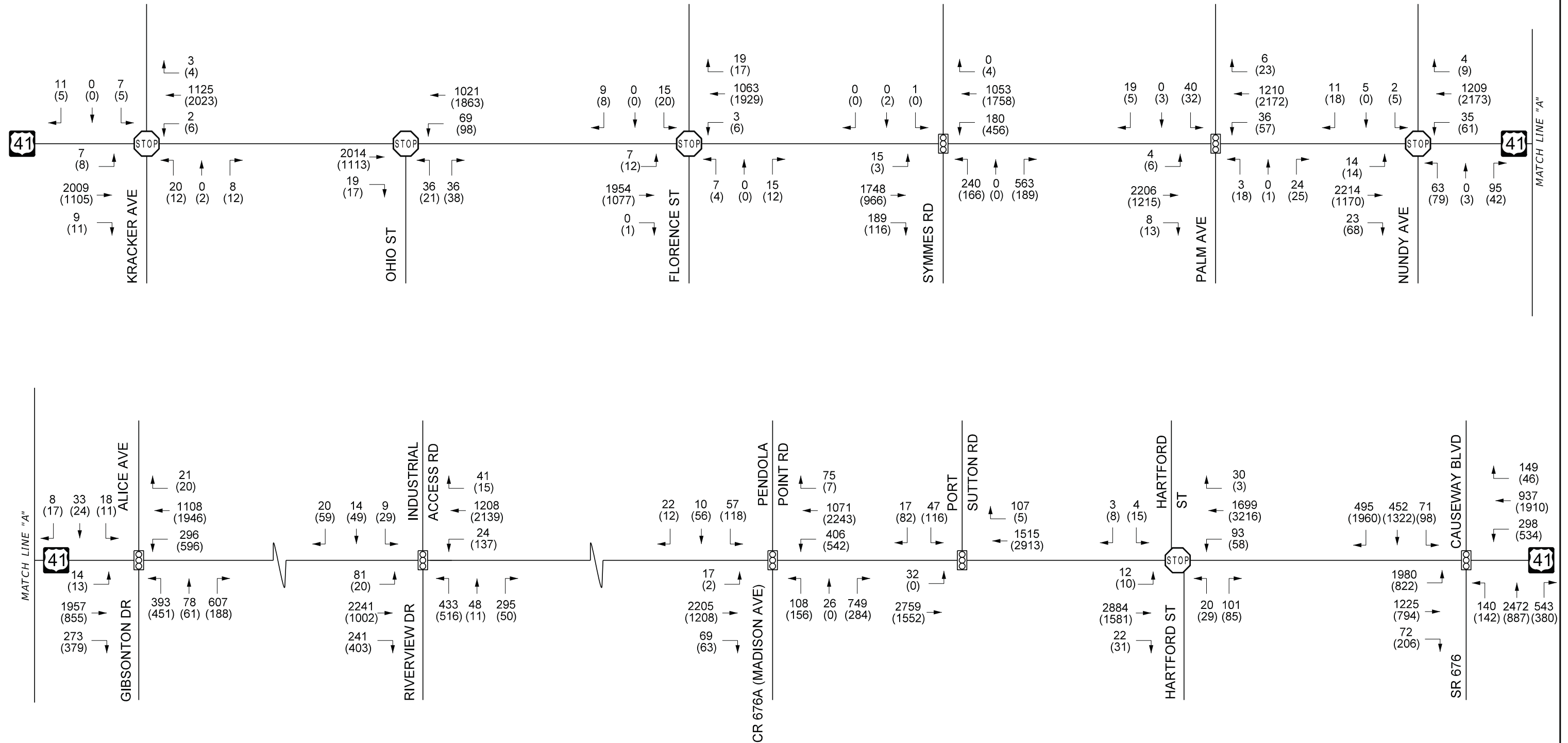
Figure 3-2





Legend	
	TRAFFIC SIGNAL
	STOP SIGN (SIDE STREET ONLY)
1234	AM PEAK HOUR VOLUME
(1234)	PM PEAK HOUR VOLUME

**US 41 PD&E Study**  
*From Kracker Avenue to South of SR 676 (Causeway Boulevard)*  
 WPI Number: 430056-1  
 Hillsborough County

Interim Year 2030 No-Build and Build AM and PM Peak Hour Traffic Volumes

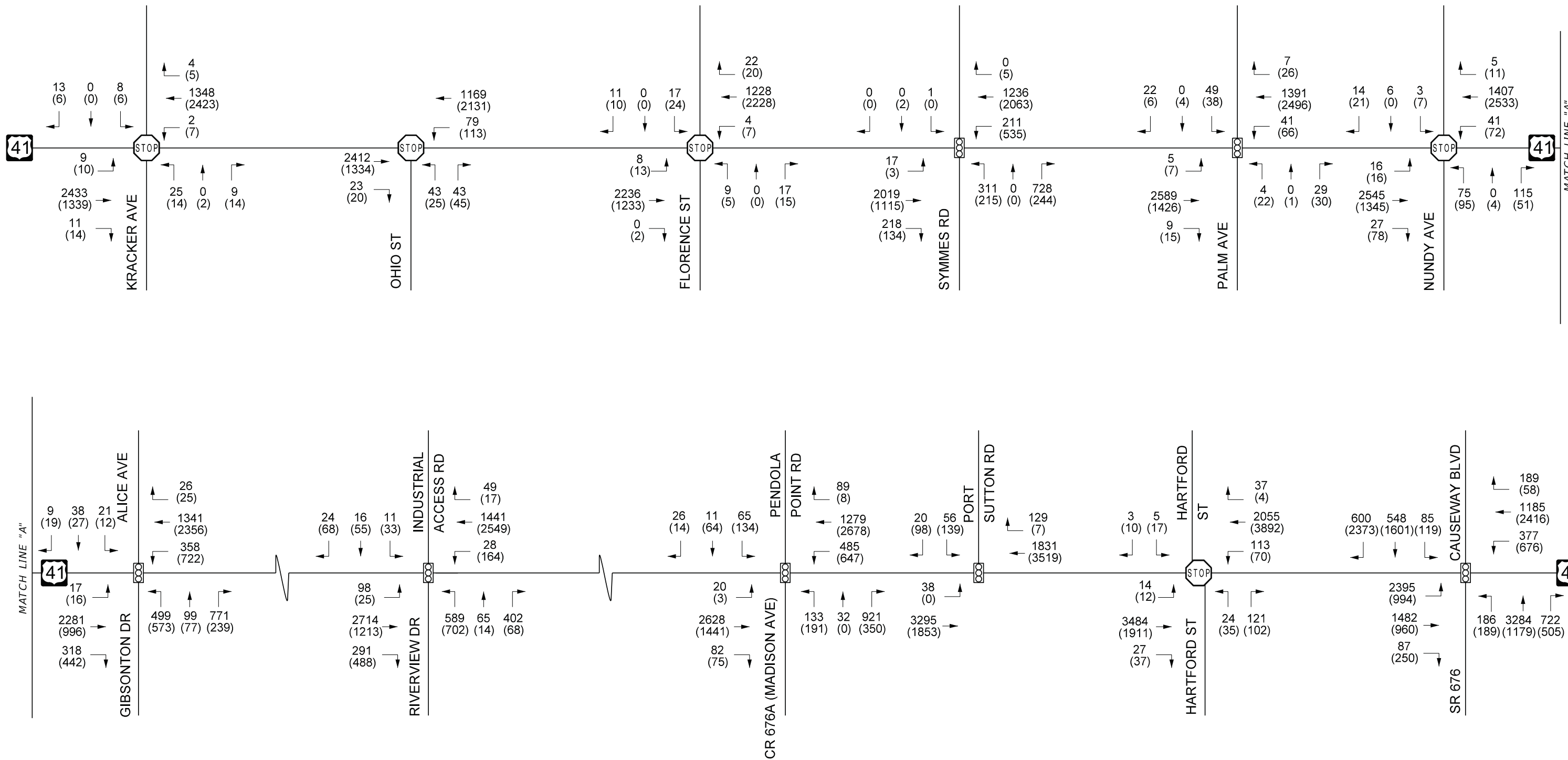
Figure 3-3



Legend	
	TRAFFIC SIGNAL
	STOP SIGN (SIDE STREET ONLY)
1234	AM PEAK HOUR VOLUME
(1234)	(PM PEAK HOUR VOLUME)

**US 41 PD&E Study**  
 From Kracker Avenue to South  
 of SR 676 (Causeway Boulevard)  
 WPI Number: 430056-1  
 Hillsborough County

Design Year 2040 No-Build and Build AM and PM Peak Hour Traffic Volumes

Figure 3-4

## SECTION 4 FUTURE OPERATIONAL ANALYSIS

All signalized, unsignalized intersections and roadway segments within the study area were evaluated for all the analysis years for both the AM and PM peak conditions under both the no-build and the build scenarios to estimate the future levels of service. The acceptable LOS standard is 'LOS D' for the study corridor of US 41 in the urbanized area from Kracker Avenue to south of SR 676 (Causeway Boulevard) based on the Planning Boundaries for LOS standards for Hillsborough County. SYNCHRO Version 7.0 (Build 759) was used as the analysis tool for the signalized intersections and segments within the study limits. Signalized intersection Level of Service (LOS) was estimated using the Highway Capacity Manual (HCM) module of the SYNCHRO Version 7.0 (Build 759) software. The Highway Capacity Software (HCS+) Version 5.5 was used for the unsignalized study intersections. SYNCHRO 7.0 was used as the roadway segment analysis tool for US 41 from Kracker Avenue to the south of SR 676 (Causeway Boulevard).

The following future years were evaluated in the future traffic operational analysis:

Opening Year	2020
Interim Year	2030
Design Year	2040

The future year's operational analysis was conducted for the No-Build and the Build conditions. The no-build condition considers the existing lane geometry shown in Figure 3-1. The build analysis considers US 41 to be widened to six lanes within the project limits. The proposed build typical section along US 41 within the study limits consists of a six-lane divided roadway with 50 mph design speed with the exception of the segment between Symmes Road and Riverview Drive/Industrial Access Road where the proposed design speed is 45 mph. This segment has a design speed of 45 mph as the transition to the urban section under the proposed typical section along US 41 occurs north of the Bullfrog Creek which is immediately north of Symmes Road. Also, the right of way is constrained along US 41 within this segment. North of Riverview Drive/Industrial Access Road, the right of way widens out and US 41 transitions back to a suburban section with higher design speed of 50 mph. Therefore, for the build analysis, a posted speed limit of 45 mph was used along US 41 within the project limits with the exception of the segment between Symmes Road and Riverview Drive/Industrial Access Road where a posted speed limit of 40 mph was used. The build analysis also considered additional improvements required for US 41 and the project intersections to operate at an acceptable level of service. The same traffic volumes were used for the no-build and the build analysis.

Also, in conducting the future traffic operational analysis, the potential for future signalization at unsignalized intersections was evaluated using a planning level analysis. Based on the analysis, it appeared that some unsignalized intersections may need future traffic signals. However, the need

for a traffic signal must be met by meeting specific traffic signal warrants as established within the Manual on Uniform Traffic Control Devices (MUTCD) and Manual on Uniform Traffic Studies (MUTS). The unsignalized intersection module of the Highway Capacity Software cannot analyze six lane roadways (three lanes per approach). In these cases, the unsignalized analysis was performed considering two through lanes on each approach and using two-thirds of the through traffic volume. This approach for the analysis of the unsignalized intersection with six lanes on the major roadway was agreed upon with FDOT staff.

#### **4.1 POTENTIAL FOR SIGNALIZATION AT THE UNSIGNALIZED STUDY INTERSECTIONS ALONG US 41**

Planning level evaluation of the signal warrants (Warrant 1 and Warrant 2 as included in the Manual on Uniform Traffic Studies (MUTS)) was conducted at the unsignalized locations – Kracker Avenue, Ohio Street, Florence Street, Nundy Avenue and Hartford Street along US 41 within the project limits. Warrants were evaluated using the two peak hour – AM and PM volumes available for the future years. Consideration was also given to access management for spacing in this analysis for determining if a signal is needed at these unsignalized locations. US 41 within the project limits is classified as Access Class 3 as obtained from 2012 Florida Transportation Information (FTI) DVD. For Access Class 3 controlled access facilities, standard signal spacing is 2640 feet (0.5 mile). Table 5-1 below summarizes the findings of this planning level analysis.



**Table 4-1 Planning Level Signal Warrant Evaluation at Unsignalized Intersections**

Unsignalized Intersection	Signal Warrant*	Opening Year 2020	Interim Year 2030	Design Year 2040	Recommendation
US 41 @ Kracker Avenue	1	Not Satisfied	Not Satisfied	Not Satisfied	Traffic Signal not recommended due to low traffic volumes.
	2	Not Satisfied	Not Satisfied	Not Satisfied	
US 41 @ Ohio Street	1	Not Satisfied	Not Satisfied	Not Satisfied	Traffic Signal not recommended due to low traffic volumes.
	2	Not Satisfied	Not Satisfied	Not Satisfied	
US 41 @ Florence Street	1	Not Satisfied	Not Satisfied	Not Satisfied	Traffic Signal not recommended due to low traffic volumes. Also, Access Management Signal Spacing requirement of 2640 feet not available.
	2	Not Satisfied	Not Satisfied	Not Satisfied	
US 41 @ Nundy Avenue	1	Not Satisfied	Not Satisfied	Not Satisfied	Traffic Signal not recommended. Also, Access Management Signal Spacing requirement of 2640 feet not available.
	2	Not Satisfied	Not Satisfied	Not Satisfied	
US 41 @ Hartford Street	1	Not Satisfied	Not Satisfied	Not Satisfied	Traffic Signal not recommended due to low traffic volumes. Also, Access Management Signal Spacing requirement of 2640 feet not available.
	2	Not Satisfied	Not Satisfied	Not Satisfied	

\*Only AM and PM peak hours.

Exclusive right-turn lanes were considered as a part of the future lane geometry for the westbound approach at unsignalized locations of Ohio Street, Nundy Avenue and Hartford Street. This allows the considerably higher volume westbound right-turns at these intersections to experience lesser delays.

Based on the planning level evaluation of signal warrant 1 and 2, none of the unsignalized intersections along US 41 within the project limits were warranted for the installation of a traffic signal.

However, in the future, complete signal warrant analysis should be performed at each of these unsignalized locations along US 41 within the project limits to evaluate if a traffic signal should be installed.

#### 4.2 DESIGN YEAR (2040) NO-BUILD LEVEL OF SERVICE ANALYSIS

The 2040 no-build condition includes the existing geometry shown in **Figure 3-1**. Levels of service (LOS) for the study intersections and roadway segments were calculated using the design hour volumes shown in **Figure 4-4**. The 2040 no-build calculated LOS for signalized and unsignalized intersections and the US 41 roadway segment within the project limits are summarized in **Tables 4-2** and **4-3**. Signal timings were optimized as a part of the future year analysis. The design year no-build LOS analysis details (SYNCHRO and HCS intersection analysis worksheets) are provided in **Appendix F**.

**Table 4-2 Design Year (2040) No-Build AM/PM Intersection Delay and Level of Service Summary**

Intersection	Overall Average Delay (seconds/vehicle)	Overall Intersection V/C Ratio	Overall Intersection LOS
US 41 at Kracker Avenue* (unsignalized)	358.6/116.4	-	F/F
US 41 at Ohio Street* (unsignalized)	596.3/39.5	-	F/E
US 41 at Florence Street* (unsignalized)	80.9/246.5	-	F/F
US 41 at Symmes Road	157.9/47.0	1.71/0.99	F/D
US 41 at Palm Avenue	61.0/26.7	1.07/0.91	E/C
US 41 at Nundy Avenue* (unsignalized)	- <sup>(1)</sup> / <sub>-<sup>(1)</sup></sub>	-	F/F
US 41 at Gibsonton Drive/Alice Avenue	178.2/150.9	1.59/1.45	F/F
US 41 at Riverview Drive/Industrial Access Road	170.2/153.2	1.49/1.52	F/F
US 41 at CR 676A (Madison Avenue/Pendola Point Road)	205.9/161.1	1.51/1.34	F/F
US 41 at Port Sutton Road	116.4/174.9	1.24/1.44	F/F
US 41 at Hartford Street* (unsignalized)	- <sup>(1)</sup> /901.2	-	F/F

\*Unsignalized Intersection – Delay/LOS along worst minor approach.

(1) Delay exceeds software capacity.

Based on the 2040 no-build intersection analysis, all the study intersections would fail to operate at an acceptable level of service during one or both peak periods.

**Table 4-3 Design Year (2040) No-Build AM/PM Roadway Segment Speed and Level of Service Summary**

Roadway	Segment	No-Build Condition		
		Distance (mi)	Arterial Speed (mph)	Roadway Segment LOS
US 41 NB	Southern Project Limit to Symmes Road	2.03	26.0/37.7	D/B
	Symmes Road to Palm Avenue	0.42	11.2/18.5	F/E
	Palm Avenue to Gibsonton Drive/Alice Avenue	0.59	9.3/13.7	F/F
	Gibsonton Drive/Alice Avenue to Riverview Drive/Industrial Access Road	1.03	11.4/40.4	F/B
	Riverview Drive/Industrial Access Road to CR 676A (Madison Avenue/Pendola Point Road)	2.77	21.5/40.9	D/B
	CR 676A (Madison Avenue/Pendola Point Road) to Port Sutton Road	0.36	6.5/27.4	F/C
	Port Sutton Road to south of SR 676 (Causeway Boulevard)	1.16	15.3/14.8	F/F
US 41 SB	South of SR 676 (Causeway Boulevard) to Port Sutton Road	1.16	42.1/11.6	A/F
	Port Sutton Road to CR 676A (Madison Avenue/Pendola Point Road)	0.36	22.1/6.3	D/F
	CR 676A (Madison Avenue/Pendola Point Road) to Riverview Drive/Industrial Access Road	2.77	47.2/31.2	A/C
	Riverview Drive/Industrial Access Road to Gibsonton Drive/Alice Avenue	1.03	40.5/18.1	B/E
	Gibsonton Drive/Alice Avenue to Palm Avenue	0.59	44.2/33.3	A/C
	Palm Avenue to Symmes Road	0.42	28.1/25.0	C/D

Based on the 2040 no-build roadway segment analysis, US 41 would fail to operate at an acceptable level of service in the northbound direction during one or both peak periods between Symmes Road and Riverview Drive/Industrial Access Road and between CR 676A (Madison Avenue/Pendola Point Road) and south of SR 676 (Causeway Boulevard). In the southbound direction, US 41 would fail to operate at an acceptable level of service during the PM peak between south of SR 676 (Causeway Boulevard) and CR 676A (Madison Avenue/Pendola Point Road) and between Riverview Drive/Industrial Access Road and Gibsonton Drive/Alice Avenue.

#### **4.3 DESIGN YEAR (2040) BUILD LEVEL OF SERVICE ANALYSIS**

The 2040 build initially proposed geometry is shown in **Figure 4-1**. This included the six laning of US 41 with improvements at the major intersections. The levels of service (LOS) for the study intersections and roadway segments were calculated using the design hour volumes shown in **Figure 4-4**. The 2040 build calculated LOS for signalized and unsignalized intersections and the US 41

roadway segment within the project limits are summarized in **Tables 4-4** and **4-5**. The design year build LOS analysis details (SYNCHRO and HCS intersection analysis worksheets) are also provided in **Appendix F**.

**Table 4-4 Design Year (2040) Build AM/PM Intersection Delay and LOS Summary**

Intersection	Overall Average Delay (seconds/vehicle)	Overall Intersection V/C Ratio	Overall Intersection LOS	With No-Build on Side Streets
US 41 at Kracker Avenue* (unsignalized)	58.9/35.4	-	F/E	--
US 41 at Ohio Street* (unsignalized)	51.8/18.7	-	F/C	--
US 41 at Florence Street* (unsignalized)	27.3/47.4	-	D/E	--
US 41 at Symmes Road	38.1/24.2	1.07/0.75	D/C	F/D
US 41 at Palm Avenue	16.7/16.2	0.75/0.73	B/B	--
US 41 at Nundy Avenue* (unsignalized)	144.3/28.3	-	F/D	--
US 41 at Gibsonton Drive/Alice Avenue	50.0/48.8	0.89/0.91	D/D	F/F
US 41 at Riverview Drive/Industrial Access Road	50.7/42.1	1.01/0.93	D/D	F/F
US 41 at CR 676A (Madison Avenue/Pendola Point Road)	54.8/37.7	1.02/0.90	D/D	E/D
US 41 at Port Sutton Road	19.5/33.9	0.91/1.04	B/C	--



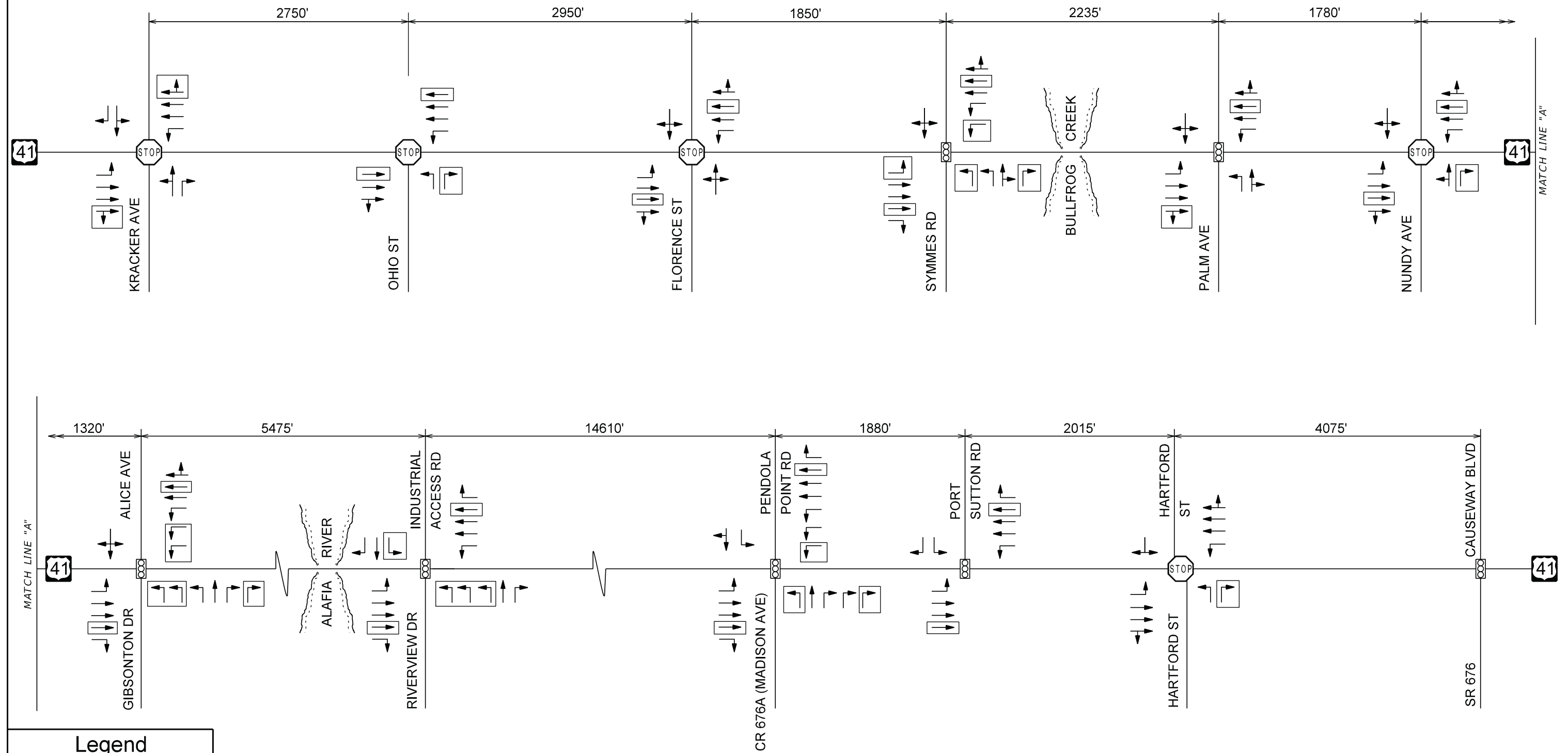

\*Unsignalized Intersection – Delay/LOS along worst minor approach.

\*\*Unsignalized Intersection – Side street approaches will be right turns only due to access management changes.

Based on the results of the 2040 build intersection analysis shown in the table above, all intersections would operate at an acceptable level of service except the minor approaches of the unsignalized intersections which would not operate at an acceptable level of service during AM peak or PM peak or both. Without the side-street improvements shown in **Figure 4-1**, most of the major intersections would experience LOS E or F in at least one peak period, as shown in the last column of **Table 4-4**.



**Legend**

-  TRAFFIC SIGNAL
-  STOP SIGN (SIDE STREET ONLY)
-  LANES
-  DISTANCE IN FEET
-  PROPOSED ADDITIONAL LANES

NOTE:  
 NOT ALL SIDE STREETS ARE SHOWN,  
 ONLY INTERSECTIONS ANALYZED ARE SHOWN.

NOTE:  
 US 41 AT CAUSEWAY BOULEVARD HAS BEEN EVALUATED  
 FOR GRADE SEPARATION UNDER FPID: 255599-1-32-02:  
 TRAFFIC OPERATIONS ANALYSIS FOR SR 676 (CAUSEWAY  
 BOULEVARD) FROM SR 45 (US 41) TO SR 43 (US 301)

**US 41 PD&E Study**  
*From Kracker Avenue to South  
 of SR 676 (Causeway Boulevard)*  
 WPI Number: 430056-1  
 Hillsborough County

Design Year (2040) Build Lane Geometry Required for Acceptable LOS

Figure 4-1

**Table 4-5 Design Year (2040) Build AM/PM Roadway Segment Speed and Level of Service Summary**

Roadway	Segment	Build Condition		
		Distance (mi)	Arterial Speed (mph)	Roadway Segment LOS
US 41 NB	Southern Project Limit to Symmes Road	2.03	36.2/38.9	A/A
	Symmes Road to Palm Avenue	0.42	25.7/29.1	C/B
	Palm Avenue to Gibsonton Drive/Alice Avenue	0.59	18.9/22.1	D/C
	Gibsonton Drive/Alice Avenue to Riverview Drive/Industrial Access Road	1.03	26.3/30.1	C/B
	Riverview Drive/Industrial Access Road to CR 676A (Madison Avenue/Pendola Point Road)	2.77	35.6/38.7	A/A
	CR 676A (Madison Avenue/Pendola Point Road) to Port Sutton Road	0.36	23.7/31.4	C/B
US 41 SB	Northern Project Limit to Port Sutton Road	1.16	40.0/29.3	A/B
	Port Sutton Road to CR 676A (Madison Avenue/Pendola Point Road)	0.36	26.7/21.6	C/D
	CR 676A (Madison Avenue/Pendola Point Road) to Riverview Drive/Industrial Access Road	2.77	39.8/38.3	A/A
	Riverview Drive/Industrial Access Road to Gibsonton Drive/Alice Avenue	1.03	33.1/28.5	B/B
	Gibsonton Drive/Alice Avenue to Palm Avenue	0.59	32.8/28.9	B/B
	Palm Avenue to Symmes Road	0.42	27.7/28.5	C/B

Based on the results of the 2040 build roadway segment analysis, all the segments along US 41 would operate at an acceptable level of service during both peak periods in both the northbound and the southbound directions if the improvements shown in **Figure 4-1** were made.

**Figure 4-1** shows the proposed 2040 build geometry along US 41 with the intersection improvements that are needed to operate at an acceptable level of service “D” with the triple left and right turn lanes along US 41 and the side-streets. Triple left turn lanes were initially recommended along the westbound and southbound approach at Gibsonton Drive/Alice Avenue, westbound approach at Riverview Drive/Industrial Access Road and southbound approach at CR 676A (Madison Avenue/Pendola Point Road). Triple right turn lanes were recommended along the westbound approach at CR 676A (Madison Avenue/Pendola Point Road). Based on the comments received from FDOT on August 14, 2013, additional analysis with dual left or dual right turn lanes at the previously mentioned intersections was conducted and is included in **Appendix F**. The analysis

indicated that these intersections would not operate at an acceptable level of service “D” with dual left and right turn lanes.

Additional analysis was also performed at the intersections of US 41 at Symmes Road, Gibsonton Drive/Alice Avenue, Riverview Drive/Industrial Access Road and CR 676A (Madison Avenue/Pendola Point Road) with no-build conditions along side-streets with six laning of US 41. This was based on the meeting with Hillsborough County on October 31, 2013 as the County does not have any plans for widening the side-streets with the exception of CR 676A (Madison Avenue/Pendola Point Road). Hillsborough County MPO’s 2035 Highway Needs Plan shows widening of CR 676A (Madison Avenue/Pendola Point Road) to four lanes. The work-sheets for this additional analysis are also included in **Appendix F**. The planned intersection improvements (as presented at the public hearing held in January 2016) are shown in **Figure 4-2**.

#### 4.4 INTERIM YEAR (2030) NO-BUILD LEVEL OF SERVICE ANALYSIS

The 2030 no-build condition includes the existing geometry shown in **Figure 2-1**. The levels of service (LOS) for the study intersections and roadway segments were calculated using the design hour volumes shown in **Figure 3-3**. The 2030 no-build calculated LOS for signalized and unsignalized intersections and the US 41 roadway segment within the project limits are summarized in **Tables 4-6** and **4-7**. Signal timings were optimized as a part of the future year analysis. The interim year no-build LOS analysis details (SYNCHRO and HCS intersection analysis worksheets) are provided in **Appendix G**.

**Table 4-6 Interim Year (2030) No-Build AM/PM Intersection Delay and Level of Service Summary**



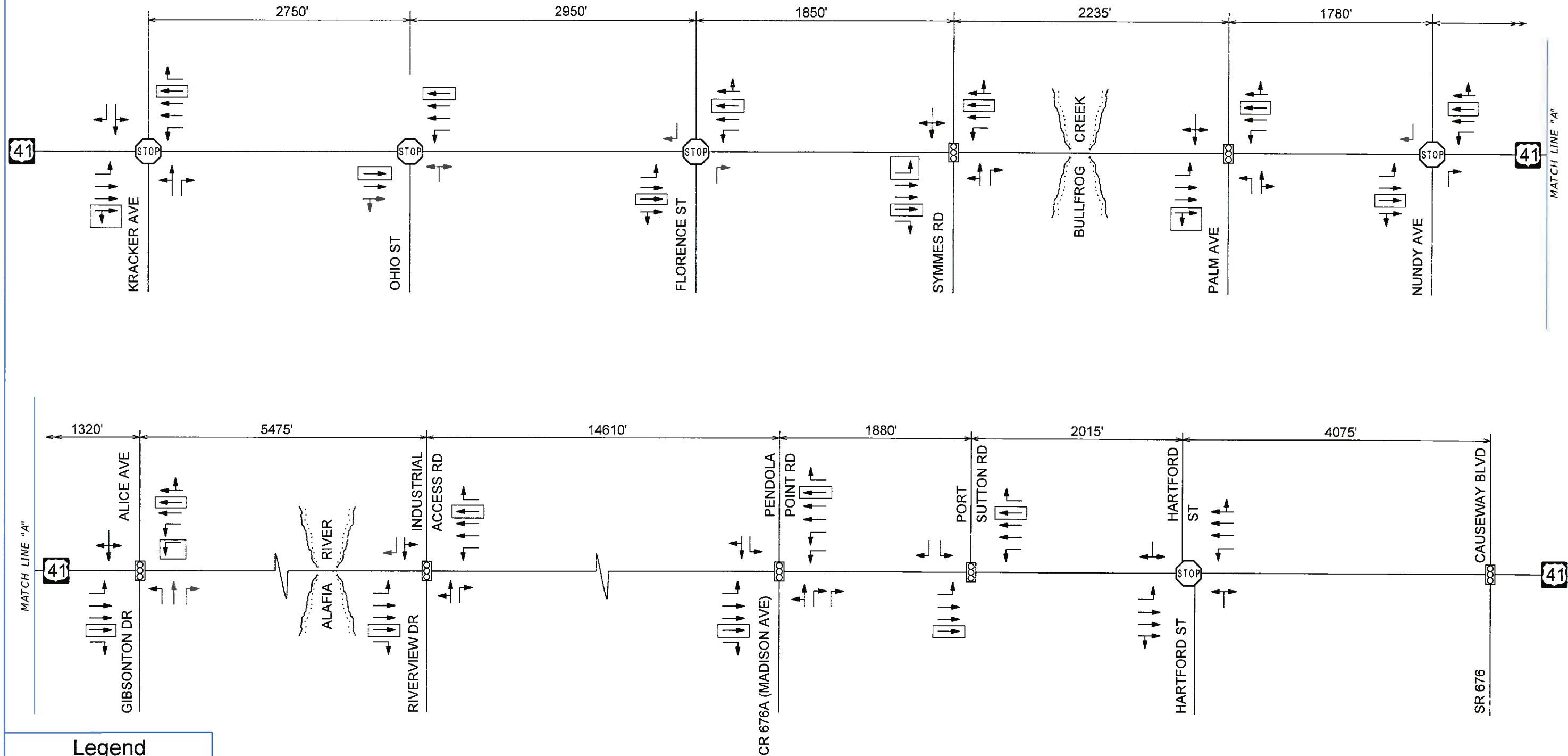

Intersection	Overall Average Delay (seconds/vehicle)	Overall Intersection V/C Ratio	Overall Intersection LOS
US 41 at Kracker Avenue* (unsignalized)	114.8/60.2	-	F/F
US 41 at Ohio Street* (unsignalized)	158.1/26.0	-	F/D
US 41 at Florence Street* (unsignalized)	45.3/101.3	-	E/F
US 41 at Symmes Road	91.4/27.8	1.53/0.90	F/C
US 41 at Palm Avenue	21.5/16.0	0.91/0.79	C/B
US 41 at Nundy Avenue* (unsignalized)	1016.0/150.1	-	F/F
US 41 at Gibsonton Drive/Alice Avenue	136.5/80.3	2.22/1.24	F/F
US 41 at Riverview Drive/Industrial Access Road	67.9/73.7	1.17/1.20	E/E
US 41 at CR 676A (Madison Avenue/Pendola Point Road)	131.2/82.1	1.26/1.11	F/F
US 41 at Port Sutton Road	50.4/93.9	1.04/1.20	D/F
US 41 at Hartford Street* (unsignalized)	- <sup>(1)</sup> /221.4	-	F/F

\*Unsignalized Intersection – Delay/LOS along worst minor approach.

(1) Delay exceeds software capacity.



**Legend**

-  TRAFFIC SIGNAL
-  STOP SIGN (SIDE STREET ONLY)
-  LANES
-  DISTANCE IN FEET
-  PROPOSED ADDITIONAL LANES

NOTE:  
 NOT ALL SIDE STREETS ARE SHOWN,  
 ONLY INTERSECTIONS ANALYZED ARE SHOWN.

NOTE:  
 US 41 AT CAUSEWAY BOULEVARD HAS BEEN EVALUATED  
 FOR GRADE SEPARATION UNDER FPID: 255599-1-32-02:  
 TRAFFIC OPERATIONS ANALYSIS FOR SR 676 (CAUSEWAY  
 BOULEVARD) FROM SR 45 (US 41) TO SR 43 (US 301)

**US 41 PD&E Study**  
 From Kracker Avenue to South  
 of SR 676 (Causeway Boulevard)  
 WPI Number: 430056-1  
 Hillsborough County

**FDOT Approved Lane Geometry (Planned Improvements)**

**Figure 4-2**



Based on the 2030 no-build intersection analysis, all the study intersections with the exception of US 41 at Palm Avenue, fail to operate at an acceptable level of service during one or both peak periods.

**Table 4-7 Interim Year (2030) No-Build AM/PM Roadway Segment Speed and Level of Service Summary**

Roadway	Segment	No-Build Condition		
		Distance (mi)	Arterial Speed (mph)	Roadway Segment LOS
US 41 NB	Southern Project Limit to Symmes Road	2.03	37.0/43.4	B/A
	Symmes Road to Palm Avenue	0.42	21.2/21.7	D/D
	Palm Avenue to Gibsonton Drive/Alice Avenue	0.59	21.1/21.1	D/D
	Gibsonton Drive/Alice Avenue to Riverview Drive/Industrial Access Road	1.03	30.0/41.3	C/B
	Riverview Drive/Industrial Access Road to CR 676A (Madison Avenue/Pendola Point Road)	2.77	27.5/41.9	C/B
	CR 676A (Madison Avenue/Pendola Point Road) to Port Sutton Road	0.36	14.3/30.2	F/C
	Port Sutton Road to south of SR 676 (Causeway Boulevard)	1.16	22.4/18.8	D/E
US 41 SB	South of SR 676 (Causeway Boulevard) to Port Sutton Road	1.16	43.9/17.9	A/E
	Port Sutton Road to CR 676A (Madison Avenue/Pendola Point Road)	0.36	23.3/12.0	D/F
	CR 676A (Madison Avenue/Pendola Point Road) to Riverview Drive/Industrial Access Road	2.77	51.1/41.7	A/B
	Riverview Drive/Industrial Access Road to Gibsonton Drive/Alice Avenue	1.03	41.5/29.9	B/C
	Gibsonton Drive/Alice Avenue to Palm Avenue	0.59	45.1/40.1	A/B
	Palm Avenue to Symmes Road	0.42	29.7/29.7	C/C

Based on the 2030 no-build roadway segment analysis, US 41 fails to operate at an acceptable level of service in the northbound direction during the AM peak between CR 676A (Madison Avenue/Pendola Point Road) and Port Sutton Road and during the PM peak between Port Sutton Road and south of SR 676 (Causeway Boulevard). In the southbound direction, US 41 fails to operate at an acceptable level of service during the PM peak between south of SR 676 (Causeway Boulevard) and CR 676A (Madison Avenue/Pendola Point Road).

#### 4.5 INTERIM YEAR (2030) BUILD LEVEL OF SERVICE ANALYSIS

The levels of service (LOS) for the study intersections and roadway segments for the interim year 2030 were calculated using the design hour volumes shown in **Figure 3-3** and the design year build geometry shown in **Figure 4-1**. The 2030 build calculated LOS for signalized and unsignalized intersections and the US 41 roadway segment within the project limits are summarized in **Tables 4-8** and 4-9. The interim year build LOS analysis details (SYNCHRO and HCS intersection analysis worksheets) are also provided in **Appendix G**.

**Table 4-8 Interim Year (2030) Build AM/PM Intersection Delay and Level of Service Summary**

Intersection	Overall Average Delay (seconds/vehicle)	Overall Intersection V/C Ratio	Overall Intersection LOS
US 41 at Kracker Avenue* (unsignalized)	34.4/25.4	-	D/D
US 41 at Ohio Street* (unsignalized)	30.3/15.8	-	D/C
US 41 at Florence Street* (unsignalized)	20.9/33.1	-	C/D
US 41 at Symmes Road	27.9/21.6	0.94/0.68	C/C
US 41 at Palm Avenue	14.6/14.3	0.66/0.72	B/B
US 41 at Nundy Avenue* (unsignalized)	59.8/- <sup>(1)</sup>	-	F/F
US 41 at Gibsonton Drive/Alice Avenue	37.0/37.3	0.75/0.76	D/D
US 41 at Riverview Drive/Industrial Access Road	30.3/32.4	0.87/0.88	C/C
US 41 at CR 676A (Madison Avenue/Pendola Point Road)	37.4/33.4	0.84/0.91	D/C
US 41 at Port Sutton Road	15.6/21.4	0.82/0.93	B/C
US 41 at Hartford Street* (unsignalized)	- <sup>(1)</sup> /221.4	-	F/F

\*Unsignalized Intersection – Delay/LOS along worst minor approach.

(1) Delay exceeds software capacity.

Based on the results of the 2030 build intersection analysis shown in the table above, all the intersections are operating at an acceptable level of service except the minor approaches of the unsignalized intersections along US 41 at Nundy Avenue and Hartford Street.

**Table 4-9 Interim Year (2030) Build AM/PM Roadway Segment Speed and Level of Service Summary**

Roadway	Segment	Build Condition		
		Distance (mi)	Arterial Speed (mph)	Roadway Segment LOS
US 41 NB	Southern Project Limit to Symmes Road	2.03	38.4/39.5	A/A
	Symmes Road to Palm Avenue	0.42	26.9/30.1	C/B
	Palm Avenue to Gibsonton Drive/Alice Avenue	0.59	22.9/23.6	C/C
	Gibsonton Drive to Riverview Drive/Industrial Access Road	1.03	31.1/31.4	B/B
	Riverview Drive/Industrial Access Road to CR 676A (Madison Avenue/Pendola Point Road)	2.77	38.9/39.6	A/A
	CR 676A (Madison Avenue/Pendola Point Road) to Port Sutton Road	0.36	26.2/30.6	C/B
US 41 SB	Northern Project Limit to Port Sutton Road	1.16	40.2/34.5	A/B
	Port Sutton Road to CR 676A (Madison Avenue/Pendola Point Road)	0.36	27.0/22.3	C/C
	CR 676A (Madison Avenue/Pendola Point Road) to Riverview Drive/Industrial Access Road	2.77	40.9/39.5	A/A
	Riverview Drive/Industrial Access Road to Gibsonton Drive/Alice Avenue	1.03	33.5/30.9	B/B
	Gibsonton Drive/Alice Avenue to Palm Avenue	0.59	32.5/29.7	B/B
	Palm Avenue to Symmes Road	0.42	29.1/28.9	B/B

Based on the results of the 2030 build roadway segment analysis, all the segments along US 41 operate at an acceptable level of service during both peak periods in both the northbound and the southbound directions.

**4.6 OPENING YEAR (2020) NO-BUILD LEVEL OF SERVICE ANALYSIS**

The 2020 no-build condition includes the existing geometry shown in **Figure 2-1**. The levels of service (LOS) for the study intersections and roadway segments were calculated using the design hour volumes shown in **Figure 3-2**. The 2020 no-build calculated LOS for signalized and unsignalized intersections and the US 41 roadway segment within the project limits are summarized in **Tables 4-10** and **4-11**. Signal timings were optimized as a part of the future year analysis. The opening year no-build LOS analysis details (SYNCHRO and HCS intersection analysis worksheets) are provided in **Appendix H**.

**Table 4-10 Opening Year (2020) No-Build AM/PM Intersection Delay and Level of Service Summary**

Intersection	Overall Average Delay (seconds/vehicle)	Overall Intersection V/C Ratio	Overall Intersection LOS
US 41 at Kracker Avenue* (unsignalized)	47.6/34.4	-	E/D
US 41 at Ohio Street* (unsignalized)	50.3/19.0	-	F/C
US 41 at Florence Street* (unsignalized)	31.3/52.7	-	D/F
US 41 at Symmes Road	43.9/17.1	1.04/0.72	D/B
US 41 at Palm Avenue	11.7/13.2	0.76/0.69	B/B
US 41 at Nundy Avenue* (unsignalized)	325.6/43.5	-	F/E
US 41 at Gibsonton Drive/Alice Avenue	54.5/48.3	1.07/0.95	D/D
US 41 at Riverview Drive/Industrial Access Road	23.0/26.1	0.92/0.94	C/C
US 41 at CR 676A (Madison Avenue/Pendola Point Road)	59.8/47.5	0.93/0.90	E/D
US 41 at Port Sutton Road	19.5/39.2	0.87/1.01	B/D
US 41 at Hartford Street* (unsignalized)	42.5/64.5	-	E/F

\*Unsignalized Intersection – Delay/LOS along worst minor approach.

Based on the 2020 no-build intersection analysis, all the study intersections with the exception of US 41 at Symmes Road, Palm Avenue, Gibsonton Drive/Alice Avenue, Riverview Drive/Industrial Access Road and Port Sutton Road, fail to operate at an acceptable level of service during one or both peak periods.

**Table 4-11 Opening Year (2020) No-Build AM/PM Roadway Segment Speed and Level of Service Summary**

Roadway	Segment	No-Build Condition		
		Distance (mi)	Arterial Speed (mph)	Roadway Segment LOS
US 41 NB	Southern Project Limit to Symmes Road	2.03	40.2/45.6	B/A
	Symmes Road to Palm Avenue	0.42	26.6/22.8	D/D
	Palm Avenue to Gibsonton Drive/Alice Avenue	0.59	23.2/22.3	D/D
	Gibsonton Drive/Alice Avenue to Riverview Drive/Industrial Access Road	1.03	37.7/42.9	B/A
	Riverview Drive/Industrial Access Road to CR 676A (Madison Avenue/Pendola Point Road)	2.77	41.6/44.2	B/A
	CR 676A (Madison Avenue/Pendola Point Road) to Port Sutton Road	0.36	24.8/31.2	D/C
	Port Sutton Road to SR 676 (Causeway Boulevard)	1.16	27.0/22.6	C/D
US 41 SB	SR 676 (Causeway Boulevard) to Port Sutton Road	1.16	44.7/29.6	A/C
	Port Sutton Road to CR 676A (Madison Avenue/Pendola Point Road)	0.36	26.3/20.1	D/E
	CR 676A (Madison Avenue/Pendola Point Road) to Riverview Drive/Industrial Access Road	2.77	51.7/47.0	A/A
	Riverview Drive/Industrial Access Road to Gibsonton Drive/Alice Avenue	1.03	42.3/34.6	A/B
	Gibsonton Drive/Alice Avenue to Palm Avenue	0.59	45.9/42.3	A/A
	Palm Avenue to Symmes Road	0.42	29.8/32.5	C/C

Based on the results of the 2020 no-build roadway segment analysis, the segment of US 41 between Port Sutton Road and CR 676A (Madison Avenue/Pendola Point Road) fails to operate at an acceptable level of service during the PM peak period in the southbound direction.

#### **4.7 OPENING YEAR (2020) BUILD LEVEL OF SERVICE ANALYSIS**

The levels of service (LOS) for the study intersections and roadway segments for the opening year 2020 were calculated using the design hour volumes shown in **Figure 3-2** and the design year build geometry shown in **Figure 4-1**. The 2020 build calculated LOS for signalized and unsignalized intersections and the US 41 roadway segment within the project limits are summarized in **Tables 4-12** and **4-13**. The opening year build LOS analysis details (SYNCHRO and HCS intersection analysis worksheets) are also provided in **Appendix H**.

**Table 4-12 Opening Year (2020) Build AM/PM Intersection Delay and Level of Service Summary**

<b>Intersection</b>	<b>Overall Average Delay (seconds/vehicle)</b>	<b>Overall Intersection V/C Ratio</b>	<b>Overall Intersection LOS</b>
US 41 at Kracker Avenue* (unsignalized)	23.1/19.1	-	C/C
US 41 at Ohio Street* (unsignalized)	21.1/13.6	-	C/B
US 41 at Florence Street* (unsignalized)	17.6/24.4	-	C/C
US 41 at Symmes Road	20.9/18.8	0.81/0.61	C/B
US 41 at Palm Avenue	13.5/13.8	0.67/0.65	B/B
US 41 at Nundy Avenue* (unsignalized)	29.2/- <sup>(1)</sup>	-	D/F
US 41 at Gibsonton Drive/Alice Avenue	32.1/34.2	0.63/0.69	C/C
US 41 at Riverview Drive/Industrial Access Road	21.0/21.7	0.69/0.74	C/C
US 41 at CR 676A (Madison Avenue/Pendola Point Road)	34.7/25.8	0.94/0.77	C/C
US 41 at Port Sutton Road	12.2/14.4	0.71/0.81	B/B
US 41 at Hartford Street* (unsignalized)	34.7/64.5	-	D/F

\*Unsignalized Intersection – Delay/LOS along worst minor approach.

(1) Delay exceeds software capacity.

Based on the results of the 2020 build intersection analysis shown in the table above, the minor approaches of the unsignalized intersections along US 41 at Nundy Avenue and Hartford Street do not operate at an acceptable level of service during the PM peak.

**Table 4-13 Opening Year (2020) Build AM/PM Roadway Segment Speed and Level of Service Summary**

Roadway	Segment	Build Condition		
		Distance (mi)	Arterial Speed (mph)	Roadway Segment LOS
US 41 NB	Southern Project Limit to Symmes Road	2.03	39.5/40.5	A/A
	Symmes Road to Palm Avenue	0.42	28.4/30.0	B/B
	Palm Avenue to Gibsonton Drive	0.59	25.0/25.4	C/C
	Gibsonton Drive to Riverview Drive	1.03	34.0/33.1	B/B
	Riverview Drive to CR 676A (Madison Avenue)	2.77	38.0/39.9	A/A
	CR 676A (Madison Avenue) to Port Sutton Road	0.36	28.0/30.9	C/B
US 41 SB	Northern Project Limit to Port Sutton Road	1.16	40.4/37.6	A/A
	Port Sutton Road to CR 676A (Madison Avenue)	0.36	27.1/24.3	C/C
	CR 676A (Madison Avenue) to Riverview Drive	2.77	41.7/41.4	A/A
	Riverview Drive to Gibsonton Drive	1.03	34.1/32.0	B/B
	Gibsonton Drive to Palm Avenue	0.59	31.8/29.9	B/B
	Palm Avenue to Symmes Road	0.42	30.1/29.8	B/B

Based on the results of the 2020 build roadway segment analysis, all the segments along US 41 operate at an acceptable level of service during both peak periods in both the northbound and the southbound directions.

#### **4.8 INTERSECTION TURN LANE STORAGE LENGTHS**

The intersection storage lengths for the signalized intersections were calculated for the design year 2040 build conditions based on the ITE “red-time” formula. The recommended turn lane lengths were rounded to the nearest 25 feet increment and are shown in **Table 4-14**. At the intersections of Riverview Drive/Industrial Access Road, CR 676A (Madison Avenue/Pendola Point Road) and Port Sutton Road which provide direct access to the Port of Tampa, storage lane lengths were estimated using truck percentages from the special turning movement counts that were conducted during the hours when truck traffic was observed to be highest so that the proposed turn lane can accommodate the truck volumes. The detailed calculation for the queue lengths and the turn lane lengths are included in **Appendix I**.

Also, the left-turn lane and the right-turn storage lane lengths along US 41 at the unsignalized intersections were estimated for the 2040 build conditions based on *Figure 3-15 of the Manual of Uniform Minimum Standards for Design, Construction and Maintenance for Streets and Highways (Florida Greenbook), May 2011*. The recommended turn lane lengths were rounded to the nearest 25 feet increment and are shown in **Table 4-14** and these estimates are also included in **Appendix I**.

**Table 4-14 Design Year (2040) Preferred Turn Lane Storage Lengths**

US 41 Intersections	Approach	Movement	Preferred Turn Lane Length (feet)
Kracker Avenue* (un-signalized)	Northbound	Left	275
		Thru-Right	
	Southbound	Left	275
		Right	275
Ohio Street* (un-signalized)	Northbound	Thru-Right	
	Southbound	Left	350
Florence Street* (un-signalized)	Northbound	Left	275
		Thru-Right	
	Southbound	Left	275
		Thru-Right	
Symmes Road	Eastbound	Left-Thru-Right	
	Westbound	Left-Thru	400
		Right	
	Northbound	Left	1000 <sup>(1)</sup>
		Right	1000 <sup>(1)</sup>
	Southbound	Left	875
Thru-Right			
Palm Avenue	Eastbound	Left-Thru-Right	
	Westbound	Left	175
		Thru-Right	
	Northbound	Left	425 <sup>(1)</sup>
		Thru-Right	
	Southbound	Left	425 <sup>(1)</sup>
Thru-Right			
Nundy Avenue* (un-signalized)	Northbound	Left	225
		Thru-Right	
	Southbound	Left	300
		Thru-Right	



**Table 4-14 Design Year (2040) Preferred Turn Lane Storage Lengths (Cont'd)**

US 41 Intersections	Approach	Movement	Preferred Turn Lane Length (feet)
Gibsonton Drive/Alice Avenue	Eastbound	Left-Thru-Right	
		Left	1300
	Westbound	Right	1075
		Left	1050 <sup>(1)</sup>
	Northbound	Right	1050 <sup>(1)</sup>
		Left	900 <sup>(1)</sup>
Southbound	Thru-Right		
	Left-Thru		
Riverview Drive/Industrial Access Road	Eastbound	Right	275
		Left-Thru	
	Westbound	Right	1125 <sup>(1)</sup>
		Left	925 <sup>(1)</sup>
	Northbound	Right	925 <sup>(1)</sup>
		Left	900 <sup>(1)</sup>
	Southbound	Right	900 <sup>(1)</sup>
		Left	375
CR 676A (Madison Avenue/Pendola Point Road)	Eastbound	Thru-Right	
		Left-Thru	
	Westbound	Right	1050
		Left	950 <sup>(1)</sup>
	Northbound	Right	950 <sup>(1)</sup>
		Left	775 <sup>(1)</sup>
	Southbound	Right	600 <sup>(1)</sup>
		Left	550
Port Sutton Road	Eastbound	Right	425
		Left	850 <sup>(1)</sup>
	Northbound	Left	775 <sup>(1)</sup>
		Right	775 <sup>(1)</sup>

\* For un-signalized intersections, turn lane lengths along US 41 estimated from *Figure 3-15 Florida Green Book, May 2011*.

<sup>(1)</sup> Based on thru lane queue as thru lane queue exceeds storage length for turn lanes.

Table Revised July 2016

## SECTION 5 CONCLUSION

The operational analysis for the existing conditions showed that with the exception of the intersections of US 41 at Florence Street, Nundy Avenue, CR 676A (Madison Avenue/Pendola Point Road), Hartford Street and SR 676 (Causeway Boulevard), all the other study intersections operate at an acceptable level of service LOS D or better during both the peak periods. The existing roadway segment analysis showed that the section of US 41 between Palm Avenue and Gibsonton Drive/Alice Avenue does not operate at an acceptable level of service in the northbound direction during the AM peak period. And the segment of US 41 between Port Sutton Road and CR 676A (Madison Avenue/Pendola Point Road) in the southbound direction does not operate at an acceptable level of service during the PM peak period.

Operational analyses of future conditions for years 2040, 2030, and 2020 were conducted for both the no-build and the build conditions as a part of this study. The no-build condition considered the existing lane geometry. The analysis showed that the study intersections and the roadway segments deteriorated during the future years under the no-build conditions. The build condition considered widening US 41 to six lanes within the project limits. Operational analysis for build conditions showed that widening of US 41 to six lanes from Kracker Avenue to south of SR 676 (Causeway Boulevard) with minor improvements at certain intersections would result in improved traffic operation and reduced delay by 2040 along the US 41 roadway segments within the project limits and also, at the study intersections with intersection turn lane improvements. Pedestrian crosswalks, pedestrian ramps and pedestrian signals will be provided per FDOT standards as a part of the design for the widening project. Also, crosswalks will be provided at all unsignalized intersections per FDOT District Seven standards. Pedestrian and bicycle safety will be enhanced by providing sidewalks and bike lanes along the entire project corridor.

## List of Appendices

---

- Appendix A Existing Traffic Volumes
- Appendix B Memorandum on Recommended Design Hour Traffic Factors and Development of Existing and Future Traffic Volumes
- Appendix C Existing Signal Timings
- Appendix D Existing Year 2013 Level of Service
- Appendix E Traffic Methodology Statement
- Appendix F Design Year 2040 No-Build and Build Level of Service
- Appendix G Interim Year 2030 No-Build and Build Level of Service
- Appendix H Opening Year 2020 No-Build and Build Level of Service
- Appendix I Intersection Turn Lane Storage Lengths
- Appendix J Traffic Forms for Noise and Air Studies
- Appendix K FDOT Comment-Responses and Meeting Minutes

# Appendix A

## Existing Traffic Volumes

**RAW TURNING MOVEMENT COUNTS  
AND  
72-HOUR APPROACH COUNTS**



# Southern Traffic Services, Inc.

2911 Westfield Rd  
Gulf Breeze, FL 32563  
1-800-786-3374

*Traffic is our only business!*

US 41 @ Kracker Ave  
Tampa, FL

File Name : 13015-1 US 41 @ Kracker Ave  
Site Code : 13015-1  
Start Date : 1/10/2013  
Page No : 1

Groups Printed- Automobiles - Trucks - Buses

Start Time	US 41 Southbound				KRACKER AVE Westbound				US 41 Northbound				KRACKER AVE Eastbound				Int. Total
	Left	Thru	Right	U-Turns	Left	Thru	Right	U-Turns	Left	Thru	Right	U-Turns	Left	Thru	Right	U-Turns	
07:00 AM	0	150	0	0	4	0	0	0	1	315	2	0	0	0	2	0	474
07:15 AM	0	148	0	0	2	0	3	0	1	361	1	0	2	0	2	0	520
07:30 AM	0	181	1	1	1	0	0	0	2	370	1	0	1	0	1	0	559
07:45 AM	0	170	1	0	1	0	0	0	1	314	2	0	0	0	0	0	489
Total	0	649	2	1	8	0	3	0	5	1360	6	0	3	0	5	0	2042
08:00 AM	0	94	0	0	2	0	0	0	0	286	1	0	1	0	0	0	384
08:15 AM	1	120	1	0	2	0	0	0	1	223	2	0	2	0	0	0	352
08:30 AM	1	120	0	0	0	0	1	0	1	190	0	0	0	0	1	0	314
08:45 AM	2	69	0	0	2	0	1	0	0	171	1	0	0	0	0	0	246
Total	4	403	1	0	6	0	2	0	2	870	4	0	3	0	1	0	1296
<b>**BREAK**</b>																	
04:00 PM	3	289	0	0	0	0	0	0	2	188	3	1	0	0	1	0	487
04:15 PM	1	293	1	1	0	0	1	0	2	158	0	1	2	0	2	0	462
04:30 PM	2	304	1	0	2	0	0	0	0	181	0	0	1	0	0	0	491
04:45 PM	0	310	0	0	0	0	1	0	0	156	1	0	0	0	0	0	468
Total	6	1196	2	1	2	0	2	0	4	683	4	2	3	0	3	0	1908
05:00 PM	0	332	1	1	3	1	2	0	0	177	1	3	2	0	1	0	524
05:15 PM	1	361	1	0	3	0	2	0	1	170	1	1	0	0	1	0	542
05:30 PM	2	384	1	0	0	0	1	0	0	171	4	0	0	0	0	0	563
05:45 PM	0	300	1	0	2	0	1	0	0	137	3	2	0	0	0	0	446
Total	3	1377	4	1	8	1	6	0	1	655	9	6	2	0	2	0	2075
Grand Total	13	3625	9	3	24	1	13	0	12	3568	23	8	11	0	11	0	7321
Apprch %	0.4	99.3	0.2	0.1	63.2	2.6	34.2	0	0.3	98.8	0.6	0.2	50	0	50	0	
Total %	0.2	49.5	0.1	0	0.3	0	0.2	0	0.2	48.7	0.3	0.1	0.2	0	0.2	0	
Automobiles	11	3443	9	3	23	1	9	0	11	3412	21	8	10	0	11	0	6972
% Automobiles	84.6	95	100	100	95.8	100	69.2	0	91.7	95.6	91.3	100	90.9	0	100	0	95.2
Trucks	2	157	0	0	1	0	2	0	1	135	0	0	1	0	0	0	299
% Trucks	15.4	4.3	0	0	4.2	0	15.4	0	8.3	3.8	0	0	9.1	0	0	0	4.1
Buses	0	25	0	0	0	0	2	0	0	21	2	0	0	0	0	0	50
% Buses	0	0.7	0	0	0	0	15.4	0	0	0.6	8.7	0	0	0	0	0	0.7



# Southern Traffic Services, Inc.

2911 Westfield Rd  
 Gulf Breeze, FL 32563  
 1-800-786-3374

*Traffic is our only business!*

US 41 @ Kracker Ave  
 Tampa, FL

File Name : 13015-1 US 41 @ Kracker Ave  
 Site Code : 13015-1  
 Start Date : 1/10/2013  
 Page No : 2

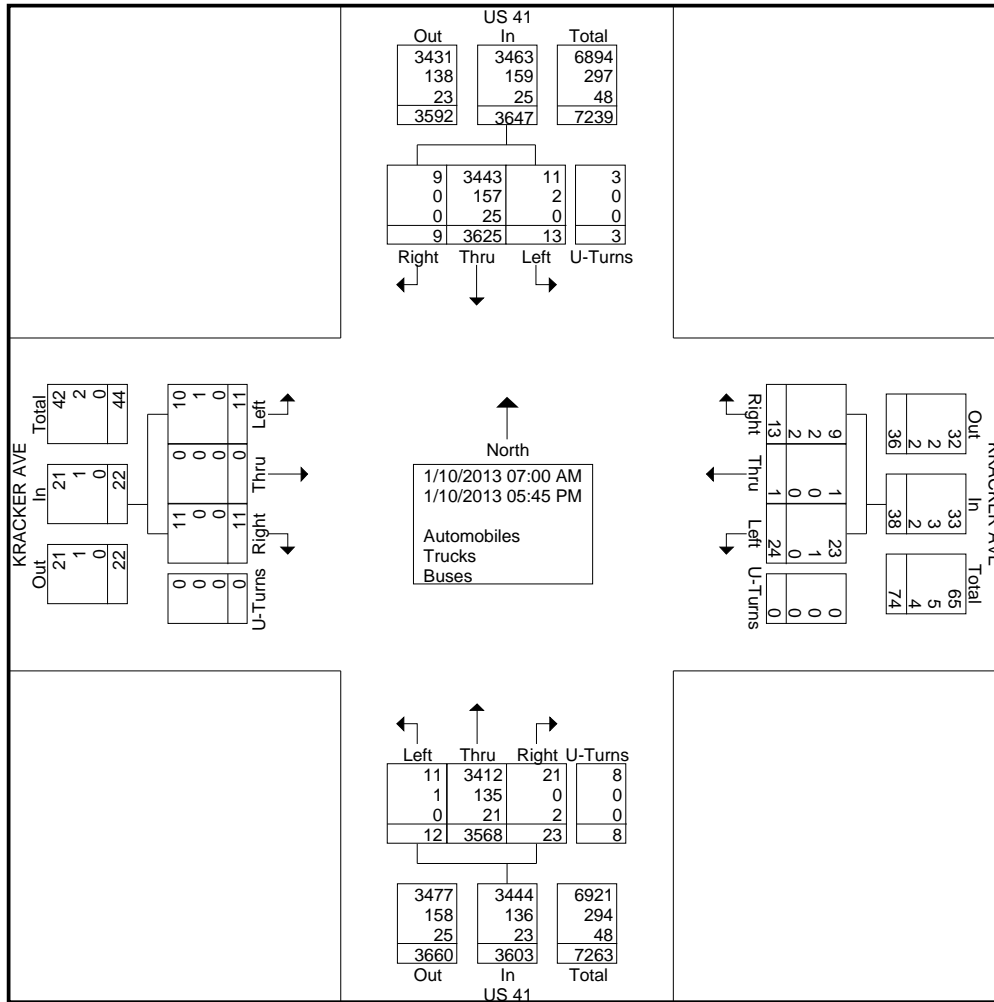



# Southern Traffic Services, Inc.

2911 Westfield Rd  
 Gulf Breeze, FL 32563  
 1-800-786-3374

*Traffic is our only business!*

US 41 @ Kracker Ave  
 Tampa, FL

File Name : 13015-1 US 41 @ Kracker Ave  
 Site Code : 13015-1  
 Start Date : 1/10/2013  
 Page No : 3

Start Time	US 41 Southbound				KRACKER AVE Westbound				US 41 Northbound				KRACKER AVE Eastbound				Int. Total				
	Thru	Right	U-Turns	App. Total	Left	Thru	Right	U-Turns	App. Total	Left	Thru	Right	U-Turns	App. Total	Left	Thru		Right	U-Turns	App. Total	
Peak Hour Analysis From 07:00 AM to 11:45 AM - Peak 1 of 1																					
Peak Hour for Entire Intersection Begins at 07:00 AM																					
07:00 AM	0	150	0	0	150	4	0	0	0	4	1	315	2	0	318	0	0	2	0	2	474
07:15 AM	0	148	0	0	148	2	0	3	0	5	1	361	1	0	363	2	0	2	0	4	520
07:30 AM	0	181	1	1	183	1	0	0	0	1	2	370	1	0	373	1	0	1	0	2	559
07:45 AM	0	170	1	0	171	1	0	0	0	1	1	314	2	0	317	0	0	0	0	0	489
Total Volume	0	649	2	1	652	8	0	3	0	11	5	1360	6	0	1371	3	0	5	0	8	2042
% App. Total	0	99.5	0.3	0.2		72.7	0	27.3	0		0.4	99.2	0.4	0		37.5	0	62.5	0		
PHF	.000	.896	.500	.250	.891	.500	.000	.250	.000	.550	.625	.919	.750	.000	.919	.375	.000	.625	.000	.500	.913
Automobiles	0	574	2	1	577	8	0	3	0	11	5	1335	4	0	1344	3	0	5	0	8	1940
% Automobiles	0	88.4	100	100	88.5	100	0	100	0	100	100	98.2	66.7	0	98.0	100	0	100	0	100	95.0
Trucks	0	67	0	0	67	0	0	0	0	0	0	19	0	0	19	0	0	0	0	0	86
% Trucks	0	10.3	0	0	10.3	0	0	0	0	0	0	1.4	0	0	1.4	0	0	0	0	0	4.2
Buses	0	8	0	0	8	0	0	0	0	0	0	6	2	0	8	0	0	0	0	0	16
% Buses	0	1.2	0	0	1.2	0	0	0	0	0	0	0.4	33.3	0	0.6	0	0	0	0	0	0.8

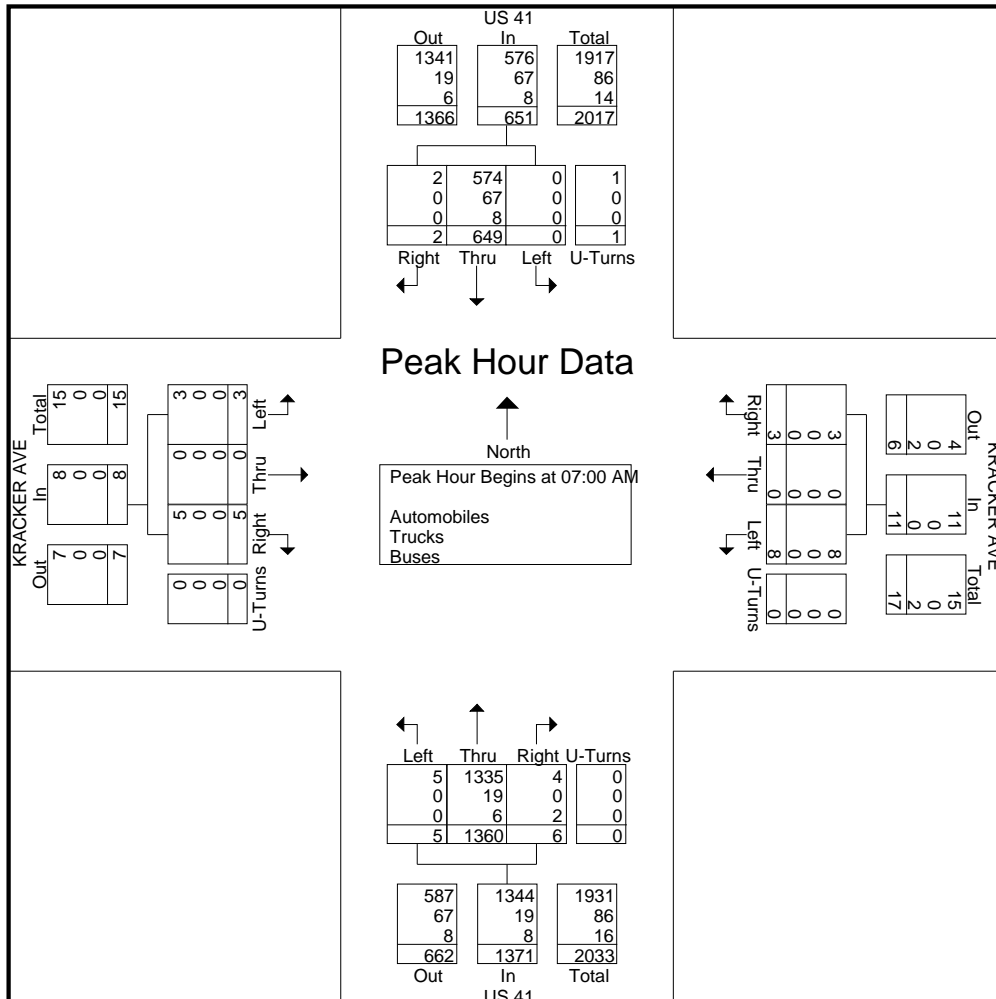





# Southern Traffic Services, Inc.

2911 Westfield Rd  
Gulf Breeze, FL 32563  
1-800-786-3374

*Traffic is our only business!*

US 41 @ Kracker Ave  
Tampa, FL

File Name : 13015-1 US 41 @ Kracker Ave  
Site Code : 13015-1  
Start Date : 1/10/2013  
Page No : 4

Start Time	US 41 Southbound					KRACKER AVE Westbound					US 41 Northbound					KRACKER AVE Eastbound					Int. Total
	Left	Thru	Right	U-Turns	App. Total	Left	Thru	Right	U-Turns	App. Total	Left	Thru	Right	U-Turns	App. Total	Left	Thru	Right	U-Turns	App. Total	

Peak Hour Analysis From 12:00 PM to 05:45 PM - Peak 1 of 1

Peak Hour for Entire Intersection Begins at 04:45 PM

04:45 PM	0	310	0	0	310	0	0	1	0	1	0	156	1	0	157	0	0	0	0	0	468
05:00 PM	0	332	1	1	334	3	1	2	0	6	0	177	1	3	181	2	0	1	0	3	524
05:15 PM	1	361	1	0	363	3	0	2	0	5	1	170	1	1	173	0	0	1	0	1	542
05:30 PM	2	384	1	0	387	0	0	1	0	1	0	171	4	0	175	0	0	0	0	0	563
Total Volume	3	1387	3	1	1394	6	1	6	0	13	1	674	7	4	686	2	0	2	0	4	2097
% App. Total	0.2	99.5	0.2	0.1		46.2	7.7	46.2	0		0.1	98.3	1	0.6		50	0	50	0		
PHF	.375	.903	.750	.250	.901	.500	.250	.750	.000	.542	.250	.952	.438	.333	.948	.250	.000	.500	.000	.333	.931
Automobiles	3	1365	3	1	1372	5	1	5	0	11	1	641	7	4	653	2	0	2	0	4	2040
% Automobiles	100	98.4	100	100	98.4	83.3	100	83.3	0	84.6	100	95.1	100	100	95.2	100	0	100	0	100	97.3
Trucks	0	18	0	0	18	1	0	1	0	2	0	31	0	0	31	0	0	0	0	0	51
% Trucks	0	1.3	0	0	1.3	16.7	0	16.7	0	15.4	0	4.6	0	0	4.5	0	0	0	0	0	2.4
Buses	0	4	0	0	4	0	0	0	0	0	0	2	0	0	2	0	0	0	0	0	6
% Buses	0	0.3	0	0	0.3	0	0	0	0	0	0	0.3	0	0	0.3	0	0	0	0	0	0.3

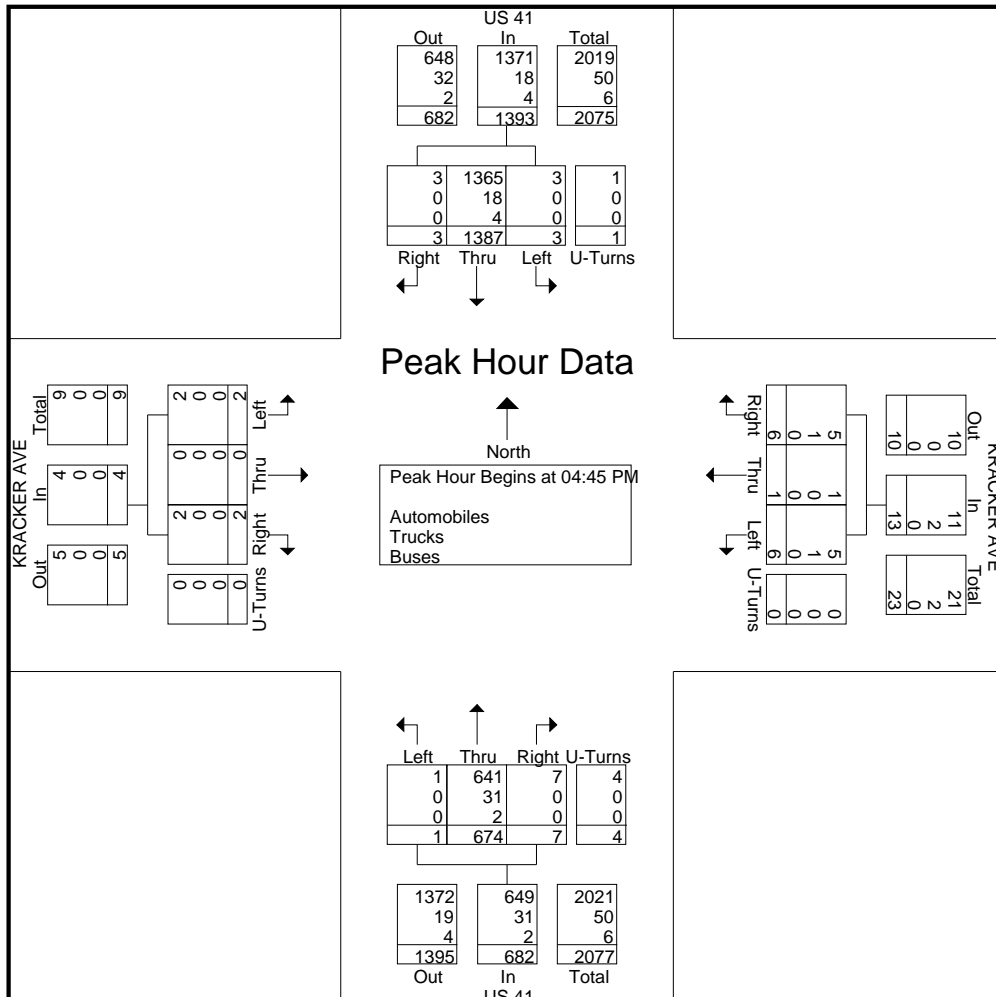



# Southern Traffic Services, Inc.

2911 Westfield Rd  
 Gulf Breeze, FL 32563  
 1-800-786-3374

*Traffic is our only business!*

US 41 @ Kracker Ave  
 Tampa, FL

File Name : 13015-1 US 41 @ Kracker Ave  
 Site Code : 13015-1  
 Start Date : 1/10/2013  
 Page No : 1

Groups Printed- Automobiles

Start Time	US 41 Southbound				KRACKER AVE Westbound				US 41 Northbound				KRACKER AVE Eastbound				Int. Total
	Left	Thru	Right	U-Turns	Left	Thru	Right	U-Turns	Left	Thru	Right	U-Turns	Left	Thru	Right	U-Turns	
07:00 AM	0	130	0	0	4	0	0	0	1	309	1	0	0	0	2	0	447
07:15 AM	0	129	0	0	2	0	3	0	1	353	0	0	2	0	2	0	492
07:30 AM	0	161	1	1	1	0	0	0	2	364	1	0	1	0	1	0	533
07:45 AM	0	154	1	0	1	0	0	0	1	309	2	0	0	0	0	0	468
Total	0	574	2	1	8	0	3	0	5	1335	4	0	3	0	5	0	1940
08:00 AM	0	87	0	0	2	0	0	0	0	278	1	0	1	0	0	0	369
08:15 AM	1	104	1	0	2	0	0	0	1	205	2	0	2	0	0	0	318
08:30 AM	0	99	0	0	0	0	0	0	1	183	0	0	0	0	1	0	284
08:45 AM	2	62	0	0	2	0	0	0	0	161	1	0	0	0	0	0	228
Total	3	352	1	0	6	0	0	0	2	827	4	0	3	0	1	0	1199
<b>**BREAK**</b>																	
04:00 PM	2	283	0	0	0	0	0	0	2	168	3	1	0	0	1	0	460
04:15 PM	1	276	1	1	0	0	0	0	1	143	0	1	2	0	2	0	428
04:30 PM	2	300	1	0	2	0	0	0	0	167	0	0	0	0	0	0	472
04:45 PM	0	301	0	0	0	0	1	0	0	144	1	0	0	0	0	0	447
Total	5	1160	2	1	2	0	1	0	3	622	4	2	2	0	3	0	1807
05:00 PM	0	324	1	1	2	1	1	0	0	171	1	3	2	0	1	0	508
05:15 PM	1	359	1	0	3	0	2	0	1	165	1	1	0	0	1	0	535
05:30 PM	2	381	1	0	0	0	1	0	0	161	4	0	0	0	0	0	550
05:45 PM	0	293	1	0	2	0	1	0	0	131	3	2	0	0	0	0	433
Total	3	1357	4	1	7	1	5	0	1	628	9	6	2	0	2	0	2026
Grand Total	11	3443	9	3	23	1	9	0	11	3412	21	8	10	0	11	0	6972
Apprch %	0.3	99.3	0.3	0.1	69.7	3	27.3	0	0.3	98.8	0.6	0.2	47.6	0	52.4	0	
Total %	0.2	49.4	0.1	0	0.3	0	0.1	0	0.2	48.9	0.3	0.1	0.1	0	0.2	0	



# Southern Traffic Services, Inc.

2911 Westfield Rd  
Gulf Breeze, FL 32563  
1-800-786-3374

*Traffic is our only business!*

US 41 @ Kracker Ave  
Tampa, FL

File Name : 13015-1 US 41 @ Kracker Ave  
Site Code : 13015-1  
Start Date : 1/10/2013  
Page No : 2

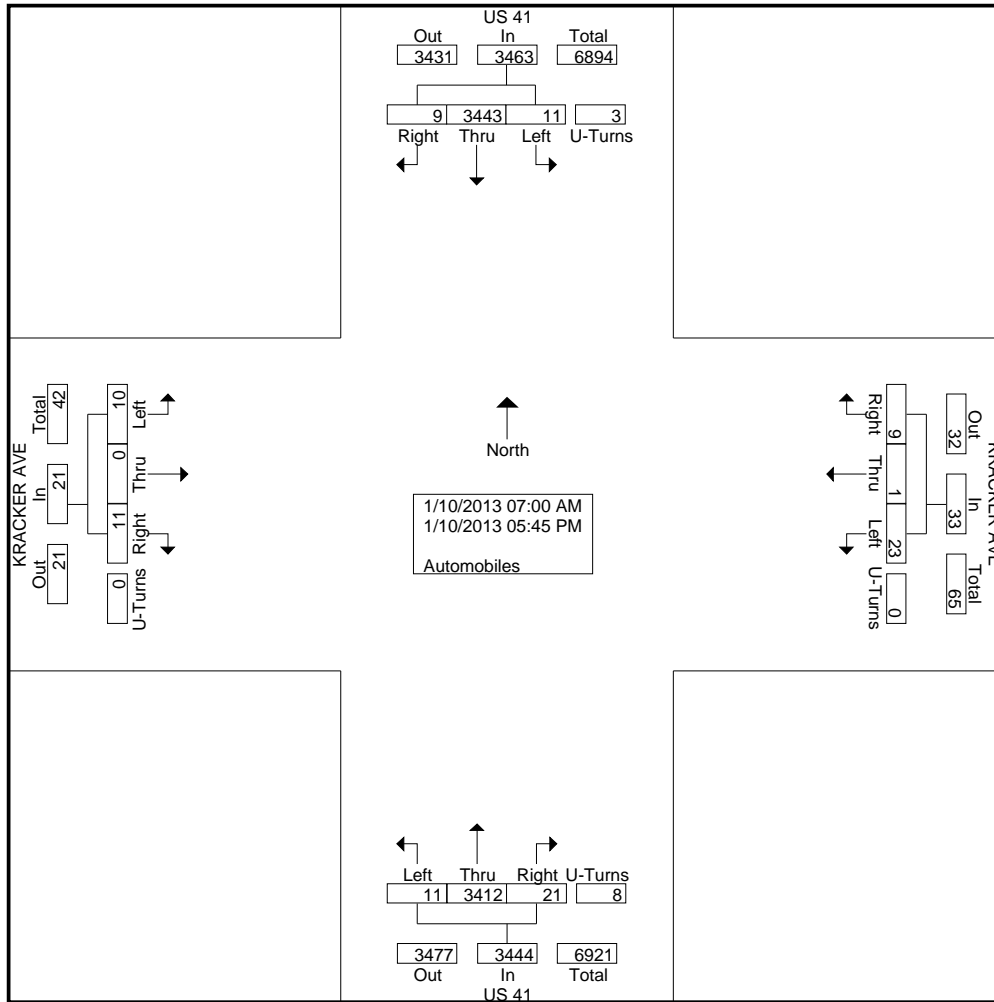



# Southern Traffic Services, Inc.

2911 Westfield Rd  
 Gulf Breeze, FL 32563  
 1-800-786-3374

*Traffic is our only business!*

US 41 @ Kracker Ave  
 Tampa, FL

File Name : 13015-1 US 41 @ Kracker Ave  
 Site Code : 13015-1  
 Start Date : 1/10/2013  
 Page No : 3

Start Time	US 41 Southbound				KRACKER AVE Westbound				US 41 Northbound				KRACKER AVE Eastbound				Int. Total				
	Thru	Right	U-Turns	App. Total	Left	Thru	Right	U-Turns	App. Total	Left	Thru	Right	U-Turns	App. Total	Left	Thru		Right	U-Turns	App. Total	
Peak Hour Analysis From 07:00 AM to 11:45 AM - Peak 1 of 1																					
Peak Hour for Entire Intersection Begins at 07:00 AM																					
07:00 AM	0	130	0	0	130	4	0	0	0	4	1	309	1	0	311	0	0	2	0	2	447
07:15 AM	0	129	0	0	129	2	0	3	0	5	1	353	0	0	354	2	0	2	0	4	492
07:30 AM	0	161	1	1	163	1	0	0	0	1	2	364	1	0	367	1	0	1	0	2	533
07:45 AM	0	154	1	0	155	1	0	0	0	1	1	309	2	0	312	0	0	0	0	0	468
Total Volume	0	574	2	1	577	8	0	3	0	11	5	1335	4	0	1344	3	0	5	0	8	1940
% App. Total	0	99.5	0.3	0.2		72.7	0	27.3	0		0.4	99.3	0.3	0		37.5	0	62.5	0		
PHF	.000	.891	.500	.250	.885	.500	.000	.250	.000	.550	.625	.917	.500	.000	.916	.375	.000	.625	.000	.500	.910

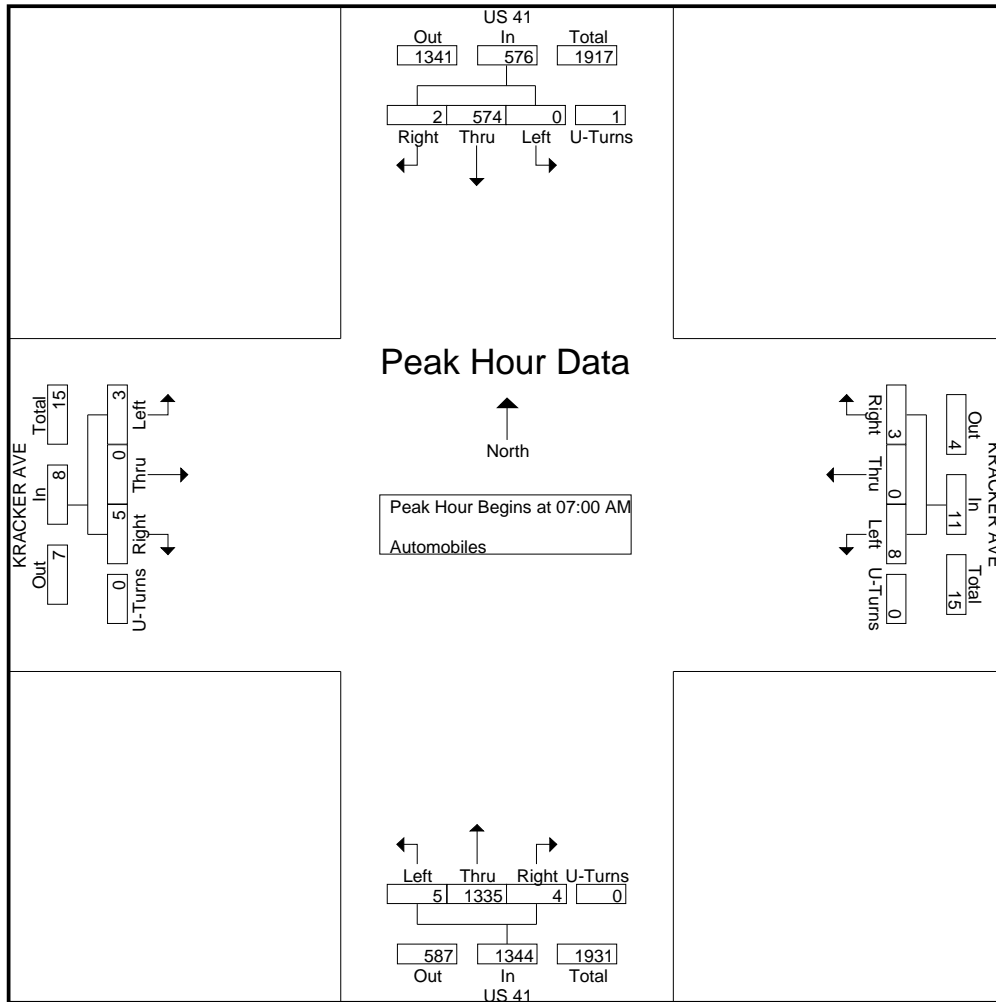



# Southern Traffic Services, Inc.

2911 Westfield Rd  
Gulf Breeze, FL 32563  
1-800-786-3374

*Traffic is our only business!*

US 41 @ Kracker Ave  
Tampa, FL

File Name : 13015-1 US 41 @ Kracker Ave  
Site Code : 13015-1  
Start Date : 1/10/2013  
Page No : 4

Start Time	US 41 Southbound					KRACKER AVE Westbound					US 41 Northbound					KRACKER AVE Eastbound					Int. Total
	Left	Thru	Right	U-Turns	App. Total	Left	Thru	Right	U-Turns	App. Total	Left	Thru	Right	U-Turns	App. Total	Left	Thru	Right	U-Turns	App. Total	
Peak Hour Analysis From 12:00 PM to 05:45 PM - Peak 1 of 1																					
Peak Hour for Entire Intersection Begins at 04:45 PM																					
04:45 PM	0	301	0	0	301	0	0	1	0	1	0	144	1	0	145	0	0	0	0	0	447
05:00 PM	0	324	1	1	326	2	1	1	0	4	0	171	1	3	175	2	0	1	0	3	508
05:15 PM	1	359	1	0	361	3	0	2	0	5	1	165	1	1	168	0	0	1	0	1	535
05:30 PM	2	381	1	0	384	0	0	1	0	1	0	161	4	0	165	0	0	0	0	0	550
Total Volume	3	1365	3	1	1372	5	1	5	0	11	1	641	7	4	653	2	0	2	0	4	2040
% App. Total	0.2	99.5	0.2	0.1		45.5	9.1	45.5	0		0.2	98.2	1.1	0.6		50	0	50	0		
PHF	.375	.896	.750	.250	.893	.417	.250	.625	.000	.550	.250	.937	.438	.333	.933	.250	.000	.500	.000	.333	.927

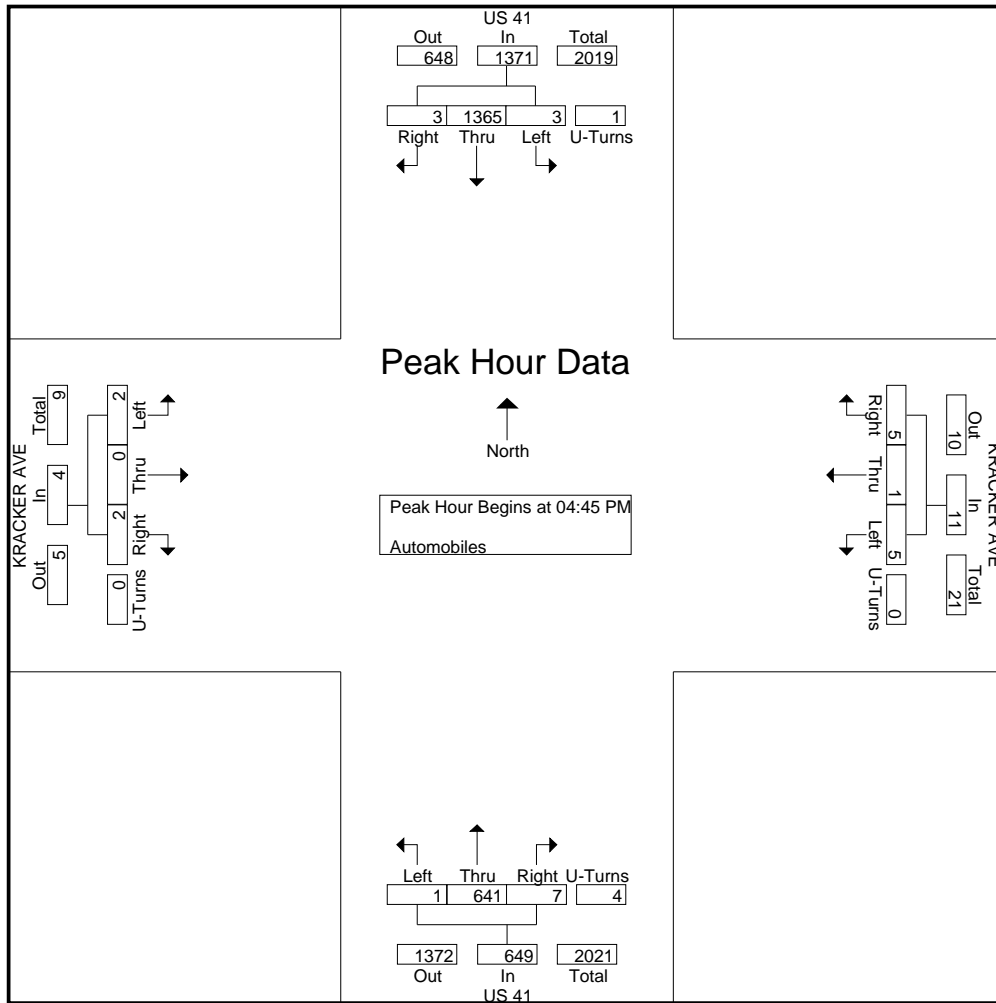





# Southern Traffic Services, Inc.

2911 Westfield Rd  
 Gulf Breeze, FL 32563  
 1-800-786-3374

*Traffic is our only business!*

US 41 @ Kracker Ave  
 Tampa, FL

File Name : 13015-1 US 41 @ Kracker Ave  
 Site Code : 13015-1  
 Start Date : 1/10/2013  
 Page No : 2

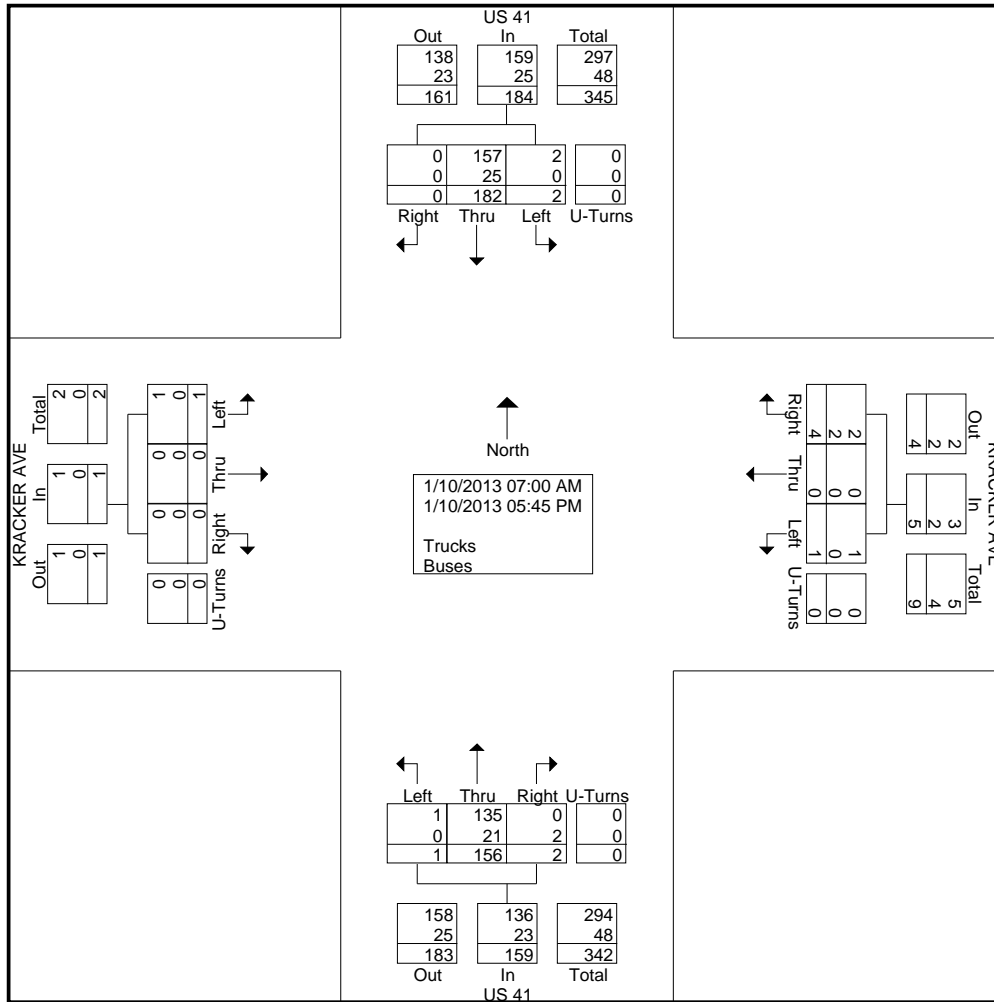



# Southern Traffic Services, Inc.

2911 Westfield Rd  
Gulf Breeze, FL 32563  
1-800-786-3374

*Traffic is our only business!*

US 41 @ Kracker Ave  
Tampa, FL

File Name : 13015-1 US 41 @ Kracker Ave  
Site Code : 13015-1  
Start Date : 1/10/2013  
Page No : 3

Start Time	US 41 Southbound				KRACKER AVE Westbound				US 41 Northbound				KRACKER AVE Eastbound				Int. Total				
	Thru	Right	U-Turns	App. Total	Left	Thru	Right	U-Turns	App. Total	Left	Thru	Right	U-Turns	App. Total	Left	Thru		Right	U-Turns	App. Total	
Peak Hour Analysis From 07:00 AM to 11:45 AM - Peak 1 of 1																					
Peak Hour for Entire Intersection Begins at 07:00 AM																					
07:00 AM	0	20	0	0	20	0	0	0	0	0	0	6	1	0	7	0	0	0	0	0	0
07:15 AM	0	19	0	0	19	0	0	0	0	0	0	8	1	0	9	0	0	0	0	0	0
07:30 AM	0	20	0	0	20	0	0	0	0	0	0	6	0	0	6	0	0	0	0	0	0
07:45 AM	0	16	0	0	16	0	0	0	0	0	0	5	0	0	5	0	0	0	0	0	0
Total Volume	0	75	0	0	75	0	0	0	0	0	0	25	2	0	27	0	0	0	0	0	0
% App. Total	0	100	0	0	0	0	0	0	0	0	0	92.6	7.4	0	0	0	0	0	0	0	0
PHF	.000	.938	.000	.000	.938	.000	.000	.000	.000	.000	.000	.781	.500	.000	.750	.000	.000	.000	.000	.000	.911

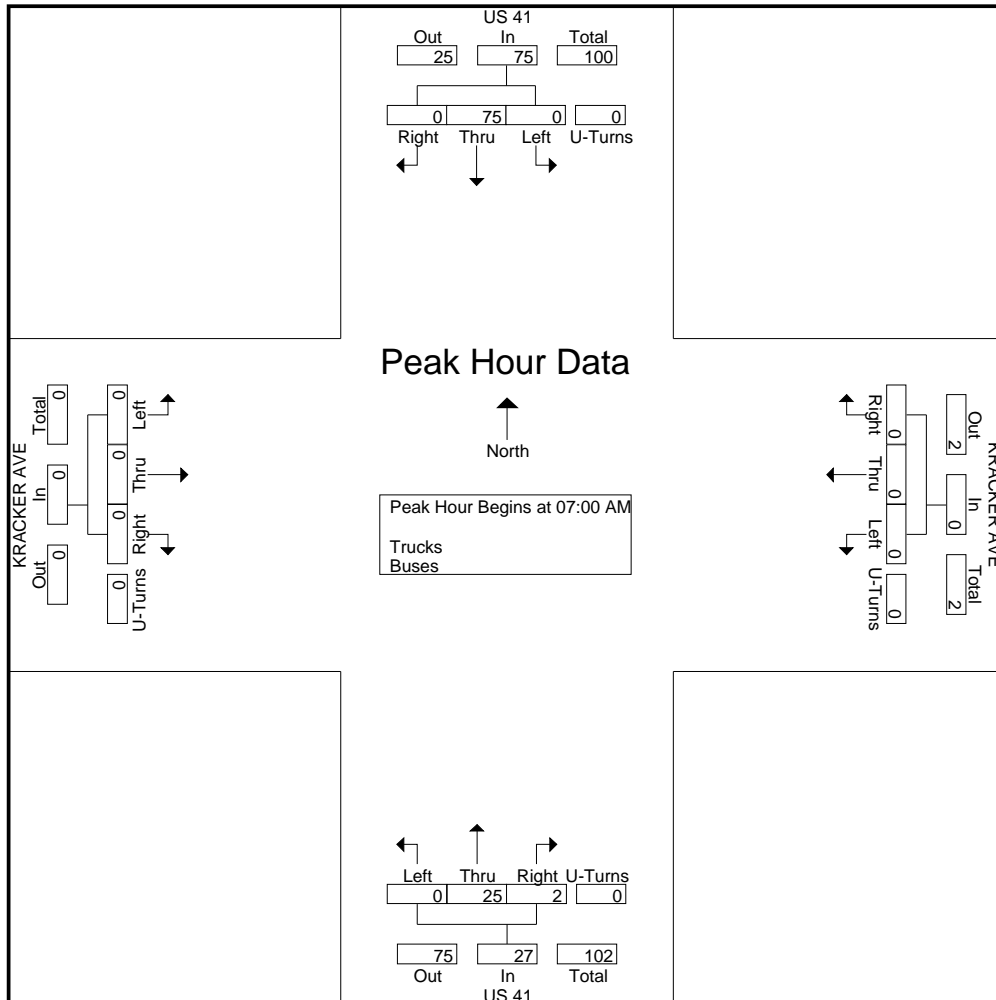





# Southern Traffic Services, Inc.

2911 Westfield Rd  
Gulf Breeze, FL 32563  
1-800-786-3374

*Traffic is our only business!*

US 41 @ Kracker Ave  
Tampa, FL

File Name : 13015-1 US 41 @ Kracker Ave  
Site Code : 13015-1  
Start Date : 1/10/2013  
Page No : 4

Start Time	US 41 Southbound					KRACKER AVE Westbound					US 41 Northbound					KRACKER AVE Eastbound					Int. Total
	Left	Thru	Right	U-Turns	App. Total	Left	Thru	Right	U-Turns	App. Total	Left	Thru	Right	U-Turns	App. Total	Left	Thru	Right	U-Turns	App. Total	
Peak Hour Analysis From 12:00 PM to 05:45 PM - Peak 1 of 1																					
Peak Hour for Entire Intersection Begins at 04:00 PM																					
04:00 PM	1	6	0	0	7	0	0	0	0	0	0	20	0	0	20	0	0	0	0	0	27
04:15 PM	0	17	0	0	17	0	0	1	0	1	1	15	0	0	16	0	0	0	0	0	34
04:30 PM	0	4	0	0	4	0	0	0	0	0	0	14	0	0	14	1	0	0	0	1	19
04:45 PM	0	9	0	0	9	0	0	0	0	0	0	12	0	0	12	0	0	0	0	0	21
Total Volume	1	36	0	0	37	0	0	1	0	1	1	61	0	0	62	1	0	0	0	1	101
% App. Total	2.7	97.3	0	0		0	0	100	0		1.6	98.4	0	0		100	0	0	0		
PHF	.250	.529	.000	.000	.544	.000	.000	.250	.000	.250	.250	.763	.000	.000	.775	.250	.000	.000	.000	.250	.743

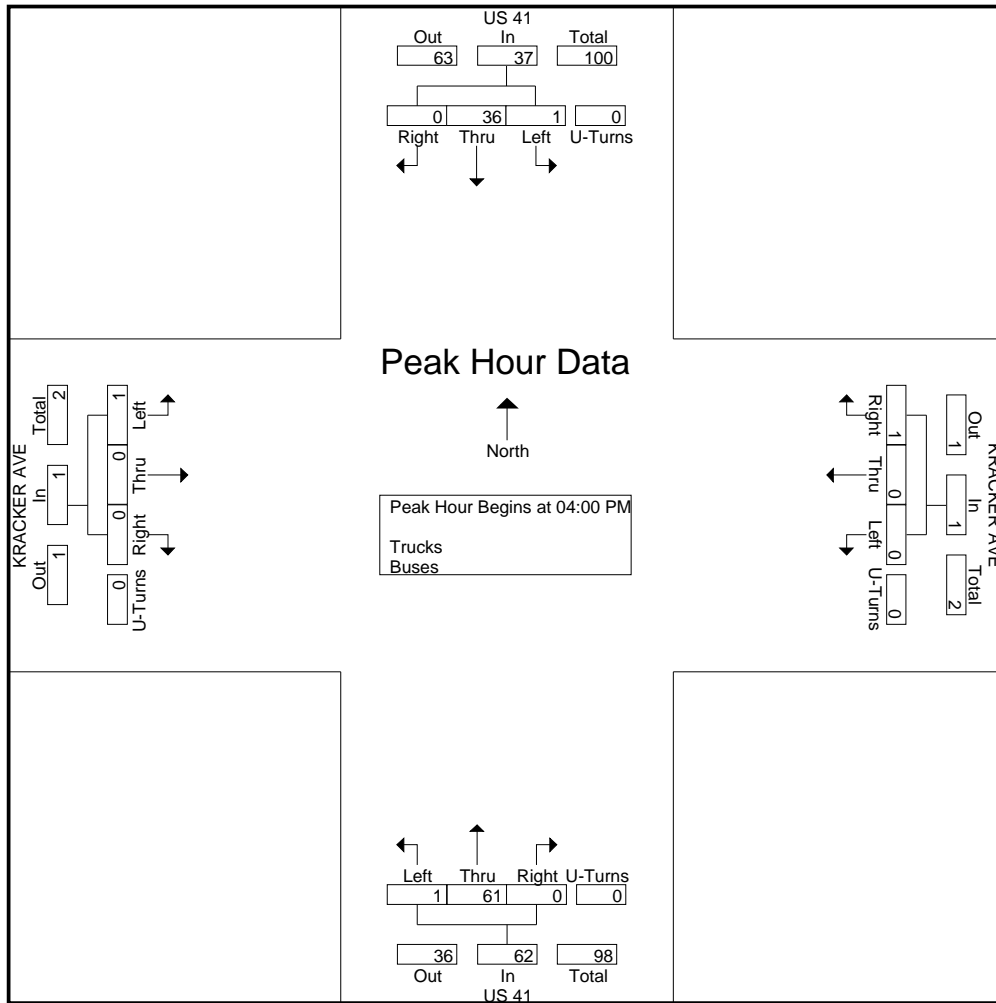



# Southern Traffic Services, Inc.

2911 Westfield Rd  
Gulf Breeze, FL 32563  
1-800-786-3374

*Traffic is our only business!*

US 41 @ Kracker Ave  
Tampa, FL

File Name : 13015-1 US 41 @ Kracker Ave Peds  
Site Code : 13015-1  
Start Date : 1/10/2013  
Page No : 1

### Groups Printed- Peds

Start Time	US 41	KRACKER AVE	US 41	KRACKER AVE	Int. Total
	Southbound	Westbound	Northbound	Eastbound	
	Peds	Peds	Peds	Peds	
07:00 AM	0	0	0	0	0
07:15 AM	0	0	0	0	0
07:30 AM	0	0	0	0	0
07:45 AM	0	0	0	0	0
Total	0	0	0	0	0
08:00 AM	0	0	0	0	0
08:15 AM	1	0	0	0	1
08:30 AM	0	0	0	0	0
08:45 AM	0	0	0	0	0
Total	1	0	0	0	1
09:00 AM	0	0	0	0	0
09:15 AM	0	0	0	0	0
09:30 AM	0	0	0	0	0
09:45 AM	0	0	0	0	0
Total	0	0	0	0	0
10:00 AM	0	0	0	0	0
10:15 AM	0	0	0	0	0
10:30 AM	0	0	0	0	0
10:45 AM	0	0	0	0	0
Total	0	0	0	0	0
11:00 AM	0	0	0	0	0
11:15 AM	0	0	0	0	0
11:30 AM	0	0	0	0	0
11:45 AM	0	0	0	0	0
Total	0	0	0	0	0
12:00 PM	0	0	0	0	0
12:15 PM	0	0	0	0	0
12:30 PM	0	0	0	0	0
12:45 PM	0	0	0	0	0
Total	0	0	0	0	0
01:00 PM	0	0	0	0	0
01:15 PM	0	0	0	0	0
01:30 PM	0	0	0	0	0
01:45 PM	0	0	0	0	0
Total	0	0	0	0	0
02:00 PM	0	0	0	0	0
02:15 PM	0	0	0	0	0
02:30 PM	0	0	0	0	0
02:45 PM	0	0	0	0	0
Total	0	0	0	0	0
03:00 PM	0	0	0	0	0
03:15 PM	0	0	0	0	0
03:30 PM	0	0	0	0	0
03:45 PM	0	0	0	0	0
Total	0	0	0	0	0



# Southern Traffic Services, Inc.

2911 Westfield Rd  
 Gulf Breeze, FL 32563  
 1-800-786-3374

*Traffic is our only business!*

US 41 @ Kracker Ave  
 Tampa, FL

File Name : 13015-1 US 41 @ Kracker Ave Peds  
 Site Code : 13015-1  
 Start Date : 1/10/2013  
 Page No : 2

Groups Printed- Peds

Start Time	US 41 Southbound	KRACKER AVE Westbound	US 41 Northbound	KRACKER AVE Eastbound	Int. Total
	Peds	Peds	Peds	Peds	
04:00 PM	0	0	0	0	0
04:15 PM	0	0	2	0	2
04:30 PM	0	0	1	0	1
04:45 PM	0	0	0	0	0
Total	0	0	3	0	3
05:00 PM	0	0	0	0	0
05:15 PM	0	0	0	0	0
05:30 PM	0	0	0	0	0
05:45 PM	1	0	0	0	1
Total	1	0	0	0	1
Grand Total	2	0	3	0	5
Apprch %	100	0	100	0	
Total %	40	0	60	0	

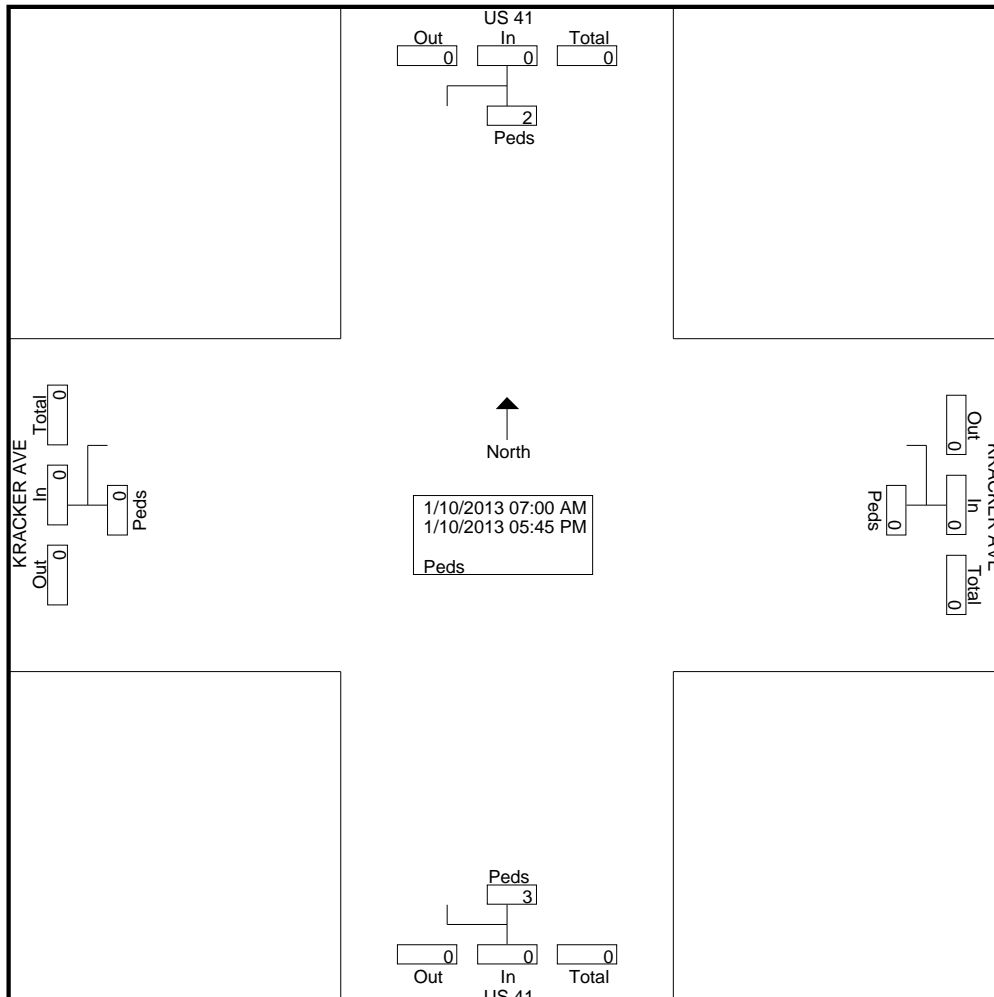

# Southern Traffic Services, Inc.

## Event Counts

US 41 north of Kracker Avenue

Northbound

**Datasets:**

**Site:** [011] I5156  
**Input A:** 5 - South bound A>B, North bound B>A. - Excluded from totals. (0)  
**Input B:** 0 - Unused or unknown. - Added to totals. (1)  
**Survey Duration:** 14:25 Monday, January 07, 2013 => 12:07 Friday, January 11, 2013  
**File:** G:\DATA\2013\Private\13015\brandon\machine data 1-7-13\UM011.eco (Plus)  
**Identifier:** Q889XNMT MC56-L5 [MC55] (c)Microcom 19Oct04  
**Algorithm:** Event Count  
**Data type:** Axle sensors - Paired (Class, Speed, Count)

**Profile:**

**Filter time:** 0:00 Tuesday, January 08, 2013 => 0:00 Friday, January 11, 2013  
**Name:** Factory default profile  
**Scheme:** Count events divided by two.  
**Units:** Non metric (ft, mi, ft/s, mph, lb, ton)  
**In profile:** Events = 34382

**Tuesday, January 08, 2013=11514, 15 minute drops**

0000	0100	0200	0300	0400	0500	0600	0700	0800	0900	1000	1100	1200	1300	1400	1500	1600	1700	1800	1900	2000	2100	2200	2300	
39	31	21	53	126	458	1118	1495	951	653	567	590	608	631	722	799	692	711	450	251	192	169	107	80	
8	9	7	15	16	79	204	368	290	151	142	167	130	150	160	188	165	173	127	79	32	48	28	23	15
11	9	4	14	20	99	268	377	269	173	142	152	161	181	197	202	151	211	151	83	49	47	28	26	19
13	8	5	14	40	118	315	379	201	162	144	139	153	150	199	228	186	169	100	55	57	40	24	22	16
7	5	5	10	50	162	331	371	191	167	139	132	164	150	166	181	190	158	72	34	54	34	27	9	10

AM Peak 0700 - 0800 (1495), AM PHF=0.99 PM Peak 1500 - 1600 (799), PM PHF=0.88

**Wednesday, January 09, 2013=11510, 15 minute drops**

0000	0100	0200	0300	0400	0500	0600	0700	0800	0900	1000	1100	1200	1300	1400	1500	1600	1700	1800	1900	2000	2100	2200	2300	
60	24	30	53	122	489	1014	1388	891	682	602	555	614	645	685	774	743	744	506	267	211	213	122	76	
15	7	11	15	16	81	187	314	277	189	148	130	138	200	176	187	191	200	149	94	51	77	38	28	10
19	4	6	16	30	93	269	355	242	154	158	141	157	147	179	155	186	205	128	68	68	50	28	10	14
16	8	6	10	34	135	272	360	204	165	152	135	159	149	166	238	193	184	112	52	48	41	29	18	4
10	5	7	12	42	180	286	359	168	174	144	149	160	149	164	194	173	155	117	53	44	45	27	20	9

AM Peak 0700 - 0800 (1388), AM PHF=0.96 PM Peak 1530 - 1630 (809), PM PHF=0.85

**Thursday, January 10, 2013=11358, 15 minute drops**

0000	0100	0200	0300	0400	0500	0600	0700	0800	0900	1000	1100	1200	1300	1400	1500	1600	1700	1800	1900	2000	2100	2200	2300	
37	34	26	43	121	452	1017	1399	905	620	574	617	579	616	703	806	709	661	525	284	261	180	118	71	
10	6	7	11	22	75	183	337	284	161	139	145	127	144	169	162	174	177	176	71	61	53	26	18	11
14	7	7	15	24	88	211	353	240	154	163	170	151	150	187	191	165	169	125	89	85	51	33	18	16
4	13	6	9	32	128	341	389	195	170	19	153	154	169	197	253	185	169	113	58	53	37	32	23	10
9	8	6	8	43	161	282	320	186	135	253	149	147	153	150	200	185	146	111	66	62	39	27	12	12

AM Peak 0700 - 0800 (1399), AM PHF=0.90 PM Peak 1515 - 1615 (818), PM PHF=0.81

# Southern Traffic Services, Inc.

## Event Counts

US 41 north of Kracker Avenue

Southbound

**Datasets:**

**Site:** [011] I5156  
**Input A:** 5 - South bound A>B, North bound B>A. - Added to totals. (1)  
**Input B:** 0 - Unused or unknown. - Excluded from totals. (0)  
**Survey Duration:** 14:25 Monday, January 07, 2013 => 12:07 Friday, January 11, 2013  
**File:** G:\DATA\2013\Private\13015\brandon\machine data 1-7-13\UM011.eco (Plus)  
**Identifier:** Q889XNMT MC56-L5 [MC55] (c)Microcom 19Oct04  
**Algorithm:** Event Count  
**Data type:** Axle sensors - Paired (Class, Speed, Count)

**Profile:**

**Filter time:** 0:00 Tuesday, January 08, 2013 => 0:00 Friday, January 11, 2013  
**Name:** Factory default profile  
**Scheme:** Count events divided by two.  
**Units:** Non metric (ft, mi, ft/s, mph, lb, ton)  
**In profile:** Events = 34435

**Tuesday, January 08, 2013=11434, 15 minute drops**

0000	0100	0200	0300	0400	0500	0600	0700	0800	0900	1000	1100	1200	1300	1400	1500	1600	1700	1800	1900	2000	2100	2200	2300	
119	47	36	54	94	199	553	684	554	488	479	558	574	596	588	868	1128	1313	1005	502	387	267	219	122	
34	13	6	12	14	26	97	159	132	106	108	122	161	132	142	96	261	298	288	153	118	63	69	30	25
60	11	7	13	19	34	152	164	139	140	124	144	150	120	159	250	271	355	304	130	100	67	71	34	21
18	10	13	13	25	67	124	189	154	115	117	153	114	186	150	247	291	353	233	96	81	64	48	34	9
7	13	10	16	36	72	180	172	129	127	130	139	149	158	137	275	305	307	180	123	88	73	31	24	9

AM Peak 0645 - 0745 (692), AM PHF=0.92 PM Peak 1700 - 1800 (1313), PM PHF=0.92

**Wednesday, January 09, 2013=11589, 15 minute drops**

0000	0100	0200	0300	0400	0500	0600	0700	0800	0900	1000	1100	1200	1300	1400	1500	1600	1700	1800	1900	2000	2100	2200	2300	
64	48	47	35	70	238	553	700	590	496	526	500	589	570	661	856	1179	1325	939	509	392	328	242	132	
25	12	13	4	13	15	112	171	147	124	139	119	114	145	155	163	300	293	302	140	100	78	72	38	30
21	10	14	16	18	36	123	152	129	132	134	132	168	132	149	174	270	366	253	105	103	91	56	31	14
9	14	13	8	9	80	169	205	163	111	120	136	144	137	156	263	301	332	218	165	102	85	63	38	28
9	12	7	7	30	107	149	172	151	129	133	113	163	156	201	256	308	334	166	99	87	74	51	25	19

AM Peak 0700 - 0800 (700), AM PHF=0.85 PM Peak 1715 - 1815 (1334), PM PHF=0.91

**Thursday, January 10, 2013=11412, 15 minute drops**

0000	0100	0200	0300	0400	0500	0600	0700	0800	0900	1000	1100	1200	1300	1400	1500	1600	1700	1800	1900	2000	2100	2200	2300	
91	57	46	32	75	216	542	729	476	511	454	527	544	579	672	885	1108	1341	930	559	391	264	226	157	
30	13	9	6	15	36	108	168	113	113	109	144	150	142	144	195	267	321	267	180	108	74	47	17	28
14	10	12	7	16	30	153	176	132	132	96	127	136	142	186	210	260	327	233	154	101	75	52	66	33
28	19	16	12	19	51	156	189	136	142	116	113	137	96	152	214	277	377	232	129	95	49	64	34	25
19	15	9	7	25	99	125	196	95	124	133	143	121	199	190	266	304	316	198	96	87	66	63	40	18

AM Peak 0700 - 0800 (729), AM PHF=0.93 PM Peak 1700 - 1800 (1341), PM PHF=0.89

# Southern Traffic Services, Inc.

## Event Counts

**US 41 south of Kracker Avenue**

**Northbound**

**Datasets:**

**Site:** [012] !C6501  
**Input A:** 5 - South bound A>B, North bound B>A. - Excluded from totals. (0)  
**Input B:** 0 - Unused or unknown. - Added to totals. (1)  
**Survey Duration:** 17:25 Monday, January 14, 2013 => 15:01 Friday, January 18, 2013  
**File:** G:\DATA\2013\Private\13015\resets\UM012.eco (Plus)  
**Identifier:** T525B6JS MC56-L5 [MC55] (c)Microcom 19Oct04  
**Algorithm:** Event Count  
**Data type:** Axle sensors - Paired (Class, Speed, Count)

**Profile:**

**Filter time:** 0:00 Tuesday, January 15, 2013 => 0:00 Friday, January 18, 2013  
**Name:** Factory default profile  
**Scheme:** Count events divided by two.  
**Units:** Non metric (ft, mi, ft/s, mph, lb, ton)  
**In profile:** Events = 33651

**Tuesday, January 15, 2013=10714, 15 minute drops**

0000	0100	0200	0300	0400	0500	0600	0700	0800	0900	1000	1100	1200	1300	1400	1500	1600	1700	1800	1900	2000	2100	2200	2300	
40	24	25	64	119	459	1087	1406	889	651	573	569	652	643	742	420	274	792	467	269	221	142	115	71	
15	5	8	15	21	76	207	334	289	183	37	132	170	167	182	192	73	269	134	77	59	42	34	19	10
6	8	4	18	26	100	280	350	240	166	249	154	130	137	208	74	69	197	132	74	56	29	34	17	9
10	6	6	14	26	136	320	371	191	155	146	140	174	199	195	61	65	178	105	77	59	33	19	19	10
9	5	7	17	46	147	280	351	169	147	141	143	178	140	157	93	67	148	96	41	47	38	28	16	12

AM Peak 0700 - 0800 (1406), AM PHF=0.95 PM Peak 1700 - 1800 (792), PM PHF=0.74

**Wednesday, January 16, 2013=11702, 15 minute drops**

0000	0100	0200	0300	0400	0500	0600	0700	0800	0900	1000	1100	1200	1300	1400	1500	1600	1700	1800	1900	2000	2100	2200	2300	
41	36	35	48	126	455	1020	1413	934	689	637	618	660	603	743	841	712	727	532	279	198	160	130	65	
10	9	8	10	19	76	182	359	286	185	155	170	168	138	167	199	197	219	160	71	53	56	40	17	10
9	6	11	10	42	101	259	346	248	161	181	148	165	157	205	178	155	178	151	84	61	43	35	18	11
10	11	8	16	28	136	275	379	211	144	164	176	153	165	190	266	179	176	110	64	41	36	26	18	5
12	10	8	12	37	142	304	329	189	199	137	124	174	143	181	198	181	154	111	60	43	25	29	12	1

AM Peak 0700 - 0800 (1413), AM PHF=0.93 PM Peak 1500 - 1600 (841), PM PHF=0.79

**Thursday, January 17, 2013=11235, 15 minute drops**

0000	0100	0200	0300	0400	0500	0600	0700	0800	0900	1000	1100	1200	1300	1400	1500	1600	1700	1800	1900	2000	2100	2200	2300	
27	31	41	58	162	424	1029	1429	943	682	641	600	574	594	697	806	644	651	424	241	184	165	109	79	
10	6	8	10	26	69	186	323	298	188	149	151	147	121	155	213	149	195	147	76	51	51	30	23	12
11	7	9	23	32	94	243	390	261	146	170	133	144	178	132	194	200	169	124	66	61	47	27	17	5
5	11	6	10	42	128	297	377	204	166	159	161	145	150	235	258	132	153	82	48	40	37	24	20	8
1	7	18	15	62	133	303	339	180	182	163	155	138	145	175	141	163	134	71	51	32	30	28	19	18

AM Peak 0700 - 0800 (1429), AM PHF=0.92 PM Peak 1445 - 1545 (840), PM PHF=0.81

# Southern Traffic Services, Inc.

## Event Counts

**US 41 south of Kracker Avenue**

**Southbound**

**Datasets:**

**Site:** [012] !C6501  
**Input A:** 5 - South bound A>B, North bound B>A. - Added to totals. (1)  
**Input B:** 0 - Unused or unknown. - Excluded from totals. (0)  
**Survey Duration:** 17:25 Monday, January 14, 2013 => 15:01 Friday, January 18, 2013  
**File:** G:\DATA\2013\Private\13015\resets\UM012.eco (Plus)  
**Identifier:** T525B6JS MC56-L5 [MC55] (c)Microcom 19Oct04  
**Algorithm:** Event Count  
**Data type:** Axle sensors - Paired (Class, Speed, Count)

**Profile:**

**Filter time:** 0:00 Tuesday, January 15, 2013 => 0:00 Friday, January 18, 2013  
**Name:** Factory default profile  
**Scheme:** Count events divided by two.  
**Units:** Non metric (ft, mi, ft/s, mph, lb, ton)  
**In profile:** Events = 33593

**Tuesday, January 15, 2013=10426, 15 minute drops**

0000	0100	0200	0300	0400	0500	0600	0700	0800	0900	1000	1100	1200	1300	1400	1500	1600	1700	1800	1900	2000	2100	2200	2300	
64	48	33	43	60	194	602	689	518	502	510	536	574	596	646	559	426	1365	939	516	369	283	229	125	
19	14	10	5	14	23	110	149	125	136	122	116	133	103	165	175	150	404	254	153	89	76	58	41	32
7	10	4	14	7	38	139	172	117	146	143	127	147	197	175	213	87	370	258	125	113	74	59	32	16
22	6	11	12	21	31	182	192	140	112	121	166	136	153	137	74	91	306	255	65	86	87	56	24	11
16	18	8	12	18	102	171	176	136	108	124	127	158	143	169	97	98	285	172	173	81	46	56	28	13

AM Peak 0700 - 0800 (689), AM PHF=0.90 PM Peak 1700 - 1800 (1365), PM PHF=0.84

**Wednesday, January 16, 2013=11610, 15 minute drops**

0000	0100	0200	0300	0400	0500	0600	0700	0800	0900	1000	1100	1200	1300	1400	1500	1600	1700	1800	1900	2000	2100	2200	2300	
72	42	29	40	74	222	627	694	592	421	492	560	617	621	678	878	1043	1282	1003	585	423	230	281	104	
32	10	2	7	8	17	118	164	151	111	139	156	137	136	138	185	247	279	176	201	105	100	124	31	37
16	10	10	17	9	44	149	175	147	91	137	135	151	155	185	208	250	338	373	152	103	65	65	21	15
11	12	8	2	27	64	174	189	165	138	122	127	167	156	180	219	284	355	244	41	127	41	52	37	19
13	10	9	14	30	97	186	166	129	81	94	142	162	174	175	266	262	310	210	191	88	24	40	15	24

AM Peak 0645 - 0745 (714), AM PHF=0.94 PM Peak 1700 - 1800 (1282), PM PHF=0.90

**Thursday, January 17, 2013=11557, 15 minute drops**

0000	0100	0200	0300	0400	0500	0600	0700	0800	0900	1000	1100	1200	1300	1400	1500	1600	1700	1800	1900	2000	2100	2200	2300	
95	41	41	52	84	216	607	704	601	507	553	541	549	631	712	870	1124	1244	796	629	329	268	222	141	
37	10	4	10	12	36	131	163	132	118	130	148	133	153	138	200	262	305	285	241	88	77	55	47	34
15	8	5	14	19	34	97	165	161	112	136	137	137	159	227	214	289	336	270	150	57	71	61	31	16
19	16	22	11	24	59	195	193	168	146	98	124	152	173	167	250	263	324	145	126	91	65	67	38	23
24	7	10	17	29	87	184	183	140	131	189	132	127	146	180	206	310	279	96	112	93	55	39	25	17

AM Peak 0630 - 0730 (707), AM PHF=0.91 PM Peak 1645 - 1745 (1275), PM PHF=0.95

# Southern Traffic Services, Inc.

## Event Counts

**Kracker Avenue east of US 41**

**Eastbound**

**Datasets:**

**Site:** [013] !4458  
**Input A:** 2 - East bound, A hit first. - Added to totals. (1)  
**Input B:** 0 - Unused or unknown. - Excluded from totals. (0)  
**Survey Duration:** 10:20 Monday, January 07, 2013 => 20:29 Friday, January 11, 2013  
**File:** G:\DATA\2013\Private\13015\brandon\machine data 1-7-13\UM013 EB.eco (Plus)  
**Identifier:** P837ZN16 MC56-L4 [MC55] (c)Microcom 19Sep03  
**Algorithm:** Event Count  
**Data type:** Axle sensors - Paired (Class, Speed, Count)

**Profile:**

**Filter time:** 0:00 Tuesday, January 08, 2013 => 0:00 Friday, January 11, 2013  
**Name:** Factory default profile  
**Scheme:** Count events divided by two.  
**Units:** Non metric (ft, mi, ft/s, mph, lb, ton)  
**In profile:** Events = 495

**Tuesday, January 08, 2013=173, 15 minute drops**

0000	0100	0200	0300	0400	0500	0600	0700	0800	0900	1000	1100	1200	1300	1400	1500	1600	1700	1800	1900	2000	2100	2200	2300
2	0	0	0	1	3	5	13	8	10	10	10	15	11	15	15	12	17	9	3	6	4	2	2
1	0	0	0	0	1	2	4	2	0	1	2	5	3	3	5	1	2	3	1	3	1	2	0
0	0	0	0	1	0	0	3	2	2	6	5	3	1	4	3	5	7	3	0	0	2	0	1
0	0	0	0	0	1	3	3	1	2	1	2	5	4	6	2	4	4	0	0	0	0	0	0
1	0	0	0	1	0	3	3	6	2	1	2	3	2	5	2	4	3	2	3	1	0	1	0

AM Peak 0930 - 1030 (15), AM PHF=0.63 PM Peak 1715 - 1815 (18), PM PHF=0.64

**Wednesday, January 09, 2013=167, 15 minute drops**

0000	0100	0200	0300	0400	0500	0600	0700	0800	0900	1000	1100	1200	1300	1400	1500	1600	1700	1800	1900	2000	2100	2200	2300
0	1	0	0	1	2	5	7	12	9	13	7	6	9	13	13	14	16	17	5	7	4	5	1
0	0	0	0	1	2	1	1	3	3	3	1	1	2	1	3	3	5	9	1	2	1	0	0
0	0	0	0	0	0	0	4	4	2	3	1	0	3	3	3	4	3	3	2	1	2	2	0
0	1	0	0	0	0	3	0	3	3	6	2	2	1	5	5	4	3	4	1	1	0	3	0
0	0	0	0	0	0	1	2	2	1	1	3	3	3	4	2	3	5	1	1	3	1	0	1

AM Peak 0945 - 1045 (13), AM PHF=0.54 PM Peak 1745 - 1845 (21), PM PHF=0.58

**Thursday, January 10, 2013=155, 15 minute drops**

0000	0100	0200	0300	0400	0500	0600	0700	0800	0900	1000	1100	1200	1300	1400	1500	1600	1700	1800	1900	2000	2100	2200	2300
1	1	2	0	1	2	6	7	9	14	4	8	16	6	14	10	10	15	11	4	6	6	0	2
0	0	1	0	1	0	2	3	1	1	0	1	2	0	1	3	5	5	6	0	1	3	0	1
0	0	0	0	0	0	0	1	4	7	2	3	3	2	6	4	0	5	4	1	2	2	0	0
1	1	1	0	0	1	2	1	1	1	0	3	9	2	3	2	4	3	1	2	2	0	0	0
0	0	0	0	0	1	2	2	3	5	2	1	2	2	4	1	1	2	0	1	1	1	0	1

AM Peak 0915 - 1015 (13), AM PHF=0.46 PM Peak 1200 - 1300 (16), PM PHF=0.44



# Southern Traffic Services, Inc.

## Event Counts

**Kracker Avenue east of US 41**

**Westbound**

**Datasets:**

**Site:** [013] I7055  
**Input A:** 4 - West bound, A hit first. - Added to totals. (1)  
**Input B:** 0 - Unused or unknown. - Excluded from totals. (0)  
**Survey Duration:** 10:17 Monday, January 07, 2013 => 12:43 Monday, January 14, 2013  
**File:** G:\DATA\2013\Private\13015\brandon\machine data 1-7-13\UM013 WB.eco (Plus)  
**Identifier:** U9517JMC MC56-L5 [MC55] (c)Microcom 19Oct04  
**Algorithm:** Event Count  
**Data type:** Axle sensors - Paired (Class, Speed, Count)

**Profile:**

**Filter time:** 0:00 Tuesday, January 08, 2013 => 0:00 Friday, January 11, 2013  
**Name:** Factory default profile  
**Scheme:** Count events divided by two.  
**Units:** Non metric (ft, mi, ft/s, mph, lb, ton)  
**In profile:** Events = 530

**Tuesday, January 08, 2013=179, 15 minute drops**

0000	0100	0200	0300	0400	0500	0600	0700	0800	0900	1000	1100	1200	1300	1400	1500	1600	1700	1800	1900	2000	2100	2200	2300
2	0	0	0	2	3	5	12	7	12	12	11	16	12	14	14	12	19	8	5	5	5	1	2
1	0	0	0	0	0	2	4	2	1	1	2	4	3	2	4	2	4	2	2	2	1	1	0
0	0	0	0	2	0	0	3	2	2	7	4	5	1	4	4	4	6	5	0	1	3	0	2
0	0	0	0	0	1	3	2	1	3	1	3	6	4	6	2	5	6	0	1	0	0	0	0
1	0	0	0	0	2	0	3	2	6	3	2	1	4	2	4	1	3	1	2	2	1	0	0

AM Peak 0930 - 1030 (17), AM PHF=0.61 PM Peak 1700 - 1800 (19), PM PHF=0.79

**Wednesday, January 09, 2013=184, 15 minute drops**

0000	0100	0200	0300	0400	0500	0600	0700	0800	0900	1000	1100	1200	1300	1400	1500	1600	1700	1800	1900	2000	2100	2200	2300
0	1	0	1	2	2	6	8	13	8	14	9	6	9	12	14	16	19	16	6	6	8	6	2
0	0	0	0	0	1	1	1	4	2	4	0	0	2	1	3	3	7	9	1	2	2	0	0
0	0	0	0	0	0	0	5	4	2	3	3	1	3	3	5	4	4	1	2	1	3	3	0
0	1	0	0	0	0	3	0	2	3	6	2	3	1	5	4	4	3	4	2	2	1	2	1
0	0	0	1	2	1	2	2	3	1	1	4	2	3	3	2	5	5	2	1	1	2	1	1

AM Peak 0945 - 1045 (14), AM PHF=0.58 PM Peak 1715 - 1815 (21), PM PHF=0.58

**Thursday, January 10, 2013=167, 15 minute drops**

0000	0100	0200	0300	0400	0500	0600	0700	0800	0900	1000	1100	1200	1300	1400	1500	1600	1700	1800	1900	2000	2100	2200	2300
0	1	1	0	2	3	6	12	10	15	7	8	15	8	16	15	5	15	11	4	8	4	0	1
0	0	1	0	1	0	2	4	3	0	1	1	2	1	1	6	1	6	6	1	2	2	0	1
0	0	0	0	1	0	0	5	2	8	2	3	3	2	5	5	0	5	5	1	2	1	0	0
0	1	0	0	0	1	1	1	2	1	2	3	8	3	5	3	3	2	0	1	3	0	0	2
0	0	0	0	0	2	3	2	3	6	2	1	2	2	5	1	1	2	0	1	1	1	0	0

AM Peak 0915 - 1015 (16), AM PHF=0.50 PM Peak 1415 - 1515 (21), PM PHF=0.88

# Southern Traffic Services, Inc.

## Event Counts

**Kracker Avenue west of US 41**

**Eastbound**

**Datasets:**

**Site:** [014] !C7026  
**Input A:** 2 - East bound, A hit first. - Added to totals. (1)  
**Input B:** 0 - Unused or unknown. - Excluded from totals. (0)  
**Survey Duration:** 10:16 Monday, January 07, 2013 => 20:57 Friday, January 11, 2013  
**File:** G:\DATA\2013\Private\13015\brandon\machine data 1-7-13\UM014 EB.eco (Plus)  
**Identifier:** U826JG4K MC56-L5 [MC55] (c)Microcom 19Oct04  
**Algorithm:** Event Count  
**Data type:** Axle sensors - Paired (Class, Speed, Count)

**Profile:**

**Filter time:** 0:00 Tuesday, January 08, 2013 => 0:00 Friday, January 11, 2013  
**Name:** Factory default profile  
**Scheme:** Count events divided by two.  
**Units:** Non metric (ft, mi, ft/s, mph, lb, ton)  
**In profile:** Events = 330

**Tuesday, January 08, 2013=118, 15 minute drops**

0000	0100	0200	0300	0400	0500	0600	0700	0800	0900	1000	1100	1200	1300	1400	1500	1600	1700	1800	1900	2000	2100	2200	2300	
0	0	0	0	2	0	5	8	13	10	5	6	9	7	9	10	7	7	3	6	3	6	2	0	
0	0	0	0	0	0	0	1	7	2	2	2	1	2	1	3	2	3	1	1	0	0	0	0	0
0	0	0	0	2	0	1	2	1	0	2	1	2	2	3	2	0	2	1	1	0	2	1	0	0
0	0	0	0	0	0	2	3	3	3	0	1	4	1	1	3	2	1	0	3	1	3	1	0	0
0	0	0	0	0	0	2	2	2	5	1	2	2	2	4	2	3	1	1	1	2	1	0	0	0

AM Peak 0715 - 0815 (14), AM PHF=0.50 PM Peak 1445 - 1545 (12), PM PHF=0.75

**Wednesday, January 09, 2013=125, 15 minute drops**

0000	0100	0200	0300	0400	0500	0600	0700	0800	0900	1000	1100	1200	1300	1400	1500	1600	1700	1800	1900	2000	2100	2200	2300	
0	1	0	1	0	2	3	6	12	4	4	8	9	9	9	12	12	8	11	6	3	3	2	0	
0	0	0	0	0	1	0	1	3	1	0	1	2	1	3	3	3	3	6	2	1	0	1	0	0
0	1	0	0	0	0	1	3	4	1	0	3	1	1	2	5	4	1	3	1	0	2	1	0	0
0	0	0	0	0	1	0	1	3	1	1	1	3	5	2	3	4	3	0	2	1	1	0	0	1
0	0	0	1	0	0	2	1	2	1	3	3	3	2	2	1	1	1	2	1	1	0	0	0	0

AM Peak 0800 - 0900 (12), AM PHF=0.75 PM Peak 1445 - 1545 (13), PM PHF=0.65

**Thursday, January 10, 2013=87, 15 minute drops**

0000	0100	0200	0300	0400	0500	0600	0700	0800	0900	1000	1100	1200	1300	1400	1500	1600	1700	1800	1900	2000	2100	2200	2300	
1	1	0	0	2	1	2	8	5	5	5	4	5	9	6	4	6	5	4	3	6	3	1	1	
0	0	0	0	1	0	0	1	1	1	2	0	1	3	2	0	1	1	0	0	2	2	0	1	0
0	0	0	0	1	0	0	3	2	2	2	2	2	3	0	3	4	3	1	2	1	0	0	0	0
1	1	0	0	0	0	0	3	2	0	0	1	2	2	2	0	0	0	2	1	1	1	0	0	0
0	0	0	0	0	1	2	1	0	2	1	1	0	1	2	1	1	1	1	0	2	0	1	0	0

AM Peak 0645 - 0745 (9), AM PHF=0.75 PM Peak 1300 - 1400 (9), PM PHF=0.75

# Southern Traffic Services, Inc.

## Event Counts

**Kracker Avenue west of US 41**

**Westbound**

**Datasets:**

**Site:** [014] I9142  
**Input A:** 4 - West bound, A hit first. - Added to totals. (1)  
**Input B:** 0 - Unused or unknown. - Excluded from totals. (0)  
**Survey Duration:** 10:16 Monday, January 07, 2013 => 20:30 Friday, January 11, 2013  
**File:** G:\DATA\2013\Private\13015\brandon\machine data 1-7-13\UM014 WB.eco (Plus)  
**Identifier:** AP456S0X MC56-L5 [MC55] (c)Microcom 19Oct04  
**Algorithm:** Event Count  
**Data type:** Axle sensors - Paired (Class, Speed, Count)

**Profile:**

**Filter time:** 0:00 Tuesday, January 08, 2013 => 0:00 Friday, January 11, 2013  
**Name:** Factory default profile  
**Scheme:** Count events divided by two.  
**Units:** Non metric (ft, mi, ft/s, mph, lb, ton)  
**In profile:** Events = 334

**Tuesday, January 08, 2013=121, 15 minute drops**

0000	0100	0200	0300	0400	0500	0600	0700	0800	0900	1000	1100	1200	1300	1400	1500	1600	1700	1800	1900	2000	2100	2200	2300
0	0	0	0	2	0	7	7	9	12	5	7	10	8	13	11	5	6	2	5	4	6	2	0
0	0	0	0	0	0	1	1	3	1	1	3	1	2	3	1	0	1	1	0	0	0	1	0
0	0	0	0	2	0	1	3	2	1	3	1	3	2	1	2	0	3	1	1	0	2	0	0
0	0	0	0	0	0	2	2	2	2	0	2	4	2	5	5	2	1	0	2	1	3	1	0
0	0	0	0	0	0	3	1	2	8	1	1	2	2	4	3	3	1	0	2	3	1	0	0

AM Peak 0930 - 1030 (14), AM PHF=0.44 PM Peak 1400 - 1500 (13), PM PHF=0.65

**Wednesday, January 09, 2013=125, 15 minute drops**

0000	0100	0200	0300	0400	0500	0600	0700	0800	0900	1000	1100	1200	1300	1400	1500	1600	1700	1800	1900	2000	2100	2200	2300
1	1	0	1	0	3	2	6	7	4	3	11	10	8	11	10	14	10	9	7	2	2	1	2
0	0	0	0	0	1	0	1	2	1	0	2	2	1	4	3	3	2	5	2	0	0	1	0
1	1	0	0	0	0	0	3	2	1	0	4	1	1	2	5	5	3	3	1	0	1	0	1
0	0	0	0	0	1	1	1	2	1	0	2	4	4	4	2	4	4	1	3	1	1	0	1
0	0	0	1	0	1	1	1	1	1	3	3	3	2	1	0	2	1	0	1	1	0	0	0

AM Peak 1045 - 1145 (11), AM PHF=0.69 PM Peak 1600 - 1700 (14), PM PHF=0.70

**Thursday, January 10, 2013=88, 15 minute drops**

0000	0100	0200	0300	0400	0500	0600	0700	0800	0900	1000	1100	1200	1300	1400	1500	1600	1700	1800	1900	2000	2100	2200	2300
0	1	0	0	3	0	1	9	4	6	5	4	5	8	6	4	6	6	4	3	8	3	1	1
0	0	0	0	1	0	0	2	0	1	2	0	1	2	1	0	1	1	0	0	2	2	0	1
0	0	0	0	2	0	1	2	2	2	2	2	1	3	1	3	3	1	2	1	1	0	0	0
0	1	0	0	0	0	0	3	2	1	0	0	2	1	2	0	1	0	2	1	1	1	0	0
0	0	0	0	0	0	0	2	0	2	1	2	1	2	2	1	1	2	1	0	4	0	1	0

AM Peak 0700 - 0800 (9), AM PHF=0.75 PM Peak 1230 - 1330 (8), PM PHF=0.67



# Southern Traffic Services, Inc.

2911 Westfield Rd  
Gulf Breeze, FL 32563  
1-800-786-3374

*Traffic is our only business!*

US 41 @ Ohio St  
Tampa, FL

File Name : 13015-2 us 41 @ ohio st  
Site Code : 13015-2  
Start Date : 1/10/2013  
Page No : 1

Groups Printed- Automobiles - Trucks - Buses

Start Time	US 41 Southbound			OHIO ST Westbound			US 41 Northbound			Int. Total
	Left	Thru	U-Turns	Left	Right	U-Turns	Thru	Right	U-Turns	
07:00 AM	4	147	3	4	6	0	330	3	2	499
07:15 AM	12	139	3	2	7	0	352	4	0	519
07:30 AM	4	195	8	4	1	0	390	4	0	606
07:45 AM	5	156	4	6	2	0	295	2	0	470
Total	25	637	18	16	16	0	1367	13	2	2094
08:00 AM	4	88	0	0	2	0	292	2	0	388
08:15 AM	6	132	3	2	7	0	233	1	0	384
08:30 AM	6	119	2	1	3	0	183	2	1	317
08:45 AM	6	69	4	1	0	0	171	2	0	253
Total	22	408	9	4	12	0	879	7	1	1342
<b>**BREAK**</b>										
04:00 PM	10	262	6	5	4	0	167	1	0	455
04:15 PM	7	285	15	5	5	0	153	2	0	472
04:30 PM	4	259	6	3	2	0	170	4	0	448
04:45 PM	9	300	7	3	5	0	166	3	0	493
Total	30	1106	34	16	16	0	656	10	0	1868
05:00 PM	5	327	7	2	7	0	178	2	0	528
05:15 PM	7	344	16	3	5	0	159	2	0	536
05:30 PM	7	374	13	4	5	0	161	3	0	567
05:45 PM	7	295	7	2	3	0	136	2	0	452
Total	26	1340	43	11	20	0	634	9	0	2083
Grand Total	103	3491	104	47	64	0	3536	39	3	7387
Apprch %	2.8	94.4	2.8	42.3	57.7	0	98.8	1.1	0.1	
Total %	1.4	47.3	1.4	0.6	0.9	0	47.9	0.5	0	
Automobiles	97	3347	103	45	61	0	3404	33	3	7093
% Automobiles	94.2	95.9	99	95.7	95.3	0	96.3	84.6	100	96
Trucks	5	119	0	2	1	0	107	4	0	238
% Trucks	4.9	3.4	0	4.3	1.6	0	3	10.3	0	3.2
Buses	1	25	1	0	2	0	25	2	0	56
% Buses	1	0.7	1	0	3.1	0	0.7	5.1	0	0.8



# Southern Traffic Services, Inc.

2911 Westfield Rd  
 Gulf Breeze, FL 32563  
 1-800-786-3374

*Traffic is our only business!*

US 41 @ Ohio St  
 Tampa, FL

File Name : 13015-2 us 41 @ ohio st  
 Site Code : 13015-2  
 Start Date : 1/10/2013  
 Page No : 2

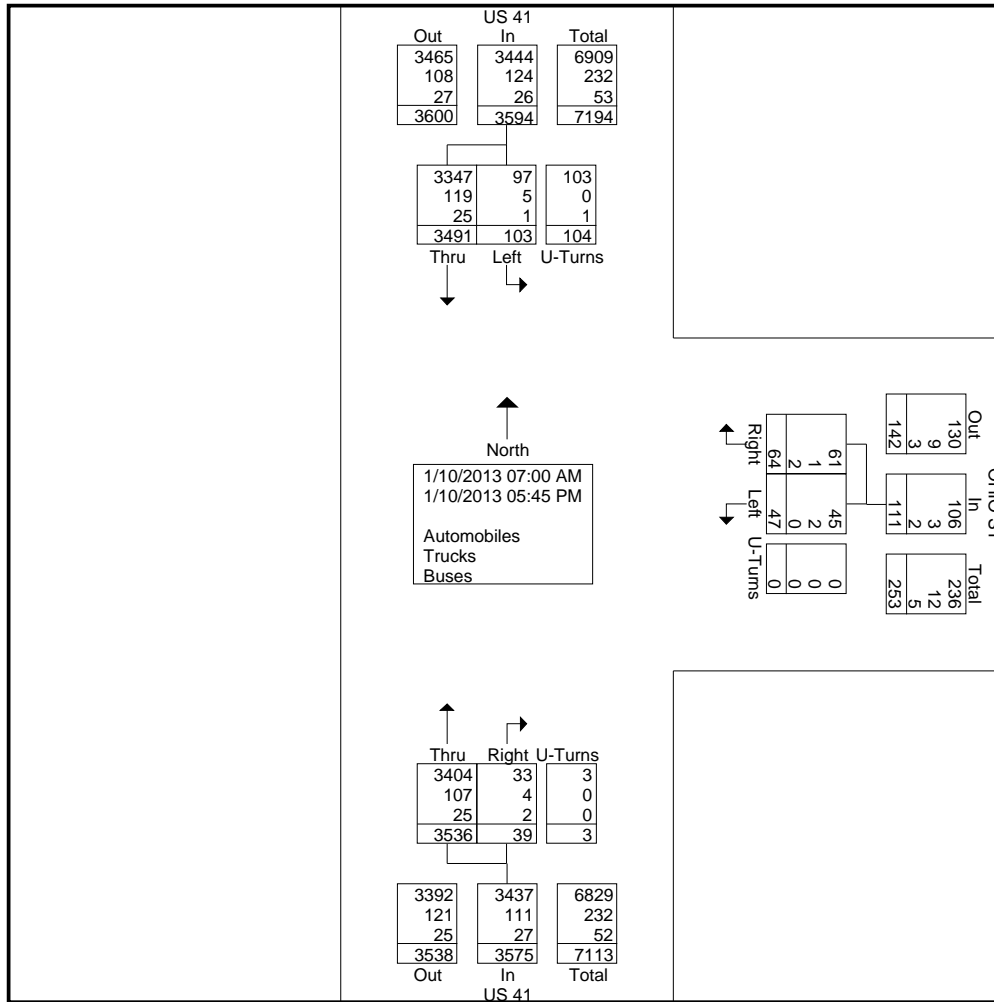



# Southern Traffic Services, Inc.

2911 Westfield Rd  
Gulf Breeze, FL 32563  
1-800-786-3374

*Traffic is our only business!*

US 41 @ Ohio St  
Tampa, FL

File Name : 13015-2 us 41 @ ohio st  
Site Code : 13015-2  
Start Date : 1/10/2013  
Page No : 3

Start Time	US 41 Southbound				OHIO ST Westbound				US 41 Northbound				Int. Total
	Left	Thru	U-Turns	App. Total	Left	Right	U-Turns	App. Total	Thru	Right	U-Turns	App. Total	
Peak Hour Analysis From 07:00 AM to 11:45 AM - Peak 1 of 1													
Peak Hour for Entire Intersection Begins at 07:00 AM													
07:00 AM	4	147	3	154	4	6	0	10	330	3	2	335	499
07:15 AM	12	139	3	154	2	7	0	9	352	4	0	356	519
07:30 AM	4	195	8	207	4	1	0	5	390	4	0	394	606
07:45 AM	5	156	4	165	6	2	0	8	295	2	0	297	470
<b>Total Volume</b>	<b>25</b>	<b>637</b>	<b>18</b>	<b>680</b>	<b>16</b>	<b>16</b>	<b>0</b>	<b>32</b>	<b>1367</b>	<b>13</b>	<b>2</b>	<b>1382</b>	<b>2094</b>
<b>% App. Total</b>	<b>3.7</b>	<b>93.7</b>	<b>2.6</b>	<b>90.9</b>	<b>87.5</b>	<b>81.3</b>	<b>0</b>	<b>84.4</b>	<b>98.9</b>	<b>0.9</b>	<b>0.1</b>	<b>98.3</b>	<b>95.7</b>
PHF	.521	.817	.563	.821	.667	.571	.000	.800	.876	.813	.250	.877	.864
Automobiles	20	580	18	618	14	13	0	27	1345	12	2	1359	2004
% Automobiles	80.0	91.1	100	90.9	87.5	81.3	0	84.4	98.4	92.3	100	98.3	95.7
Trucks	4	50	0	54	2	1	0	3	16	1	0	17	74
% Trucks	16.0	7.8	0	7.9	12.5	6.3	0	9.4	1.2	7.7	0	1.2	3.5
Buses	1	7	0	8	0	2	0	2	6	0	0	6	16
% Buses	4.0	1.1	0	1.2	0	12.5	0	6.3	0.4	0	0	0.4	0.8

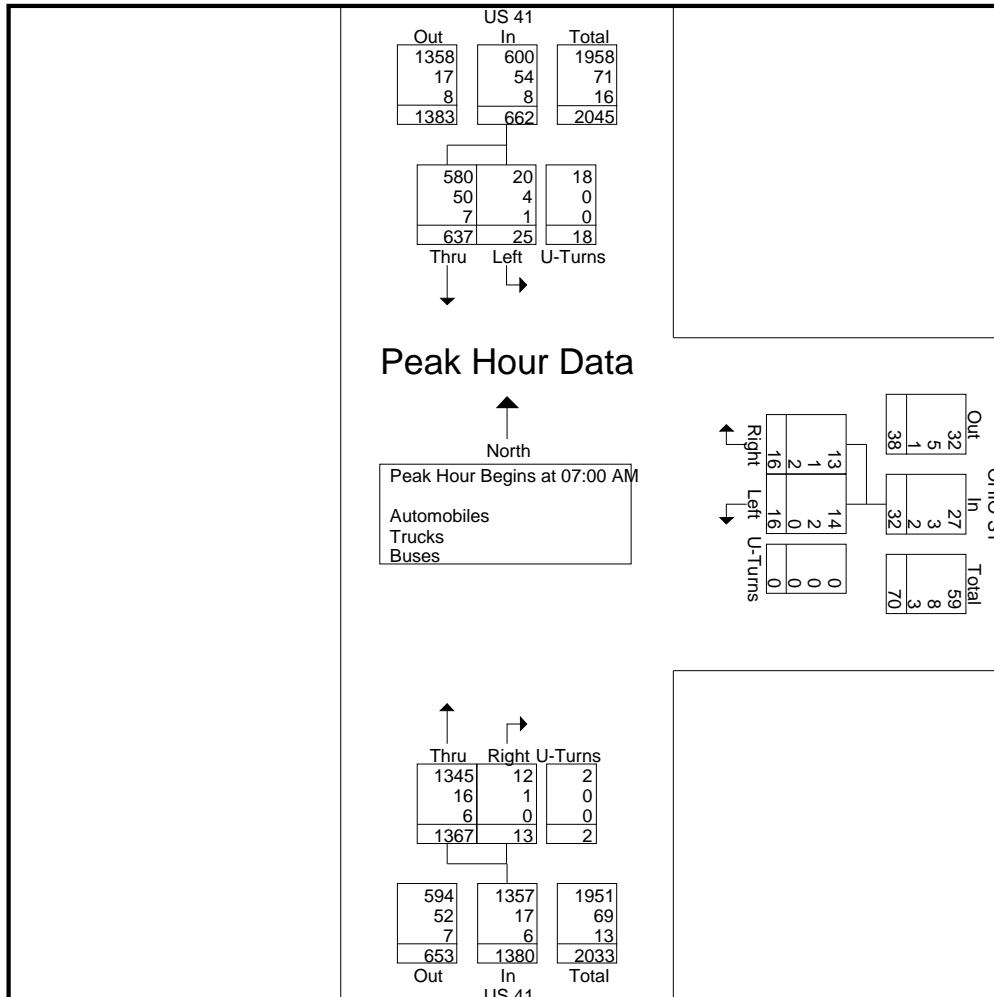



# Southern Traffic Services, Inc.

2911 Westfield Rd  
Gulf Breeze, FL 32563  
1-800-786-3374

*Traffic is our only business!*

US 41 @ Ohio St  
Tampa, FL

File Name : 13015-2 us 41 @ ohio st  
Site Code : 13015-2  
Start Date : 1/10/2013  
Page No : 4

Start Time	US 41 Southbound				OHIO ST Westbound				US 41 Northbound				Int. Total
	Left	Thru	U-Turns	App. Total	Left	Right	U-Turns	App. Total	Thru	Right	U-Turns	App. Total	
Peak Hour Analysis From 12:00 PM to 05:45 PM - Peak 1 of 1													
Peak Hour for Entire Intersection Begins at 04:45 PM													
04:45 PM	9	300	7	316	3	5	0	8	166	3	0	169	493
05:00 PM	5	327	7	339	2	7	0	9	178	2	0	180	528
05:15 PM	7	344	16	367	3	5	0	8	159	2	0	161	536
05:30 PM	7	374	13	394	4	5	0	9	161	3	0	164	567
<b>Total Volume</b>	<b>28</b>	<b>1345</b>	<b>43</b>	<b>1416</b>	<b>12</b>	<b>22</b>	<b>0</b>	<b>34</b>	<b>664</b>	<b>10</b>	<b>0</b>	<b>674</b>	<b>2124</b>
<b>% App. Total</b>	<b>2</b>	<b>95</b>	<b>3</b>		<b>35.3</b>	<b>64.7</b>	<b>0</b>		<b>98.5</b>	<b>1.5</b>	<b>0</b>		
<b>PHF</b>	<b>.778</b>	<b>.899</b>	<b>.672</b>	<b>.898</b>	<b>.750</b>	<b>.786</b>	<b>.000</b>	<b>.944</b>	<b>.933</b>	<b>.833</b>	<b>.000</b>	<b>.936</b>	<b>.937</b>
Automobiles	28	1327	43	1398	12	22	0	34	634	9	0	643	2075
% Automobiles	100	98.7	100	98.7	100	100	0	100	95.5	90.0	0	95.4	97.7
Trucks	0	14	0	14	0	0	0	0	28	1	0	29	43
% Trucks	0	1.0	0	1.0	0	0	0	0	4.2	10.0	0	4.3	2.0
Buses	0	4	0	4	0	0	0	0	2	0	0	2	6
% Buses	0	0.3	0	0.3	0	0	0	0	0.3	0	0	0.3	0.3

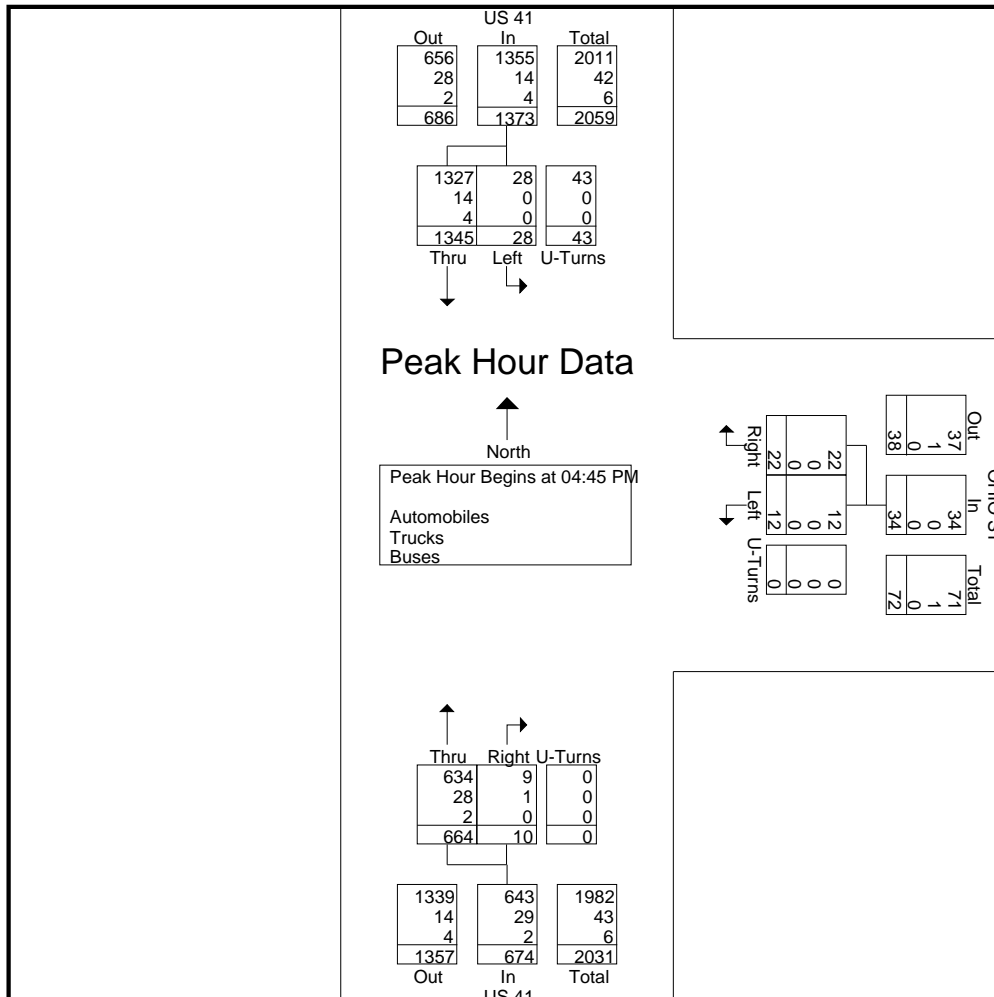



# Southern Traffic Services, Inc.

2911 Westfield Rd  
 Gulf Breeze, FL 32563  
 1-800-786-3374

*Traffic is our only business!*

US 41 @ Ohio St  
 Tampa, FL

File Name : 13015-2 us 41 @ ohio st  
 Site Code : 13015-2  
 Start Date : 1/10/2013  
 Page No : 1

Groups Printed- Automobiles

Start Time	US 41 Southbound			OHIO ST Westbound			US 41 Northbound			Int. Total
	Left	Thru	U-Turns	Left	Right	U-Turns	Thru	Right	U-Turns	
07:00 AM	4	129	3	4	4	0	324	3	2	473
07:15 AM	7	128	3	2	6	0	345	4	0	495
07:30 AM	4	178	8	3	1	0	386	3	0	583
07:45 AM	5	145	4	5	2	0	290	2	0	453
Total	20	580	18	14	13	0	1345	12	2	2004
08:00 AM	4	81	0	0	2	0	282	2	0	371
08:15 AM	6	120	2	2	7	0	224	0	0	361
08:30 AM	5	103	2	1	3	0	176	2	1	293
08:45 AM	6	63	4	1	0	0	164	1	0	239
Total	21	367	8	4	12	0	846	5	1	1264
**BREAK**										
04:00 PM	10	255	6	5	4	0	150	1	0	431
04:15 PM	7	273	15	5	5	0	139	0	0	444
04:30 PM	4	253	6	3	2	0	157	4	0	429
04:45 PM	9	295	7	3	5	0	154	2	0	475
Total	30	1076	34	16	16	0	600	7	0	1779
05:00 PM	5	320	7	2	7	0	173	2	0	516
05:15 PM	7	341	16	3	5	0	154	2	0	528
05:30 PM	7	371	13	4	5	0	153	3	0	556
05:45 PM	7	292	7	2	3	0	133	2	0	446
Total	26	1324	43	11	20	0	613	9	0	2046
Grand Total	97	3347	103	45	61	0	3404	33	3	7093
Apprch %	2.7	94.4	2.9	42.5	57.5	0	99	1	0.1	
Total %	1.4	47.2	1.5	0.6	0.9	0	48	0.5	0	





# Southern Traffic Services, Inc.

2911 Westfield Rd  
Gulf Breeze, FL 32563  
1-800-786-3374

*Traffic is our only business!*

US 41 @ Ohio St  
Tampa, FL

File Name : 13015-2 us 41 @ ohio st  
Site Code : 13015-2  
Start Date : 1/10/2013  
Page No : 2

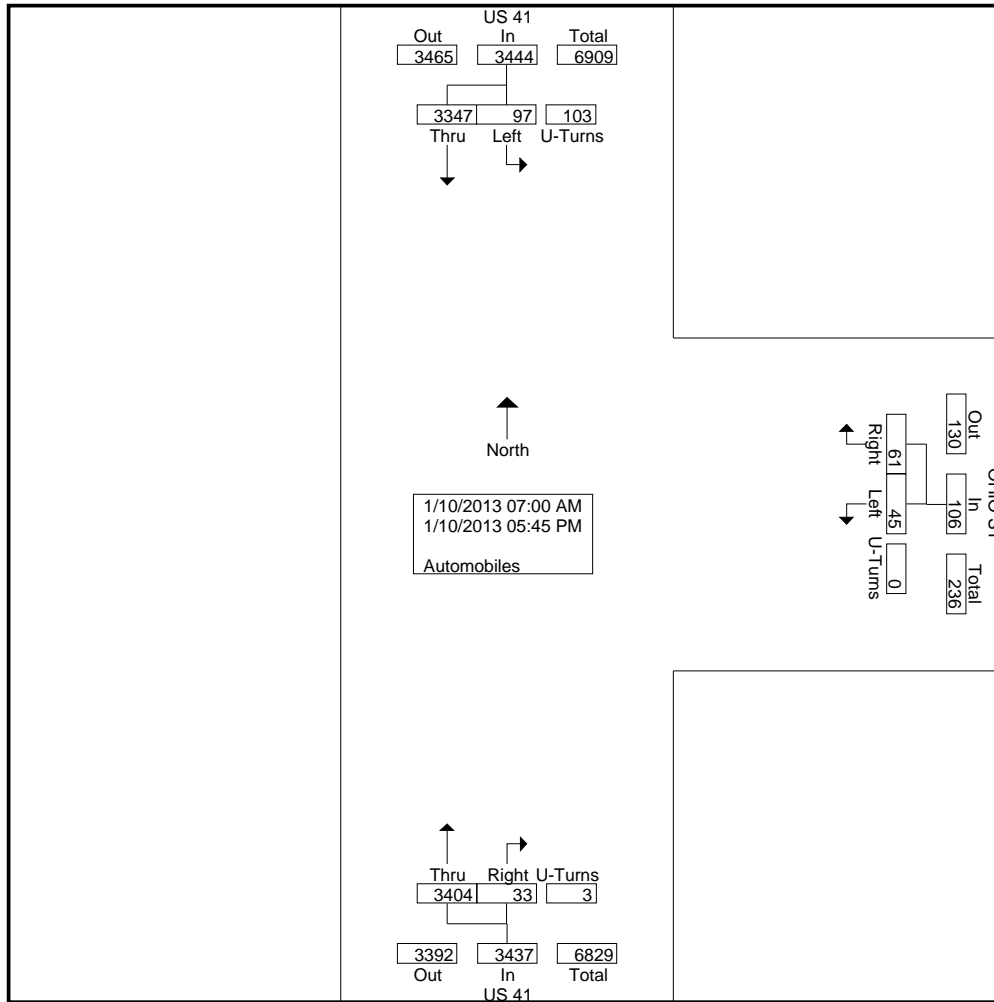



# Southern Traffic Services, Inc.

2911 Westfield Rd  
 Gulf Breeze, FL 32563  
 1-800-786-3374  
*Traffic is our only business!*

US 41 @ Ohio St  
 Tampa, FL

File Name : 13015-2 us 41 @ ohio st  
 Site Code : 13015-2  
 Start Date : 1/10/2013  
 Page No : 3

Start Time	US 41 Southbound				OHIO ST Westbound				US 41 Northbound				Int. Total
	Left	Thru	U-Turns	App. Total	Left	Right	U-Turns	App. Total	Thru	Right	U-Turns	App. Total	
Peak Hour Analysis From 07:00 AM to 11:45 AM - Peak 1 of 1													
Peak Hour for Entire Intersection Begins at 07:00 AM													
07:00 AM	4	129	3	136	4	4	0	8	324	3	2	329	473
07:15 AM	7	128	3	138	2	6	0	8	345	4	0	349	495
07:30 AM	4	178	8	190	3	1	0	4	386	3	0	389	583
07:45 AM	5	145	4	154	5	2	0	7	290	2	0	292	453
Total Volume	20	580	18	618	14	13	0	27	1345	12	2	1359	2004
% App. Total	3.2	93.9	2.9		51.9	48.1	0		99	0.9	0.1		
PHF	.714	.815	.563	.813	.700	.542	.000	.844	.871	.750	.250	.873	.859

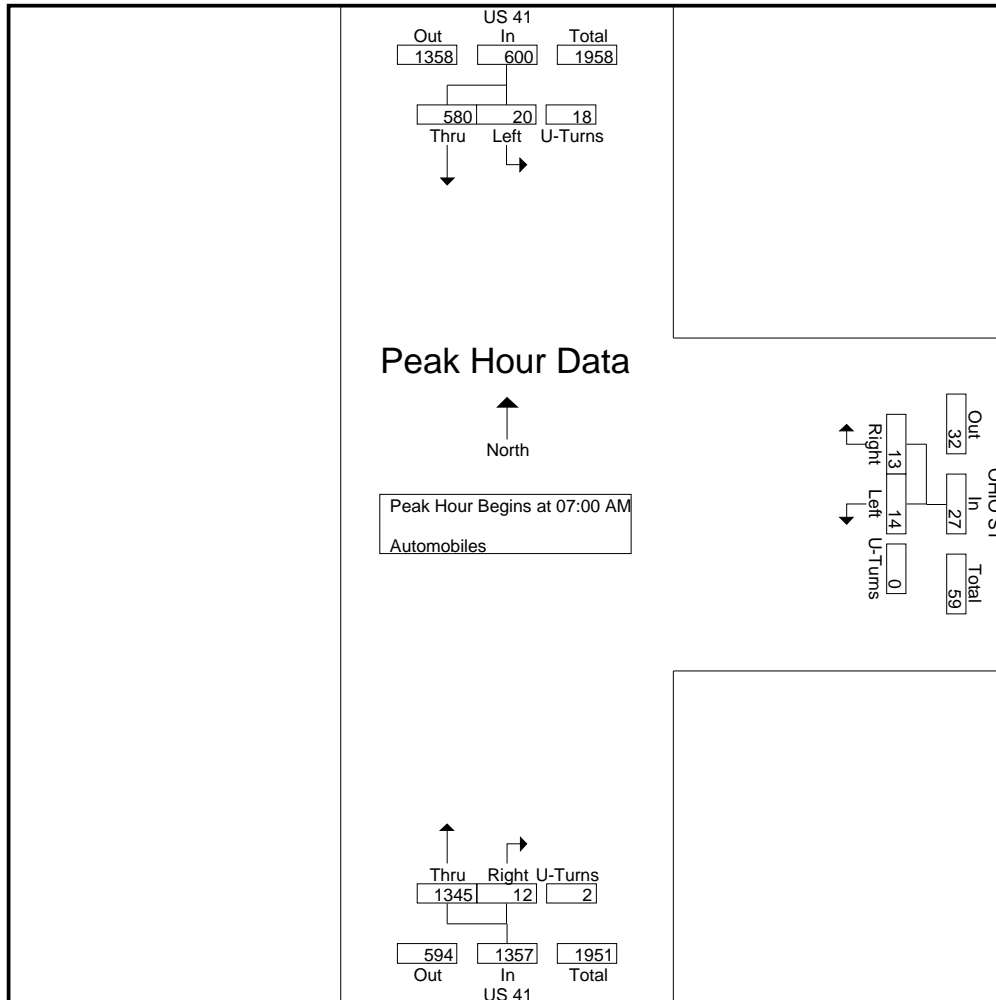



# Southern Traffic Services, Inc.

2911 Westfield Rd  
 Gulf Breeze, FL 32563  
 1-800-786-3374

*Traffic is our only business!*

US 41 @ Ohio St  
 Tampa, FL

File Name : 13015-2 us 41 @ ohio st  
 Site Code : 13015-2  
 Start Date : 1/10/2013  
 Page No : 4

Start Time	US 41 Southbound				OHIO ST Westbound				US 41 Northbound				Int. Total
	Left	Thru	U-Turns	App. Total	Left	Right	U-Turns	App. Total	Thru	Right	U-Turns	App. Total	
Peak Hour Analysis From 12:00 PM to 05:45 PM - Peak 1 of 1													
Peak Hour for Entire Intersection Begins at 04:45 PM													
04:45 PM	9	295	7	311	3	5	0	8	154	2	0	156	475
05:00 PM	5	320	7	332	2	7	0	9	173	2	0	175	516
05:15 PM	7	341	16	364	3	5	0	8	154	2	0	156	528
05:30 PM	7	371	13	391	4	5	0	9	153	3	0	156	556
Total Volume	28	1327	43	1398	12	22	0	34	634	9	0	643	2075
% App. Total	2	94.9	3.1		35.3	64.7	0		98.6	1.4	0		
PHF	.778	.894	.672	.894	.750	.786	.000	.944	.916	.750	.000	.919	.933

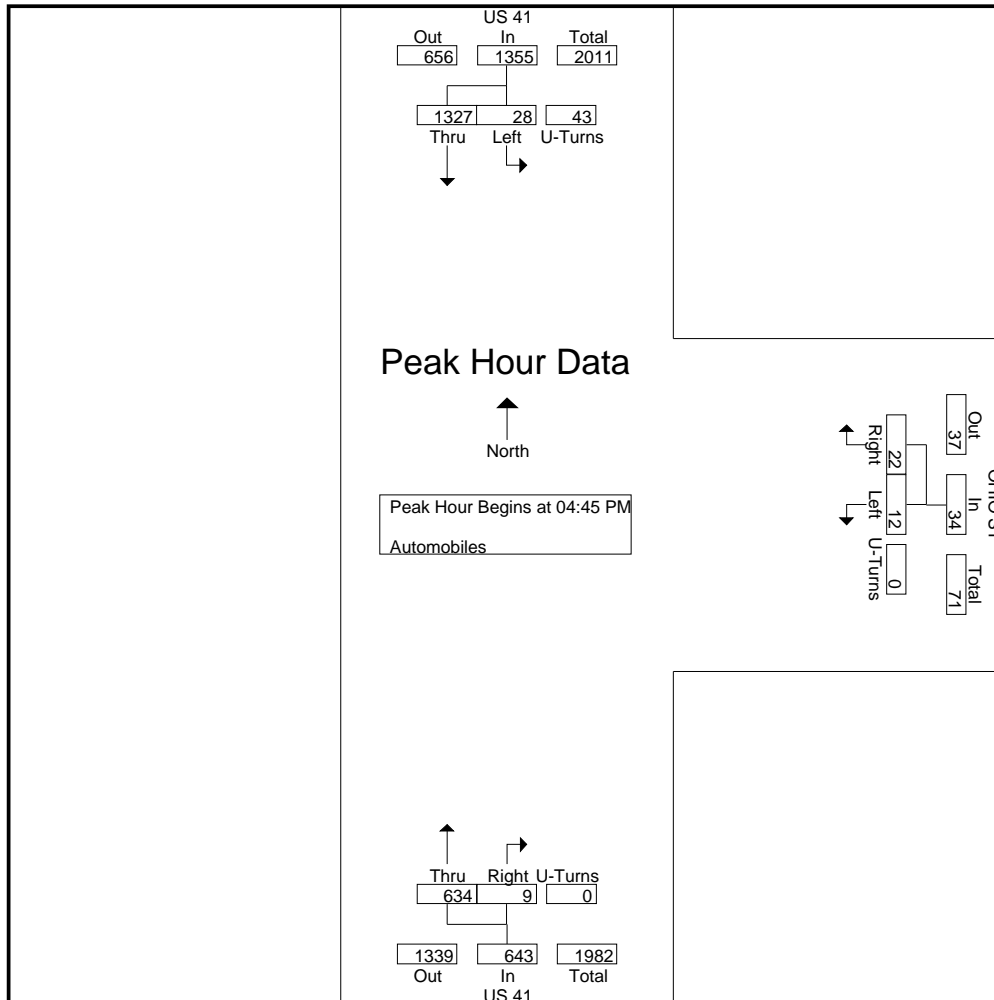



# Southern Traffic Services, Inc.

2911 Westfield Rd  
Gulf Breeze, FL 32563  
1-800-786-3374

*Traffic is our only business!*

US 41 @ Ohio St  
Tampa, FL

File Name : 13015-2 us 41 @ ohio st  
Site Code : 13015-2  
Start Date : 1/10/2013  
Page No : 1

Groups Printed- Trucks - Buses

Start Time	US 41 Southbound			OHIO ST Westbound			US 41 Northbound			Int. Total
	Left	Thru	U-Turns	Left	Right	U-Turns	Thru	Right	U-Turns	
07:00 AM	0	18	0	0	2	0	6	0	0	26
07:15 AM	5	11	0	0	1	0	7	0	0	24
07:30 AM	0	17	0	1	0	0	4	1	0	23
07:45 AM	0	11	0	1	0	0	5	0	0	17
<b>Total</b>	<b>5</b>	<b>57</b>	<b>0</b>	<b>2</b>	<b>3</b>	<b>0</b>	<b>22</b>	<b>1</b>	<b>0</b>	<b>90</b>
08:00 AM	0	7	0	0	0	0	10	0	0	17
08:15 AM	0	12	1	0	0	0	9	1	0	23
08:30 AM	1	16	0	0	0	0	7	0	0	24
08:45 AM	0	6	0	0	0	0	7	1	0	14
<b>Total</b>	<b>1</b>	<b>41</b>	<b>1</b>	<b>0</b>	<b>0</b>	<b>0</b>	<b>33</b>	<b>2</b>	<b>0</b>	<b>78</b>
<b>**BREAK**</b>										
04:00 PM	0	7	0	0	0	0	17	0	0	24
04:15 PM	0	12	0	0	0	0	14	2	0	28
04:30 PM	0	6	0	0	0	0	13	0	0	19
04:45 PM	0	5	0	0	0	0	12	1	0	18
<b>Total</b>	<b>0</b>	<b>30</b>	<b>0</b>	<b>0</b>	<b>0</b>	<b>0</b>	<b>56</b>	<b>3</b>	<b>0</b>	<b>89</b>
05:00 PM	0	7	0	0	0	0	5	0	0	12
05:15 PM	0	3	0	0	0	0	5	0	0	8
05:30 PM	0	3	0	0	0	0	8	0	0	11
05:45 PM	0	3	0	0	0	0	3	0	0	6
<b>Total</b>	<b>0</b>	<b>16</b>	<b>0</b>	<b>0</b>	<b>0</b>	<b>0</b>	<b>21</b>	<b>0</b>	<b>0</b>	<b>37</b>
<b>Grand Total</b>	<b>6</b>	<b>144</b>	<b>1</b>	<b>2</b>	<b>3</b>	<b>0</b>	<b>132</b>	<b>6</b>	<b>0</b>	<b>294</b>
Apprch %	4	95.4	0.7	40	60	0	95.7	4.3	0	
Total %	2	49	0.3	0.7	1	0	44.9	2	0	
Trucks	5	119	0	2	1	0	107	4	0	238
% Trucks	83.3	82.6	0	100	33.3	0	81.1	66.7	0	81
Buses	1	25	1	0	2	0	25	2	0	56
% Buses	16.7	17.4	100	0	66.7	0	18.9	33.3	0	19



# Southern Traffic Services, Inc.

2911 Westfield Rd  
 Gulf Breeze, FL 32563  
 1-800-786-3374

*Traffic is our only business!*

US 41 @ Ohio St  
 Tampa, FL

File Name : 13015-2 us 41 @ ohio st  
 Site Code : 13015-2  
 Start Date : 1/10/2013  
 Page No : 2

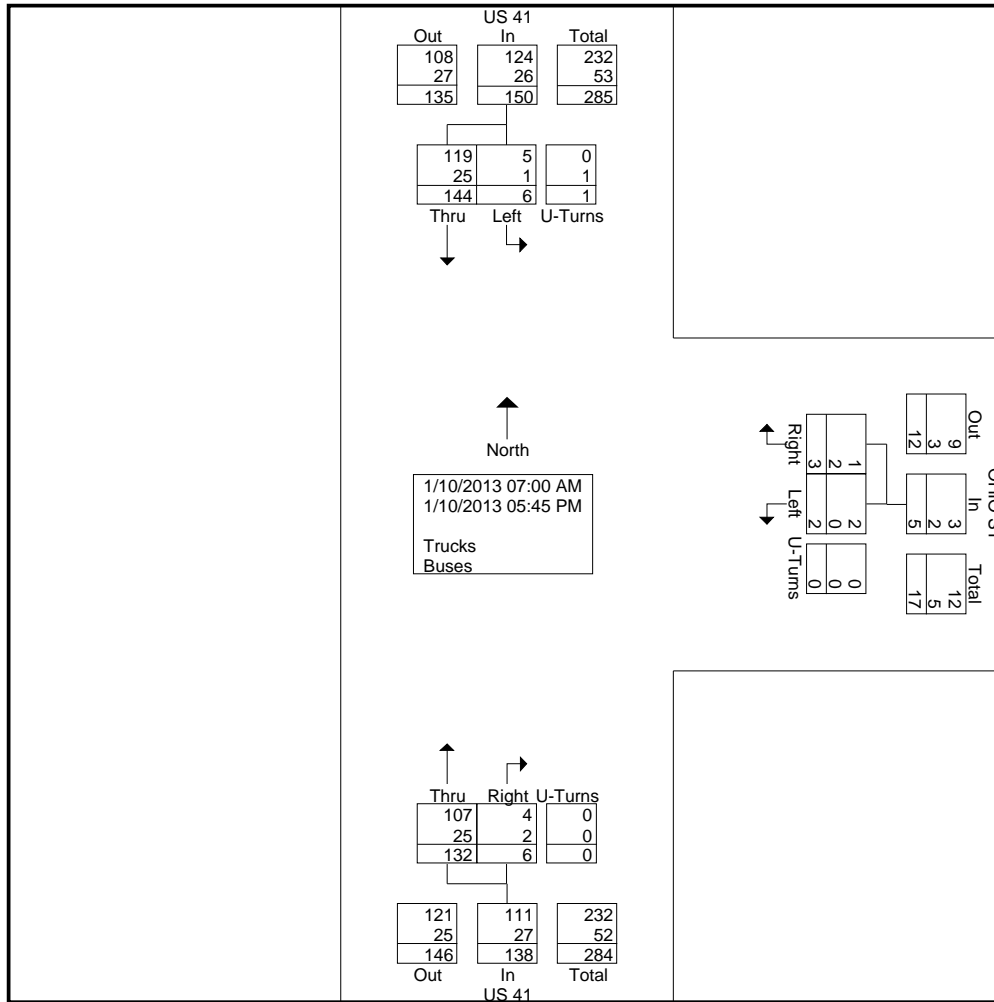



# Southern Traffic Services, Inc.

2911 Westfield Rd  
Gulf Breeze, FL 32563  
1-800-786-3374

*Traffic is our only business!*

US 41 @ Ohio St  
Tampa, FL

File Name : 13015-2 us 41 @ ohio st  
Site Code : 13015-2  
Start Date : 1/10/2013  
Page No : 3

Start Time	US 41 Southbound				OHIO ST Westbound				US 41 Northbound				Int. Total
	Left	Thru	U-Turns	App. Total	Left	Right	U-Turns	App. Total	Thru	Right	U-Turns	App. Total	
Peak Hour Analysis From 07:00 AM to 11:45 AM - Peak 1 of 1													
Peak Hour for Entire Intersection Begins at 07:00 AM													
07:00 AM	0	18	0	18	0	2	0	2	6	0	0	6	26
07:15 AM	5	11	0	16	0	1	0	1	7	0	0	7	24
07:30 AM	0	17	0	17	1	0	0	1	4	1	0	5	23
07:45 AM	0	11	0	11	1	0	0	1	5	0	0	5	17
Total Volume	5	57	0	62	2	3	0	5	22	1	0	23	90
% App. Total	8.1	91.9	0		40	60	0		95.7	4.3	0		
PHF	.250	.792	.000	.861	.500	.375	.000	.625	.786	.250	.000	.821	.865

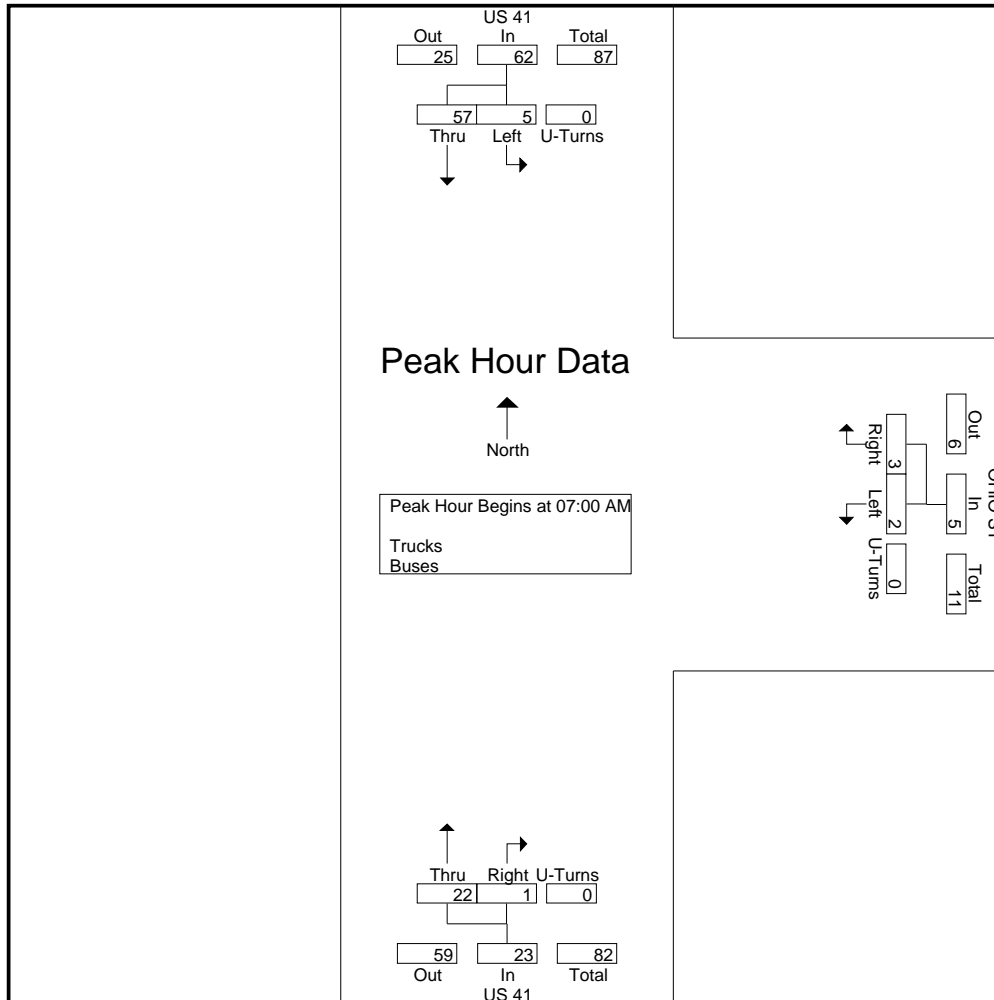



# Southern Traffic Services, Inc.

2911 Westfield Rd  
Gulf Breeze, FL 32563  
1-800-786-3374

*Traffic is our only business!*

US 41 @ Ohio St  
Tampa, FL

File Name : 13015-2 us 41 @ ohio st  
Site Code : 13015-2  
Start Date : 1/10/2013  
Page No : 4

Start Time	US 41 Southbound				OHIO ST Westbound				US 41 Northbound				Int. Total
	Left	Thru	U-Turns	App. Total	Left	Right	U-Turns	App. Total	Thru	Right	U-Turns	App. Total	
Peak Hour Analysis From 12:00 PM to 05:45 PM - Peak 1 of 1													
Peak Hour for Entire Intersection Begins at 04:00 PM													
04:00 PM	0	7	0	7	0	0	0	0	17	0	0	17	24
04:15 PM	0	12	0	12	0	0	0	0	14	2	0	16	28
04:30 PM	0	6	0	6	0	0	0	0	13	0	0	13	19
04:45 PM	0	5	0	5	0	0	0	0	12	1	0	13	18
Total Volume	0	30	0	30	0	0	0	0	56	3	0	59	89
% App. Total	0	100	0		0	0	0		94.9	5.1	0		
PHF	.000	.625	.000	.625	.000	.000	.000	.000	.824	.375	.000	.868	.795

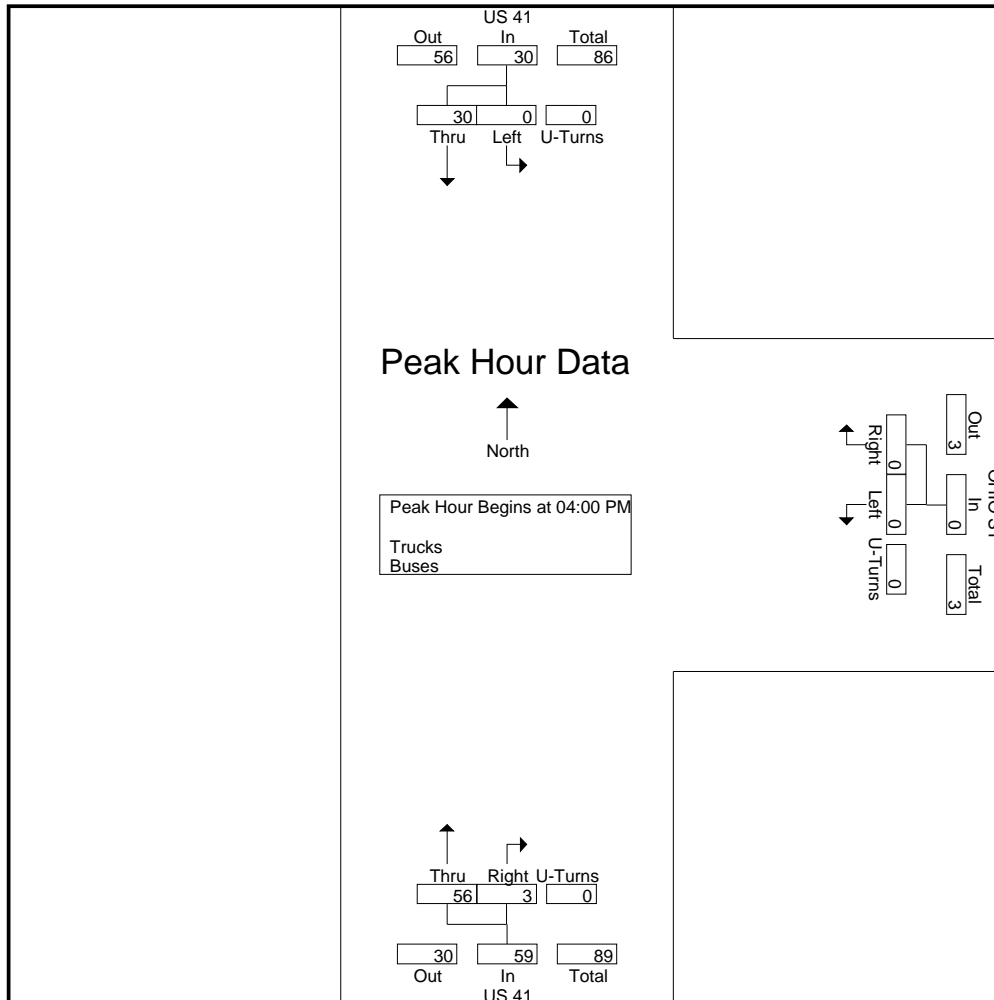



# Southern Traffic Services, Inc.

2911 Westfield Rd  
Gulf Breeze, FL 32563  
1-800-786-3374

*Traffic is our only business!*

US 41 @ Ohio St  
Tampa, FL

File Name : 13015-2 US 41 @ Ohio St Peds  
Site Code : 13015-2  
Start Date : 1/10/2013  
Page No : 1

Groups Printed- Peds

Start Time	US 41	OHIO ST	US 41	Int. Total
	Southbound	Westbound	Northbound	
	Peds	Peds	Peds	
07:00 AM	0	0	0	0
07:15 AM	0	0	0	0
07:30 AM	0	0	0	0
07:45 AM	0	0	0	0
Total	0	0	0	0
08:00 AM	0	0	0	0
08:15 AM	0	0	0	0
08:30 AM	0	0	0	0
08:45 AM	0	0	0	0
Total	0	0	0	0
09:00 AM	0	0	0	0
09:15 AM	0	0	0	0
09:30 AM	0	0	0	0
09:45 AM	0	0	0	0
Total	0	0	0	0
10:00 AM	0	0	0	0
10:15 AM	0	0	0	0
10:30 AM	0	0	0	0
10:45 AM	0	0	0	0
Total	0	0	0	0
11:00 AM	0	0	0	0
11:15 AM	0	0	0	0
11:30 AM	0	0	0	0
11:45 AM	0	0	0	0
Total	0	0	0	0
12:00 PM	0	0	0	0
12:15 PM	0	0	0	0
12:30 PM	0	0	0	0
12:45 PM	0	0	0	0
Total	0	0	0	0
01:00 PM	0	0	0	0
01:15 PM	0	0	0	0
01:30 PM	0	0	0	0
01:45 PM	0	0	0	0
Total	0	0	0	0
02:00 PM	0	0	0	0
02:15 PM	0	0	0	0
02:30 PM	0	0	0	0
02:45 PM	0	0	0	0
Total	0	0	0	0
03:00 PM	0	0	0	0
03:15 PM	0	0	0	0
03:30 PM	0	0	0	0
03:45 PM	0	0	0	0
Total	0	0	0	0





# Southern Traffic Services, Inc.

2911 Westfield Rd  
 Gulf Breeze, FL 32563  
 1-800-786-3374

*Traffic is our only business!*

US 41 @ Ohio St  
 Tampa, FL

File Name : 13015-2 US 41 @ Ohio St Peds  
 Site Code : 13015-2  
 Start Date : 1/10/2013  
 Page No : 2

Groups Printed- Peds

Start Time	US 41 Southbound	OHIO ST Westbound	US 41 Northbound	Int. Total
	Peds	Peds	Peds	
04:00 PM	0	0	0	0
04:15 PM	0	0	0	0
04:30 PM	0	0	0	0
04:45 PM	0	0	0	0
Total	0	0	0	0
05:00 PM	0	0	0	0
05:15 PM	0	0	0	0
05:30 PM	0	0	0	0
05:45 PM	0	0	0	0
Total	0	0	0	0
Grand Total	0	0	0	0
Apprch %	0	0	0	0
Total %	0	0	0	0

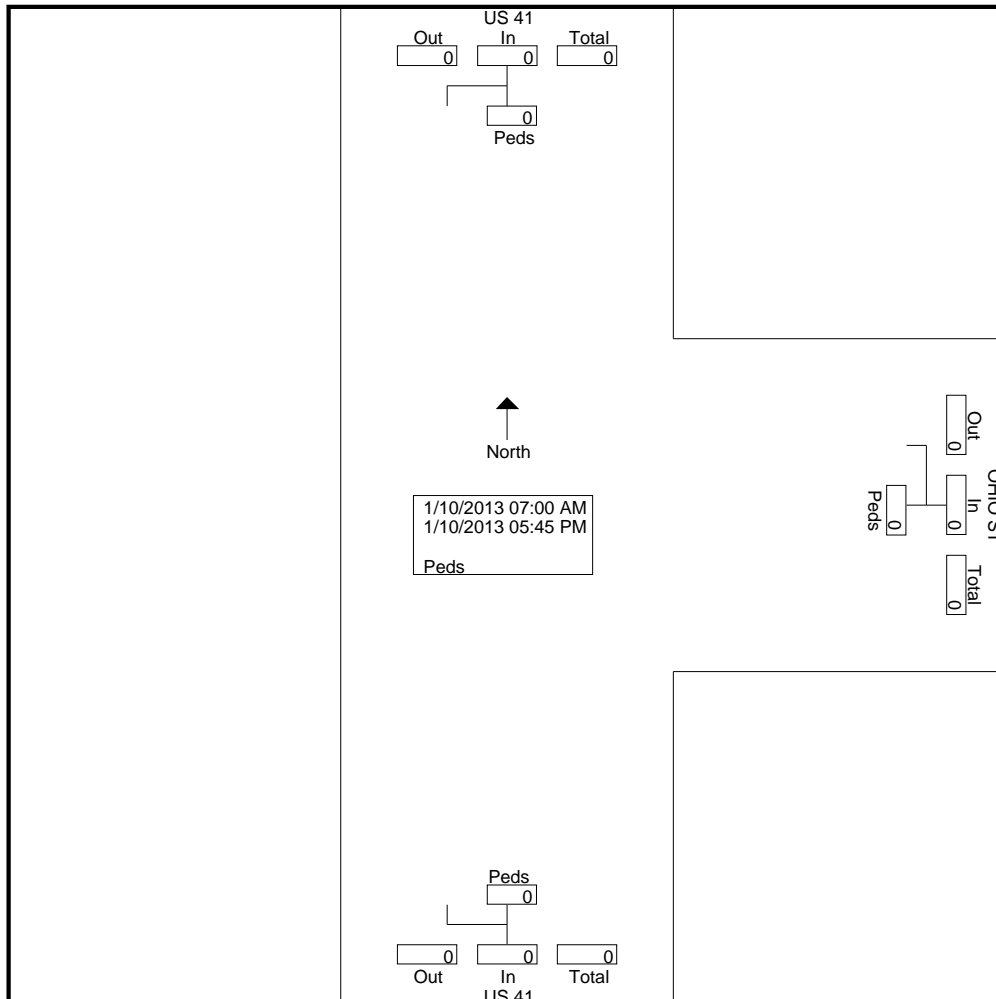

# Southern Traffic Services, Inc.

## Event Counts

**US 41 north of Ohio Street**

**Northbound**

**Datasets:**

**Site:** [021] !C1109  
**Input A:** 7 - North bound A>B, South bound B>A. - Excluded from totals. (0)  
**Input B:** 0 - Unused or unknown. - Added to totals. (1)  
**Survey Duration:** 14:26 Monday, January 07, 2013 => 20:42 Friday, January 11, 2013  
**File:** G:\DATA\2013\Private\13015\brandon\machine data 1-7-13\UM021.eco (Plus)  
**Identifier:** CV65Z9Q0 MC56-L5 [MC55] (c)Microcom 19Oct04  
**Algorithm:** Event Count  
**Data type:** Axle sensors - Paired (Class, Speed, Count)

**Profile:**

**Filter time:** 0:00 Tuesday, January 08, 2013 => 0:00 Friday, January 11, 2013  
**Name:** Factory default profile  
**Scheme:** Count events divided by two.  
**Units:** Non metric (ft, mi, ft/s, mph, lb, ton)  
**In profile:** Events = 37233

**Tuesday, January 08, 2013=12612, 15 minute drops**

0000	0100	0200	0300	0400	0500	0600	0700	0800	0900	1000	1100	1200	1300	1400	1500	1600	1700	1800	1900	2000	2100	2200	2300	
48	37	22	53	130	472	1269	1539	1018	704	609	634	671	660	774	840	788	798	522	319	252	213	138	102	
11	12	7	16	15	82	241	339	289	142	152	169	149	160	163	195	189	200	148	88	47	60	35	30	18
12	11	4	11	24	105	299	405	289	210	154	165	170	171	214	204	177	207	164	100	62	49	38	32	23
17	6	4	14	41	124	293	432	230	187	151	146	176	175	219	231	215	221	122	77	72	50	34	28	28
8	8	7	12	50	161	436	363	210	165	152	154	176	154	178	210	207	170	88	54	71	54	31	12	12

AM Peak 0645 - 0745 (1612), AM PHF=0.92 PM Peak 1500 - 1600 (840), PM PHF=0.91

**Wednesday, January 09, 2013=12392, 15 minute drops**

0000	0100	0200	0300	0400	0500	0600	0700	0800	0900	1000	1100	1200	1300	1400	1500	1600	1700	1800	1900	2000	2100	2200	2300	
81	37	43	57	125	498	1092	1423	939	707	633	597	657	654	760	840	786	811	582	328	263	243	143	93	
18	7	12	15	15	84	192	321	299	186	157	148	152	192	193	194	189	218	173	115	59	82	48	31	18
23	12	9	18	36	95	269	343	251	170	154	147	172	155	202	187	197	221	148	79	90	62	33	19	14
28	11	13	13	31	145	271	423	210	167	168	150	164	156	190	246	216	204	123	74	58	49	33	20	11
12	7	9	11	43	174	360	336	179	184	154	152	169	151	175	213	184	168	138	60	56	50	29	23	12

AM Peak 0645 - 0745 (1447), AM PHF=0.86 PM Peak 1530 - 1630 (845), PM PHF=0.86

**Thursday, January 10, 2013=12229, 15 minute drops**

0000	0100	0200	0300	0400	0500	0600	0700	0800	0900	1000	1100	1200	1300	1400	1500	1600	1700	1800	1900	2000	2100	2200	2300	
55	43	28	50	131	464	1072	1439	932	643	590	649	618	654	755	872	762	739	594	341	318	241	150	89	
18	11	7	13	20	77	199	336	284	165	149	153	144	147	170	170	177	186	182	86	67	59	33	23	16
14	9	9	16	32	92	225	322	265	166	164	177	157	167	211	207	202	205	155	105	91	75	40	17	21
11	15	6	10	37	127	342	448	202	174	33	156	156	162	214	276	194	183	138	75	77	54	40	31	10
12	8	6	11	42	168	306	333	181	138	244	163	161	178	160	219	189	165	119	75	83	53	37	18	14

AM Peak 0700 - 0800 (1439), AM PHF=0.80 PM Peak 1515 - 1615 (879), PM PHF=0.80

# Southern Traffic Services, Inc.

## Event Counts

US 41 north of Ohio Street

Southbound

**Datasets:**

**Site:** [021] !C1109  
**Input A:** 7 - North bound A>B, South bound B>A. - Added to totals. (1)  
**Input B:** 0 - Unused or unknown. - Excluded from totals. (0)  
**Survey Duration:** 14:26 Monday, January 07, 2013 => 20:42 Friday, January 11, 2013  
**File:** G:\DATA\2013\Private\13015\brandon\machine data 1-7-13\UM021.eco (Plus)  
**Identifier:** CV65Z9Q0 MC56-L5 [MC55] (c)Microcom 19Oct04  
**Algorithm:** Event Count  
**Data type:** Axle sensors - Paired (Class, Speed, Count)

**Profile:**

**Filter time:** 0:00 Tuesday, January 08, 2013 => 0:00 Friday, January 11, 2013  
**Name:** Factory default profile  
**Scheme:** Count events divided by two.  
**Units:** Non metric (ft, mi, ft/s, mph, lb, ton)  
**In profile:** Events = 36035

**Tuesday, January 08, 2013=12004, 15 minute drops**

0000	0100	0200	0300	0400	0500	0600	0700	0800	0900	1000	1100	1200	1300	1400	1500	1600	1700	1800	1900	2000	2100	2200	2300	
121	51	39	57	97	209	565	700	566	536	503	592	610	623	625	913	1167	1359	1037	545	412	292	246	139	
34	14	7	13	13	27	102	158	138	115	113	131	163	136	154	115	276	313	306	159	118	69	76	36	25
61	13	6	13	20	37	159	178	147	154	135	149	164	121	171	250	274	361	297	133	117	72	77	39	31
19	10	15	14	31	73	119	198	153	133	114	175	122	204	147	256	298	355	241	112	88	74	52	38	13
7	14	11	17	33	72	185	166	128	134	141	137	161	162	153	292	319	330	193	141	89	77	41	26	8

AM Peak 0645 - 0745 (719), AM PHF=0.91 PM Peak 1700 - 1800 (1359), PM PHF=0.94

**Wednesday, January 09, 2013=12073, 15 minute drops**

0000	0100	0200	0300	0400	0500	0600	0700	0800	0900	1000	1100	1200	1300	1400	1500	1600	1700	1800	1900	2000	2100	2200	2300	
77	56	52	41	71	245	576	709	600	515	545	533	605	593	707	904	1197	1355	970	545	425	346	261	145	
25	13	12	5	11	17	113	161	143	129	145	132	126	149	170	177	305	301	319	147	109	89	77	41	33
31	14	16	18	20	40	127	158	142	136	134	139	162	143	174	198	275	375	260	116	117	96	61	34	15
13	19	15	11	12	83	175	212	157	107	125	147	150	141	152	275	296	326	219	175	104	86	69	43	31
8	10	9	7	28	105	161	178	158	143	141	115	167	160	211	254	321	353	172	107	95	75	54	27	21

AM Peak 0700 - 0800 (709), AM PHF=0.84 PM Peak 1715 - 1815 (1373), PM PHF=0.92

**Thursday, January 10, 2013=11958, 15 minute drops**

0000	0100	0200	0300	0400	0500	0600	0700	0800	0900	1000	1100	1200	1300	1400	1500	1600	1700	1800	1900	2000	2100	2200	2300	
100	61	50	36	80	221	560	734	487	518	489	558	581	600	720	917	1142	1389	959	598	431	311	246	170	
33	17	9	7	15	35	113	166	107	129	119	155	153	138	150	205	278	328	267	196	128	80	52	19	32
15	10	15	10	20	40	166	174	140	131	106	128	145	160	199	210	287	339	248	164	107	91	63	67	35
31	18	18	11	19	54	148	204	143	136	125	124	148	89	163	231	281	399	236	136	101	66	67	40	27
21	16	8	8	26	92	133	190	97	122	139	151	135	213	208	271	296	323	208	102	95	74	64	44	18

AM Peak 0700 - 0800 (734), AM PHF=0.90 PM Peak 1700 - 1800 (1389), PM PHF=0.87

# Southern Traffic Services, Inc.

## Event Counts

US 41 south of Ohio Street

Northbound

**Datasets:**

**Site:** [022] !c9110  
**Input A:** 1 - North bound, A hit first. - Added to totals. (1)  
**Input B:** 0 - Unused or unknown. - Excluded from totals. (0)  
**Survey Duration:** 10:16 Monday, January 07, 2013 => 20:36 Friday, January 11, 2013  
**File:** G:\DATA\2013\Private\13015\brandon\machine data 1-7-13\UM022 NB.eco (Plus)  
**Identifier:** AE539XVG MC56-L5 [MC55] (c)Microcom 19Oct04  
**Algorithm:** Event Count  
**Data type:** Axle sensors - Paired (Class, Speed, Count)

**Profile:**

**Filter time:** 0:00 Tuesday, January 08, 2013 => 0:00 Friday, January 11, 2013  
**Name:** Factory default profile  
**Scheme:** Count events divided by two.  
**Units:** Non metric (ft, mi, ft/s, mph, lb, ton)  
**In profile:** Events = 36728

**Tuesday, January 08, 2013=12452, 15 minute drops**

0000	0100	0200	0300	0400	0500	0600	0700	0800	0900	1000	1100	1200	1300	1400	1500	1600	1700	1800	1900	2000	2100	2200	2300	
45	38	27	69	145	492	1303	1646	1080	724	589	614	637	651	770	819	729	740	475	266	207	183	118	85	
8	11	8	19	19	88	253	383	315	163	144	168	144	154	161	193	167	183	138	84	37	54	29	23	20
12	11	6	19	23	105	297	434	311	212	156	165	162	183	212	207	156	191	154	85	51	50	32	28	21
16	7	5	18	42	133	325	432	228	187	149	140	161	156	226	218	201	204	106	59	57	41	28	23	17
9	9	8	13	61	166	428	397	226	162	140	141	170	158	171	201	205	162	77	38	62	38	29	11	12

AM Peak 0645 - 0745 (1677), AM PHF=0.97 PM Peak 1500 - 1600 (819), PM PHF=0.94

**Wednesday, January 09, 2013=12165, 15 minute drops**

0000	0100	0200	0300	0400	0500	0600	0700	0800	0900	1000	1100	1200	1300	1400	1500	1600	1700	1800	1900	2000	2100	2200	2300	
70	26	41	60	127	509	1109	1436	930	717	631	577	645	666	741	811	778	782	543	294	227	232	126	87	
20	7	13	17	15	80	186	321	299	194	158	132	146	202	179	189	185	219	161	105	48	83	40	32	13
21	5	6	17	31	102	278	359	246	174	154	147	166	153	216	163	206	207	141	72	81	56	26	14	15
17	9	15	13	37	140	272	412	210	171	169	140	159	150	177	244	212	200	118	57	53	43	32	19	4
12	5	7	13	44	187	373	344	175	178	150	158	174	161	169	215	175	156	123	60	45	50	28	22	9

AM Peak 0645 - 0745 (1465), AM PHF=0.89 PM Peak 1530 - 1630 (850), PM PHF=0.87

**Thursday, January 10, 2013=12111, 15 minute drops**

0000	0100	0200	0300	0400	0500	0600	0700	0800	0900	1000	1100	1200	1300	1400	1500	1600	1700	1800	1900	2000	2100	2200	2300	
41	41	28	43	127	470	1163	1472	939	645	608	624	609	643	781	864	742	705	569	305	279	200	134	79	
13	8	7	11	20	78	187	352	295	169	150	143	141	148	169	170	176	175	179	71	59	56	29	21	13
15	9	8	13	27	93	229	366	262	167	171	177	158	161	229	214	180	190	146	97	91	61	34	18	18
4	13	7	11	36	127	354	417	202	179	23	156	162	162	236	263	198	177	124	65	63	40	42	27	10
9	11	6	8	44	172	393	337	180	130	264	148	148	172	147	217	188	163	120	72	66	43	29	13	15

AM Peak 0645 - 0745 (1528), AM PHF=0.92 PM Peak 1515 - 1615 (870), PM PHF=0.83

# Southern Traffic Services, Inc.

## Event Counts

US 41 south of Ohio Street

Southbound

**Datasets:**

**Site:** [022] !C6115  
**Input A:** 3 - South bound, A hit first. - Added to totals. (1)  
**Input B:** 0 - Unused or unknown. - Excluded from totals. (0)  
**Survey Duration:** 14:23 Monday, January 07, 2013 => 20:34 Friday, January 11, 2013  
**File:** G:\DATA\2013\Private\13015\brandon\machine data 1-7-13\UM022 SB.eco (Plus)  
**Identifier:** 1114HJ0S MC56-6 [MC55] (c)Microcom 02/03/01  
**Algorithm:** Event Count  
**Data type:** Axle sensors - Paired (Class, Speed, Count)

**Profile:**

**Filter time:** 0:00 Tuesday, January 08, 2013 => 0:00 Friday, January 11, 2013  
**Name:** Factory default profile  
**Scheme:** Count events divided by two.  
**Units:** Non metric (ft, mi, ft/s, mph, lb, ton)  
**In profile:** Events = 34357

**Tuesday, January 08, 2013=11413, 15 minute drops**

0000	0100	0200	0300	0400	0500	0600	0700	0800	0900	1000	1100	1200	1300	1400	1500	1600	1700	1800	1900	2000	2100	2200	2300	
117	48	38	53	96	199	553	693	549	504	481	561	571	589	592	860	1120	1298	999	502	381	269	216	124	
32	13	7	11	15	24	97	159	130	111	108	124	155	128	145	108	255	290	301	151	114	64	72	32	24
61	11	6	12	20	34	157	177	143	149	128	146	158	116	163	238	261	355	282	123	104	69	69	34	21
17	10	15	13	27	68	115	194	149	118	113	158	108	190	147	236	290	349	233	101	77	62	45	32	9
7	14	10	17	34	73	184	163	127	126	132	133	150	155	137	278	314	304	183	127	86	74	30	26	8

AM Peak 0645 - 0745 (714), AM PHF=0.92 PM Peak 1715 - 1815 (1309), PM PHF=0.92

**Wednesday, January 09, 2013=11552, 15 minute drops**

0000	0100	0200	0300	0400	0500	0600	0700	0800	0900	1000	1100	1200	1300	1400	1500	1600	1700	1800	1900	2000	2100	2200	2300	
62	50	47	37	71	238	554	685	582	499	521	505	586	575	650	860	1172	1317	929	509	395	331	245	132	
24	12	14	4	13	17	111	159	144	126	139	125	124	140	149	158	303	293	306	139	105	82	71	36	29
21	11	13	17	19	38	118	154	136	135	129	132	156	136	157	184	271	359	246	106	101	91	57	30	16
9	14	13	8	10	77	167	204	150	105	129	138	141	140	148	267	291	321	210	165	103	86	64	41	26
8	13	7	8	29	106	158	168	152	133	124	110	165	159	196	251	307	344	167	99	86	72	53	25	20

AM Peak 0700 - 0800 (685), AM PHF=0.84 PM Peak 1715 - 1815 (1330), PM PHF=0.93

**Thursday, January 10, 2013=11392, 15 minute drops**

0000	0100	0200	0300	0400	0500	0600	0700	0800	0900	1000	1100	1200	1300	1400	1500	1600	1700	1800	1900	2000	2100	2200	2300	
91	57	46	31	77	213	545	729	460	511	457	525	555	580	671	882	1101	1344	917	551	396	265	229	159	
29	15	9	6	16	34	104	169	101	118	108	152	153	137	144	197	264	323	256	184	118	76	47	17	29
16	8	12	8	16	30	156	167	131	132	97	119	139	148	185	206	273	322	237	151	101	75	56	69	34
26	18	17	11	18	53	153	191	141	138	119	116	140	89	151	216	275	387	226	122	88	48	66	34	25
20	16	8	6	27	96	132	202	87	123	133	138	123	206	191	263	289	312	198	94	89	66	60	39	16

AM Peak 0700 - 0800 (729), AM PHF=0.90 PM Peak 1700 - 1800 (1344), PM PHF=0.87

# MetroCount Traffic Executive Event Counts

**Ohio St e/o US 41** Eastbound

**Datasets:**

**Site:** [023] I5094  
**Input A:** 6 - West bound A>B, East bound B>A. - Added to totals. (1)  
**Input B:** 0 - Unused or unknown. - Subtracted from totals. (-1)  
**Survey Duration:** 14:24 Monday, January 07, 2013 => 20:45 Friday, January 11, 2013  
**File:** G:\DATA\2013\Private\13015\brandon\machine data 1-7-13\UM023.eco (Plus)  
**Identifier:** Q968X10E MC56-L5 [MC55] (c)Microcom 19Oct04  
**Algorithm:** Event Count  
**Data type:** Axle sensors - Paired (Class, Speed, Count)

**Profile:**

**Filter time:** 0:00 Tuesday, January 08, 2013 => 0:00 Friday, January 11, 2013  
**Name:** Factory default profile  
**Scheme:** Count events divided by two.  
**Units:** Non metric (ft, mi, ft/s, mph, lb, ton)  
**In profile:** Events = 2383

**Tuesday, January 08, 2013=878, 15 minute drops**

0000	0100	0200	0300	0400	0500	0600	0700	0800	0900	1000	1100	1200	1300	1400	1500	1600	1700	1800	1900	2000	2100	2200	2300	
0	0	0	12	1	12	35	47	66	83	49	68	62	64	64	75	62	62	46	29	19	9	6	7	
0	0	0	7	0	7	6	10	14	12	14	13	10	15	21	15	20	20	9	6	1	1	2	2	3
0	0	0	3	0	1	15	3	18	22	9	24	12	10	18	18	24	12	26	7	8	3	1	2	5
0	0	0	2	1	1	4	13	13	28	11	13	18	19	6	22	10	15	9	7	5	4	0	3	1
0	0	0	0	0	3	10	21	21	21	15	18	22	20	19	20	8	15	2	9	5	1	3	0	0

AM Peak 0915 - 1015 (85), AM PHF=0.76 PM Peak 1530 - 1630 (86), PM PHF=0.90

**\* Wednesday, January 09, 2013=809, 15 minute drops**

0000	0100	0200	0300	0400	0500	0600	0700	0800	0900	1000	1100	1200	1300	1400	1500	1600	1700	1800	1900	2000	2100	2200	2300	
9	3	0	5	0	15	51	56	54	59	58	66	47	48	71	84	50	44	32	16	15	8	12	6	
3	0	0	2	0	0	7	8	8	10	13	16	16	18	16	33	9	8	12	3	2	2	3	1	1
5	0	0	1	0	3	10	15	16	18	13	14	9	15	21	24	20	17	6	4	8	3	3	3	0
1	2	0	2	0	4	23	14	18	11	7	21	17	6	15	18	8	6	7	6	4	0	3	2	1
0	1	0	0	0	8	11	19	12	20	25	15	5	9	19	9	13	13	7	3	1	3	3	0	1

AM Peak 1045 - 1145 (76), AM PHF=0.76 PM Peak 1445 - 1545 (94), PM PHF=0.71

**\* Thursday, January 10, 2013=696, 15 minute drops**

0000	0100	0200	0300	0400	0500	0600	0700	0800	0900	1000	1100	1200	1300	1400	1500	1600	1700	1800	1900	2000	2100	2200	2300	
3	2	2	2	1	17	31	40	30	43	50	45	45	46	54	65	40	36	45	29	20	25	20	5	
1	0	0	1	0	1	4	7	6	9	12	12	6	8	13	12	11	7	19	7	5	5	5	0	-
0	0	0	1	0	10	7	18	7	13	5	15	10	16	12	12	10	10	14	9	5	5	8	1	-
1	2	2	0	0	2	10	8	8	8	10	3	10	3	15	27	8	10	5	4	4	8	6	4	-
1	0	0	0	1	4	10	7	9	13	23	15	19	19	14	14	12	9	7	9	6	7	1	0	-

AM Peak 1030 - 1130 (60), AM PHF=0.65 PM Peak 1500 - 1600 (65), PM PHF=0.60

# MetroCount Traffic Executive Event Counts

**Ohio St e/o US 41**

**Westbound**

**Datasets:**

**Site:** [023] I5094  
**Input A:** 6 - West bound A>B, East bound B>A. - Excluded from totals. (0)  
**Input B:** 0 - Unused or unknown. - Added to totals. (1)  
**Survey Duration:** 14:24 Monday, January 07, 2013 => 20:45 Friday, January 11, 2013  
**File:** G:\DATA\2013\Private\13015\brandon\machine data 1-7-13\UM023.eco (Plus)  
**Identifier:** Q968X10E MC56-L5 [MC55] (c)Microcom 19Oct04  
**Algorithm:** Event Count  
**Data type:** Axle sensors - Paired (Class, Speed, Count)

**Profile:**

**Filter time:** 0:00 Tuesday, January 08, 2013 => 0:00 Friday, January 11, 2013  
**Name:** Factory default profile  
**Scheme:** Count events divided by two.  
**Units:** Non metric (ft, mi, ft/s, mph, lb, ton)  
**In profile:** Events = 1620

**Tuesday, January 08, 2013=612, 15 minute drops**

0000	0100	0200	0300	0400	0500	0600	0700	0800	0900	1000	1100	1200	1300	1400	1500	1600	1700	1800	1900	2000	2100	2200	2300
2	1	1	6	2	7	31	38	56	52	36	48	41	37	46	40	48	32	30	19	17	6	11	5
0	1	0	1	0	1	6	11	13	12	11	7	12	6	8	9	14	3	10	2	3	2	4	2
1	0	0	3	1	2	14	7	21	14	11	16	11	9	14	8	13	11	7	7	3	1	3	3
1	0	0	1	0	1	7	4	6	14	5	14	7	10	14	9	8	9	6	7	5	3	0	0
0	0	1	1	1	3	4	16	16	12	9	11	11	12	10	14	13	9	7	3	6	0	4	0

AM Peak 0745 - 0845 (56), AM PHF=0.67 PM Peak 1530 - 1630 (50), PM PHF=0.89

**Wednesday, January 09, 2013=522, 15 minute drops**

0000	0100	0200	0300	0400	0500	0600	0700	0800	0900	1000	1100	1200	1300	1400	1500	1600	1700	1800	1900	2000	2100	2200	2300
3	3	2	4	2	17	34	40	40	45	41	33	32	31	37	38	37	29	18	10	11	5	5	5
1	0	1	0	1	1	7	7	14	10	6	9	9	7	9	5	7	8	6	2	4	1	2	1
2	0	0	2	0	2	7	17	5	15	11	11	7	9	12	13	11	7	4	2	1	0	2	3
0	1	1	1	0	5	9	7	12	10	11	6	12	8	8	12	9	5	4	4	4	1	0	1
0	2	0	1	1	9	11	9	9	10	13	7	4	7	8	8	10	9	4	2	2	3	1	0

AM Peak 0715 - 0815 (47), AM PHF=0.69 PM Peak 1515 - 1615 (40), PM PHF=0.77

**Thursday, January 10, 2013=486, 15 minute drops**

0000	0100	0200	0300	0400	0500	0600	0700	0800	0900	1000	1100	1200	1300	1400	1500	1600	1700	1800	1900	2000	2100	2200	2300
4	1	2	3	4	13	34	33	17	39	24	29	30	39	23	34	33	32	28	19	18	14	10	3
2	1	0	1	0	1	6	10	2	6	5	13	7	9	5	2	9	9	10	5	2	3	6	0
0	0	1	1	3	2	10	10	9	12	5	2	6	8	5	9	11	8	10	8	2	1	1	0
2	0	0	1	0	3	9	5	4	9	8	6	10	10	4	10	5	9	3	1	6	6	2	1
0	0	1	0	1	7	9	8	2	12	6	8	7	12	9	13	8	6	5	5	8	4	1	2

AM Peak 0700 - 0800 (33), AM PHF=0.97 PM Peak 1530 - 1630 (43), PM PHF=0.83







# Southern Traffic Services, Inc.

2911 Westfield Rd  
 Gulf Breeze, FL 32563  
 1-800-786-3374

*Traffic is our only business!*

US 41 @ Florence St  
 Tampa, FL

File Name : 13015-3 US 41 @ Florence St  
 Site Code : 13015-3  
 Start Date : 1/10/2013  
 Page No : 2

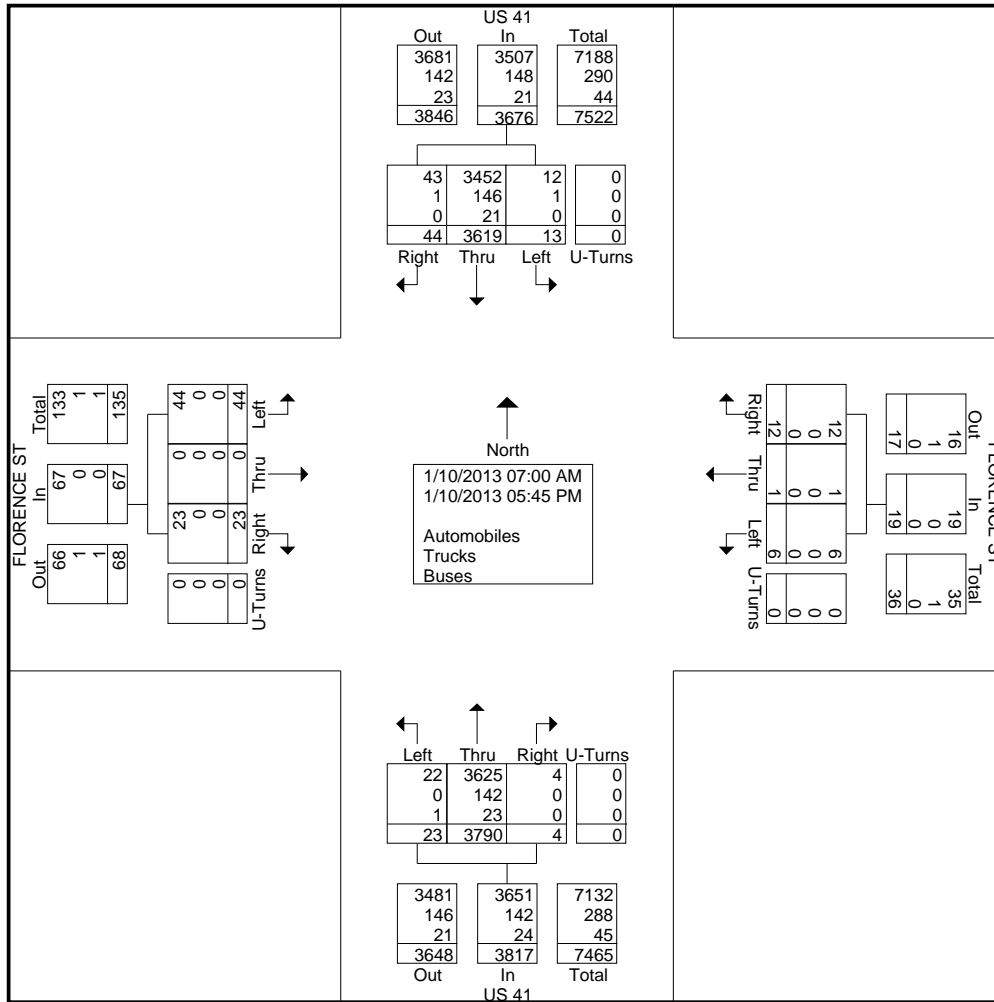



# Southern Traffic Services, Inc.

2911 Westfield Rd  
Gulf Breeze, FL 32563  
1-800-786-3374

*Traffic is our only business!*

US 41 @ Florence St  
Tampa, FL

File Name : 13015-3 US 41 @ Florence St  
Site Code : 13015-3  
Start Date : 1/10/2013  
Page No : 3

Start Time	US 41 Southbound				FLORENCE ST Westbound				US 41 Northbound				FLORENCE ST Eastbound				Int. Total				
	Thru	Right	U-Turns	App. Total	Left	Thru	Right	U-Turns	App. Total	Left	Thru	Right	U-Turns	App. Total	Left	Thru		Right	U-Turns	App. Total	
Peak Hour Analysis From 07:00 AM to 11:45 AM - Peak 1 of 1																					
Peak Hour for Entire Intersection Begins at 07:00 AM																					
07:00 AM	0	139	3	0	142	0	0	1	0	1	0	349	0	0	349	0	0	2	0	2	494
07:15 AM	2	157	1	0	160	0	0	0	0	0	1	385	0	0	386	1	0	0	0	1	547
07:30 AM	0	176	4	0	180	0	0	0	0	0	2	397	0	0	399	3	0	3	0	6	585
07:45 AM	0	155	3	0	158	1	0	1	0	2	2	324	0	0	326	4	0	0	0	4	490
Total Volume	2	627	11	0	640	1	0	2	0	3	5	1455	0	0	1460	8	0	5	0	13	2116
% App. Total	0.3	98	1.7	0		33.3	0	66.7	0		0.3	99.7	0	0		61.5	0	38.5	0		
PHF	.250	.891	.688	.000	.889	.250	.000	.500	.000	.375	.625	.916	.000	.000	.915	.500	.000	.417	.000	.542	.904
Automobiles	2	560	11	0	573	1	0	2	0	3	4	1424	0	0	1428	8	0	5	0	13	2017
% Automobiles	100	89.3	100	0	89.5	100	0	100	0	100	80.0	97.9	0	0	97.8	100	0	100	0	100	95.3
Trucks	0	60	0	0	60	0	0	0	0	0	0	25	0	0	25	0	0	0	0	0	85
% Trucks	0	9.6	0	0	9.4	0	0	0	0	0	0	1.7	0	0	1.7	0	0	0	0	0	4.0
Buses	0	7	0	0	7	0	0	0	0	0	1	6	0	0	7	0	0	0	0	0	14
% Buses	0	1.1	0	0	1.1	0	0	0	0	0	20.0	0.4	0	0	0.5	0	0	0	0	0	0.7

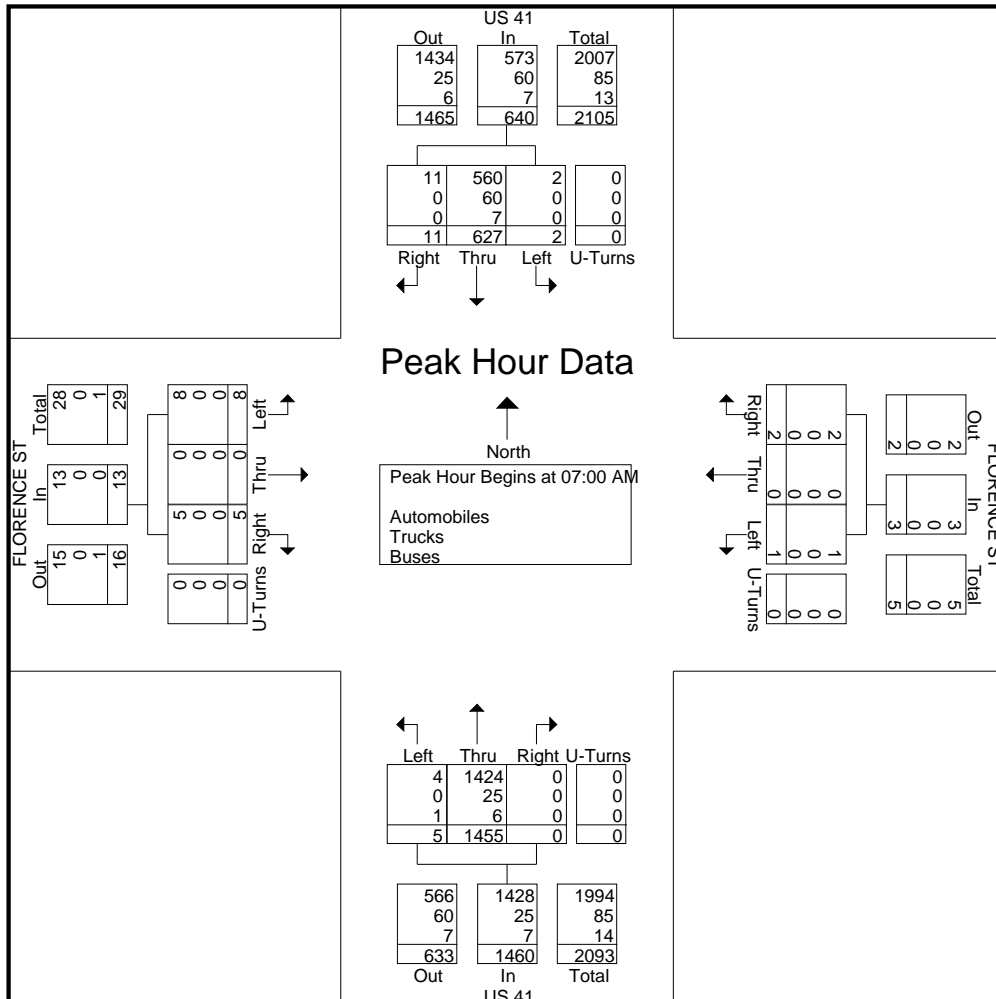



# Southern Traffic Services, Inc.

2911 Westfield Rd  
Gulf Breeze, FL 32563  
1-800-786-3374

*Traffic is our only business!*

US 41 @ Florence St  
Tampa, FL

File Name : 13015-3 US 41 @ Florence St  
Site Code : 13015-3  
Start Date : 1/10/2013  
Page No : 4

Start Time	US 41 Southbound					FLORENCE ST Westbound					US 41 Northbound					FLORENCE ST Eastbound					Int. Total
	Left	Thru	Right	U-Turns	App. Total	Left	Thru	Right	U-Turns	App. Total	Left	Thru	Right	U-Turns	App. Total	Left	Thru	Right	U-Turns	App. Total	

Peak Hour Analysis From 12:00 PM to 05:45 PM - Peak 1 of 1

Peak Hour for Entire Intersection Begins at 04:45 PM

04:45 PM	1	321	4	0	326	0	0	1	0	1	2	178	0	0	180	3	0	2	0	5	512
05:00 PM	2	319	5	0	326	1	0	1	0	2	4	188	0	0	192	4	0	1	0	5	525
05:15 PM	1	335	0	0	336	0	0	1	0	1	0	190	1	0	191	7	0	3	0	10	538
05:30 PM	0	374	3	0	377	0	0	0	0	0	2	178	0	0	180	1	0	0	0	1	558
Total Volume	4	1349	12	0	1365	1	0	3	0	4	8	734	1	0	743	15	0	6	0	21	2133
% App. Total	0.3	98.8	0.9	0		25	0	75	0		1.1	98.8	0.1	0		71.4	0	28.6	0		
PHF	.500	.902	.600	.000	.905	.250	.000	.750	.000	.500	.500	.966	.250	.000	.967	.536	.000	.500	.000	.525	.956
Automobiles	4	1330	12	0	1346	1	0	3	0	4	8	697	1	0	706	15	0	6	0	21	2077
% Automobiles	100	98.6	100	0	98.6	100	0	100	0	100	100	95.0	100	0	95.0	100	0	100	0	100	97.4
Trucks	0	14	0	0	14	0	0	0	0	0	0	34	0	0	34	0	0	0	0	0	48
% Trucks	0	1.0	0	0	1.0	0	0	0	0	0	0	4.6	0	0	4.6	0	0	0	0	0	2.3
Buses	0	5	0	0	5	0	0	0	0	0	0	3	0	0	3	0	0	0	0	0	8
% Buses	0	0.4	0	0	0.4	0	0	0	0	0	0	0.4	0	0	0.4	0	0	0	0	0	0.4

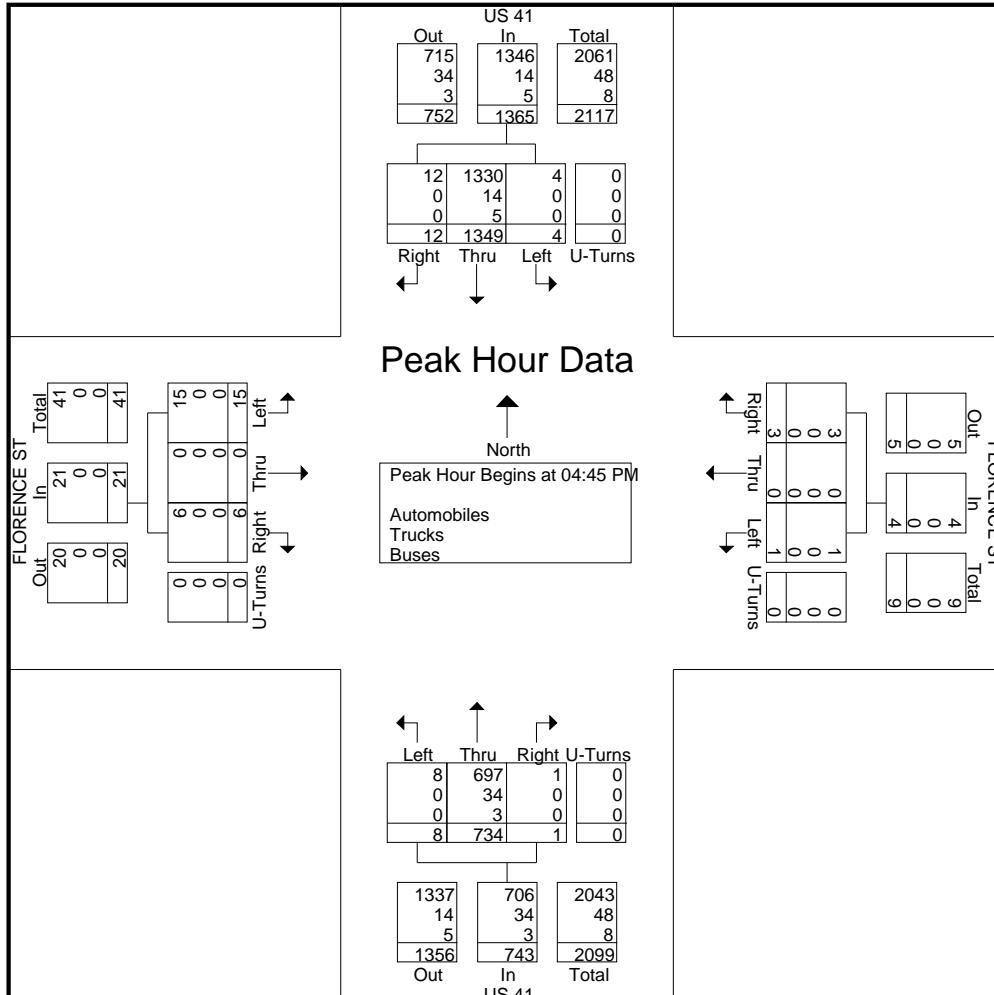



# Southern Traffic Services, Inc.

2911 Westfield Rd  
Gulf Breeze, FL 32563  
1-800-786-3374

*Traffic is our only business!*

US 41 @ Florence St  
Tampa, FL

File Name : 13015-3 US 41 @ Florence St  
Site Code : 13015-3  
Start Date : 1/10/2013  
Page No : 1

Groups Printed- Automobiles

Start Time	US 41 Southbound				FLORENCE ST Westbound				US 41 Northbound				FLORENCE ST Eastbound				Int. Total
	Left	Thru	Right	U-Turns	Left	Thru	Right	U-Turns	Left	Thru	Right	U-Turns	Left	Thru	Right	U-Turns	
07:00 AM	0	121	3	0	0	0	1	0	0	342	0	0	0	0	2	0	469
07:15 AM	2	135	1	0	0	0	0	0	1	374	0	0	1	0	0	0	514
07:30 AM	0	160	4	0	0	0	0	0	1	390	0	0	3	0	3	0	561
07:45 AM	0	144	3	0	1	0	1	0	2	318	0	0	4	0	0	0	473
Total	2	560	11	0	1	0	2	0	4	1424	0	0	8	0	5	0	2017
08:00 AM	0	76	2	0	0	0	0	0	1	294	0	0	1	0	0	0	374
08:15 AM	0	129	2	0	0	0	0	0	0	251	1	0	1	0	0	0	384
08:30 AM	1	97	1	0	1	0	2	0	3	193	0	0	2	0	2	0	302
08:45 AM	0	72	1	0	0	0	2	0	0	163	0	0	3	0	0	0	241
Total	1	374	6	0	1	0	4	0	4	901	1	0	7	0	2	0	1301
<b>**BREAK**</b>																	
04:00 PM	1	281	3	0	0	0	0	0	1	148	1	0	2	0	5	0	442
04:15 PM	2	295	5	0	2	0	1	0	2	155	0	0	1	0	1	0	464
04:30 PM	1	273	4	0	0	0	1	0	2	159	1	0	6	0	1	0	448
04:45 PM	1	315	4	0	0	0	1	0	2	162	0	0	3	0	2	0	490
Total	5	1164	16	0	2	0	3	0	7	624	2	0	12	0	9	0	1844
05:00 PM	2	311	5	0	1	0	1	0	4	180	0	0	4	0	1	0	509
05:15 PM	1	333	0	0	0	0	1	0	0	184	1	0	7	0	3	0	530
05:30 PM	0	371	3	0	0	0	0	0	2	171	0	0	1	0	0	0	548
05:45 PM	1	339	2	0	1	1	1	0	1	141	0	0	5	0	3	0	495
Total	4	1354	10	0	2	1	3	0	7	676	1	0	17	0	7	0	2082
Grand Total	12	3452	43	0	6	1	12	0	22	3625	4	0	44	0	23	0	7244
Apprch %	0.3	98.4	1.2	0	31.6	5.3	63.2	0	0.6	99.3	0.1	0	65.7	0	34.3	0	
Total %	0.2	47.7	0.6	0	0.1	0	0.2	0	0.3	50	0.1	0	0.6	0	0.3	0	



# Southern Traffic Services, Inc.

2911 Westfield Rd  
Gulf Breeze, FL 32563  
1-800-786-3374

*Traffic is our only business!*

US 41 @ Florence St  
Tampa, FL

File Name : 13015-3 US 41 @ Florence St  
Site Code : 13015-3  
Start Date : 1/10/2013  
Page No : 2

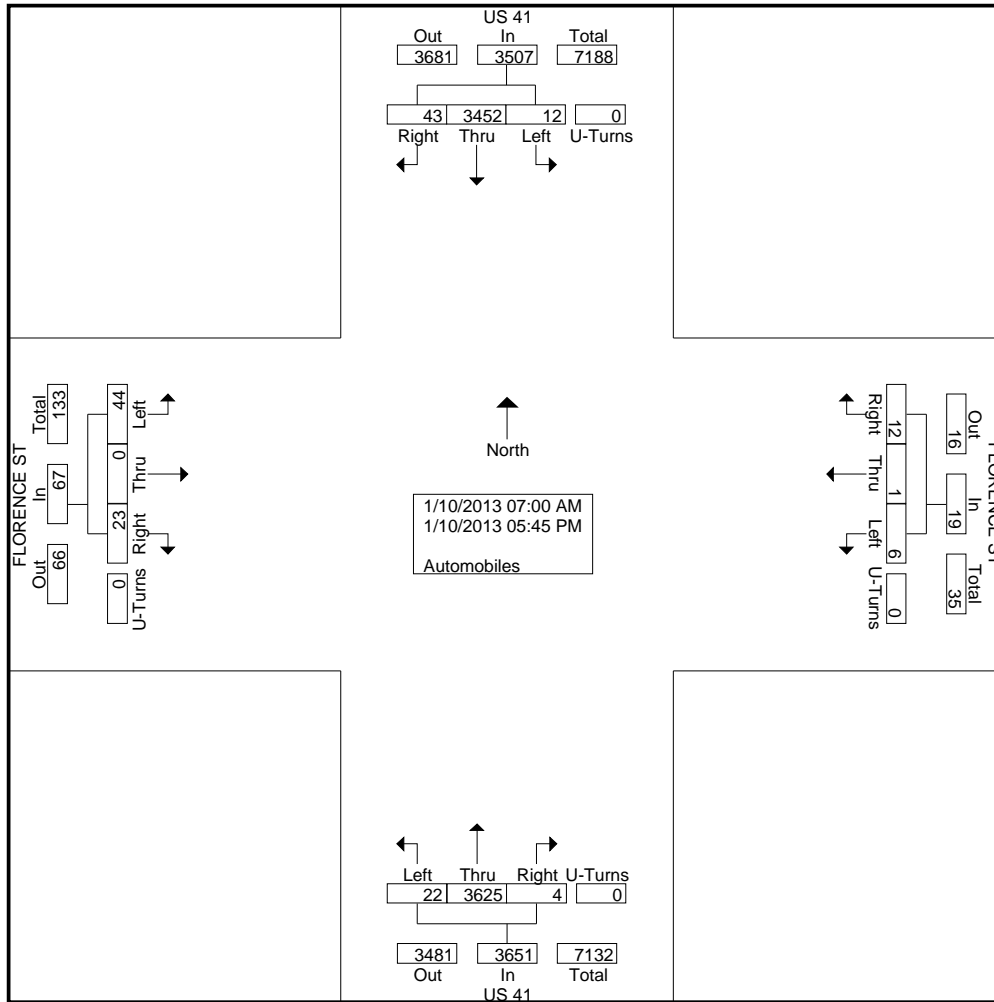



# Southern Traffic Services, Inc.

2911 Westfield Rd  
Gulf Breeze, FL 32563  
1-800-786-3374

*Traffic is our only business!*

US 41 @ Florence St  
Tampa, FL

File Name : 13015-3 US 41 @ Florence St  
Site Code : 13015-3  
Start Date : 1/10/2013  
Page No : 3

Start Time	US 41 Southbound				FLORENCE ST Westbound				US 41 Northbound				FLORENCE ST Eastbound				Int. Total				
	Thru	Right	U-Turns	App. Total	Left	Thru	Right	U-Turns	App. Total	Left	Thru	Right	U-Turns	App. Total	Left	Thru		Right	U-Turns	App. Total	
Peak Hour Analysis From 07:00 AM to 11:45 AM - Peak 1 of 1																					
Peak Hour for Entire Intersection Begins at 07:00 AM																					
07:00 AM	0	121	3	0	124	0	0	1	0	1	0	342	0	0	342	0	0	2	0	2	469
07:15 AM	2	135	1	0	138	0	0	0	0	0	1	374	0	0	375	1	0	0	0	1	514
07:30 AM	0	160	4	0	164	0	0	0	0	0	1	390	0	0	391	3	0	3	0	6	561
07:45 AM	0	144	3	0	147	1	0	1	0	2	2	318	0	0	320	4	0	0	0	4	473
Total Volume	2	560	11	0	573	1	0	2	0	3	4	1424	0	0	1428	8	0	5	0	13	2017
% App. Total	0.3	97.7	1.9	0		33.3	0	66.7	0		0.3	99.7	0	0		61.5	0	38.5	0		
PHF	.250	.875	.688	.000	.873	.250	.000	.500	.000	.375	.500	.913	.000	.000	.913	.500	.000	.417	.000	.542	.899

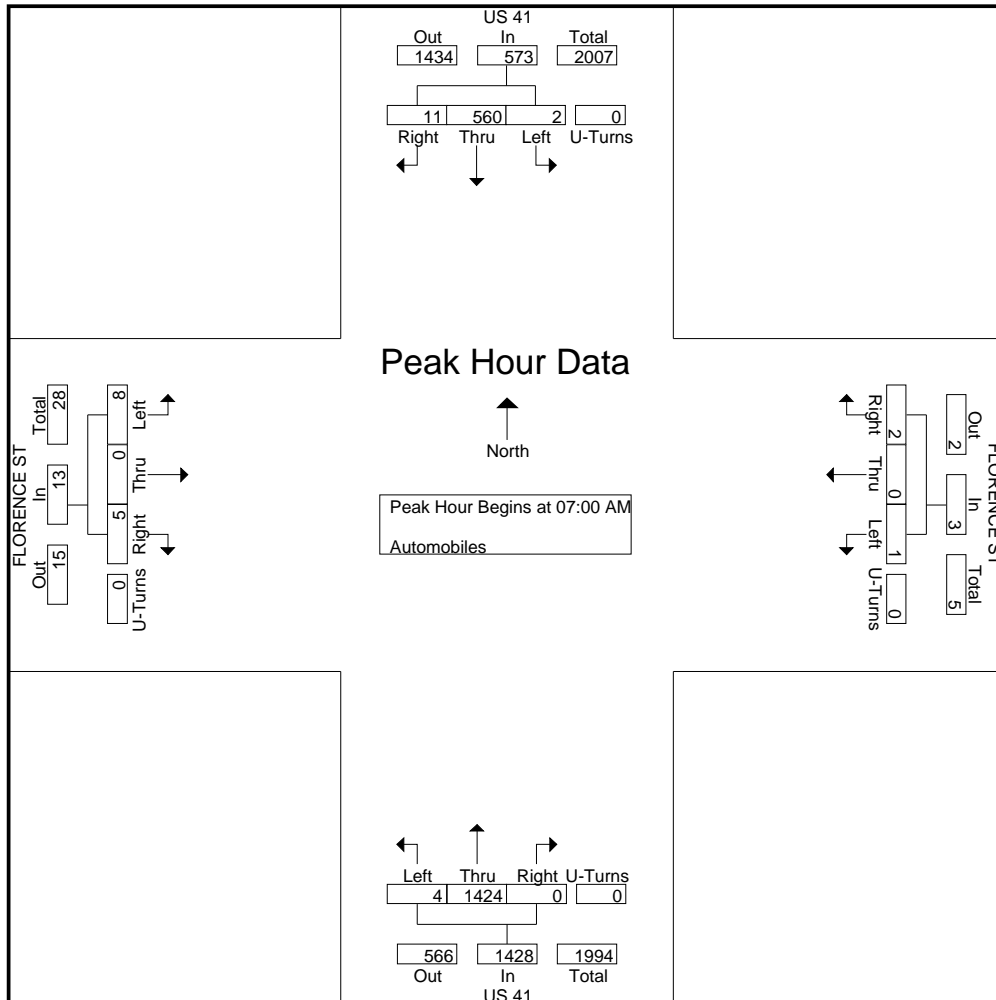



# Southern Traffic Services, Inc.

2911 Westfield Rd  
 Gulf Breeze, FL 32563  
 1-800-786-3374

*Traffic is our only business!*

US 41 @ Florence St  
 Tampa, FL

File Name : 13015-3 US 41 @ Florence St  
 Site Code : 13015-3  
 Start Date : 1/10/2013  
 Page No : 4

Start Time	US 41 Southbound					FLORENCE ST Westbound					US 41 Northbound					FLORENCE ST Eastbound					Int. Total
	Left	Thru	Right	U-Turns	App. Total	Left	Thru	Right	U-Turns	App. Total	Left	Thru	Right	U-Turns	App. Total	Left	Thru	Right	U-Turns	App. Total	
Peak Hour Analysis From 12:00 PM to 05:45 PM - Peak 1 of 1																					
Peak Hour for Entire Intersection Begins at 05:00 PM																					
05:00 PM	2	311	5	0	318	1	0	1	0	2	4	180	0	0	184	4	0	1	0	5	509
05:15 PM	1	333	0	0	334	0	0	1	0	1	0	184	1	0	185	7	0	3	0	10	530
05:30 PM	0	371	3	0	374	0	0	0	0	0	2	171	0	0	173	1	0	0	0	1	548
05:45 PM	1	339	2	0	342	1	1	1	0	3	1	141	0	0	142	5	0	3	0	8	495
Total Volume	4	1354	10	0	1368	2	1	3	0	6	7	676	1	0	684	17	0	7	0	24	2082
% App. Total	0.3	99	0.7	0		33.3	16.7	50	0		1	98.8	0.1	0		70.8	0	29.2	0		
PHF	.500	.912	.500	.000	.914	.500	.250	.750	.000	.500	.438	.918	.250	.000	.924	.607	.000	.583	.000	.600	.950

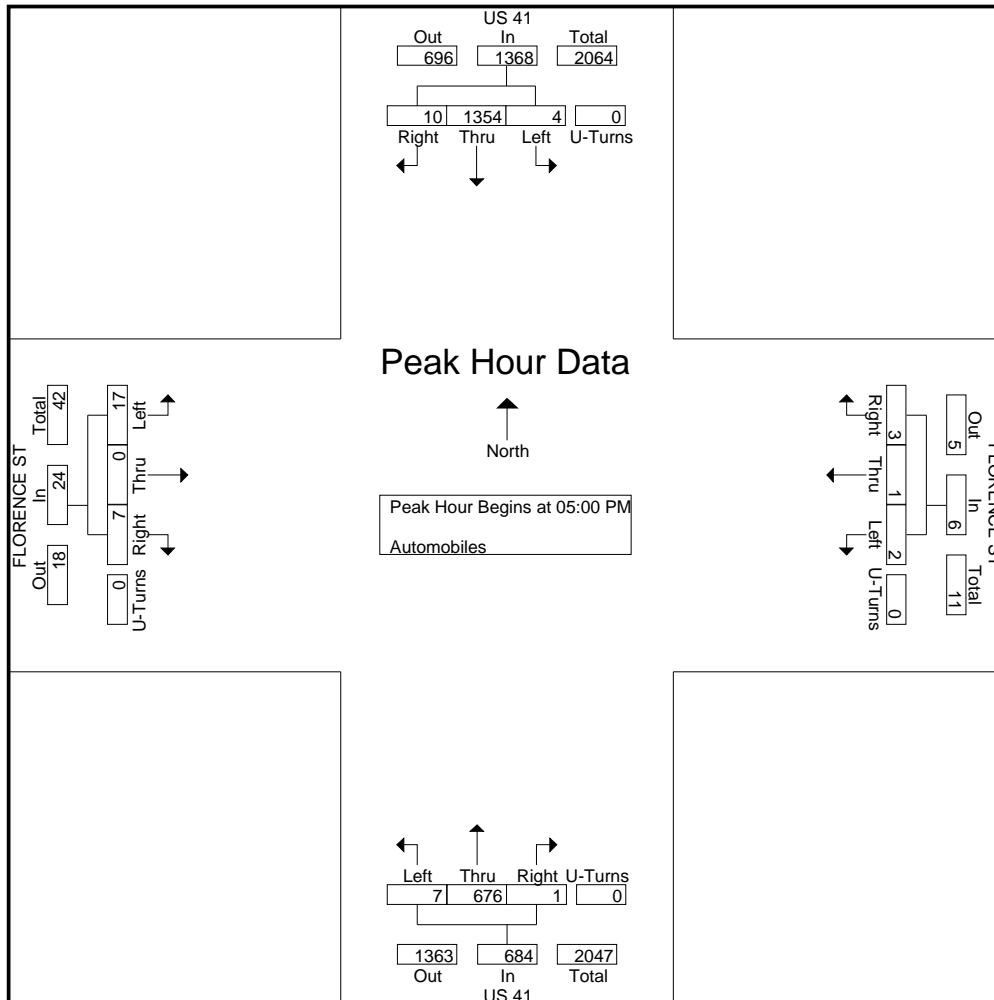







# Southern Traffic Services, Inc.

2911 Westfield Rd  
 Gulf Breeze, FL 32563  
 1-800-786-3374

*Traffic is our only business!*

US 41 @ Florence St  
 Tampa, FL

File Name : 13015-3 US 41 @ Florence St  
 Site Code : 13015-3  
 Start Date : 1/10/2013  
 Page No : 2

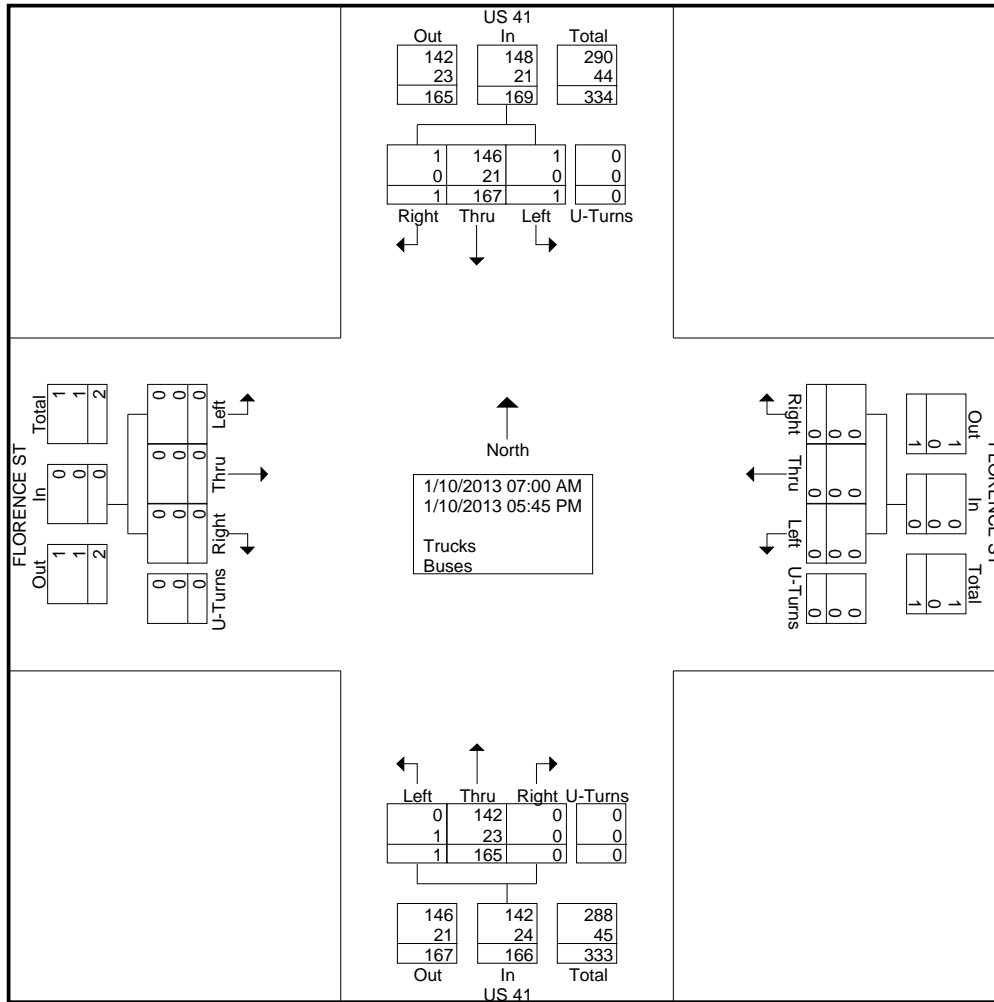



# Southern Traffic Services, Inc.

2911 Westfield Rd  
Gulf Breeze, FL 32563  
1-800-786-3374

*Traffic is our only business!*

US 41 @ Florence St  
Tampa, FL

File Name : 13015-3 US 41 @ Florence St  
Site Code : 13015-3  
Start Date : 1/10/2013  
Page No : 3

Start Time	US 41 Southbound				FLORENCE ST Westbound				US 41 Northbound				FLORENCE ST Eastbound				Int. Total				
	Thru	Right	U-Turns	App. Total	Left	Thru	Right	U-Turns	App. Total	Left	Thru	Right	U-Turns	App. Total	Left	Thru		Right	U-Turns	App. Total	
Peak Hour Analysis From 07:00 AM to 11:45 AM - Peak 1 of 1																					
Peak Hour for Entire Intersection Begins at 07:00 AM																					
07:00 AM	0	18	0	0	18	0	0	0	0	0	0	7	0	0	7	0	0	0	0	0	0
07:15 AM	0	22	0	0	22	0	0	0	0	0	0	11	0	0	11	0	0	0	0	0	0
07:30 AM	0	16	0	0	16	0	0	0	0	0	1	7	0	0	8	0	0	0	0	0	0
07:45 AM	0	11	0	0	11	0	0	0	0	0	0	6	0	0	6	0	0	0	0	0	0
Total Volume	0	67	0	0	67	0	0	0	0	0	1	31	0	0	32	0	0	0	0	0	0
% App. Total	0	100	0	0	100	0	0	0	0	0	3.1	96.9	0	0	100	0	0	0	0	0	0
PHF	.000	.761	.000	.000	.761	.000	.000	.000	.000	.000	.250	.705	.000	.000	.727	.000	.000	.000	.000	.000	.750
Trucks	0	60	0	0	60	0	0	0	0	0	0	25	0	0	25	0	0	0	0	0	0
% Trucks	0	89.6	0	0	89.6	0	0	0	0	0	0	80.6	0	0	78.1	0	0	0	0	0	0
Buses	0	7	0	0	7	0	0	0	0	0	1	6	0	0	7	0	0	0	0	0	0
% Buses	0	10.4	0	0	10.4	0	0	0	0	0	100	19.4	0	0	21.9	0	0	0	0	0	0

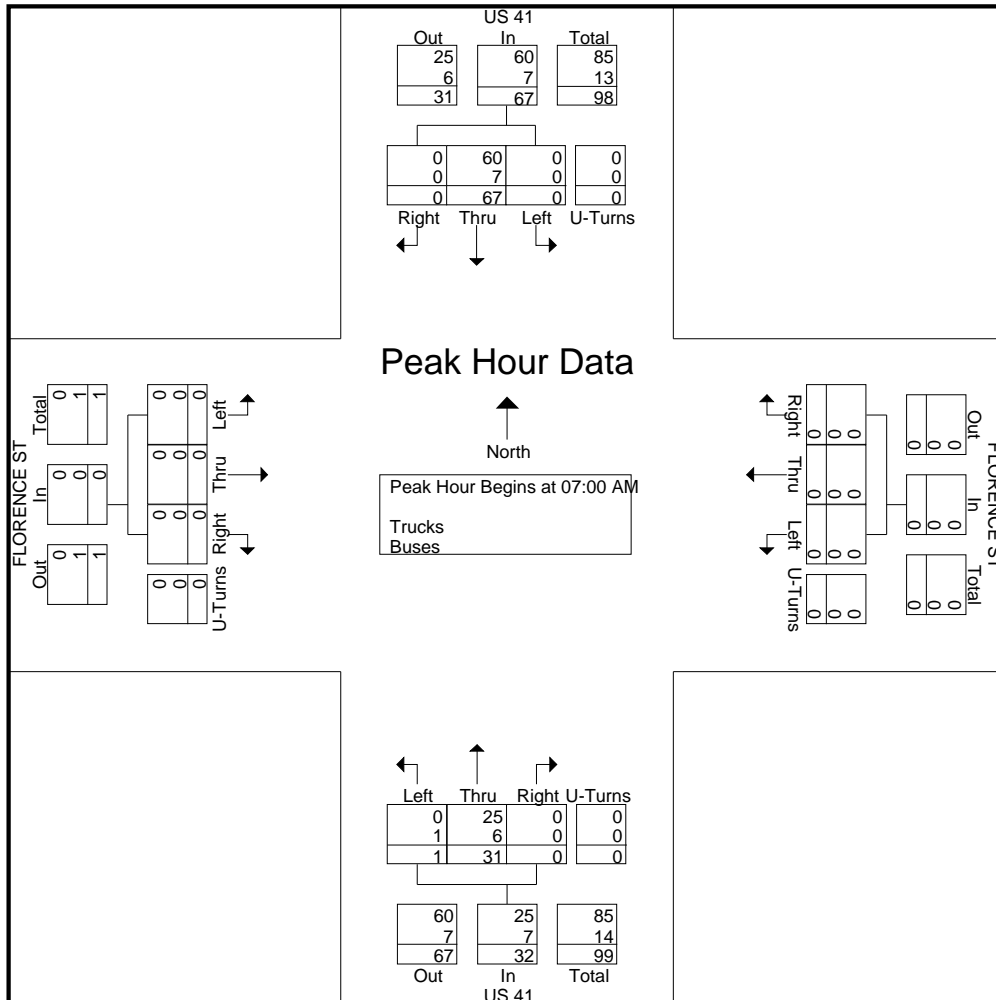



# Southern Traffic Services, Inc.

2911 Westfield Rd  
Gulf Breeze, FL 32563  
1-800-786-3374

*Traffic is our only business!*

US 41 @ Florence St  
Tampa, FL

File Name : 13015-3 US 41 @ Florence St  
Site Code : 13015-3  
Start Date : 1/10/2013  
Page No : 4

Start Time	US 41 Southbound					FLORENCE ST Westbound					US 41 Northbound					FLORENCE ST Eastbound					Int. Total
	Left	Thru	Right	U-Turns	App. Total	Left	Thru	Right	U-Turns	App. Total	Left	Thru	Right	U-Turns	App. Total	Left	Thru	Right	U-Turns	App. Total	

Peak Hour Analysis From 12:00 PM to 05:45 PM - Peak 1 of 1  
Peak Hour for Entire Intersection Begins at 04:00 PM

04:00 PM	0	8	0	0	8	0	0	0	0	0	0	21	0	0	21	0	0	0	0	0	29
04:15 PM	0	14	0	0	14	0	0	0	0	0	0	14	0	0	14	0	0	0	0	0	28
04:30 PM	0	5	0	0	5	0	0	0	0	0	0	14	0	0	14	0	0	0	0	0	19
04:45 PM	0	6	0	0	6	0	0	0	0	0	0	16	0	0	16	0	0	0	0	0	22
Total Volume	0	33	0	0	33	0	0	0	0	0	0	65	0	0	65	0	0	0	0	0	98
% App. Total	0	100	0	0		0	0	0	0		0	100	0	0		0	0	0	0		
PHF	.000	.589	.000	.000	.589	.000	.000	.000	.000	.000	.000	.774	.000	.000	.774	.000	.000	.000	.000	.000	.845
Trucks	0	27	0	0	27	0	0	0	0	0	0	58	0	0	58	0	0	0	0	0	85
% Trucks	0	81.8	0	0	81.8	0	0	0	0	0	0	89.2	0	0	89.2	0	0	0	0	0	86.7
Buses	0	6	0	0	6	0	0	0	0	0	0	7	0	0	7	0	0	0	0	0	13
% Buses	0	18.2	0	0	18.2	0	0	0	0	0	0	10.8	0	0	10.8	0	0	0	0	0	13.3

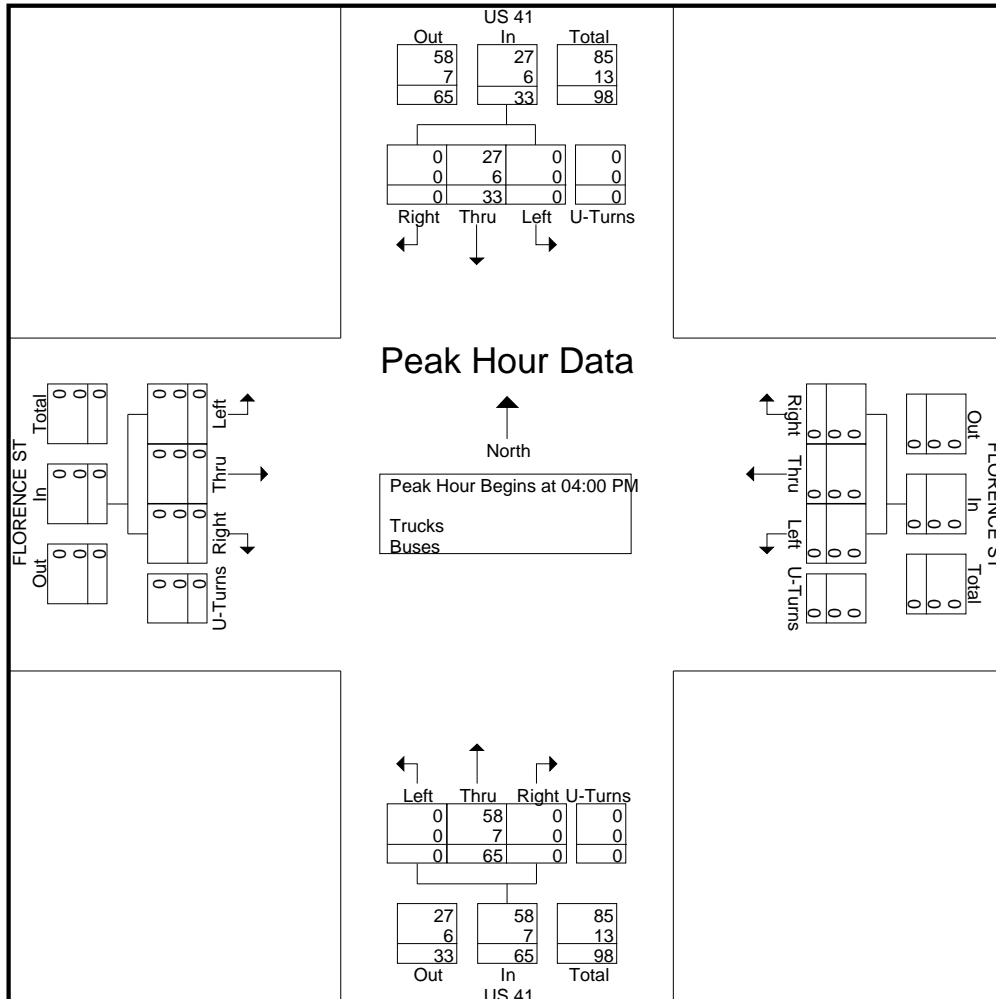



# Southern Traffic Services, Inc.

2911 Westfield Rd  
Gulf Breeze, FL 32563  
1-800-786-3374

*Traffic is our only business!*

US 41 @ Florence St  
Tampa, FL

File Name : 13015-3 US 41 @ Florence St Peds  
Site Code : 13015-3  
Start Date : 1/10/2013  
Page No : 1

Groups Printed- Peds

Start Time	US 41	FLORENCE ST	US 41	FLORENCE ST	Int. Total
	Southbound	Westbound	Northbound	Eastbound	
	Peds	Peds	Peds	Peds	
07:00 AM	0	0	1	4	5
07:15 AM	0	2	0	11	13
07:30 AM	2	0	0	5	7
07:45 AM	2	0	2	8	12
Total	4	2	3	28	37
08:00 AM	1	1	0	2	4
08:15 AM	0	2	1	4	7
08:30 AM	0	2	0	4	6
08:45 AM	0	2	0	1	3
Total	1	7	1	11	20
09:00 AM	0	0	0	0	0
09:15 AM	0	0	0	0	0
09:30 AM	0	0	0	0	0
09:45 AM	0	0	0	0	0
Total	0	0	0	0	0
10:00 AM	0	0	0	0	0
10:15 AM	0	0	0	0	0
10:30 AM	0	0	0	0	0
10:45 AM	0	0	0	0	0
Total	0	0	0	0	0
11:00 AM	0	0	0	0	0
11:15 AM	0	0	0	0	0
11:30 AM	0	0	0	0	0
11:45 AM	0	0	0	0	0
Total	0	0	0	0	0
12:00 PM	0	0	0	0	0
12:15 PM	0	0	0	0	0
12:30 PM	0	0	0	0	0
12:45 PM	0	0	0	0	0
Total	0	0	0	0	0
01:00 PM	0	0	0	0	0
01:15 PM	0	0	0	0	0
01:30 PM	0	0	0	0	0
01:45 PM	0	0	0	0	0
Total	0	0	0	0	0
02:00 PM	0	0	0	0	0
02:15 PM	0	0	0	0	0
02:30 PM	0	0	0	0	0
02:45 PM	0	0	0	0	0
Total	0	0	0	0	0
03:00 PM	0	0	0	0	0
03:15 PM	0	0	0	0	0
03:30 PM	0	0	0	0	0
03:45 PM	0	0	0	0	0
Total	0	0	0	0	0



# Southern Traffic Services, Inc.

2911 Westfield Rd  
 Gulf Breeze, FL 32563  
 1-800-786-3374

*Traffic is our only business!*

US 41 @ Florence St  
 Tampa, FL

File Name : 13015-3 US 41 @ Florence St Peds  
 Site Code : 13015-3  
 Start Date : 1/10/2013  
 Page No : 2

Groups Printed- Peds

Start Time	US 41 Southbound	FLORENCE ST Westbound	US 41 Northbound	FLORENCE ST Eastbound	Int. Total
	Peds	Peds	Peds	Peds	
04:00 PM	1	1	1	5	8
04:15 PM	0	1	2	4	7
04:30 PM	0	3	0	2	5
04:45 PM	0	2	1	0	3
Total	1	7	4	11	23
05:00 PM	0	0	0	3	3
05:15 PM	0	3	2	2	7
05:30 PM	0	2	0	0	2
05:45 PM	0	5	0	2	7
Total	0	10	2	7	19
Grand Total	6	26	10	57	99
Apprch %	100	100	100	100	
Total %	6.1	26.3	10.1	57.6	

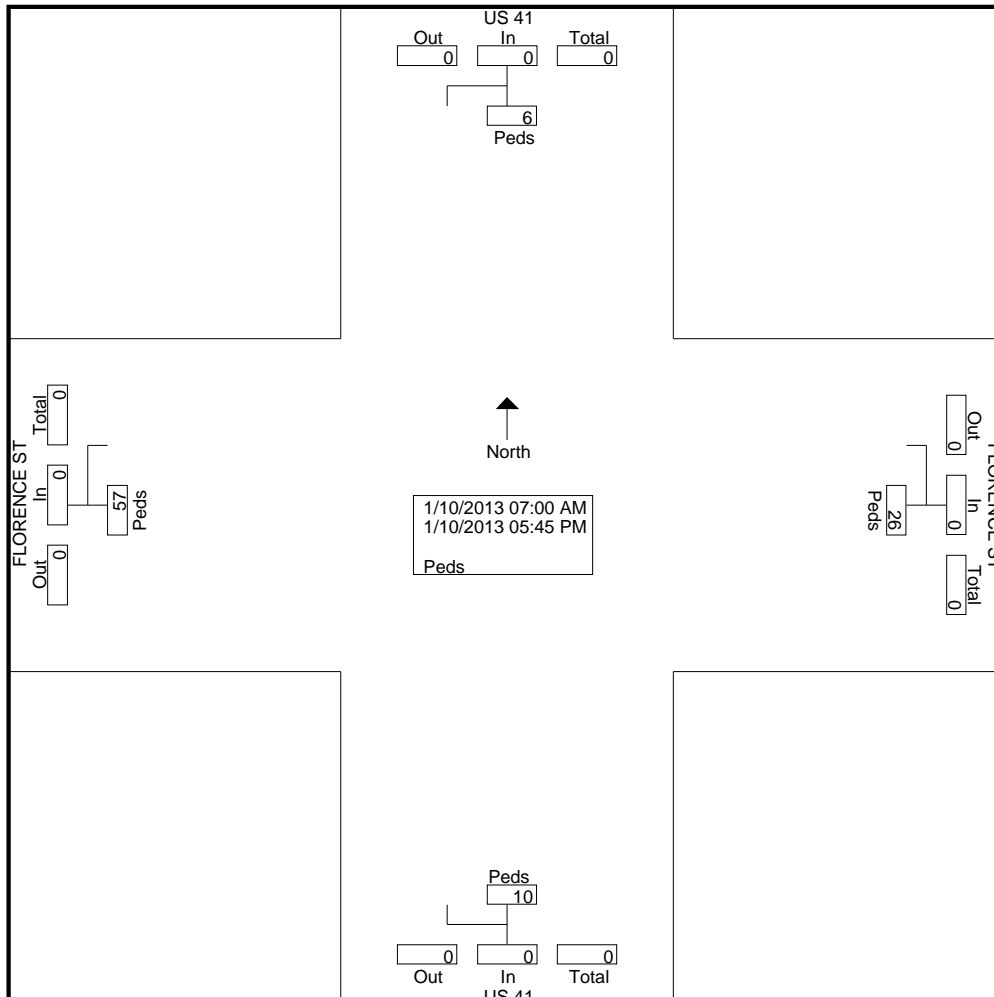

# Southern Traffic Services, Inc.

## Event Counts

**US 41 north of Florence Street**

**Northbound**

**Datasets:**

**Site:** [031] !XBZ  
**Input A:** 1 - North bound, A hit first. - Added to totals. (1)  
**Input B:** 0 - Unused or unknown. - Excluded from totals. (0)  
**Survey Duration:** 7:59 Monday, January 07, 2013 => 10:39 Friday, January 11, 2013  
**File:** G:\DATA\2013\Private\13015\marco\Jan -11-2013 DATA\UM031 NB.eco (Plus)  
**Identifier:** S543GTMK MC56-L5 [MC55] (c)Microcom 19Oct04  
**Algorithm:** Event Count  
**Data type:** Axle sensors - Paired (Class, Speed, Count)

**Profile:**

**Filter time:** 0:00 Tuesday, January 08, 2013 => 0:00 Friday, January 11, 2013  
**Name:** Factory default profile  
**Scheme:** Count events divided by two.  
**Units:** Non metric (ft, mi, ft/s, mph, lb, ton)  
**In profile:** Events = 38618

**Tuesday, January 08, 2013=12804, 15 minute drops**

0000	0100	0200	0300	0400	0500	0600	0700	0800	0900	1000	1100	1200	1300	1400	1500	1600	1700	1800	1900	2000	2100	2200	2300	
47	29	21	62	143	492	1209	1523	1008	722	646	678	684	730	831	892	794	814	522	311	231	193	129	93	
9	8	7	17	21	79	240	372	306	157	162	188	149	174	178	214	212	197	146	94	41	53	36	24	16
15	8	4	14	24	114	297	389	281	187	168	170	176	202	224	214	166	225	149	100	56	51	30	30	23
15	9	5	17	43	136	297	393	223	206	166	154	178	175	226	254	206	210	136	75	72	50	33	28	22
8	4	5	14	55	163	375	369	198	172	150	166	181	179	203	210	210	182	91	42	62	39	30	11	11

AM Peak 0645 - 0745 (1529), AM PHF=0.97 PM Peak 1500 - 1600 (892), PM PHF=0.88

**Wednesday, January 09, 2013=12935, 15 minute drops**

0000	0100	0200	0300	0400	0500	0600	0700	0800	0900	1000	1100	1200	1300	1400	1500	1600	1700	1800	1900	2000	2100	2200	2300	
72	31	40	60	134	541	1128	1512	1009	765	706	635	697	750	769	849	796	819	582	320	256	236	137	91	
16	7	13	19	16	88	206	348	318	210	160	157	150	236	199	210	208	220	179	117	64	88	48	34	14
23	11	9	16	36	106	303	373	275	165	188	155	184	156	188	164	184	224	143	77	81	58	28	17	15
22	8	10	14	36	155	309	411	219	205	186	159	182	183	198	270	204	209	125	68	53	45	33	20	4
11	5	8	11	46	192	310	380	197	185	172	164	181	175	184	205	200	166	135	58	58	45	28	20	7

AM Peak 0700 - 0800 (1512), AM PHF=0.92 PM Peak 1530 - 1630 (867), PM PHF=0.80

**Thursday, January 10, 2013=12879, 15 minute drops**

0000	0100	0200	0300	0400	0500	0600	0700	0800	0900	1000	1100	1200	1300	1400	1500	1600	1700	1800	1900	2000	2100	2200	2300	
40	43	28	52	135	494	1123	1542	1029	700	645	718	658	719	787	911	803	779	590	334	308	212	142	87	
14	9	7	13	22	78	209	366	316	182	151	169	154	177	183	178	192	196	178	84	62	51	38	23	15
15	10	8	16	32	98	254	351	275	171	194	195	172	174	194	219	181	214	148	100	101	65	37	20	18
4	15	7	11	34	144	361	477	231	192	37	176	164	192	231	285	207	201	138	62	69	50	37	32	10
7	9	6	12	47	174	299	348	207	155	263	178	168	176	179	229	223	168	126	88	76	46	30	12	17

AM Peak 0700 - 0800 (1542), AM PHF=0.81 PM Peak 1515 - 1615 (925), PM PHF=0.81

# Southern Traffic Services, Inc.

## Event Counts

**US 41 north of Florence Street**

**Southbound**

**Datasets:**

**Site:** [031] !c9119  
**Input A:** 3 - South bound, A hit first. - Added to totals. (1)  
**Input B:** 0 - Unused or unknown. - Excluded from totals. (0)  
**Survey Duration:** 7:59 Monday, January 07, 2013 => 11:32 Friday, January 11, 2013  
**File:** G:\DATA\2013\Private\13015\marco\Jan -11-2013 DATA\UM031 SB.eco (Plus)  
**Identifier:** AP794M95 MC56-L5 [MC55] (c)Microcom 19Oct04  
**Algorithm:** Event Count  
**Data type:** Axle sensors - Paired (Class, Speed, Count)

**Profile:**

**Filter time:** 0:00 Tuesday, January 08, 2013 => 0:00 Friday, January 11, 2013  
**Name:** Factory default profile  
**Scheme:** Count events divided by two.  
**Units:** Non metric (ft, mi, ft/s, mph, lb, ton)  
**In profile:** Events = 37913

**Tuesday, January 08, 2013=12606, 15 minute drops**

0000	0100	0200	0300	0400	0500	0600	0700	0800	0900	1000	1100	1200	1300	1400	1500	1600	1700	1800	1900	2000	2100	2200	2300	
127	49	41	60	105	209	550	693	564	565	538	634	599	642	694	1019	1276	1447	1068	562	445	320	250	149	
39	13	7	15	15	25	108	163	134	130	125	150	162	149	172	164	316	343	324	158	126	73	87	37	24
63	12	8	9	28	41	148	179	153	148	136	154	162	114	192	246	283	376	314	129	127	86	70	39	31
17	13	17	19	30	69	151	185	154	144	136	170	114	236	169	311	350	370	239	131	100	75	56	43	14
8	11	9	17	32	74	143	166	123	143	141	160	161	143	161	298	327	358	191	144	92	86	37	30	10

AM Peak 0700 - 0800 (693), AM PHF=0.94 PM Peak 1700 - 1800 (1447), PM PHF=0.96

**Wednesday, January 09, 2013=12702, 15 minute drops**

0000	0100	0200	0300	0400	0500	0600	0700	0800	0900	1000	1100	1200	1300	1400	1500	1600	1700	1800	1900	2000	2100	2200	2300	
79	60	53	39	72	252	561	706	610	540	578	563	655	638	729	998	1266	1453	1019	590	429	380	270	162	
24	13	14	6	11	20	123	170	135	137	151	139	169	173	159	194	312	335	333	166	116	103	85	46	25
31	21	15	15	18	42	126	162	165	146	146	150	146	139	190	241	288	429	276	112	110	103	64	35	24
14	18	16	11	15	83	171	201	162	113	139	154	178	163	180	276	351	341	222	183	106	95	67	51	23
10	8	8	7	28	107	141	173	148	144	142	120	162	163	200	287	315	348	188	129	97	79	54	30	25

AM Peak 0700 - 0800 (706), AM PHF=0.88 PM Peak 1700 - 1800 (1453), PM PHF=0.85

**Thursday, January 10, 2013=12605, 15 minute drops**

0000	0100	0200	0300	0400	0500	0600	0700	0800	0900	1000	1100	1200	1300	1400	1500	1600	1700	1800	1900	2000	2100	2200	2300	
97	68	52	43	85	222	563	719	507	554	510	578	619	644	784	992	1231	1460	1020	620	485	316	261	175	
25	15	9	9	11	32	115	154	99	153	110	145	154	156	163	213	294	339	282	199	154	85	65	16	31
24	13	14	9	18	43	158	193	162	122	121	135	166	165	215	235	313	391	271	170	112	94	71	75	37
23	22	20	12	27	57	152	191	150	143	130	149	146	109	186	253	278	386	247	139	108	66	64	39	26
25	18	9	13	29	90	138	181	96	136	149	149	153	214	220	291	346	344	220	112	111	71	61	45	20

AM Peak 0700 - 0800 (719), AM PHF=0.93 PM Peak 1645 - 1745 (1462), PM PHF=0.93

# Southern Traffic Services, Inc.

## Event Counts

**US 41 south of Florence Street**

**Northbound**

**Datasets:**

**Site:** [032] !9024  
**Site:** [032] !C7040  
**Input A:** 1 - North bound, A hit first. - Added to totals. (1)  
**Input B:** 0 - Unused or unknown. - Excluded from totals. (0)  
**Survey Duration:** 7:56 Monday, January 07, 2013 => 10:42 Friday, January 11, 2013  
**File:** G:\DATA\2013\Private\13015\marco\Jan -11-2013 DATA\UM032 NB Slow.eco (Plus)  
**Identifier:** U345XNKN MC56-L5 [MC55] (c)Microcom 19Oct04  
**Algorithm:** Event Count  
**Data type:** Axle sensors - Paired (Class, Speed, Count)

**Profile:**

**Filter time:** 0:00 Tuesday, January 08, 2013 => 0:00 Friday, January 11, 2013  
**Name:** Factory default profile  
**Scheme:** Count events divided by two.  
**Units:** Non metric (ft, mi, ft/s, mph, lb, ton)  
**In profile:** Events = 39199

**Tuesday, January 08, 2013=12973, 15 minute drops**

0000	0100	0200	0300	0400	0500	0600	0700	0800	0900	1000	1100	1200	1300	1400	1500	1600	1700	1800	1900	2000	2100	2200	2300	
45	29	21	56	144	495	1229	1582	1030	738	658	683	698	722	822	887	799	809	549	324	239	186	132	96	
10	8	7	17	19	77	239	390	312	157	160	183	149	177	178	213	200	197	146	99	45	51	36	26	19
13	9	4	14	23	119	303	396	281	196	170	178	178	197	219	208	170	224	165	104	56	47	35	33	25
14	8	5	15	44	136	300	415	231	202	172	156	186	173	222	259	211	207	140	79	72	49	32	30	21
8	4	5	10	58	163	387	381	206	183	156	166	185	175	203	207	218	181	98	42	66	39	29	7	12

AM Peak 0645 - 0745 (1588), AM PHF=0.96 PM Peak 1500 - 1600 (887), PM PHF=0.86

**Wednesday, January 09, 2013=13155, 15 minute drops**

0000	0100	0200	0300	0400	0500	0600	0700	0800	0900	1000	1100	1200	1300	1400	1500	1600	1700	1800	1900	2000	2100	2200	2300	
77	33	41	62	142	566	1187	1621	1032	778	696	635	688	722	757	869	789	823	595	325	255	235	136	91	
19	7	14	18	18	93	221	371	323	214	167	157	155	218	191	212	202	230	180	114	62	85	43	33	17
25	13	9	18	37	108	309	409	274	173	186	158	179	155	191	168	183	218	150	80	81	56	32	18	15
21	8	10	13	36	164	326	436	232	203	172	156	174	179	200	276	205	210	124	71	53	49	31	22	4
12	5	8	13	51	201	331	405	203	188	171	164	180	170	175	213	199	165	141	60	59	45	30	18	8

AM Peak 0700 - 0800 (1621), AM PHF=0.93 PM Peak 1530 - 1630 (874), PM PHF=0.79

**Thursday, January 10, 2013=13071, 15 minute drops**

0000	0100	0200	0300	0400	0500	0600	0700	0800	0900	1000	1100	1200	1300	1400	1500	1600	1700	1800	1900	2000	2100	2200	2300	
44	46	28	51	136	527	1198	1616	1049	715	654	706	660	701	762	907	792	757	609	353	320	208	144	88	
17	10	7	12	22	83	221	381	329	193	162	164	152	169	184	181	200	196	185	90	64	52	38	22	15
15	11	8	16	31	107	272	378	289	171	186	193	170	175	191	219	191	204	147	106	104	61	40	21	18
4	16	7	11	35	156	378	497	232	199	38	173	171	185	216	282	200	195	140	69	71	49	35	30	13
8	9	6	12	48	181	327	360	199	152	268	176	167	172	171	225	201	162	137	88	81	46	31	15	15

AM Peak 0700 - 0800 (1616), AM PHF=0.81 PM Peak 1515 - 1615 (926), PM PHF=0.82



# Southern Traffic Services, Inc.

## Event Counts

**US 41 south of Florence Street**

**Southbound**

**Datasets:**

**Site:** [032] !CC  
**Site:** [032] !C6543  
**Input A:** 3 - South bound, A hit first. - Added to totals. (1)  
**Input B:** 0 - Unused or unknown. - Excluded from totals. (0)  
**Survey Duration:** 7:57 Monday, January 07, 2013 => 10:56 Friday, January 11, 2013  
**File:** G:\DATA\2013\Private\13015\marco\Jan -11-2013 DATA\UM032 SB Slow.eco (Plus)  
**Identifier:** T583MW10 MC56-L5 [MC55] (c)Microcom 19Oct04  
**Algorithm:** Event Count  
**Data type:** Axle sensors - Paired (Class, Speed, Count)

**Profile:**

**Filter time:** 0:00 Tuesday, January 08, 2013 => 0:00 Friday, January 11, 2013  
**Name:** Factory default profile  
**Scheme:** Count events divided by two.  
**Units:** Non metric (ft, mi, ft/s, mph, lb, ton)  
**In profile:** Events = 39325

**Tuesday, January 08, 2013=13070, 15 minute drops**

0000	0100	0200	0300	0400	0500	0600	0700	0800	0900	1000	1100	1200	1300	1400	1500	1600	1700	1800	1900	2000	2100	2200	2300	
128	52	41	59	103	218	581	716	592	589	541	651	638	662	695	1039	1327	1507	1137	589	470	323	263	149	
39	13	7	12	13	23	107	171	144	137	125	151	180	150	173	171	320	356	348	170	133	79	90	35	24
63	13	7	12	29	44	159	184	158	158	141	163	168	118	189	254	302	392	342	133	134	82	74	40	33
18	14	17	20	29	73	150	192	165	146	130	179	118	236	180	303	358	382	238	138	110	74	60	43	15
8	12	10	15	32	78	165	169	125	148	145	158	172	158	153	311	347	377	209	148	93	88	39	31	10

AM Peak 0700 - 0800 (716), AM PHF=0.93 PM Peak 1700 - 1800 (1507), PM PHF=0.96

**Wednesday, January 09, 2013=13164, 15 minute drops**

0000	0100	0200	0300	0400	0500	0600	0700	0800	0900	1000	1100	1200	1300	1400	1500	1600	1700	1800	1900	2000	2100	2200	2300	
82	57	54	40	75	267	599	751	645	572	614	562	667	662	752	1033	1298	1498	1060	600	443	387	278	168	
24	13	14	6	12	20	127	177	142	140	163	137	168	177	167	204	317	341	347	168	121	104	89	51	28
33	18	15	15	19	44	139	168	172	156	151	153	148	146	200	244	305	436	280	110	120	101	63	33	25
15	18	17	11	16	89	185	207	173	119	141	154	184	167	185	288	346	361	231	197	104	105	67	53	24
10	8	8	8	28	114	148	199	158	157	159	118	167	172	200	297	330	360	202	125	98	77	59	31	25

AM Peak 0700 - 0800 (751), AM PHF=0.91 PM Peak 1715 - 1815 (1504), PM PHF=0.86

**Thursday, January 10, 2013=13091, 15 minute drops**

0000	0100	0200	0300	0400	0500	0600	0700	0800	0900	1000	1100	1200	1300	1400	1500	1600	1700	1800	1900	2000	2100	2200	2300	
102	73	51	41	87	239	598	766	521	585	532	601	651	645	806	1014	1267	1510	1063	648	515	332	271	173	
28	16	9	8	12	32	123	165	107	164	115	145	164	159	165	228	305	350	296	207	158	93	65	15	32
25	13	14	9	19	43	169	197	166	134	125	142	167	168	216	233	320	402	283	174	116	97	76	77	39
24	25	19	13	22	65	161	208	153	152	136	156	156	109	194	249	287	391	261	152	113	66	66	38	26
25	19	9	11	34	99	145	196	95	135	156	158	164	209	231	304	355	367	223	115	128	76	64	43	20

AM Peak 0700 - 0800 (766), AM PHF=0.92 PM Peak 1700 - 1800 (1510), PM PHF=0.94

# Southern Traffic Services, Inc.

## Event Counts

**Florence Street east of US 41**

**Eastbound**

**Datasets:**

**Site:** [033] !4160  
**Input A:** 2 - East bound, A hit first. - Added to totals. (1)  
**Input B:** 0 - Unused or unknown. - Excluded from totals. (0)  
**Survey Duration:** 7:58 Monday, January 07, 2013 => 11:00 Friday, January 11, 2013  
**File:** G:\DATA\2013\Private\13015\marco\Jan -11-2013 DATA\UM033 EB.eco (Plus)  
**Identifier:** P580AX0J MC56-L5 [MC55] (c)Microcom 19Oct04  
**Algorithm:** Event Count  
**Data type:** Axle sensors - Paired (Class, Speed, Count)

**Profile:**

**Filter time:** 0:00 Tuesday, January 08, 2013 => 0:00 Friday, January 11, 2013  
**Name:** Factory default profile  
**Scheme:** Count events divided by two.  
**Units:** Non metric (ft, mi, ft/s, mph, lb, ton)  
**In profile:** Events = 405

**Tuesday, January 08, 2013=120, 15 minute drops**

0000	0100	0200	0300	0400	0500	0600	0700	0800	0900	1000	1100	1200	1300	1400	1500	1600	1700	1800	1900	2000	2100	2200	2300	
0	0	0	1	2	0	1	8	2	7	4	7	4	4	16	9	12	11	12	4	6	2	4	4	
0	0	0	0	0	0	1	0	0	1	0	1	0	1	0	3	3	5	3	3	3	0	1	0	0
0	0	0	1	0	0	0	4	0	2	0	3	2	0	11	1	0	2	0	1	1	2	2	1	0
0	0	0	0	2	0	0	2	2	1	2	2	0	2	2	3	6	2	4	0	2	0	0	1	1
0	0	0	0	0	0	2	0	3	2	1	2	1	3	2	3	2	5	0	0	0	1	2	0	0

AM Peak 0700 - 0800 (8), AM PHF=0.50 PM Peak 1415 - 1515 (19), PM PHF=0.43

**Wednesday, January 09, 2013=152, 15 minute drops**

0000	0100	0200	0300	0400	0500	0600	0700	0800	0900	1000	1100	1200	1300	1400	1500	1600	1700	1800	1900	2000	2100	2200	2300	
1	1	2	3	0	3	3	8	5	3	10	13	20	6	13	11	7	14	12	5	3	5	2	2	
0	0	0	0	0	0	1	0	2	0	1	3	8	2	0	1	0	3	2	3	0	2	0	0	0
0	1	2	2	0	1	0	6	2	1	1	1	8	1	9	3	3	3	1	1	1	0	0	1	0
1	0	0	1	0	0	0	0	1	0	2	5	2	1	3	4	2	4	8	1	2	0	2	0	0
0	0	0	0	0	2	2	2	0	2	6	4	2	2	1	3	2	4	1	0	0	3	0	1	0

AM Peak 1130 - 1230 (25), AM PHF=0.78 PM Peak 1200 - 1300 (20), PM PHF=0.63

**Thursday, January 10, 2013=133, 15 minute drops**

0000	0100	0200	0300	0400	0500	0600	0700	0800	0900	1000	1100	1200	1300	1400	1500	1600	1700	1800	1900	2000	2100	2200	2300	
0	2	0	0	1	1	3	3	3	2	6	9	4	14	16	13	8	5	17	13	6	2	4	1	
0	1	0	0	0	0	0	0	1	1	2	3	1	5	0	3	3	2	3	5	1	0	2	0	0
0	0	0	0	0	0	0	2	1	0	0	4	1	1	8	2	2	2	5	3	2	2	2	1	2
0	0	0	0	1	1	2	0	1	1	1	1	2	1	7	8	1	0	5	2	0	0	0	0	1
0	1	0	0	0	0	1	1	0	0	3	1	0	7	1	0	2	1	4	3	3	0	0	0	0

AM Peak 1030 - 1130 (11), AM PHF=0.69 PM Peak 1345 - 1445 (22), PM PHF=0.69

# Southern Traffic Services, Inc.

## Event Counts

**Florence Street east of US 41**

**Westbound**

**Datasets:**

**Site:** [033] I3S  
**Input A:** 4 - West bound, A hit first. - Added to totals. (1)  
**Input B:** 0 - Unused or unknown. - Excluded from totals. (0)  
**Survey Duration:** 7:58 Monday, January 07, 2013 => 11:00 Friday, January 11, 2013  
**File:** G:\DATA\2013\Private\13015\marco\Jan -11-2013 DATA\UM033 WB.eco (Plus)  
**Identifier:** M251TZN1 MC56-6 [MC55] (c)Microcom 02/03/01  
**Algorithm:** Event Count  
**Data type:** Axle sensors - Paired (Class, Speed, Count)

**Profile:**

**Filter time:** 0:00 Tuesday, January 08, 2013 => 0:00 Friday, January 11, 2013  
**Name:** Factory default profile  
**Scheme:** Count events divided by two.  
**Units:** Non metric (ft, mi, ft/s, mph, lb, ton)  
**In profile:** Events = 420

**Tuesday, January 08, 2013=142, 15 minute drops**

0000	0100	0200	0300	0400	0500	0600	0700	0800	0900	1000	1100	1200	1300	1400	1500	1600	1700	1800	1900	2000	2100	2200	2300	
1	0	0	1	1	2	7	6	3	10	3	13	9	7	14	9	9	8	11	4	13	2	5	4	0
0	0	0	0	0	0	2	0	0	5	1	3	1	1	0	1	2	3	3	3	1	0	2	0	0
1	0	0	1	1	0	2	3	1	0	1	4	5	0	7	2	0	1	2	0	3	2	1	0	0
0	0	0	0	0	0	3	2	1	2	0	2	0	4	5	2	4	3	3	1	9	0	1	1	1
0	0	0	0	0	2	0	1	1	3	1	4	3	2	2	4	3	1	3	0	0	0	1	3	0

AM Peak 1100 - 1200 (13), AM PHF=0.81 PM Peak 1415 - 1515 (15), PM PHF=0.54

**Wednesday, January 09, 2013=133, 15 minute drops**

0000	0100	0200	0300	0400	0500	0600	0700	0800	0900	1000	1100	1200	1300	1400	1500	1600	1700	1800	1900	2000	2100	2200	2300	
1	0	1	2	1	6	5	4	5	10	6	7	11	11	11	10	5	11	12	4	6	2	1	1	1
0	0	0	0	0	0	1	0	2	2	0	1	2	4	1	2	2	3	3	1	3	1	0	0	1
0	0	1	0	1	2	1	2	2	1	0	1	3	2	5	3	1	0	1	1	1	0	0	0	0
1	0	0	1	0	1	1	0	1	6	2	1	4	3	4	3	0	5	4	2	1	0	0	0	0
0	0	0	1	0	3	2	2	0	1	4	4	2	2	1	2	2	3	4	0	1	1	1	1	0

AM Peak 1145 - 1245 (13), AM PHF=0.81 PM Peak 1215 - 1315 (13), PM PHF=0.81

**Thursday, January 10, 2013=145, 15 minute drops**

0000	0100	0200	0300	0400	0500	0600	0700	0800	0900	1000	1100	1200	1300	1400	1500	1600	1700	1800	1900	2000	2100	2200	2300	
1	2	1	2	1	4	5	3	6	6	4	16	8	12	11	9	6	5	8	7	19	4	4	1	1
1	2	0	0	0	0	1	1	0	1	2	6	4	4	0	2	1	1	3	4	0	0	0	0	0
0	0	1	0	1	0	2	0	0	2	0	7	3	2	4	3	3	2	1	1	4	3	3	0	3
0	0	0	1	0	2	2	0	3	1	0	2	1	1	3	3	1	0	3	1	3	0	0	1	1
0	0	0	1	0	2	0	2	3	2	2	1	0	5	4	1	1	2	1	1	12	1	1	0	0

AM Peak 1045 - 1145 (17), AM PHF=0.61 PM Peak 2000 - 2100 (19), PM PHF=0.40

# Southern Traffic Services, Inc.

## Event Counts

**Florence Street west of US 41**

**Eastbound**

**Datasets:**

**Site:** [034] !c7036  
**Input A:** 2 - East bound, A hit first. - Added to totals. (1)  
**Input B:** 0 - Unused or unknown. - Excluded from totals. (0)  
**Survey Duration:** 8:00 Monday, January 07, 2013 => 10:58 Friday, January 11, 2013  
**File:** G:\DATA\2013\Private\13015\marco\Jan -11-2013 DATA\UM034 EB.eco (Plus)  
**Identifier:** U406WXZ4 MC56-L5 [MC55] (c)Microcom 19Oct04  
**Algorithm:** Event Count  
**Data type:** Axle sensors - Paired (Class, Speed, Count)

**Profile:**

**Filter time:** 0:00 Tuesday, January 08, 2013 => 0:00 Friday, January 11, 2013  
**Name:** Factory default profile  
**Scheme:** Count events divided by two.  
**Units:** Non metric (ft, mi, ft/s, mph, lb, ton)  
**In profile:** Events = 607

**Tuesday, January 08, 2013=214, 15 minute drops**

0000	0100	0200	0300	0400	0500	0600	0700	0800	0900	1000	1100	1200	1300	1400	1500	1600	1700	1800	1900	2000	2100	2200	2300	
1	0	0	0	0	3	19	17	19	8	5	16	14	19	15	14	18	33	9	2	1	1	0	0	0
0	0	0	0	0	0	5	4	7	7	1	4	0	2	4	1	8	6	1	0	0	0	0	0	0
1	0	0	0	0	1	2	4	5	1	3	5	6	4	5	4	3	8	2	2	0	1	0	0	1
0	0	0	0	0	1	8	4	7	0	0	7	3	7	2	5	3	10	4	0	1	0	0	0	0
0	0	0	0	0	1	4	5	0	0	1	0	5	6	4	4	4	9	2	0	0	0	0	0	1

AM Peak 0745 - 0845 (24), AM PHF=0.86 PM Peak 1700 - 1800 (33), PM PHF=0.82

**Wednesday, January 09, 2013=186, 15 minute drops**

0000	0100	0200	0300	0400	0500	0600	0700	0800	0900	1000	1100	1200	1300	1400	1500	1600	1700	1800	1900	2000	2100	2200	2300	
2	0	0	0	0	3	14	16	16	7	5	12	22	6	19	9	18	23	6	2	2	2	2	0	0
0	0	0	0	0	0	1	5	5	3	1	0	5	2	3	2	5	7	3	0	0	0	1	0	0
1	0	0	0	0	1	5	4	5	1	1	2	6	2	3	2	6	5	2	1	1	1	1	1	0
0	0	0	0	0	1	5	3	6	0	1	3	2	1	9	4	3	5	1	0	0	1	0	0	0
1	0	0	0	0	1	3	4	0	3	2	7	9	1	4	1	4	6	0	1	1	0	0	0	0

AM Peak 1130 - 1230 (21), AM PHF=0.75 PM Peak 1700 - 1800 (23), PM PHF=0.82

**Thursday, January 10, 2013=207, 15 minute drops**

0000	0100	0200	0300	0400	0500	0600	0700	0800	0900	1000	1100	1200	1300	1400	1500	1600	1700	1800	1900	2000	2100	2200	2300	
0	0	0	0	0	2	17	14	10	9	4	16	21	14	16	16	27	23	5	3	2	8	0	0	0
0	0	0	0	0	1	5	2	2	3	2	2	2	6	4	2	6	8	1	1	1	1	0	0	0
0	0	0	0	0	0	3	2	1	3	2	4	4	1	3	3	3	6	2	1	0	5	0	0	0
0	0	0	0	0	0	7	6	4	2	0	3	10	2	4	3	11	2	2	1	0	1	0	0	0
0	0	0	0	0	1	2	4	3	1	0	7	5	5	5	8	7	7	0	0	1	1	0	0	0

AM Peak 1145 - 1245 (23), AM PHF=0.57 PM Peak 1630 - 1730 (32), PM PHF=0.73

# Southern Traffic Services, Inc.

## Event Counts

**Florence Street west of US 41**

**Westbound**

**Datasets:**

**Site:** [034] !C6564  
**Input A:** 4 - West bound, A hit first. - Added to totals. (1)  
**Input B:** 0 - Unused or unknown. - Excluded from totals. (0)  
**Survey Duration:** 7:59 Monday, January 07, 2013 => 10:57 Friday, January 11, 2013  
**File:** G:\DATA\2013\Private\13015\marco\Jan -11-2013 DATA\UM034 WB.eco (Plus)  
**Identifier:** T6352EDB MC56-L5 [MC55] (c)Microcom 19Oct04  
**Algorithm:** Event Count  
**Data type:** Axle sensors - Paired (Class, Speed, Count)

**Profile:**

**Filter time:** 0:00 Tuesday, January 08, 2013 => 0:00 Friday, January 11, 2013  
**Name:** Factory default profile  
**Scheme:** Count events divided by two.  
**Units:** Non metric (ft, mi, ft/s, mph, lb, ton)  
**In profile:** Events = 599

**Tuesday, January 08, 2013=207, 15 minute drops**

0000	0100	0200	0300	0400	0500	0600	0700	0800	0900	1000	1100	1200	1300	1400	1500	1600	1700	1800	1900	2000	2100	2200	2300
0	0	0	0	0	1	13	14	12	10	2	15	31	26	9	11	21	31	7	1	2	1	0	0
0	0	0	0	0	0	2	3	5	9	0	4	4	9	3	2	14	13	3	0	0	0	0	0
0	0	0	0	0	0	3	3	3	1	1	3	11	4	1	4	2	6	2	1	1	1	0	0
0	0	0	0	0	1	4	4	4	0	0	7	8	7	2	2	3	7	2	0	1	0	0	0
0	0	0	0	0	0	4	4	0	0	1	1	8	6	3	3	2	5	0	0	0	0	0	0

AM Peak 1145 - 1245 (24), AM PHF=0.55 PM Peak 1215 - 1315 (36), PM PHF=0.82

**Wednesday, January 09, 2013=186, 15 minute drops**

0000	0100	0200	0300	0400	0500	0600	0700	0800	0900	1000	1100	1200	1300	1400	1500	1600	1700	1800	1900	2000	2100	2200	2300
0	0	0	0	0	1	10	13	7	9	6	18	26	16	21	11	20	16	4	4	2	0	2	0
0	0	0	0	0	0	1	2	2	4	1	2	8	4	2	1	10	7	2	1	0	0	1	0
0	0	0	0	0	1	3	3	2	2	1	2	6	8	2	2	3	1	1	2	0	0	1	0
0	0	0	0	0	0	5	5	3	1	0	3	6	1	15	4	3	3	0	0	1	0	0	0
0	0	0	0	0	0	1	3	0	2	4	11	6	3	2	4	4	5	1	1	1	0	0	0

AM Peak 1145 - 1245 (31), AM PHF=0.70 PM Peak 1200 - 1300 (26), PM PHF=0.81

**Thursday, January 10, 2013=206, 15 minute drops**

0000	0100	0200	0300	0400	0500	0600	0700	0800	0900	1000	1100	1200	1300	1400	1500	1600	1700	1800	1900	2000	2100	2200	2300
0	0	0	0	0	0	10	19	12	10	4	20	17	16	14	22	28	22	4	0	2	6	0	0
0	0	0	0	0	0	2	2	3	2	1	5	3	5	2	2	5	10	0	0	0	2	0	0
0	0	0	0	0	0	3	1	2	2	1	3	1	6	4	2	7	1	1	0	1	4	0	0
0	0	0	0	0	0	3	8	4	3	1	6	8	1	4	5	9	6	2	0	0	0	0	0
0	0	0	0	0	0	2	8	3	3	1	6	5	4	4	13	7	5	1	0	1	0	0	0

AM Peak 1100 - 1200 (20), AM PHF=0.83 PM Peak 1545 - 1645 (34), PM PHF=0.65



# Southern Traffic Services, Inc.

2911 Westfield Rd  
Gulf Breeze, FL 32563  
1-800-786-3374

*Traffic is our only business!*

US 41 @ Symmes Rd  
Tampa, FL

File Name : 13015-4 us 41 @ symmes rd  
Site Code : 13015-4  
Start Date : 1/9/2013  
Page No : 1

Groups Printed- Automobiles - Trucks - Buses

Start Time	US 41 Southbound				SYMMES RD Westbound				US 41 Northbound				SERVICE RD Eastbound				Int. Total
	Left	Thru	Right	U-Turns	Left	Thru	Right	U-Turns	Left	Thru	Right	U-Turns	Left	Thru	Right	U-Turns	
07:00 AM	19	117	0	1	22	0	72	0	0	307	27	2	0	0	0	0	567
07:15 AM	18	118	0	0	31	0	99	0	0	277	43	2	0	0	0	0	588
07:30 AM	25	135	0	1	46	0	92	2	0	367	37	6	0	0	0	1	712
07:45 AM	19	127	0	2	37	0	60	0	0	318	30	1	0	0	0	0	594
<b>Total</b>	<b>81</b>	<b>497</b>	<b>0</b>	<b>4</b>	<b>136</b>	<b>0</b>	<b>323</b>	<b>2</b>	<b>0</b>	<b>1269</b>	<b>137</b>	<b>11</b>	<b>0</b>	<b>0</b>	<b>0</b>	<b>1</b>	<b>2461</b>
08:00 AM	17	101	0	2	21	0	66	1	0	272	25	0	0	0	0	0	505
08:15 AM	21	111	0	3	23	1	47	1	0	232	15	1	0	0	0	0	455
08:30 AM	16	127	0	3	14	1	53	0	0	194	13	1	0	0	0	0	422
08:45 AM	17	119	0	5	19	0	32	3	0	168	17	2	0	0	0	0	382
<b>Total</b>	<b>71</b>	<b>458</b>	<b>0</b>	<b>13</b>	<b>77</b>	<b>2</b>	<b>198</b>	<b>5</b>	<b>0</b>	<b>866</b>	<b>70</b>	<b>4</b>	<b>0</b>	<b>0</b>	<b>0</b>	<b>0</b>	<b>1764</b>
<b>**BREAK**</b>																	
04:00 PM	54	256	0	3	18	0	21	0	0	160	21	1	0	0	0	0	534
04:15 PM	61	272	0	2	17	0	30	0	0	136	31	2	0	0	0	0	551
04:30 PM	66	291	0	2	26	0	20	0	0	135	17	2	0	0	0	1	560
04:45 PM	65	285	0	4	13	0	23	0	0	171	23	1	0	0	0	0	585
<b>Total</b>	<b>246</b>	<b>1104</b>	<b>0</b>	<b>11</b>	<b>74</b>	<b>0</b>	<b>94</b>	<b>0</b>	<b>0</b>	<b>602</b>	<b>92</b>	<b>6</b>	<b>0</b>	<b>0</b>	<b>0</b>	<b>1</b>	<b>2230</b>
05:00 PM	70	259	0	4	19	0	19	2	0	158	20	0	0	1	0	0	552
05:15 PM	73	350	0	5	28	0	22	1	0	181	23	0	0	0	0	0	683
05:30 PM	91	317	3	2	16	0	26	0	0	170	16	2	0	0	0	0	643
05:45 PM	83	302	0	2	23	1	20	1	0	113	27	1	0	0	0	1	574
<b>Total</b>	<b>317</b>	<b>1228</b>	<b>3</b>	<b>13</b>	<b>86</b>	<b>1</b>	<b>87</b>	<b>4</b>	<b>0</b>	<b>622</b>	<b>86</b>	<b>3</b>	<b>0</b>	<b>1</b>	<b>0</b>	<b>1</b>	<b>2452</b>
<b>Grand Total</b>	<b>715</b>	<b>3287</b>	<b>3</b>	<b>41</b>	<b>373</b>	<b>3</b>	<b>702</b>	<b>11</b>	<b>0</b>	<b>3359</b>	<b>385</b>	<b>24</b>	<b>0</b>	<b>1</b>	<b>0</b>	<b>3</b>	<b>8907</b>
Apprch %	17.7	81.2	0.1	1	34.3	0.3	64.5	1	0	89.1	10.2	0.6	0	25	0	75	
Total %	8	36.9	0	0.5	4.2	0	7.9	0.1	0	37.7	4.3	0.3	0	0	0	0	
Automobiles	691	3096	3	13	354	3	675	11	0	3202	368	15	0	1	0	3	8435
% Automobiles	96.6	94.2	100	31.7	94.9	100	96.2	100	0	95.3	95.6	62.5	0	100	0	100	94.7
Trucks	20	176	0	28	10	0	25	0	0	144	7	9	0	0	0	0	419
% Trucks	2.8	5.4	0	68.3	2.7	0	3.6	0	0	4.3	1.8	37.5	0	0	0	0	4.7
Buses	4	15	0	0	9	0	2	0	0	13	10	0	0	0	0	0	53
% Buses	0.6	0.5	0	0	2.4	0	0.3	0	0	0.4	2.6	0	0	0	0	0	0.6



# Southern Traffic Services, Inc.

2911 Westfield Rd  
 Gulf Breeze, FL 32563  
 1-800-786-3374

*Traffic is our only business!*

US 41 @ Symmes Rd  
 Tampa, FL

File Name : 13015-4 us 41 @ symmes rd  
 Site Code : 13015-4  
 Start Date : 1/9/2013  
 Page No : 2

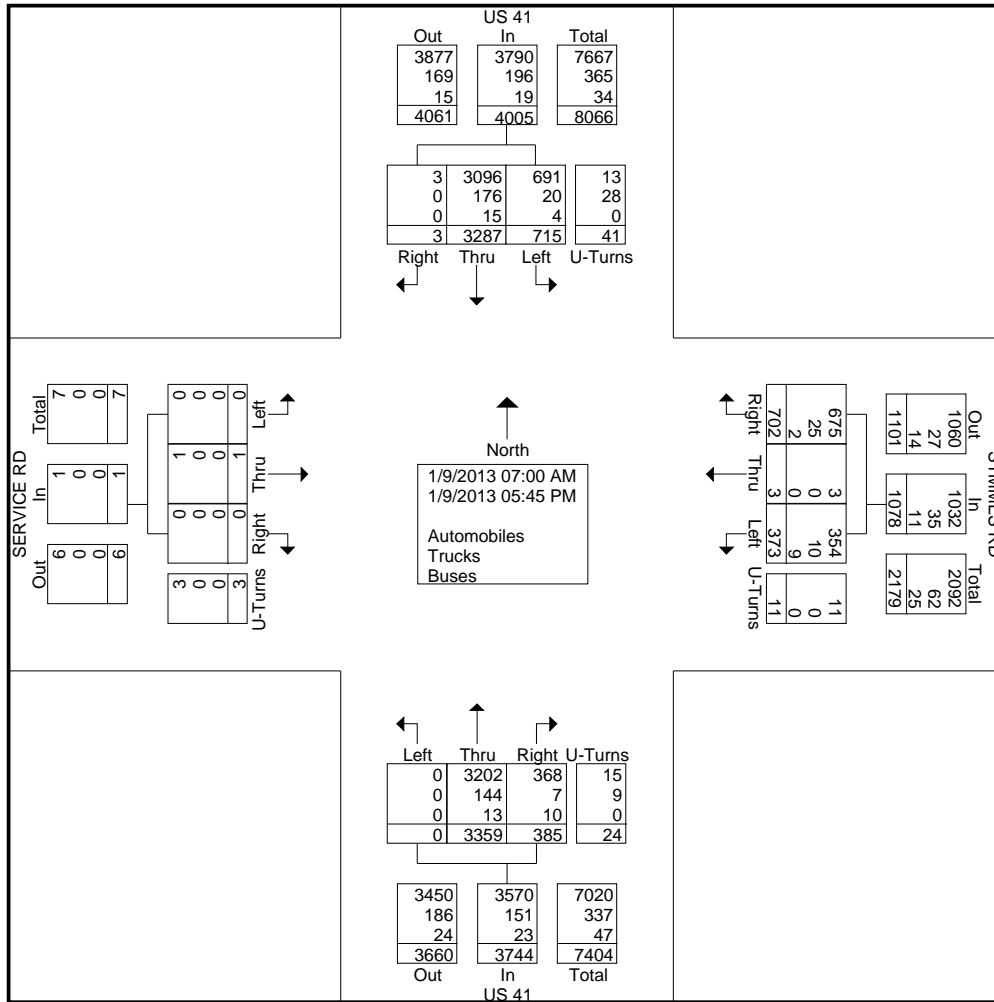



# Southern Traffic Services, Inc.

2911 Westfield Rd  
Gulf Breeze, FL 32563  
1-800-786-3374

*Traffic is our only business!*

US 41 @ Symmes Rd  
Tampa, FL

File Name : 13015-4 us 41 @ symmes rd  
Site Code : 13015-4  
Start Date : 1/9/2013  
Page No : 3

Start Time	US 41 Southbound				SYMMES RD Westbound				US 41 Northbound				SERVICE RD Eastbound				Int. Total				
	Thru	Right	U-Turns	App. Total	Left	Thru	Right	U-Turns	App. Total	Left	Thru	Right	U-Turns	App. Total	Left	Thru		Right	U-Turns	App. Total	
Peak Hour Analysis From 07:00 AM to 11:45 AM - Peak 1 of 1																					
Peak Hour for Entire Intersection Begins at 07:00 AM																					
07:00 AM	19	117	0	137	22	0	72	0	94	0	307	27	2	336	0	0	0	0	0	567	
07:15 AM	18	118	0	136	31	0	99	0	130	0	277	43	2	322	0	0	0	0	0	588	
07:30 AM	25	135	0	161	46	0	92	2	140	0	367	37	6	410	0	0	0	1	1	712	
07:45 AM	19	127	0	148	37	0	60	0	97	0	318	30	1	349	0	0	0	0	0	594	
Total Volume	81	497	0	582	136	0	323	2	461	0	1269	137	11	1417	0	0	0	1	1	2461	
% App. Total	13.9	85.4	0	0.7	29.5	0	70.1	0.4		0	89.6	9.7	0.8		0	0	0	100			
PHF	.810	.920	.000	.500	.904	.739	.000	.816	.250	.823	.000	.864	.797	.458	.864	.000	.000	.000	.250	.250	.864
Automobiles	73	436	0	510	125	0	308	2	435	0	1241	131	7	1379	0	0	0	1	1	2325	
% Automobiles	90.1	87.7	0	25.0	87.6	91.9	0	95.4	100	94.4	0	97.8	95.6	63.6	97.3	0	0	0	100	100	94.5
Trucks	6	60	0	3	69	5	0	14	0	19	0	25	0	4	29	0	0	0	0	0	117
% Trucks	7.4	12.1	0	75.0	11.9	3.7	0	4.3	0	4.1	0	2.0	0	36.4	2.0	0	0	0	0	0	4.8
Buses	2	1	0	3	6	0	0	1	0	7	0	3	6	0	9	0	0	0	0	0	19
% Buses	2.5	0.2	0	0.5	4.4	0	0	0.3	0	1.5	0	0.2	4.4	0	0.6	0	0	0	0	0	0.8

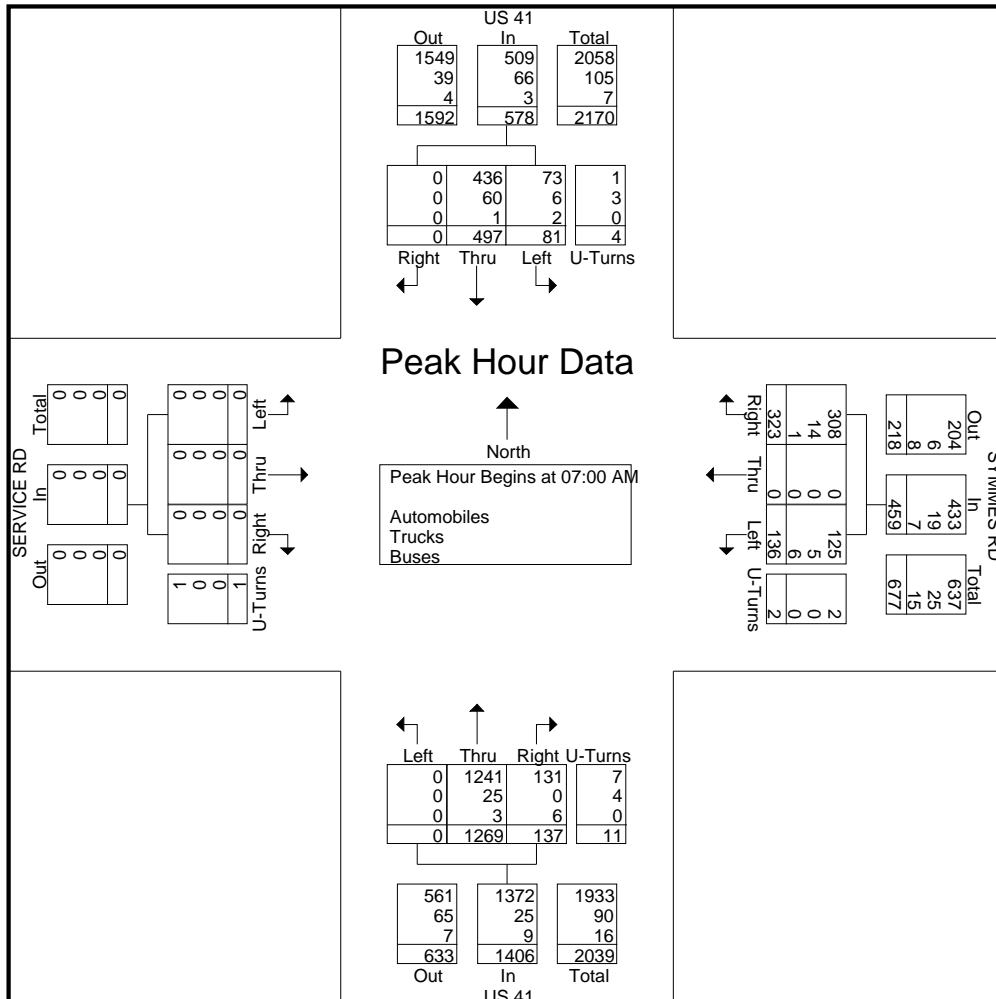





# Southern Traffic Services, Inc.

2911 Westfield Rd  
 Gulf Breeze, FL 32563  
 1-800-786-3374

*Traffic is our only business!*

US 41 @ Symmes Rd  
 Tampa, FL

File Name : 13015-4 us 41 @ symmes rd  
 Site Code : 13015-4  
 Start Date : 1/9/2013  
 Page No : 4

Start Time	US 41 Southbound					SYMMES RD Westbound					US 41 Northbound					SERVICE RD Eastbound					Int. Total
	Left	Thru	Right	U-Turns	App. Total	Left	Thru	Right	U-Turns	App. Total	Left	Thru	Right	U-Turns	App. Total	Left	Thru	Right	U-Turns	App. Total	

Peak Hour Analysis From 12:00 PM to 05:45 PM - Peak 1 of 1

Peak Hour for Entire Intersection Begins at 04:45 PM

04:45 PM	65	285	0	4	354	13	0	23	0	36	0	171	23	1	195	0	0	0	0	0	585
05:00 PM	70	259	0	4	333	19	0	19	2	40	0	158	20	0	178	0	1	0	0	1	552
05:15 PM	73	350	0	5	428	28	0	22	1	51	0	181	23	0	204	0	0	0	0	0	683
05:30 PM	91	317	3	2	413	16	0	26	0	42	0	170	16	2	188	0	0	0	0	0	643
Total Volume	299	1211	3	15	1528	76	0	90	3	169	0	680	82	3	765	0	1	0	0	1	2463
% App. Total	19.6	79.3	0.2	1		45	0	53.3	1.8		0	88.9	10.7	0.4		0	100	0	0		
PHF	.821	.865	.250	.750	.893	.679	.000	.865	.375	.828	.000	.939	.891	.375	.938	.000	.250	.000	.000	.250	.902
Automobiles	295	1185	3	2	1485	72	0	88	3	163	0	633	80	1	714	0	1	0	0	1	2363
% Automobiles	98.7	97.9	100	13.3	97.2	94.7	0	97.8	100	96.4	0	93.1	97.6	33.3	93.3	0	100	0	0	100	95.9
Trucks	3	22	0	13	38	1	0	2	0	3	0	42	2	2	46	0	0	0	0	0	87
% Trucks	1.0	1.8	0	86.7	2.5	1.3	0	2.2	0	1.8	0	6.2	2.4	66.7	6.0	0	0	0	0	0	3.5
Buses	1	4	0	0	5	3	0	0	0	3	0	5	0	0	5	0	0	0	0	0	13
% Buses	0.3	0.3	0	0	0.3	3.9	0	0	0	1.8	0	0.7	0	0	0.7	0	0	0	0	0	0.5

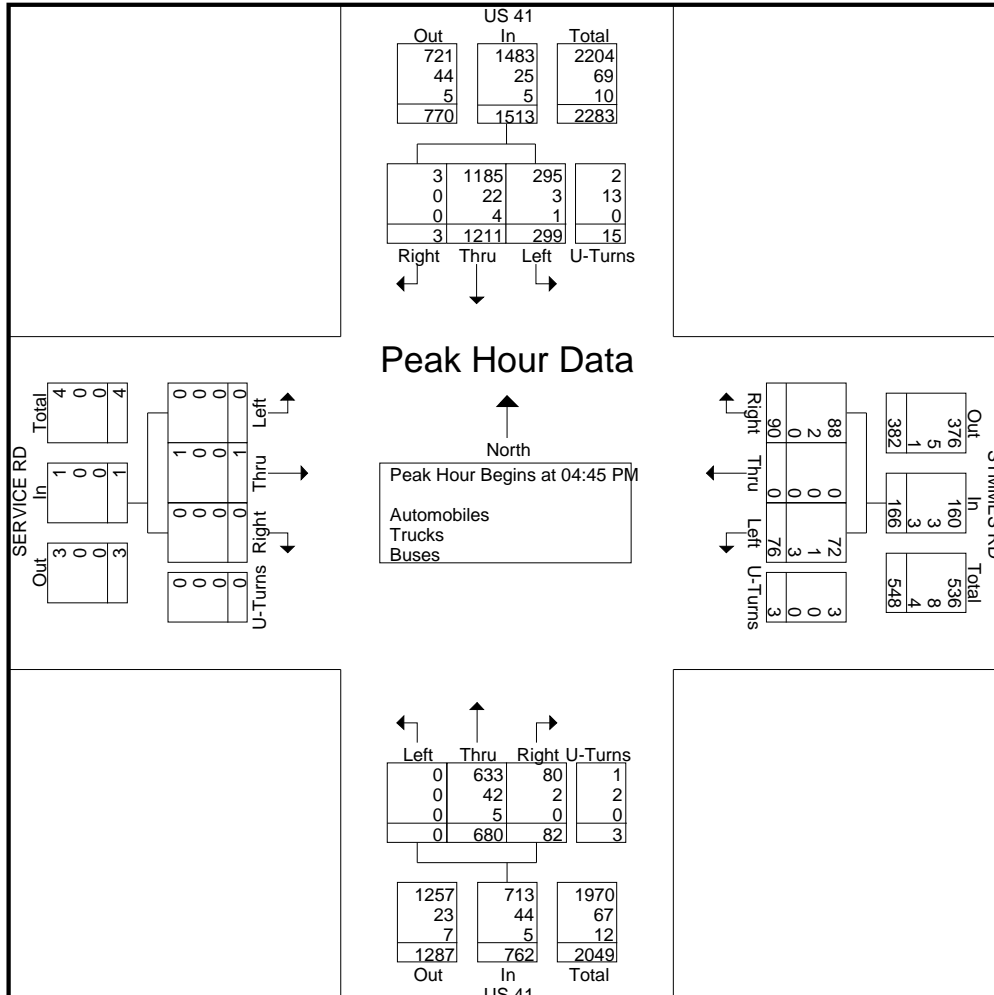



# Southern Traffic Services, Inc.

2911 Westfield Rd  
Gulf Breeze, FL 32563  
1-800-786-3374

*Traffic is our only business!*

US 41 @ Symmes Rd  
Tampa, FL

File Name : 13015-4 us 41 @ symmes rd  
Site Code : 13015-4  
Start Date : 1/9/2013  
Page No : 1

Groups Printed- Automobiles

Start Time	US 41 Southbound				SYMMES RD Westbound				US 41 Northbound				SERVICE RD Eastbound				Int. Total
	Left	Thru	Right	U-Turns	Left	Thru	Right	U-Turns	Left	Thru	Right	U-Turns	Left	Thru	Right	U-Turns	
07:00 AM	18	101	0	0	20	0	70	0	0	301	25	2	0	0	0	0	537
07:15 AM	18	106	0	0	28	0	93	0	0	270	40	2	0	0	0	0	557
07:30 AM	23	120	0	1	41	0	88	2	0	361	37	3	0	0	0	1	677
07:45 AM	14	109	0	0	36	0	57	0	0	309	29	0	0	0	0	0	554
<b>Total</b>	<b>73</b>	<b>436</b>	<b>0</b>	<b>1</b>	<b>125</b>	<b>0</b>	<b>308</b>	<b>2</b>	<b>0</b>	<b>1241</b>	<b>131</b>	<b>7</b>	<b>0</b>	<b>0</b>	<b>0</b>	<b>1</b>	<b>2325</b>
08:00 AM	16	86	0	2	21	0	65	1	0	255	23	0	0	0	0	0	469
08:15 AM	18	92	0	1	22	1	46	1	0	220	15	0	0	0	0	0	416
08:30 AM	16	111	0	3	13	1	52	0	0	188	13	1	0	0	0	0	398
08:45 AM	17	102	0	2	18	0	31	3	0	160	17	1	0	0	0	0	351
<b>Total</b>	<b>67</b>	<b>391</b>	<b>0</b>	<b>8</b>	<b>74</b>	<b>2</b>	<b>194</b>	<b>5</b>	<b>0</b>	<b>823</b>	<b>68</b>	<b>2</b>	<b>0</b>	<b>0</b>	<b>0</b>	<b>0</b>	<b>1634</b>
<b>**BREAK**</b>																	
04:00 PM	52	245	0	0	18	0	19	0	0	149	20	0	0	0	0	0	503
04:15 PM	58	260	0	0	16	0	29	0	0	124	26	2	0	0	0	0	515
04:30 PM	63	285	0	1	26	0	17	0	0	123	16	2	0	0	0	1	534
04:45 PM	63	281	0	0	11	0	22	0	0	157	23	0	0	0	0	0	557
<b>Total</b>	<b>236</b>	<b>1071</b>	<b>0</b>	<b>1</b>	<b>71</b>	<b>0</b>	<b>87</b>	<b>0</b>	<b>0</b>	<b>553</b>	<b>85</b>	<b>4</b>	<b>0</b>	<b>0</b>	<b>0</b>	<b>1</b>	<b>2109</b>
05:00 PM	69	250	0	0	18	0	18	2	0	149	20	0	0	1	0	0	527
05:15 PM	72	340	0	2	27	0	22	1	0	172	22	0	0	0	0	0	658
05:30 PM	91	314	3	0	16	0	26	0	0	155	15	1	0	0	0	0	621
05:45 PM	83	294	0	1	23	1	20	1	0	109	27	1	0	0	0	1	561
<b>Total</b>	<b>315</b>	<b>1198</b>	<b>3</b>	<b>3</b>	<b>84</b>	<b>1</b>	<b>86</b>	<b>4</b>	<b>0</b>	<b>585</b>	<b>84</b>	<b>2</b>	<b>0</b>	<b>1</b>	<b>0</b>	<b>1</b>	<b>2367</b>
<b>Grand Total</b>	<b>691</b>	<b>3096</b>	<b>3</b>	<b>13</b>	<b>354</b>	<b>3</b>	<b>675</b>	<b>11</b>	<b>0</b>	<b>3202</b>	<b>368</b>	<b>15</b>	<b>0</b>	<b>1</b>	<b>0</b>	<b>3</b>	<b>8435</b>
Apprch %	18.2	81.4	0.1	0.3	33.9	0.3	64.7	1.1	0	89.3	10.3	0.4	0	25	0	75	
Total %	8.2	36.7	0	0.2	4.2	0	8	0.1	0	38	4.4	0.2	0	0	0	0	



# Southern Traffic Services, Inc.

2911 Westfield Rd  
 Gulf Breeze, FL 32563  
 1-800-786-3374

*Traffic is our only business!*

US 41 @ Symmes Rd  
 Tampa, FL

File Name : 13015-4 us 41 @ symmes rd  
 Site Code : 13015-4  
 Start Date : 1/9/2013  
 Page No : 2

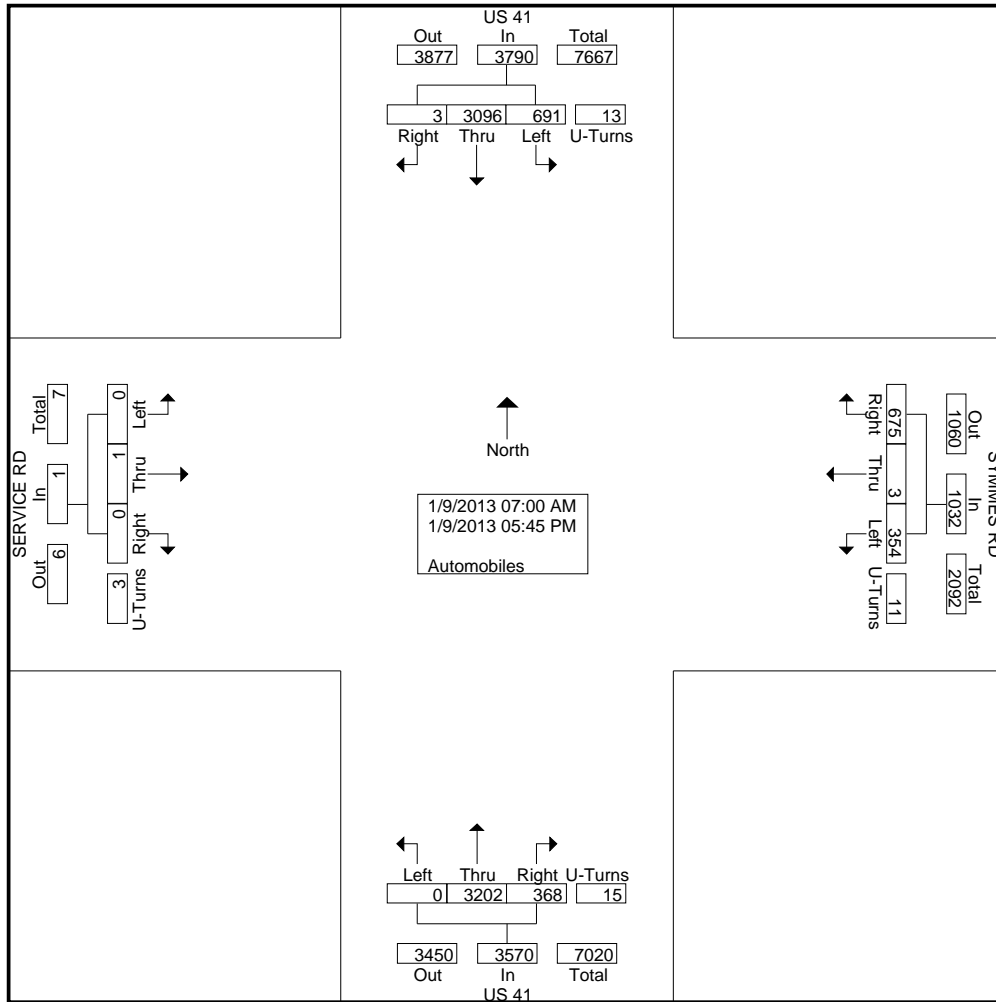



# Southern Traffic Services, Inc.

2911 Westfield Rd  
 Gulf Breeze, FL 32563  
 1-800-786-3374

*Traffic is our only business!*

US 41 @ Symmes Rd  
 Tampa, FL

File Name : 13015-4 us 41 @ symmes rd  
 Site Code : 13015-4  
 Start Date : 1/9/2013  
 Page No : 3

Start Time	US 41 Southbound				SYMMES RD Westbound				US 41 Northbound				SERVICE RD Eastbound				Int. Total				
	Thru	Right	U-Turns	App. Total	Left	Thru	Right	U-Turns	App. Total	Left	Thru	Right	U-Turns	App. Total	Left	Thru		Right	U-Turns	App. Total	
Peak Hour Analysis From 07:00 AM to 11:45 AM - Peak 1 of 1																					
Peak Hour for Entire Intersection Begins at 07:00 AM																					
07:00 AM	18	101	0	0	119	20	0	70	0	90	0	301	25	2	328	0	0	0	0	0	537
07:15 AM	18	106	0	0	124	28	0	93	0	121	0	270	40	2	312	0	0	0	0	0	557
07:30 AM	23	120	0	1	144	41	0	88	2	131	0	361	37	3	401	0	0	0	1	1	677
07:45 AM	14	109	0	0	123	36	0	57	0	93	0	309	29	0	338	0	0	0	0	0	554
Total Volume	73	436	0	1	510	125	0	308	2	435	0	1241	131	7	1379	0	0	0	1	1	2325
% App. Total	14.3	85.5	0	0.2		28.7	0	70.8	0.5		0	90	9.5	0.5		0	0	0	100		
PHF	.793	.908	.000	.250	.885	.762	.000	.828	.250	.830	.000	.859	.819	.583	.860	.000	.000	.000	.250	.250	.859

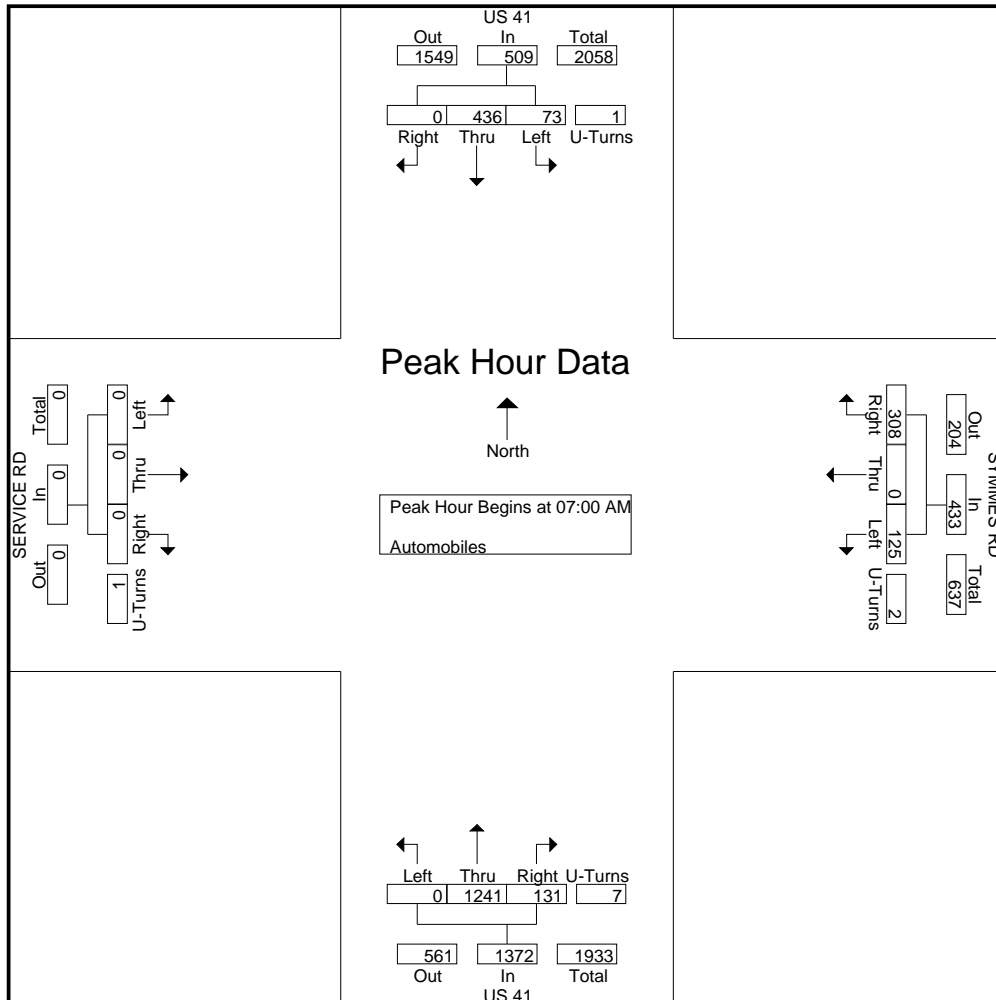



# Southern Traffic Services, Inc.

2911 Westfield Rd  
Gulf Breeze, FL 32563  
1-800-786-3374

*Traffic is our only business!*

US 41 @ Symmes Rd  
Tampa, FL

File Name : 13015-4 us 41 @ symmes rd  
Site Code : 13015-4  
Start Date : 1/9/2013  
Page No : 4

Start Time	US 41 Southbound					SYMMES RD Westbound					US 41 Northbound					SERVICE RD Eastbound					Int. Total
	Left	Thru	Right	U-Turns	App. Total	Left	Thru	Right	U-Turns	App. Total	Left	Thru	Right	U-Turns	App. Total	Left	Thru	Right	U-Turns	App. Total	
Peak Hour Analysis From 12:00 PM to 05:45 PM - Peak 1 of 1																					
Peak Hour for Entire Intersection Begins at 05:00 PM																					
05:00 PM	69	250	0	0	319	18	0	18	2	38	0	149	20	0	169	0	1	0	0	1	527
05:15 PM	72	340	0	2	414	27	0	22	1	50	0	172	22	0	194	0	0	0	0	0	658
05:30 PM	91	314	3	0	408	16	0	26	0	42	0	155	15	1	171	0	0	0	0	0	621
05:45 PM	83	294	0	1	378	23	1	20	1	45	0	109	27	1	137	0	0	0	1	1	561
Total Volume	315	1198	3	3	1519	84	1	86	4	175	0	585	84	2	671	0	1	0	1	2	2367
% App. Total	20.7	78.9	0.2	0.2		48	0.6	49.1	2.3		0	87.2	12.5	0.3		0	50	0	50		
PHF	.865	.881	.250	.375	.917	.778	.250	.827	.500	.875	.000	.850	.778	.500	.865	.000	.250	.000	.250	.500	.899

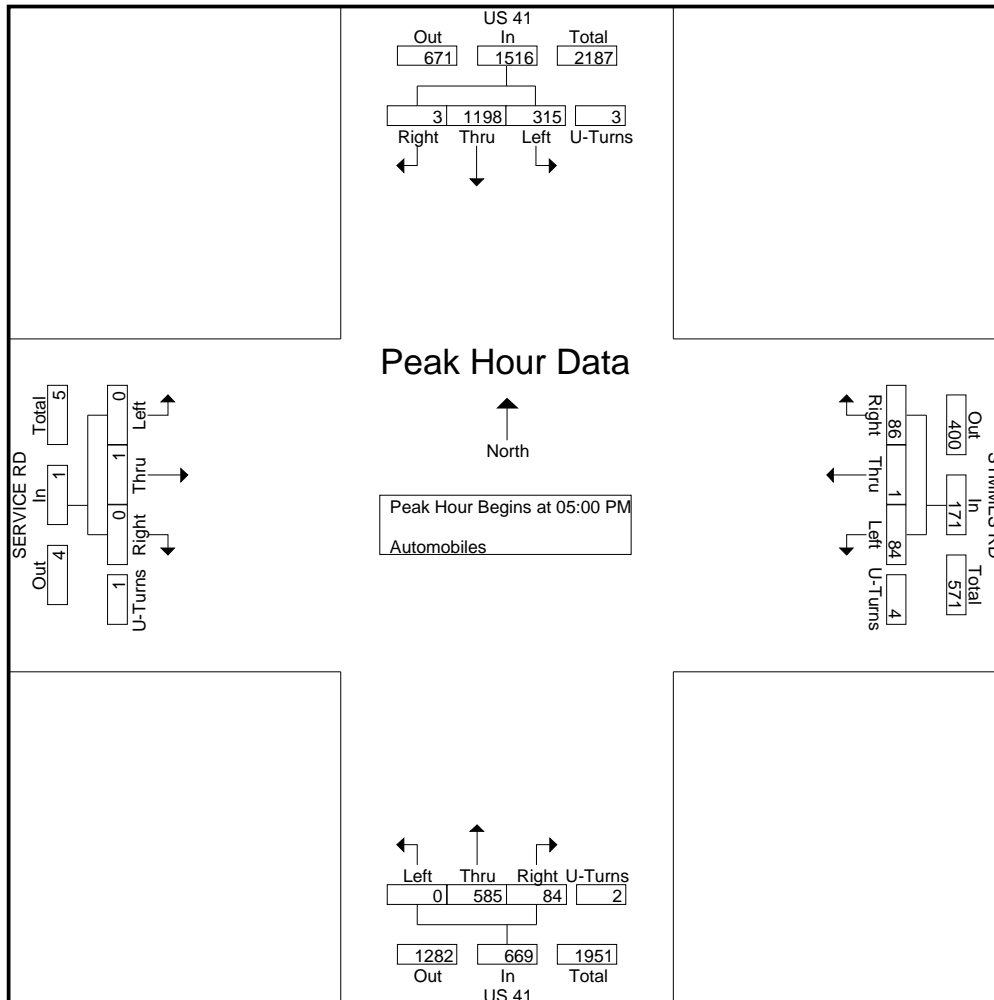





# Southern Traffic Services, Inc.

2911 Westfield Rd  
 Gulf Breeze, FL 32563  
 1-800-786-3374  
*Traffic is our only business!*

US 41 @ Symmes Rd  
 Tampa, FL

File Name : 13015-4 us 41 @ symmes rd  
 Site Code : 13015-4  
 Start Date : 1/9/2013  
 Page No : 2

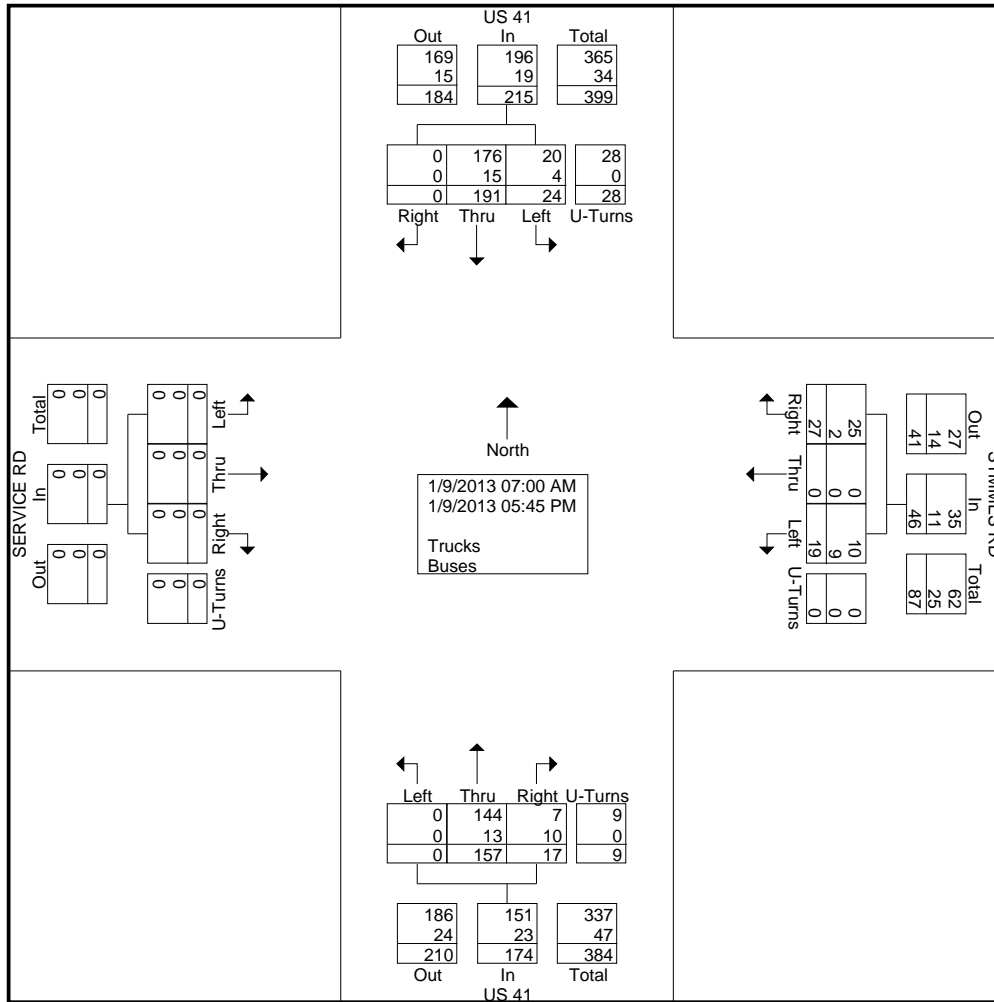



# Southern Traffic Services, Inc.

2911 Westfield Rd  
 Gulf Breeze, FL 32563  
 1-800-786-3374

*Traffic is our only business!*

US 41 @ Symmes Rd  
 Tampa, FL

File Name : 13015-4 us 41 @ symmes rd  
 Site Code : 13015-4  
 Start Date : 1/9/2013  
 Page No : 3

Start Time	US 41 Southbound				SYMMES RD Westbound				US 41 Northbound				SERVICE RD Eastbound				Int. Total			
	Thru	Right	U-Turns	App. Total	Left	Thru	Right	U-Turns	App. Total	Left	Thru	Right	U-Turns	App. Total	Left	Thru		Right	U-Turns	App. Total
Peak Hour Analysis From 07:00 AM to 11:45 AM - Peak 1 of 1																				
Peak Hour for Entire Intersection Begins at 07:30 AM																				
07:30 AM	2	15	0	17	5	0	4	0	9	0	6	0	3	9	0	0	0	0	0	35
07:45 AM	5	18	0	25	1	0	3	0	4	0	9	1	1	11	0	0	0	0	0	40
08:00 AM	1	15	0	16	0	0	1	0	1	0	17	2	0	19	0	0	0	0	0	36
08:15 AM	3	19	0	24	1	0	1	0	2	0	12	0	1	13	0	0	0	0	0	39
Total Volume	11	67	0	82	7	0	9	0	16	0	44	3	5	52	0	0	0	0	0	150
% App. Total	13.4	81.7	0	4.9	43.8	0	56.2	0		0	84.6	5.8	9.6		0	0	0	0	0	
PHF	.550	.882	.000	.500	.820	.350	.000	.563	.000	.444	.000	.647	.375	.417	.684	.000	.000	.000	.000	.938

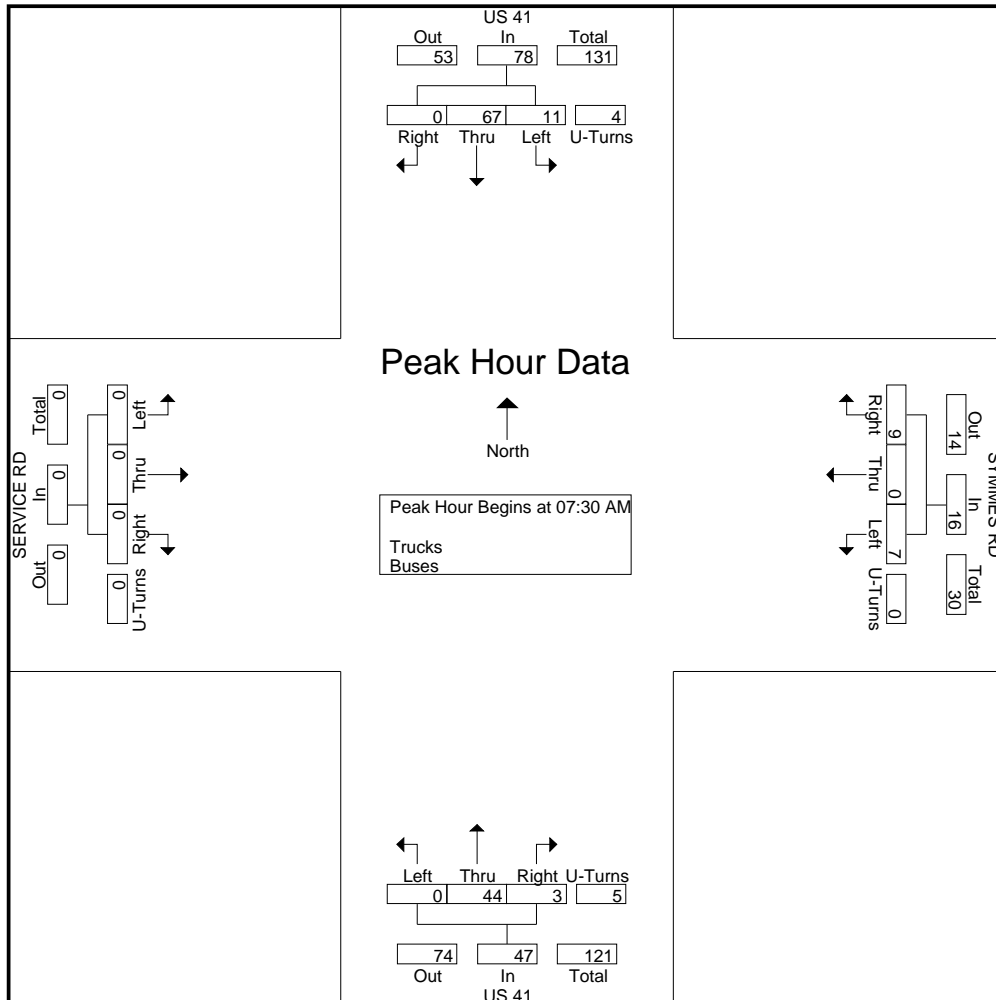





# Southern Traffic Services, Inc.

2911 Westfield Rd  
 Gulf Breeze, FL 32563  
 1-800-786-3374

*Traffic is our only business!*

US 41 @ Symmes Rd  
 Tampa, FL

File Name : 13015-4 us 41 @ symmes rd  
 Site Code : 13015-4  
 Start Date : 1/9/2013  
 Page No : 4

Start Time	US 41 Southbound					SYMMES RD Westbound					US 41 Northbound					SERVICE RD Eastbound					Int. Total
	Left	Thru	Right	U-Turns	App. Total	Left	Thru	Right	U-Turns	App. Total	Left	Thru	Right	U-Turns	App. Total	Left	Thru	Right	U-Turns	App. Total	
Peak Hour Analysis From 12:00 PM to 05:45 PM - Peak 1 of 1																					
Peak Hour for Entire Intersection Begins at 04:00 PM																					
04:00 PM	2	11	0	3	16	0	0	2	0	2	0	11	1	1	13	0	0	0	0	0	31
04:15 PM	3	12	0	2	17	1	0	1	0	2	0	12	5	0	17	0	0	0	0	0	36
04:30 PM	3	6	0	1	10	0	0	3	0	3	0	12	1	0	13	0	0	0	0	0	26
04:45 PM	2	4	0	4	10	2	0	1	0	3	0	14	0	1	15	0	0	0	0	0	28
Total Volume	10	33	0	10	53	3	0	7	0	10	0	49	7	2	58	0	0	0	0	0	121
% App. Total	18.9	62.3	0	18.9		30	0	70	0		0	84.5	12.1	3.4		0	0	0	0		
PHF	.833	.688	.000	.625	.779	.375	.000	.583	.000	.833	.000	.875	.350	.500	.853	.000	.000	.000	.000	.000	.840

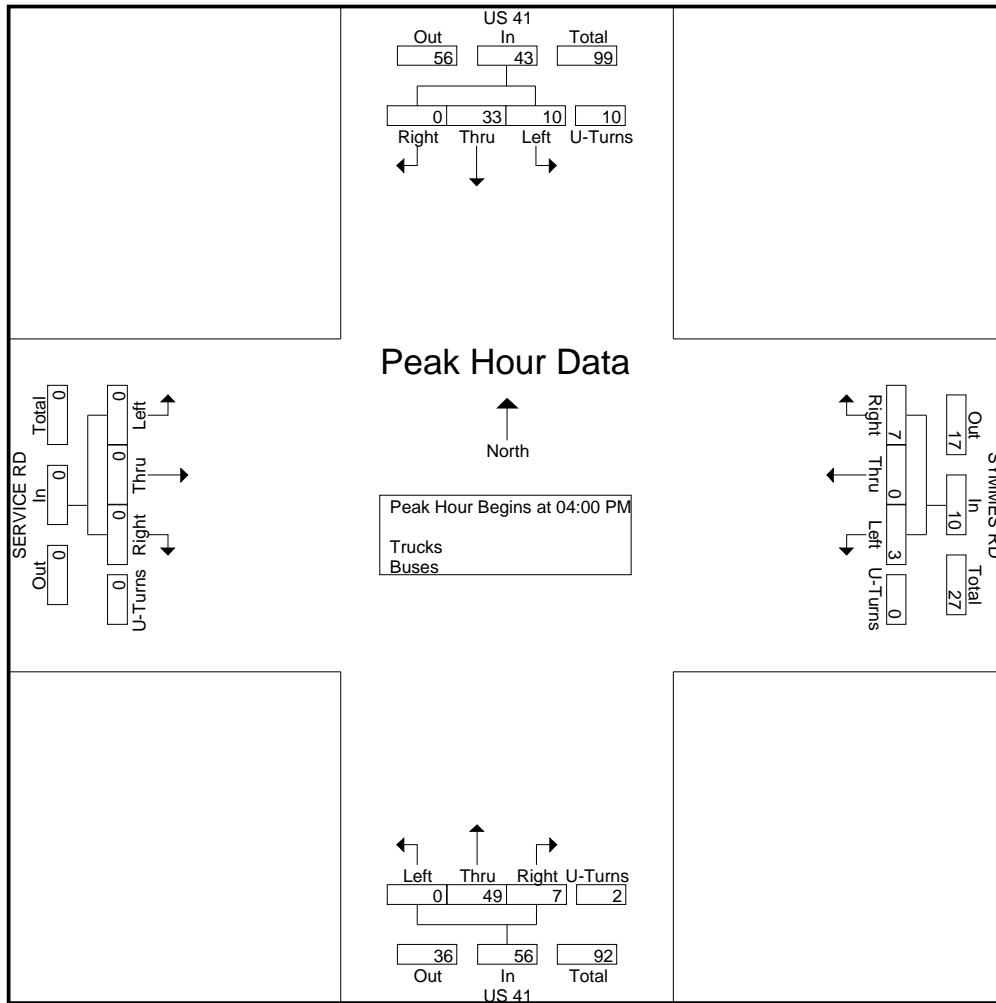



# Southern Traffic Services, Inc.

2911 Westfield Rd  
Gulf Breeze, FL 32563  
1-800-786-3374

*Traffic is our only business!*

US 41 @ Symmes Rd  
Tampa, FL

File Name : 13015-4 US 41 @ Symmes Rd Peds  
Site Code : 13015-4  
Start Date : 1/9/2013  
Page No : 1

### Groups Printed- Peds

Start Time	US 41	SYMMES RD	US 41	SERVICE RD	Int. Total
	Southbound	Westbound	Northbound	Eastbound	
	Peds	Peds	Peds	Peds	
07:00 AM	0	0	2	0	2
07:15 AM	0	0	2	0	2
07:30 AM	1	2	3	1	7
07:45 AM	0	0	0	0	0
Total	1	2	7	1	11
08:00 AM	2	1	0	0	3
08:15 AM	1	1	0	0	2
08:30 AM	3	0	1	0	4
08:45 AM	2	3	1	0	6
Total	8	5	2	0	15
09:00 AM	0	0	0	0	0
09:15 AM	0	0	0	0	0
09:30 AM	0	0	0	0	0
09:45 AM	0	0	0	0	0
Total	0	0	0	0	0
10:00 AM	0	0	0	0	0
10:15 AM	0	0	0	0	0
10:30 AM	0	0	0	0	0
10:45 AM	0	0	0	0	0
Total	0	0	0	0	0
11:00 AM	0	0	0	0	0
11:15 AM	0	0	0	0	0
11:30 AM	0	0	0	0	0
11:45 AM	0	0	0	0	0
Total	0	0	0	0	0
12:00 PM	0	0	0	0	0
12:15 PM	0	0	0	0	0
12:30 PM	0	0	0	0	0
12:45 PM	0	0	0	0	0
Total	0	0	0	0	0
01:00 PM	0	0	0	0	0
01:15 PM	0	0	0	0	0
01:30 PM	0	0	0	0	0
01:45 PM	0	0	0	0	0
Total	0	0	0	0	0
02:00 PM	0	0	0	0	0
02:15 PM	0	0	0	0	0
02:30 PM	0	0	0	0	0
02:45 PM	0	0	0	0	0
Total	0	0	0	0	0
03:00 PM	0	0	0	0	0
03:15 PM	0	0	0	0	0
03:30 PM	0	0	0	0	0
03:45 PM	0	0	0	0	0
Total	0	0	0	0	0



# Southern Traffic Services, Inc.

2911 Westfield Rd  
 Gulf Breeze, FL 32563  
 1-800-786-3374

*Traffic is our only business!*

US 41 @ Symmes Rd  
 Tampa, FL

File Name : 13015-4 US 41 @ Symmes Rd Peds  
 Site Code : 13015-4  
 Start Date : 1/9/2013  
 Page No : 2

Groups Printed- Peds

Start Time	US 41 Southbound	SYMMES RD Westbound	US 41 Northbound	SERVICE RD Eastbound	Int. Total
	Peds	Peds	Peds	Peds	
04:00 PM	0	0	0	0	0
04:15 PM	0	0	2	0	2
04:30 PM	1	0	2	1	4
04:45 PM	0	0	0	0	0
Total	1	0	4	1	6
05:00 PM	0	2	0	0	2
05:15 PM	2	1	0	0	3
05:30 PM	0	0	1	0	1
05:45 PM	1	1	1	1	4
Total	3	4	2	1	10
Grand Total	13	11	15	3	42
Apprch %	100	100	100	100	
Total %	31	26.2	35.7	7.1	

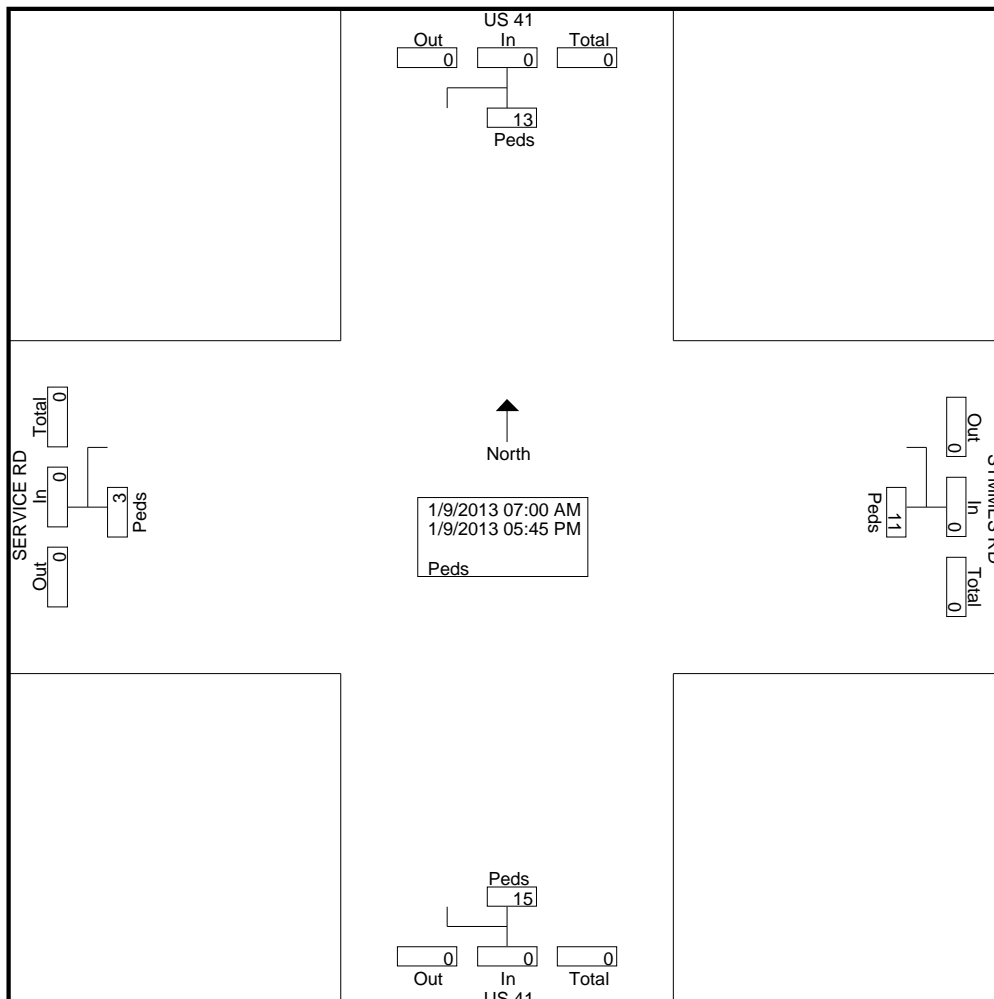

# Southern Traffic Services, Inc.

## Event Counts

**US 41 north of Symmes Road**

**Northbound**

**Datasets:**

**Site:** [041] !C7006  
**Input A:** 7 - North bound A>B, South bound B>A. - Excluded from totals. (0)  
**Input B:** 0 - Unused or unknown. - Added to totals. (1)  
**Survey Duration:** 14:39 Monday, January 07, 2013 => 11:19 Friday, January 11, 2013  
**File:** G:\DATA\2013\Private\13015\marco\Jan -11-2013 DATA\UM041.eco (Plus)  
**Identifier:** U6090XCH MC56-L5 [MC55] (c)Microcom 19Oct04  
**Algorithm:** Event Count  
**Data type:** Axle sensors - Paired (Class, Speed, Count)

**Profile:**

**Filter time:** 0:00 Tuesday, January 08, 2013 => 0:00 Friday, January 11, 2013  
**Name:** Factory default profile  
**Scheme:** Count events divided by two.  
**Units:** Non metric (ft, mi, ft/s, mph, lb, ton)  
**In profile:** Events = 41570

**Tuesday, January 08, 2013=13808, 15 minute drops**

0000	0100	0200	0300	0400	0500	0600	0700	0800	0900	1000	1100	1200	1300	1400	1500	1600	1700	1800	1900	2000	2100	2200	2300	
53	29	26	78	177	590	1400	1728	1154	787	677	701	739	777	796	887	790	815	546	353	252	210	132	111	
13	7	8	18	24	97	256	403	349	142	155	181	174	192	172	220	208	211	152	97	53	54	36	32	13
12	9	4	17	34	131	346	453	327	232	185	176	178	209	217	212	166	204	153	118	58	55	36	24	16
18	8	8	25	59	158	372	488	256	214	179	160	179	190	215	242	201	216	145	80	75	44	30	37	17
10	5	6	18	60	204	426	384	222	199	158	184	208	186	192	213	215	184	96	58	66	57	30	18	14

AM Peak 0645 - 0745 (1770), AM PHF=0.91 PM Peak 1500 - 1600 (887), PM PHF=0.92

**Wednesday, January 09, 2013=13933, 15 minute drops**

0000	0100	0200	0300	0400	0500	0600	0700	0800	0900	1000	1100	1200	1300	1400	1500	1600	1700	1800	1900	2000	2100	2200	2300	
60	39	41	82	174	626	1335	1703	1137	816	744	680	737	756	785	864	792	837	627	351	250	240	153	104	
13	11	13	19	19	101	246	395	353	227	201	180	170	219	216	203	204	241	175	117	64	81	49	33	14
16	12	8	22	44	126	352	420	320	192	179	159	189	179	196	183	185	219	153	79	84	64	40	22	12
17	10	8	24	50	178	373	488	251	202	188	175	185	184	182	266	195	225	146	82	51	46	36	23	10
14	6	12	17	61	221	364	400	213	195	176	166	193	174	191	212	208	152	153	73	51	49	28	26	11

AM Peak 0700 - 0800 (1703), AM PHF=0.87 PM Peak 1645 - 1745 (893), PM PHF=0.93

**Thursday, January 10, 2013=13829, 15 minute drops**

0000	0100	0200	0300	0400	0500	0600	0700	0800	0900	1000	1100	1200	1300	1400	1500	1600	1700	1800	1900	2000	2100	2200	2300	
47	44	38	64	164	596	1313	1719	1135	771	668	742	694	755	805	914	797	792	614	348	316	240	165	88	
14	9	9	13	25	98	239	429	344	202	160	186	172	183	202	193	200	211	177	89	75	60	44	21	14
12	9	10	17	34	121	304	422	322	200	204	201	183	193	181	221	187	209	156	109	92	67	38	22	18
10	17	9	22	57	165	418	475	249	195	56	181	174	195	234	279	197	192	143	78	71	60	40	34	10
11	9	10	12	48	212	352	393	220	174	248	174	165	184	188	221	213	180	138	72	78	53	43	11	19

AM Peak 0700 - 0800 (1719), AM PHF=0.90 PM Peak 1515 - 1615 (921), PM PHF=0.83

# Southern Traffic Services, Inc.

## Event Counts

**US 41 north of Symmes Road**

**Southbound**

**Datasets:**

**Site:** [041] !C7006  
**Input A:** 7 - North bound A>B, South bound B>A. - Added to totals. (1)  
**Input B:** 0 - Unused or unknown. - Excluded from totals. (0)  
**Survey Duration:** 14:39 Monday, January 07, 2013 => 11:19 Friday, January 11, 2013  
**File:** G:\DATA\2013\Private\13015\marco\Jan -11-2013 DATA\UM041.eco (Plus)  
**Identifier:** U6090XCH MC56-L5 [MC55] (c)Microcom 19Oct04  
**Algorithm:** Event Count  
**Data type:** Axle sensors - Paired (Class, Speed, Count)

**Profile:**

**Filter time:** 0:00 Tuesday, January 08, 2013 => 0:00 Friday, January 11, 2013  
**Name:** Factory default profile  
**Scheme:** Count events divided by two.  
**Units:** Non metric (ft, mi, ft/s, mph, lb, ton)  
**In profile:** Events = 41419

**Tuesday, January 08, 2013=13754, 15 minute drops**

0000	0100	0200	0300	0400	0500	0600	0700	0800	0900	1000	1100	1200	1300	1400	1500	1600	1700	1800	1900	2000	2100	2200	2300	
165	64	46	71	105	201	530	609	562	551	547	636	653	703	730	1112	1457	1727	1264	672	518	367	277	187	
50	16	7	16	16	28	117	154	134	125	120	145	167	170	161	170	352	395	391	188	137	88	94	49	29
71	16	11	12	27	40	126	158	150	141	139	153	176	126	225	266	337	490	352	167	155	100	74	53	39
27	16	18	25	29	61	150	133	158	137	142	176	137	253	164	349	371	445	271	156	125	83	66	47	15
17	16	10	18	33	72	137	164	120	148	146	162	173	154	180	327	397	397	250	161	101	96	43	38	18

AM Peak 1130 - 1230 (681), AM PHF=0.97 PM Peak 1645 - 1745 (1727), PM PHF=0.88

**Wednesday, January 09, 2013=13826, 15 minute drops**

0000	0100	0200	0300	0400	0500	0600	0700	0800	0900	1000	1100	1200	1300	1400	1500	1600	1700	1800	1900	2000	2100	2200	2300	
101	76	59	46	79	241	547	641	611	546	598	577	686	693	764	1092	1416	1673	1211	653	529	429	338	220	
29	24	16	7	12	25	113	158	134	139	152	147	185	188	174	222	342	386	395	177	146	114	99	53	34
39	17	16	17	22	34	136	147	163	143	148	174	152	159	189	248	344	472	332	124	135	112	86	44	32
15	23	18	13	18	83	159	174	161	114	145	149	181	171	188	318	369	412	249	215	127	114	88	79	28
18	12	9	9	27	99	139	162	153	150	153	107	168	175	213	304	361	403	235	137	121	89	65	44	31

AM Peak 0700 - 0800 (641), AM PHF=0.92 PM Peak 1715 - 1815 (1682), PM PHF=0.89

**Thursday, January 10, 2013=13839, 15 minute drops**

0000	0100	0200	0300	0400	0500	0600	0700	0800	0900	1000	1100	1200	1300	1400	1500	1600	1700	1800	1900	2000	2100	2200	2300	
125	87	64	44	84	209	541	619	492	564	534	598	679	674	858	1108	1431	1718	1222	736	541	390	307	214	
34	25	16	10	11	33	116	158	93	170	126	142	153	161	181	219	342	407	348	248	147	113	70	18	38
32	23	14	10	17	34	152	165	169	122	131	151	186	178	242	276	354	438	312	197	141	114	84	94	46
28	21	20	13	29	63	158	158	132	144	126	148	168	116	190	289	341	488	290	155	135	87	78	55	31
31	18	14	11	27	79	115	138	98	128	151	157	172	219	245	324	394	385	272	136	118	76	75	47	23

AM Peak 1145 - 1245 (664), AM PHF=0.89 PM Peak 1645 - 1745 (1727), PM PHF=0.88

# Southern Traffic Services, Inc.

## Event Counts

**US 41 south of Symmes Road**

**Northbound**

**Datasets:**

**Site:** [042] I4231  
**Input A:** 7 - North bound A>B, South bound B>A. - Excluded from totals. (0)  
**Input B:** 0 - Unused or unknown. - Added to totals. (1)  
**Survey Duration:** 14:36 Monday, January 07, 2013 => 11:33 Friday, January 11, 2013  
**File:** G:\DATA\2013\Private\13015\marco\Jan -11-2013 DATA\UM042.eco (Base)  
**Identifier:** P298D421 MC56-L4 [MC55] (c)Microcom 19Sep03  
**Algorithm:** Event Count  
**Data type:** Axle sensors - Paired (Class, Speed, Count)

**Profile:**

**Filter time:** 0:00 Tuesday, January 08, 2013 => 0:00 Friday, January 11, 2013  
**Name:** Factory default profile  
**Scheme:** Count events divided by two.  
**Units:** Non metric (ft, mi, ft/s, mph, lb, ton)  
**In profile:** Events = 38201

**Tuesday, January 08, 2013=12683, 15 minute drops**

0000	0100	0200	0300	0400	0500	0600	0700	0800	0900	1000	1100	1200	1300	1400	1500	1600	1700	1800	1900	2000	2100	2200	2300	
51	28	22	60	142	485	1202	1531	1020	720	641	657	689	710	801	884	770	813	503	314	231	192	119	98	
9	8	7	17	21	79	234	354	309	136	158	170	159	167	173	211	196	203	145	90	43	50	32	26	16
17	8	5	14	22	112	295	395	289	208	173	171	173	196	216	217	166	218	145	103	55	51	31	27	20
16	6	5	17	47	126	298	414	218	200	158	151	170	175	222	241	199	217	120	76	70	47	28	31	20
9	6	5	12	52	168	375	368	204	176	152	165	187	172	190	215	209	175	93	45	63	44	28	14	13

AM Peak 0645 - 0745 (1538), AM PHF=0.93 PM Peak 1500 - 1600 (884), PM PHF=0.92

**Wednesday, January 09, 2013=12817, 15 minute drops**

0000	0100	0200	0300	0400	0500	0600	0700	0800	0900	1000	1100	1200	1300	1400	1500	1600	1700	1800	1900	2000	2100	2200	2300	
69	32	41	57	137	526	1130	1533	1019	739	689	639	688	723	744	851	788	811	566	325	251	225	137	97	
16	9	12	16	16	84	207	357	323	201	168	159	147	218	184	209	203	218	172	114	66	73	46	34	14
20	11	10	16	38	104	292	350	278	166	182	156	178	157	190	168	188	217	139	82	77	59	32	20	15
20	7	10	14	35	151	304	454	221	187	175	158	175	177	182	263	192	214	123	70	48	49	32	25	6
13	5	9	11	48	187	327	372	197	185	164	166	188	171	188	211	205	162	132	59	60	44	27	18	7

AM Peak 0700 - 0800 (1533), AM PHF=0.84 PM Peak 1530 - 1630 (865), PM PHF=0.82

**Thursday, January 10, 2013=12701, 15 minute drops**

0000	0100	0200	0300	0400	0500	0600	0700	0800	0900	1000	1100	1200	1300	1400	1500	1600	1700	1800	1900	2000	2100	2200	2300	
42	42	31	49	135	489	1121	1532	1005	683	634	710	646	697	771	907	784	768	591	331	297	211	141	84	
14	9	6	12	21	79	208	362	298	166	156	162	157	166	187	185	186	194	174	82	63	54	37	22	15
15	10	9	14	32	99	255	356	279	180	186	202	165	179	196	213	183	216	154	101	88	63	33	17	17
6	16	10	14	37	138	362	453	229	184	38	176	159	178	221	279	213	192	133	62	72	46	37	33	9
7	7	6	9	45	173	296	361	199	153	254	170	165	174	167	230	202	166	130	86	74	48	34	12	17

AM Peak 0700 - 0800 (1532), AM PHF=0.85 PM Peak 1515 - 1615 (908), PM PHF=0.81

# Southern Traffic Services, Inc.

## Event Counts

**US 41 south of Symmes Road**

**Southbound**

**Datasets:**

**Site:** [042] I4231  
**Input A:** 7 - North bound A>B, South bound B>A. - Added to totals. (1)  
**Input B:** 0 - Unused or unknown. - Excluded from totals. (0)  
**Survey Duration:** 14:36 Monday, January 07, 2013 => 11:33 Friday, January 11, 2013  
**File:** G:\DATA\2013\Private\13015\marco\Jan -11-2013 DATA\UM042.eco (Base)  
**Identifier:** P298D421 MC56-L4 [MC55] (c)Microcom 19Sep03  
**Algorithm:** Event Count  
**Data type:** Axle sensors - Paired (Class, Speed, Count)

**Profile:**

**Filter time:** 0:00 Tuesday, January 08, 2013 => 0:00 Friday, January 11, 2013  
**Name:** Factory default profile  
**Scheme:** Count events divided by two.  
**Units:** Non metric (ft, mi, ft/s, mph, lb, ton)  
**In profile:** Events = 37989

**Tuesday, January 08, 2013=12661, 15 minute drops**

0000	0100	0200	0300	0400	0500	0600	0700	0800	0900	1000	1100	1200	1300	1400	1500	1600	1700	1800	1900	2000	2100	2200	2300	
134	49	44	59	104	206	544	692	563	567	538	634	614	659	703	1000	1262	1459	1082	563	461	326	247	151	
45	13	8	13	16	22	116	158	137	125	121	146	168	154	171	154	315	347	331	152	131	76	84	37	24
60	12	8	11	27	42	134	174	152	147	138	158	158	118	205	250	272	376	319	132	134	88	72	39	31
19	13	18	17	29	69	147	179	155	144	137	168	129	237	163	300	354	374	243	137	104	76	56	44	14
10	11	10	18	32	73	147	181	119	151	142	162	159	150	164	296	321	362	189	142	92	86	35	31	12

AM Peak 0700 - 0800 (692), AM PHF=0.96 PM Peak 1700 - 1800 (1459), PM PHF=0.97

**Wednesday, January 09, 2013=12722, 15 minute drops**

0000	0100	0200	0300	0400	0500	0600	0700	0800	0900	1000	1100	1200	1300	1400	1500	1600	1700	1800	1900	2000	2100	2200	2300	
81	58	53	41	71	245	568	712	619	534	600	578	649	639	728	990	1242	1451	1010	592	442	370	281	168	
24	15	15	6	10	22	121	164	137	136	150	146	172	180	166	193	298	330	332	164	124	92	85	45	24
31	16	14	16	17	36	131	161	170	135	155	157	145	132	188	238	284	429	275	118	106	104	66	36	24
14	17	17	11	16	90	168	200	163	116	148	155	174	169	180	272	350	344	213	184	104	95	68	56	25
12	10	7	8	28	97	148	187	149	147	147	120	158	158	194	287	310	348	190	126	108	79	62	31	24

AM Peak 0700 - 0800 (712), AM PHF=0.89 PM Peak 1715 - 1815 (1453), PM PHF=0.85

**Thursday, January 10, 2013=12606, 15 minute drops**

0000	0100	0200	0300	0400	0500	0600	0700	0800	0900	1000	1100	1200	1300	1400	1500	1600	1700	1800	1900	2000	2100	2200	2300	
97	70	52	42	85	226	554	737	503	549	506	570	623	647	780	995	1224	1453	1033	626	474	323	264	173	
24	16	11	10	11	32	107	163	96	158	113	144	155	151	159	216	294	348	278	198	144	90	66	15	32
24	17	13	10	19	40	160	191	161	117	121	136	165	173	231	225	315	376	268	166	113	98	73	78	38
25	20	19	12	27	60	157	196	149	142	128	144	142	112	178	269	275	400	256	136	107	65	66	43	26
24	17	9	10	28	94	130	187	97	132	144	146	161	211	212	285	340	329	231	126	110	70	59	37	20

AM Peak 0700 - 0800 (737), AM PHF=0.94 PM Peak 1645 - 1745 (1464), PM PHF=0.92

# Southern Traffic Services, Inc.

## Event Counts

**Symmes Road east of US 41**

**Eastbound**

**Datasets:**

**Site:** [043] IC7032  
**Input A:** 2 - East bound, A hit first. - Added to totals. (1)  
**Input B:** 0 - Unused or unknown. - Excluded from totals. (0)  
**Survey Duration:** 14:39 Monday, January 07, 2013 => 11:22 Friday, January 11, 2013  
**File:** G:\DATA\2013\Private\13015\marco\Jan -11-2013 DATA\UM043 EB.eco (Plus)  
**Identifier:** U485TDPH MC56-L5 [MC55] (c)Microcom 19Oct04  
**Algorithm:** Event Count  
**Data type:** Axle sensors - Paired (Class, Speed, Count)

**Profile:**

**Filter time:** 0:00 Tuesday, January 08, 2013 => 0:00 Friday, January 11, 2013  
**Name:** Factory default profile  
**Scheme:** Count events divided by two.  
**Units:** Non metric (ft, mi, ft/s, mph, lb, ton)  
**In profile:** Events = 10576

**Tuesday, January 08, 2013=3499, 15 minute drops**

0000	0100	0200	0300	0400	0500	0600	0700	0800	0900	1000	1100	1200	1300	1400	1500	1600	1700	1800	1900	2000	2100	2200	2300	
45	22	11	14	8	27	101	154	124	108	122	115	157	170	227	288	404	497	356	201	139	89	67	53	
9	5	1	3	2	5	19	36	29	22	35	26	34	46	42	45	92	114	113	73	28	25	24	15	9
18	6	6	2	1	5	25	33	33	27	35	27	39	35	60	76	99	150	87	39	45	24	13	17	18
11	5	2	8	3	8	22	31	34	29	24	33	41	45	70	78	96	133	70	48	37	18	18	11	6
7	6	2	1	2	9	35	54	28	30	28	29	43	44	55	89	117	100	86	41	29	22	12	10	7

AM Peak 0700 - 0800 (154), AM PHF=0.71 PM Peak 1645 - 1745 (514), PM PHF=0.86

**Wednesday, January 09, 2013=3536, 15 minute drops**

0000	0100	0200	0300	0400	0500	0600	0700	0800	0900	1000	1100	1200	1300	1400	1500	1600	1700	1800	1900	2000	2100	2200	2300	
40	23	16	8	15	32	107	185	143	113	121	126	164	172	201	271	381	464	366	166	148	126	78	70	
9	10	2	1	2	6	17	40	42	26	19	30	38	40	47	54	94	113	113	46	40	41	24	17	13
18	4	5	3	9	4	28	41	40	31	40	37	43	40	51	66	100	121	101	31	38	33	23	12	11
6	7	6	2	1	9	32	54	29	28	28	38	41	47	57	82	91	118	79	53	42	33	21	27	3
7	2	3	2	3	13	30	50	32	28	34	21	42	45	46	69	96	112	73	36	28	19	10	14	6

AM Peak 0715 - 0815 (187), AM PHF=0.87 PM Peak 1700 - 1800 (464), PM PHF=0.96

**Thursday, January 10, 2013=3541, 15 minute drops**

0000	0100	0200	0300	0400	0500	0600	0700	0800	0900	1000	1100	1200	1300	1400	1500	1600	1700	1800	1900	2000	2100	2200	2300	
33	25	15	8	12	26	96	182	127	105	103	123	165	135	242	299	400	467	365	204	156	119	70	64	
13	10	5	3	2	5	19	34	39	32	18	28	31	37	49	50	81	110	115	70	26	37	14	9	9
11	9	1	1	2	4	24	50	36	24	27	35	51	31	70	72	92	130	92	53	43	30	19	21	8
3	4	3	3	4	11	30	47	28	20	26	26	42	26	60	85	117	118	88	43	52	34	21	16	8
6	2	6	1	4	6	23	51	24	29	32	34	41	41	63	92	110	109	70	38	35	18	16	18	7

AM Peak 0715 - 0815 (187), AM PHF=0.92 PM Peak 1715 - 1815 (472), PM PHF=0.91



# Southern Traffic Services, Inc.

## Event Counts

**Symmes Road east of US 41**

**Westbound**

**Datasets:**

**Site:** [043] IMA.c6537  
**Input A:** 4 - West bound, A hit first. - Added to totals. (1)  
**Input B:** 0 - Unused or unknown. - Excluded from totals. (0)  
**Survey Duration:** 14:37 Monday, January 07, 2013 => 11:24 Friday, January 11, 2013  
**File:** G:\DATA\2013\Private\13015\marco\Jan -11-2013 DATA\UM043 WB.eco (Plus)  
**Identifier:** T683E26M MC56-L5 [MC55] (c)Microcom 19Oct04  
**Algorithm:** Event Count  
**Data type:** Axle sensors - Paired (Class, Speed, Count)

**Profile:**

**Filter time:** 0:00 Tuesday, January 08, 2013 => 0:00 Friday, January 11, 2013  
**Name:** Factory default profile  
**Scheme:** Count events divided by two.  
**Units:** Non metric (ft, mi, ft/s, mph, lb, ton)  
**In profile:** Events = 10371

**Tuesday, January 08, 2013=3484, 15 minute drops**

0000	0100	0200	0300	0400	0500	0600	0700	0800	0900	1000	1100	1200	1300	1400	1500	1600	1700	1800	1900	2000	2100	2200	2300	
22	9	12	20	43	140	359	493	259	181	142	150	165	182	192	186	199	195	179	124	91	62	50	29	
7	2	4	2	6	19	63	97	71	39	40	39	53	45	47	42	47	53	45	34	31	16	19	8	2
4	3	2	5	13	27	70	144	72	44	38	38	33	44	43	48	46	40	55	38	25	17	14	5	8
5	4	5	8	15	46	115	154	71	48	33	39	38	39	55	46	62	44	46	26	19	14	10	10	2
6	0	1	5	9	48	111	98	45	50	31	34	41	54	47	50	44	58	33	26	16	15	7	6	3

AM Peak 0645 - 0745 (506), AM PHF=0.82 PM Peak 1545 - 1645 (205), PM PHF=0.83

**Wednesday, January 09, 2013=3458, 15 minute drops**

0000	0100	0200	0300	0400	0500	0600	0700	0800	0900	1000	1100	1200	1300	1400	1500	1600	1700	1800	1900	2000	2100	2200	2300	
15	13	10	25	42	137	362	498	282	154	164	156	151	177	178	185	204	207	187	110	70	67	39	25	
2	4	2	3	4	19	71	102	89	41	44	45	36	43	46	32	47	56	42	26	17	19	14	8	4
8	3	0	6	8	28	84	145	70	37	39	32	41	36	51	53	49	54	46	25	19	24	10	6	2
2	5	4	10	16	45	111	142	69	38	42	45	42	48	49	53	59	47	53	34	19	15	6	7	3
3	1	4	6	14	45	96	109	54	38	39	34	32	50	32	47	49	50	46	25	15	9	9	4	7

AM Peak 0700 - 0800 (498), AM PHF=0.86 PM Peak 1630 - 1730 (218), PM PHF=0.92

**Thursday, January 10, 2013=3429, 15 minute drops**

0000	0100	0200	0300	0400	0500	0600	0700	0800	0900	1000	1100	1200	1300	1400	1500	1600	1700	1800	1900	2000	2100	2200	2300	
16	9	13	22	48	139	334	522	273	153	125	138	139	168	194	198	208	188	184	104	92	78	53	31	
4	2	4	5	6	18	60	116	82	40	20	45	34	42	40	55	49	51	42	24	25	19	15	6	4
2	3	2	3	8	32	71	130	73	31	42	37	37	43	55	48	50	46	59	28	22	27	12	10	6
3	2	2	11	22	40	106	144	65	32	33	28	34	31	58	48	58	43	49	30	21	21	16	6	1
7	2	5	3	12	49	97	132	53	50	30	28	34	52	41	47	51	48	34	22	24	11	10	9	6

AM Peak 0700 - 0800 (522), AM PHF=0.91 PM Peak 1615 - 1715 (210), PM PHF=0.91



# Southern Traffic Services, Inc.

2911 Westfield Rd  
Gulf Breeze, FL 32563  
1-800-786-3374

*Traffic is our only business!*

US 41 @ Palm Ave  
Tampa, FL

File Name : 13015-5 US 41 @ Palm Ave  
Site Code : 13015-5  
Start Date : 1/9/2013  
Page No : 1

Groups Printed- Automobiles - Trucks - Buses

Start Time	US 41 Southbound				TWIN OAKS SHOPPING CENTER Westbound				US 41 Northbound				PALM AVE Eastbound				Int. Total
	Left	Thru	Right	U-Turns	Left	Thru	Right	U-Turns	Left	Thru	Right	U-Turns	Left	Thru	Right	U-Turns	
07:00 AM	4	141	0	0	1	0	1	0	2	386	0	0	2	0	2	0	539
07:15 AM	0	146	1	0	0	0	4	0	0	422	1	0	6	0	1	0	581
07:30 AM	5	167	1	0	0	0	3	0	0	480	2	0	1	0	2	0	661
07:45 AM	9	158	1	0	1	0	6	0	1	390	3	0	4	0	1	0	574
Total	18	612	3	0	2	0	14	0	3	1678	6	0	13	0	6	0	2355
08:00 AM	7	130	2	0	1	0	8	0	0	325	2	0	2	0	1	0	478
08:15 AM	6	143	2	0	0	0	5	0	2	311	0	0	2	0	2	0	473
08:30 AM	12	132	3	0	2	0	6	0	1	243	0	0	2	0	1	0	402
08:45 AM	2	141	1	0	3	0	6	0	1	206	0	0	2	1	1	0	364
Total	27	546	8	0	6	0	25	0	4	1085	2	0	8	1	5	0	1717
<b>**BREAK**</b>																	
04:00 PM	15	341	0	4	10	0	19	0	0	187	1	1	5	0	2	0	585
04:15 PM	19	333	2	1	16	0	18	0	0	170	4	0	3	1	0	0	567
04:30 PM	12	368	2	0	11	0	14	0	0	177	3	1	0	3	0	0	591
04:45 PM	13	357	2	2	9	1	13	0	0	189	3	2	1	0	0	0	592
Total	59	1399	6	7	46	1	64	0	0	723	11	4	9	4	2	0	2335
05:00 PM	6	380	4	0	8	0	18	0	0	236	3	0	7	0	0	0	662
05:15 PM	14	504	5	1	12	0	13	0	0	228	1	0	7	0	2	0	787
05:30 PM	7	392	6	0	11	1	12	0	2	212	2	0	4	2	1	0	652
05:45 PM	9	404	5	0	4	0	8	0	2	145	3	0	1	0	1	0	582
Total	36	1680	20	1	35	1	51	0	4	821	9	0	19	2	4	0	2683
Grand Total	140	4237	37	8	89	2	154	0	11	4307	28	4	49	7	17	0	9090
Apprch %	3.2	95.8	0.8	0.2	36.3	0.8	62.9	0	0.3	99	0.6	0.1	67.1	9.6	23.3	0	
Total %	1.5	46.6	0.4	0.1	1	0	1.7	0	0.1	47.4	0.3	0	0.5	0.1	0.2	0	
Automobiles	137	4088	37	8	89	2	154	0	9	4186	28	4	47	7	17	0	8813
% Automobiles	97.9	96.5	100	100	100	100	100	0	81.8	97.2	100	100	95.9	100	100	0	97
Trucks	3	131	0	0	0	0	0	0	2	109	0	0	1	0	0	0	246
% Trucks	2.1	3.1	0	0	0	0	0	0	18.2	2.5	0	0	2	0	0	0	2.7
Buses	0	18	0	0	0	0	0	0	0	12	0	0	1	0	0	0	31
% Buses	0	0.4	0	0	0	0	0	0	0	0.3	0	0	2	0	0	0	0.3



# Southern Traffic Services, Inc.

2911 Westfield Rd  
 Gulf Breeze, FL 32563  
 1-800-786-3374

*Traffic is our only business!*

US 41 @ Palm Ave  
 Tampa, FL

File Name : 13015-5 US 41 @ Palm Ave  
 Site Code : 13015-5  
 Start Date : 1/9/2013  
 Page No : 2

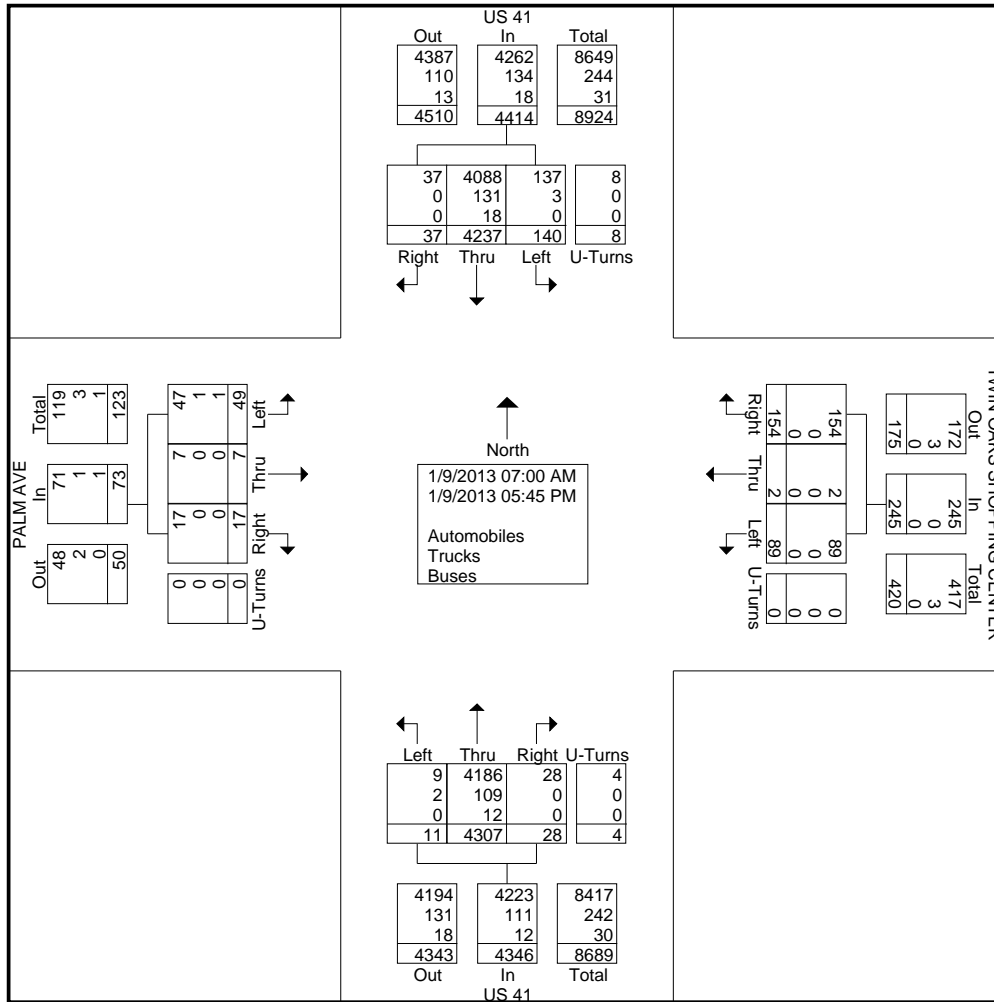



# Southern Traffic Services, Inc.

2911 Westfield Rd  
Gulf Breeze, FL 32563  
1-800-786-3374

*Traffic is our only business!*

US 41 @ Palm Ave  
Tampa, FL

File Name : 13015-5 US 41 @ Palm Ave  
Site Code : 13015-5  
Start Date : 1/9/2013  
Page No : 3

Start Time	US 41 Southbound					TWIN OAKS SHOPPING CENTER Westbound					US 41 Northbound					PALM AVE Eastbound					Int. Total
	Thru	Right	U-Turns	App. Total	Left	Thru	Right	U-Turns	App. Total	Left	Thru	Right	U-Turns	App. Total	Left	Thru	Right	U-Turns	App. Total		
Peak Hour Analysis From 07:00 AM to 11:45 AM - Peak 1 of 1																					
Peak Hour for Entire Intersection Begins at 07:00 AM																					
07:00 AM	4	141	0	0	145	1	0	1	0	2	2	386	0	0	388	2	0	2	0	4	539
07:15 AM	0	146	1	0	147	0	0	4	0	4	0	422	1	0	423	6	0	1	0	7	581
07:30 AM	5	167	1	0	173	0	0	3	0	3	0	480	2	0	482	1	0	2	0	3	661
07:45 AM	9	158	1	0	168	1	0	6	0	7	1	390	3	0	394	4	0	1	0	5	574
Total Volume	18	612	3	0	633	2	0	14	0	16	3	1678	6	0	1687	13	0	6	0	19	2355
% App. Total	2.8	96.7	0.5	0		12.5	0	87.5	0		0.2	99.5	0.4	0		68.4	0	31.6	0		
PHF	.500	.916	.750	.000	.915	.500	.000	.583	.000	.571	.375	.874	.500	.000	.875	.542	.000	.750	.000	.679	.891
Automobiles	17	553	3	0	573	2	0	14	0	16	3	1659	6	0	1668	13	0	6	0	19	2276
% Automobiles	94.4	90.4	100	0	90.5	100	0	100	0	100	100	98.9	100	0	98.9	100	0	100	0	100	96.6
Trucks	1	56	0	0	57	0	0	0	0	0	0	16	0	0	16	0	0	0	0	0	73
% Trucks	5.6	9.2	0	0	9.0	0	0	0	0	0	0	1.0	0	0	0.9	0	0	0	0	0	3.1
Buses	0	3	0	0	3	0	0	0	0	0	0	3	0	0	3	0	0	0	0	0	6
% Buses	0	0.5	0	0	0.5	0	0	0	0	0	0	0.2	0	0	0.2	0	0	0	0	0	0.3

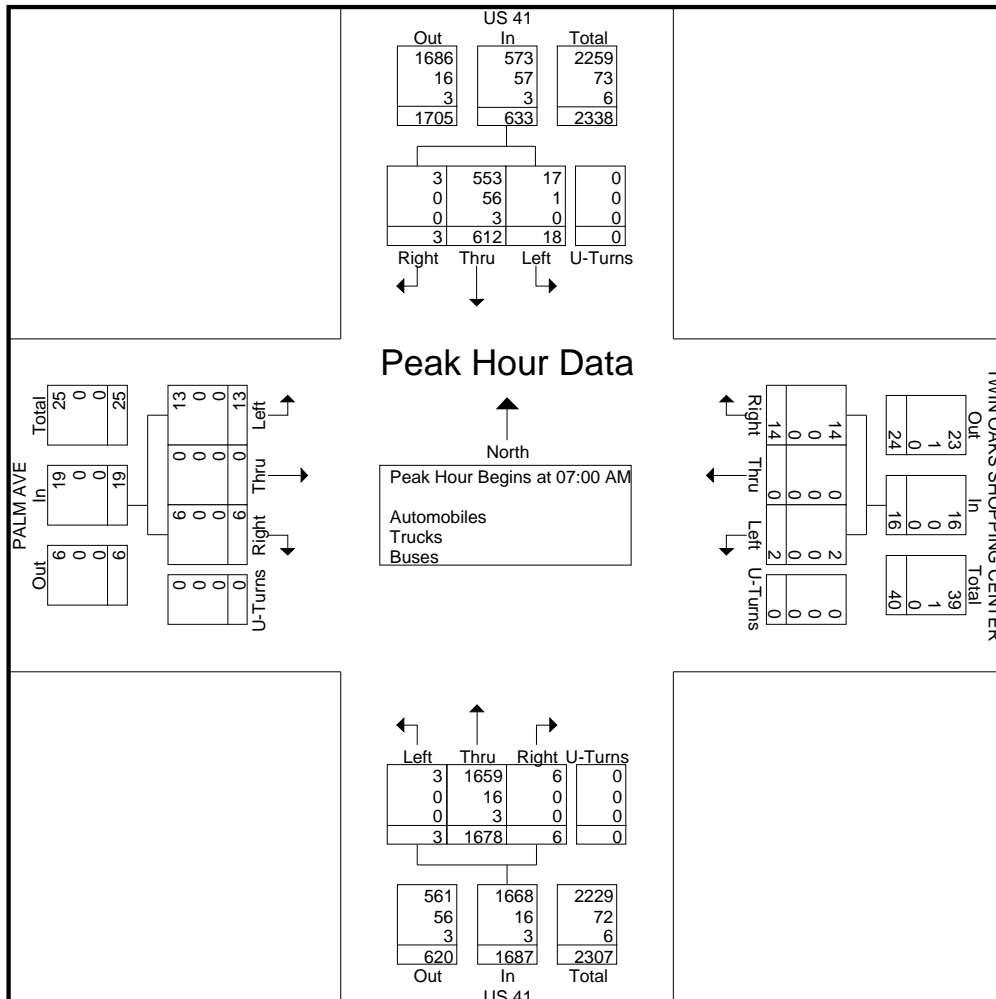



# Southern Traffic Services, Inc.

2911 Westfield Rd  
Gulf Breeze, FL 32563  
1-800-786-3374

*Traffic is our only business!*

US 41 @ Palm Ave  
Tampa, FL

File Name : 13015-5 US 41 @ Palm Ave  
Site Code : 13015-5  
Start Date : 1/9/2013  
Page No : 4

Start Time	US 41 Southbound					TWIN OAKS SHOPPING CENTER Westbound					US 41 Northbound					PALM AVE Eastbound					Int. Total
	Left	Thru	Right	U-Turns	App. Total	Left	Thru	Right	U-Turns	App. Total	Left	Thru	Right	U-Turns	App. Total	Left	Thru	Right	U-Turns	App. Total	
Peak Hour Analysis From 12:00 PM to 05:45 PM - Peak 1 of 1																					
Peak Hour for Entire Intersection Begins at 04:45 PM																					
04:45 PM	13	357	2	2	374	9	1	13	0	23	0	189	3	2	194	1	0	0	0	1	592
05:00 PM	6	380	4	0	390	8	0	18	0	26	0	236	3	0	239	7	0	0	0	7	662
05:15 PM	14	504	5	1	524	12	0	13	0	25	0	228	1	0	229	7	0	2	0	9	787
05:30 PM	7	392	6	0	405	11	1	12	0	24	2	212	2	0	216	4	2	1	0	7	652
Total Volume	40	1633	17	3	1693	40	2	56	0	98	2	865	9	2	878	19	2	3	0	24	2693
% App. Total	2.4	96.5	1	0.2		40.8	2	57.1	0		0.2	98.5	1	0.2		79.2	8.3	12.5	0		
PHF	.714	.810	.708	.375	.808	.833	.500	.778	.000	.942	.250	.916	.750	.250	.918	.679	.250	.375	.000	.667	.855
Automobiles	40	1610	17	3	1670	40	2	56	0	98	2	830	9	2	843	18	2	3	0	23	2634
% Automobiles	100	98.6	100	100	98.6	100	100	100	0	100	100	96.0	100	100	96.0	94.7	100	100	0	95.8	97.8
Trucks	0	18	0	0	18	0	0	0	0	0	0	30	0	0	30	0	0	0	0	0	48
% Trucks	0	1.1	0	0	1.1	0	0	0	0	0	0	3.5	0	0	3.4	0	0	0	0	0	1.8
Buses	0	5	0	0	5	0	0	0	0	0	0	5	0	0	5	1	0	0	0	1	11
% Buses	0	0.3	0	0	0.3	0	0	0	0	0	0	0.6	0	0	0.6	5.3	0	0	0	4.2	0.4

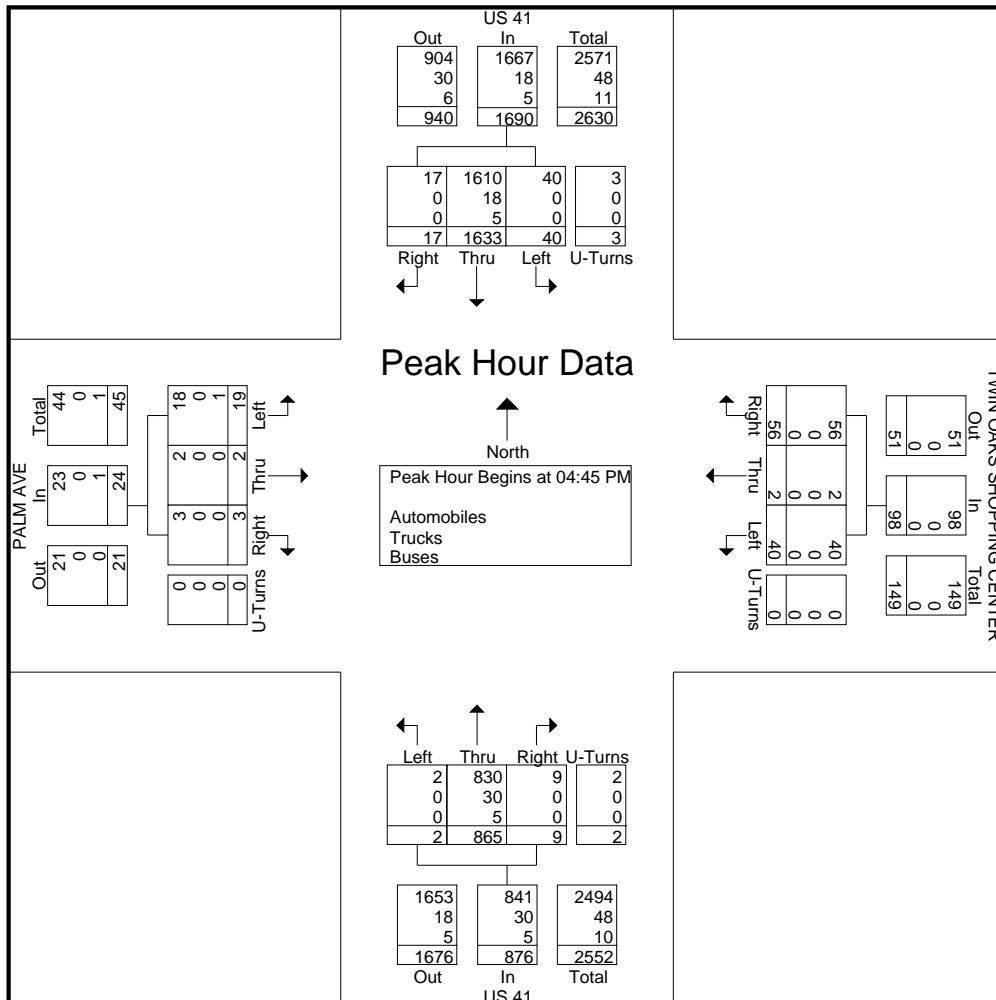



# Southern Traffic Services, Inc.

2911 Westfield Rd  
 Gulf Breeze, FL 32563  
 1-800-786-3374

*Traffic is our only business!*

US 41 @ Palm Ave  
 Tampa, FL

File Name : 13015-5 US 41 @ Palm Ave  
 Site Code : 13015-5  
 Start Date : 1/9/2013  
 Page No : 1

Groups Printed- Automobiles

Start Time	US 41 Southbound				TWIN OAKS SHOPPING CENTER Westbound				US 41 Northbound				PALM AVE Eastbound				Int. Total
	Left	Thru	Right	U-Turns	Left	Thru	Right	U-Turns	Left	Thru	Right	U-Turns	Left	Thru	Right	U-Turns	
07:00 AM	4	125	0	0	1	0	1	0	2	382	0	0	2	0	2	0	519
07:15 AM	0	129	1	0	0	0	4	0	0	415	1	0	6	0	1	0	557
07:30 AM	4	154	1	0	0	0	3	0	0	474	2	0	1	0	2	0	641
07:45 AM	9	145	1	0	1	0	6	0	1	388	3	0	4	0	1	0	559
<b>Total</b>	<b>17</b>	<b>553</b>	<b>3</b>	<b>0</b>	<b>2</b>	<b>0</b>	<b>14</b>	<b>0</b>	<b>3</b>	<b>1659</b>	<b>6</b>	<b>0</b>	<b>13</b>	<b>0</b>	<b>6</b>	<b>0</b>	<b>2276</b>
08:00 AM	6	123	2	0	1	0	8	0	0	318	2	0	2	0	1	0	463
08:15 AM	6	132	2	0	0	0	5	0	1	302	0	0	2	0	2	0	452
08:30 AM	12	114	3	0	2	0	6	0	1	235	0	0	2	0	1	0	376
08:45 AM	1	137	1	0	3	0	6	0	0	200	0	0	2	1	1	0	352
<b>Total</b>	<b>25</b>	<b>506</b>	<b>8</b>	<b>0</b>	<b>6</b>	<b>0</b>	<b>25</b>	<b>0</b>	<b>2</b>	<b>1055</b>	<b>2</b>	<b>0</b>	<b>8</b>	<b>1</b>	<b>5</b>	<b>0</b>	<b>1643</b>
<b>**BREAK**</b>																	
04:00 PM	15	331	0	4	10	0	19	0	0	176	1	1	4	0	2	0	563
04:15 PM	19	324	2	1	16	0	18	0	0	157	4	0	3	1	0	0	545
04:30 PM	12	362	2	0	11	0	14	0	0	167	3	1	0	3	0	0	575
04:45 PM	13	352	2	2	9	1	13	0	0	176	3	2	1	0	0	0	574
<b>Total</b>	<b>59</b>	<b>1369</b>	<b>6</b>	<b>7</b>	<b>46</b>	<b>1</b>	<b>64</b>	<b>0</b>	<b>0</b>	<b>676</b>	<b>11</b>	<b>4</b>	<b>8</b>	<b>4</b>	<b>2</b>	<b>0</b>	<b>2257</b>
05:00 PM	6	375	4	0	8	0	18	0	0	228	3	0	6	0	0	0	648
05:15 PM	14	495	5	1	12	0	13	0	0	223	1	0	7	0	2	0	773
05:30 PM	7	388	6	0	11	1	12	0	2	203	2	0	4	2	1	0	639
05:45 PM	9	402	5	0	4	0	8	0	2	142	3	0	1	0	1	0	577
<b>Total</b>	<b>36</b>	<b>1660</b>	<b>20</b>	<b>1</b>	<b>35</b>	<b>1</b>	<b>51</b>	<b>0</b>	<b>4</b>	<b>796</b>	<b>9</b>	<b>0</b>	<b>18</b>	<b>2</b>	<b>4</b>	<b>0</b>	<b>2637</b>
<b>Grand Total</b>	<b>137</b>	<b>4088</b>	<b>37</b>	<b>8</b>	<b>89</b>	<b>2</b>	<b>154</b>	<b>0</b>	<b>9</b>	<b>4186</b>	<b>28</b>	<b>4</b>	<b>47</b>	<b>7</b>	<b>17</b>	<b>0</b>	<b>8813</b>
<b>Apprch %</b>	<b>3.2</b>	<b>95.7</b>	<b>0.9</b>	<b>0.2</b>	<b>36.3</b>	<b>0.8</b>	<b>62.9</b>	<b>0</b>	<b>0.2</b>	<b>99</b>	<b>0.7</b>	<b>0.1</b>	<b>66.2</b>	<b>9.9</b>	<b>23.9</b>	<b>0</b>	
<b>Total %</b>	<b>1.6</b>	<b>46.4</b>	<b>0.4</b>	<b>0.1</b>	<b>1</b>	<b>0</b>	<b>1.7</b>	<b>0</b>	<b>0.1</b>	<b>47.5</b>	<b>0.3</b>	<b>0</b>	<b>0.5</b>	<b>0.1</b>	<b>0.2</b>	<b>0</b>	



# Southern Traffic Services, Inc.

2911 Westfield Rd  
Gulf Breeze, FL 32563  
1-800-786-3374

*Traffic is our only business!*

US 41 @ Palm Ave  
Tampa, FL

File Name : 13015-5 US 41 @ Palm Ave  
Site Code : 13015-5  
Start Date : 1/9/2013  
Page No : 2

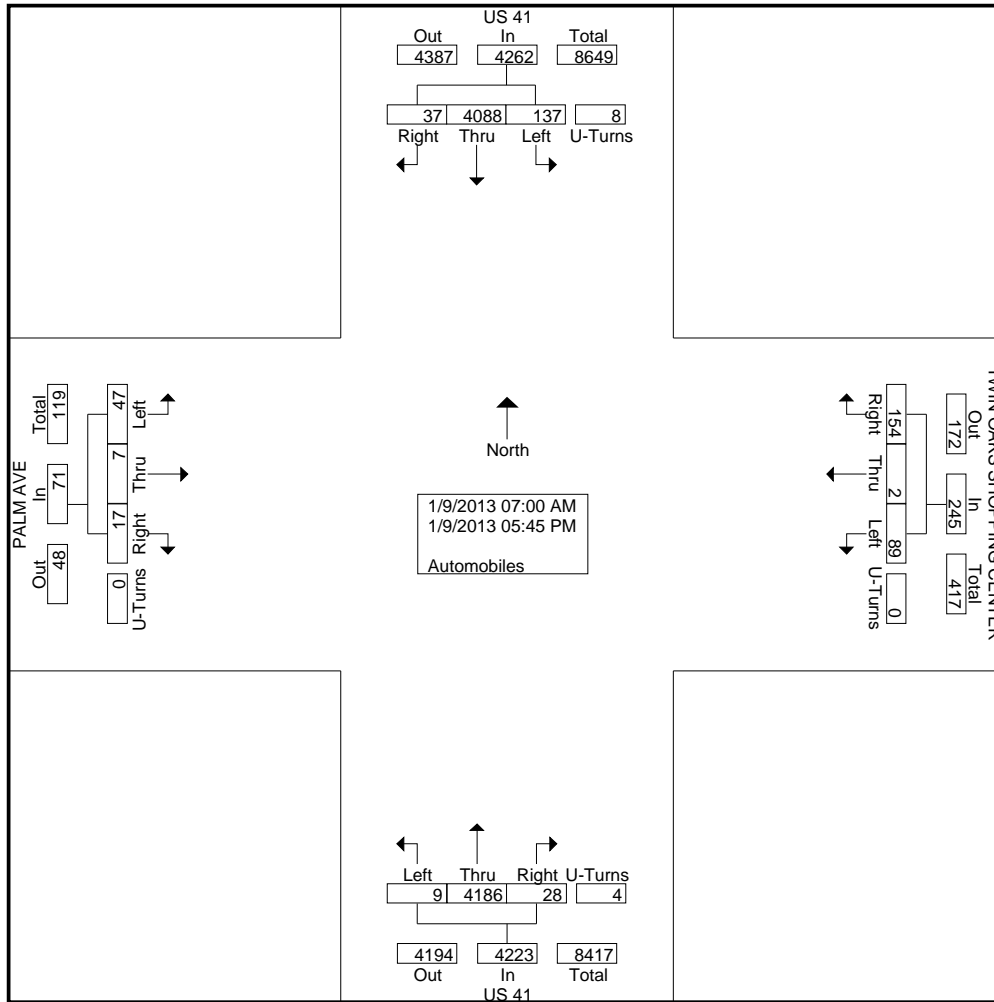



# Southern Traffic Services, Inc.

2911 Westfield Rd  
Gulf Breeze, FL 32563  
1-800-786-3374

*Traffic is our only business!*

US 41 @ Palm Ave  
Tampa, FL

File Name : 13015-5 US 41 @ Palm Ave  
Site Code : 13015-5  
Start Date : 1/9/2013  
Page No : 3

Start Time	US 41 Southbound					TWIN OAKS SHOPPING CENTER Westbound					US 41 Northbound					PALM AVE Eastbound					Int. Total
	Thru	Right	U-Turns	App. Total	Left	Thru	Right	U-Turns	App. Total	Left	Thru	Right	U-Turns	App. Total	Left	Thru	Right	U-Turns	App. Total		
Peak Hour Analysis From 07:00 AM to 11:45 AM - Peak 1 of 1																					
Peak Hour for Entire Intersection Begins at 07:00 AM																					
07:00 AM	4	125	0	0	129	1	0	1	0	2	2	382	0	0	384	2	0	2	0	4	519
07:15 AM	0	129	1	0	130	0	0	4	0	4	0	415	1	0	416	6	0	1	0	7	557
07:30 AM	4	154	1	0	159	0	0	3	0	3	0	474	2	0	476	1	0	2	0	3	641
07:45 AM	9	145	1	0	155	1	0	6	0	7	1	388	3	0	392	4	0	1	0	5	559
Total Volume	17	553	3	0	573	2	0	14	0	16	3	1659	6	0	1668	13	0	6	0	19	2276
% App. Total	3	96.5	0.5	0		12.5	0	87.5	0		0.2	99.5	0.4	0		68.4	0	31.6	0		
PHF	.472	.898	.750	.000	.901	.500	.000	.583	.000	.571	.375	.875	.500	.000	.876	.542	.000	.750	.000	.679	.888

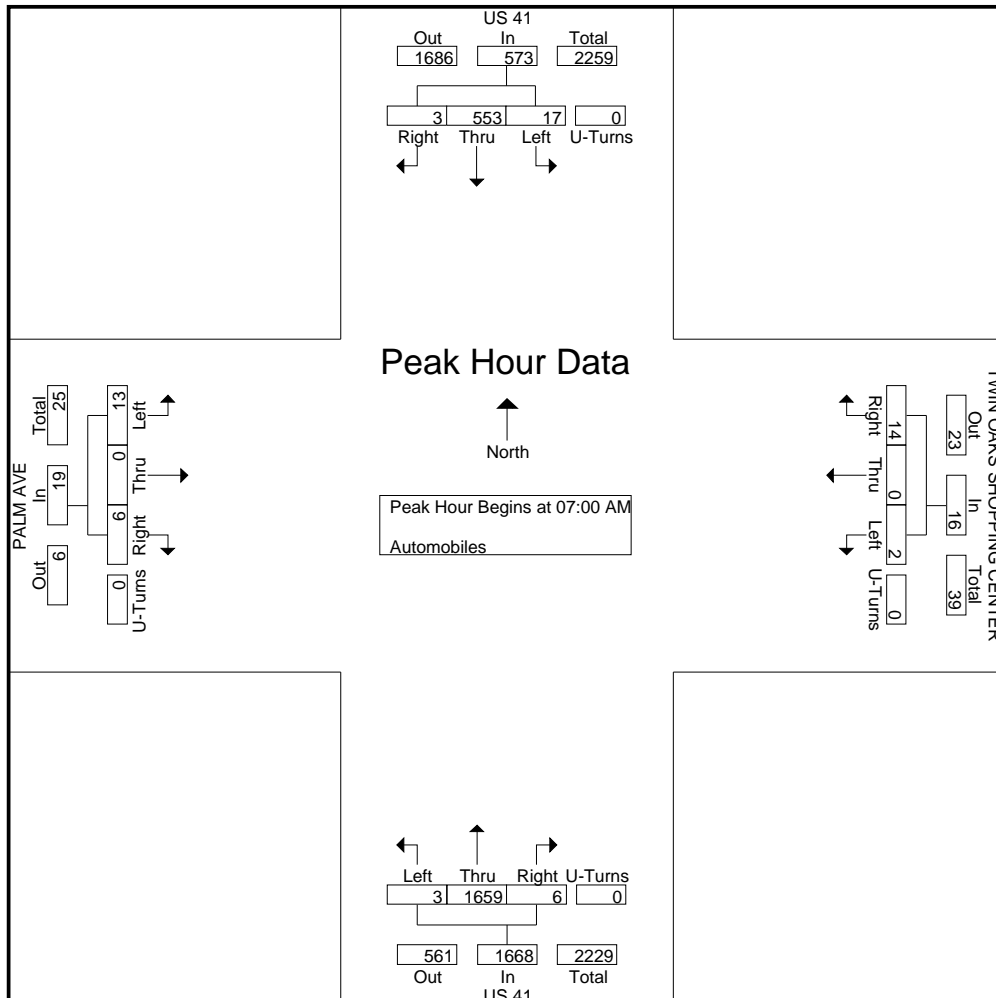





# Southern Traffic Services, Inc.

2911 Westfield Rd  
 Gulf Breeze, FL 32563  
 1-800-786-3374

*Traffic is our only business!*

US 41 @ Palm Ave  
 Tampa, FL

File Name : 13015-5 US 41 @ Palm Ave  
 Site Code : 13015-5  
 Start Date : 1/9/2013  
 Page No : 4

Start Time	US 41 Southbound					TWIN OAKS SHOPPING CENTER Westbound					US 41 Northbound					PALM AVE Eastbound					Int. Total
	Left	Thru	Right	U-Turns	App. Total	Left	Thru	Right	U-Turns	App. Total	Left	Thru	Right	U-Turns	App. Total	Left	Thru	Right	U-Turns	App. Total	
Peak Hour Analysis From 12:00 PM to 05:45 PM - Peak 1 of 1																					
Peak Hour for Entire Intersection Begins at 05:00 PM																					
05:00 PM	6	375	4	0	385	8	0	18	0	26	0	228	3	0	231	6	0	0	0	6	648
05:15 PM	14	495	5	1	515	12	0	13	0	25	0	223	1	0	224	7	0	2	0	9	773
05:30 PM	7	388	6	0	401	11	1	12	0	24	2	203	2	0	207	4	2	1	0	7	639
05:45 PM	9	402	5	0	416	4	0	8	0	12	2	142	3	0	147	1	0	1	0	2	577
Total Volume	36	1660	20	1	1717	35	1	51	0	87	4	796	9	0	809	18	2	4	0	24	2637
% App. Total	2.1	96.7	1.2	0.1		40.2	1.1	58.6	0		0.5	98.4	1.1	0		75	8.3	16.7	0		
PHF	.643	.838	.833	.250	.833	.729	.250	.708	.000	.837	.500	.873	.750	.000	.876	.643	.250	.500	.000	.667	.853

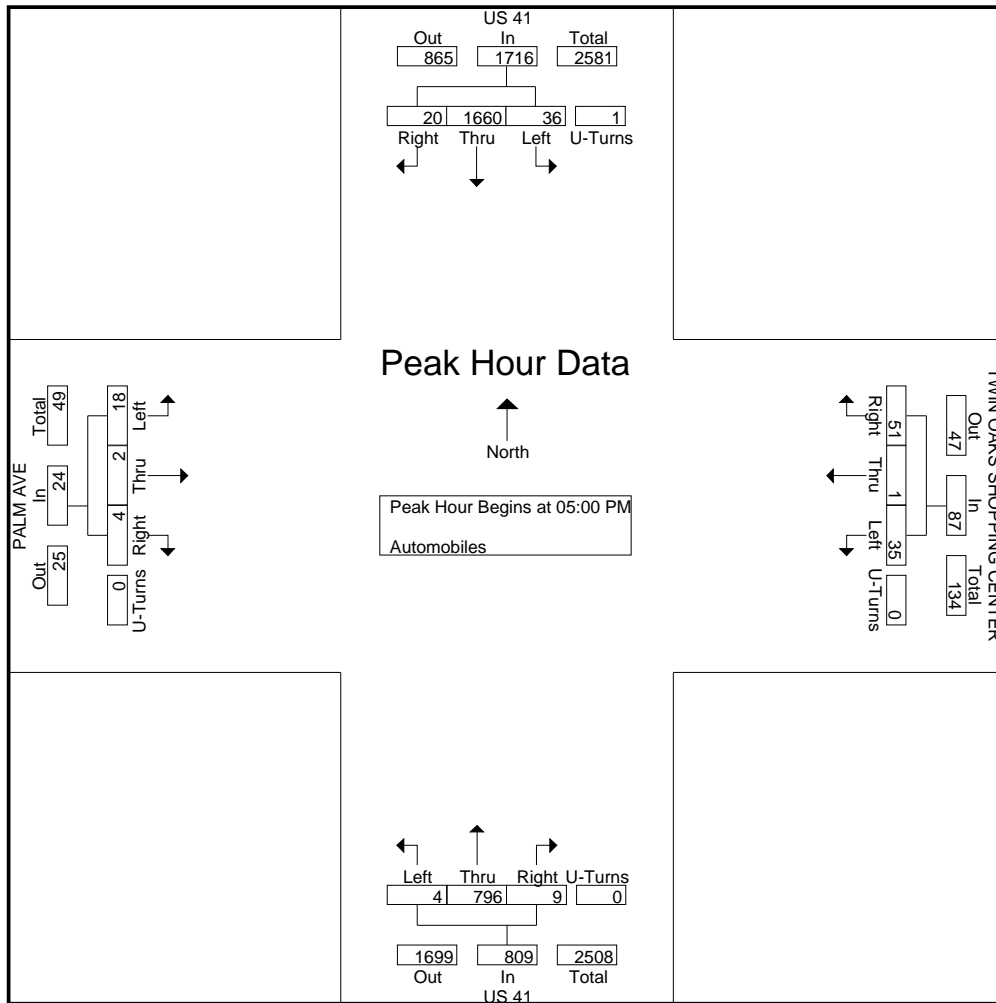



# Southern Traffic Services, Inc.

2911 Westfield Rd  
 Gulf Breeze, FL 32563  
 1-800-786-3374

*Traffic is our only business!*

US 41 @ Palm Ave  
 Tampa, FL

File Name : 13015-5 US 41 @ Palm Ave  
 Site Code : 13015-5  
 Start Date : 1/9/2013  
 Page No : 1

Groups Printed- Trucks - Buses

Start Time	US 41 Southbound				TWIN OAKS SHOPPING CENTER Westbound				US 41 Northbound				PALM AVE Eastbound				Int. Total	
	Left	Thru	Right	U-Turns	Left	Thru	Right	U-Turns	Left	Thru	Right	U-Turns	Left	Thru	Right	U-Turns		
07:00 AM	0	16	0	0	0	0	0	0	0	4	0	0	0	0	0	0	0	20
07:15 AM	0	17	0	0	0	0	0	0	0	7	0	0	0	0	0	0	0	24
07:30 AM	1	13	0	0	0	0	0	0	0	6	0	0	0	0	0	0	0	20
07:45 AM	0	13	0	0	0	0	0	0	0	2	0	0	0	0	0	0	0	15
Total	1	59	0	0	0	0	0	0	0	19	0	0	0	0	0	0	0	79
08:00 AM	1	7	0	0	0	0	0	0	0	7	0	0	0	0	0	0	0	15
08:15 AM	0	11	0	0	0	0	0	0	1	9	0	0	0	0	0	0	0	21
08:30 AM	0	18	0	0	0	0	0	0	0	8	0	0	0	0	0	0	0	26
08:45 AM	1	4	0	0	0	0	0	0	1	6	0	0	0	0	0	0	0	12
Total	2	40	0	0	0	0	0	0	2	30	0	0	0	0	0	0	0	74
<b>**BREAK**</b>																		
04:00 PM	0	10	0	0	0	0	0	0	0	11	0	0	0	1	0	0	0	22
04:15 PM	0	9	0	0	0	0	0	0	0	13	0	0	0	0	0	0	0	22
04:30 PM	0	6	0	0	0	0	0	0	0	10	0	0	0	0	0	0	0	16
04:45 PM	0	5	0	0	0	0	0	0	0	13	0	0	0	0	0	0	0	18
Total	0	30	0	0	0	0	0	0	0	47	0	0	0	1	0	0	0	78
05:00 PM	0	5	0	0	0	0	0	0	0	8	0	0	0	1	0	0	0	14
05:15 PM	0	9	0	0	0	0	0	0	0	5	0	0	0	0	0	0	0	14
05:30 PM	0	4	0	0	0	0	0	0	0	9	0	0	0	0	0	0	0	13
05:45 PM	0	2	0	0	0	0	0	0	0	3	0	0	0	0	0	0	0	5
Total	0	20	0	0	0	0	0	0	0	25	0	0	0	1	0	0	0	46
Grand Total	3	149	0	0	0	0	0	0	2	121	0	0	0	2	0	0	0	277
Apprch %	2	98	0	0	0	0	0	0	1.6	98.4	0	0	0	100	0	0	0	
Total %	1.1	53.8	0	0	0	0	0	0	0.7	43.7	0	0	0	0.7	0	0	0	
Trucks	3	131	0	0	0	0	0	0	2	109	0	0	0	1	0	0	0	246
% Trucks	100	87.9	0	0	0	0	0	0	100	90.1	0	0	0	50	0	0	0	88.8
Buses	0	18	0	0	0	0	0	0	0	12	0	0	0	1	0	0	0	31
% Buses	0	12.1	0	0	0	0	0	0	0	9.9	0	0	0	50	0	0	0	11.2



# Southern Traffic Services, Inc.

2911 Westfield Rd  
 Gulf Breeze, FL 32563  
 1-800-786-3374  
*Traffic is our only business!*

US 41 @ Palm Ave  
 Tampa, FL

File Name : 13015-5 US 41 @ Palm Ave  
 Site Code : 13015-5  
 Start Date : 1/9/2013  
 Page No : 2

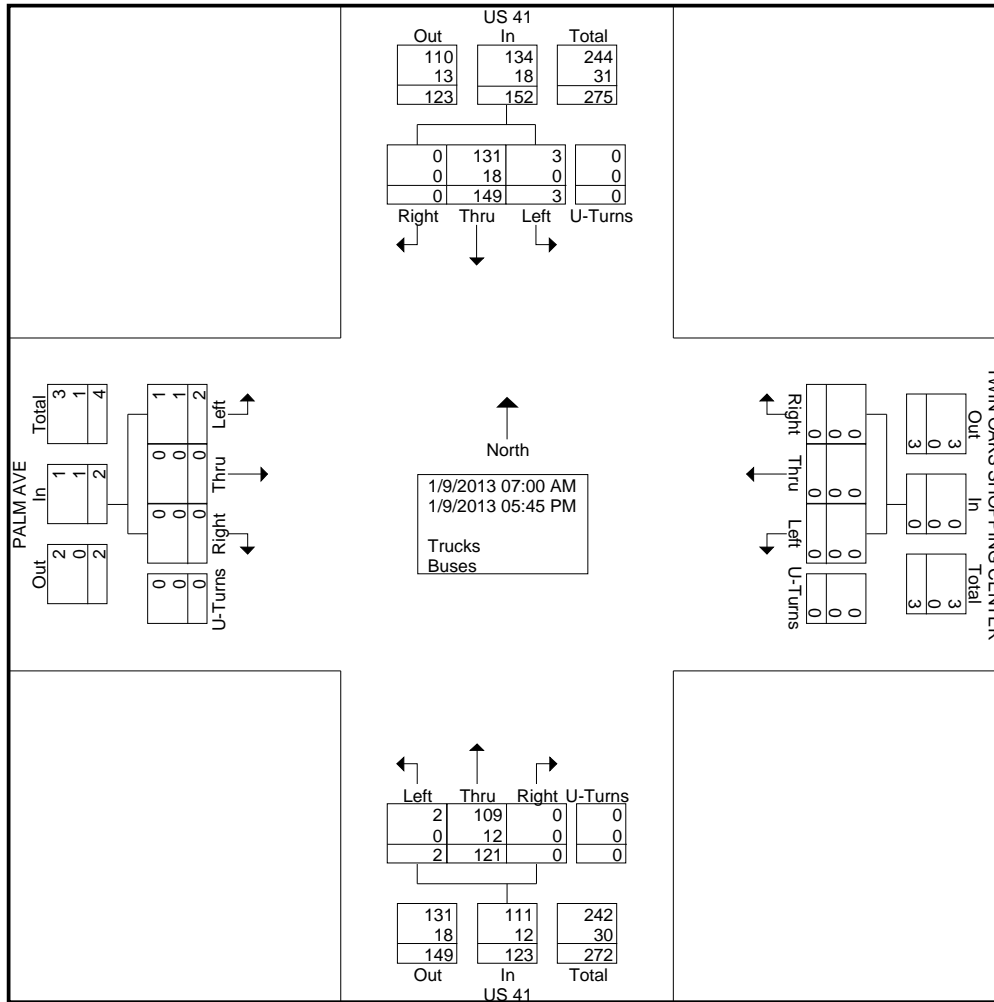



# Southern Traffic Services, Inc.

2911 Westfield Rd  
Gulf Breeze, FL 32563  
1-800-786-3374

*Traffic is our only business!*

US 41 @ Palm Ave  
Tampa, FL

File Name : 13015-5 US 41 @ Palm Ave  
Site Code : 13015-5  
Start Date : 1/9/2013  
Page No : 3

Start Time	US 41 Southbound					TWIN OAKS SHOPPING CENTER Westbound					US 41 Northbound					PALM AVE Eastbound					Int. Total
	Thru	Right	U-Turns	App. Total	Left	Thru	Right	U-Turns	App. Total	Left	Thru	Right	U-Turns	App. Total	Left	Thru	Right	U-Turns	App. Total		
Peak Hour Analysis From 07:00 AM to 11:45 AM - Peak 1 of 1																					
Peak Hour for Entire Intersection Begins at 07:00 AM																					
07:00 AM	0	16	0	0	16	0	0	0	0	0	0	4	0	0	4	0	0	0	0	0	20
07:15 AM	0	17	0	0	17	0	0	0	0	0	0	7	0	0	7	0	0	0	0	0	24
07:30 AM	1	13	0	0	14	0	0	0	0	0	0	6	0	0	6	0	0	0	0	0	20
07:45 AM	0	13	0	0	13	0	0	0	0	0	0	2	0	0	2	0	0	0	0	0	15
Total Volume	1	59	0	0	60	0	0	0	0	0	0	19	0	0	19	0	0	0	0	0	79
% App. Total	1.7	98.3	0	0		0	0	0	0	0	0	100	0	0		0	0	0	0	0	
PHF	.250	.868	.000	.000	.882	.000	.000	.000	.000	.000	.000	.679	.000	.000	.679	.000	.000	.000	.000	.000	.823

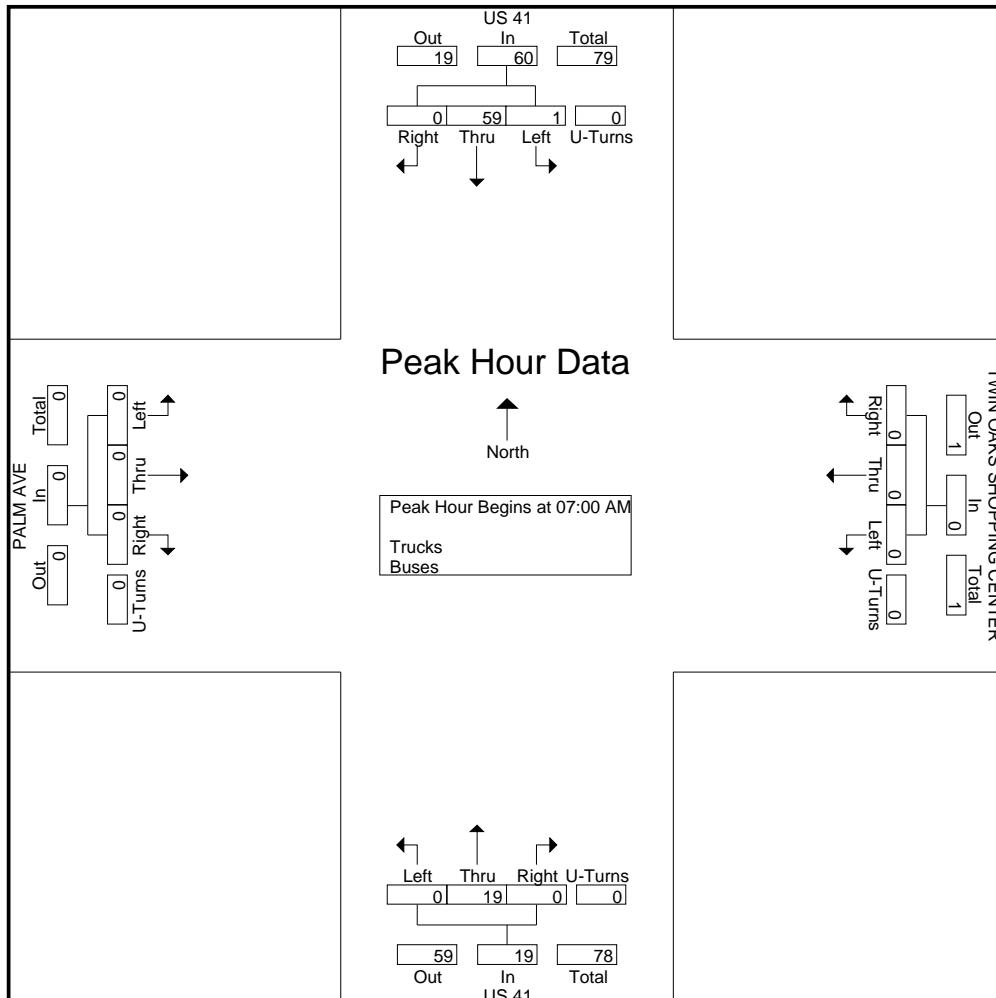



# Southern Traffic Services, Inc.

2911 Westfield Rd  
Gulf Breeze, FL 32563  
1-800-786-3374

*Traffic is our only business!*

US 41 @ Palm Ave  
Tampa, FL

File Name : 13015-5 US 41 @ Palm Ave  
Site Code : 13015-5  
Start Date : 1/9/2013  
Page No : 4

Start Time	US 41 Southbound					TWIN OAKS SHOPPING CENTER Westbound					US 41 Northbound					PALM AVE Eastbound					Int. Total
	Left	Thru	Right	U-Turns	App. Total	Left	Thru	Right	U-Turns	App. Total	Left	Thru	Right	U-Turns	App. Total	Left	Thru	Right	U-Turns	App. Total	
Peak Hour Analysis From 12:00 PM to 05:45 PM - Peak 1 of 1																					
Peak Hour for Entire Intersection Begins at 04:00 PM																					
04:00 PM	0	10	0	0	10	0	0	0	0	0	0	11	0	0	11	1	0	0	0	1	22
04:15 PM	0	9	0	0	9	0	0	0	0	0	0	13	0	0	13	0	0	0	0	0	22
04:30 PM	0	6	0	0	6	0	0	0	0	0	0	10	0	0	10	0	0	0	0	0	16
04:45 PM	0	5	0	0	5	0	0	0	0	0	0	13	0	0	13	0	0	0	0	0	18
Total Volume	0	30	0	0	30	0	0	0	0	0	0	47	0	0	47	1	0	0	0	1	78
% App. Total	0	100	0	0		0	0	0	0		0	100	0	0		100	0	0	0		
PHF	.000	.750	.000	.000	.750	.000	.000	.000	.000	.000	.000	.904	.000	.000	.904	.250	.000	.000	.000	.250	.886

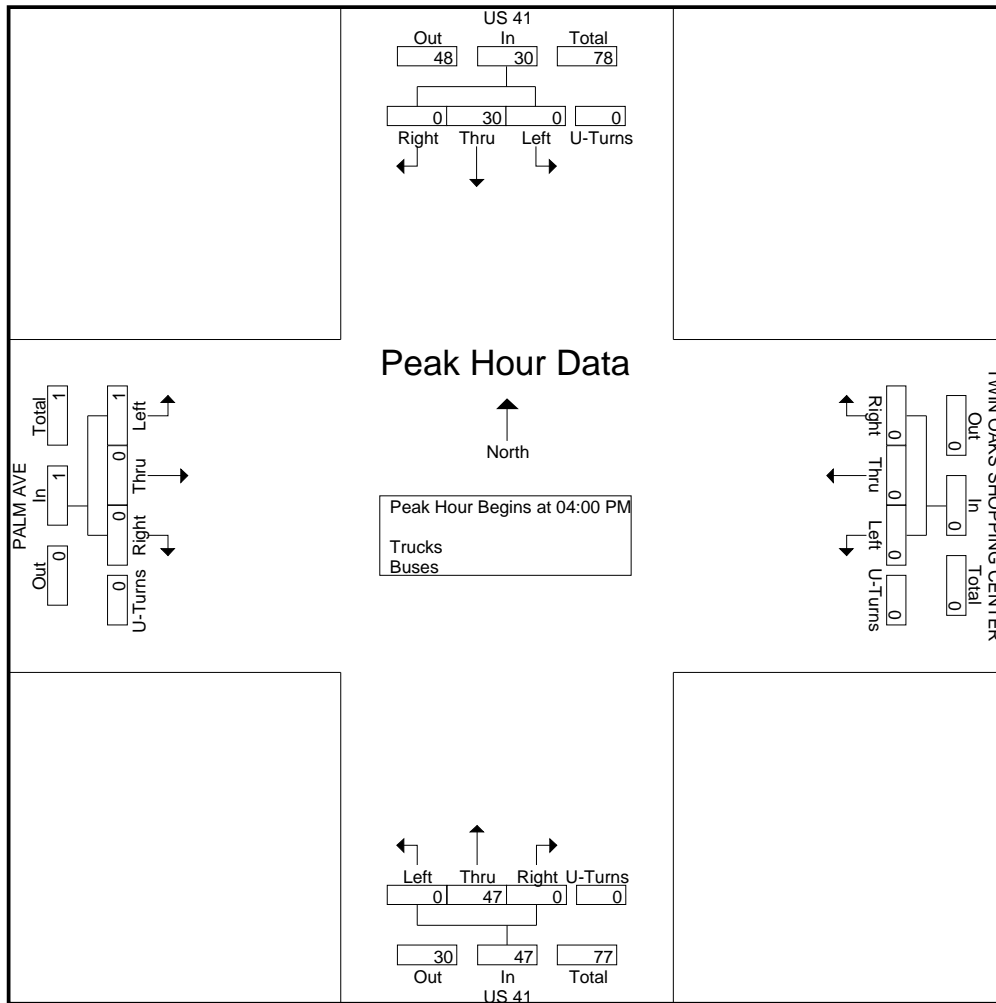



# Southern Traffic Services, Inc.

2911 Westfield Rd  
 Gulf Breeze, FL 32563  
 1-800-786-3374

*Traffic is our only business!*

US 41 @ Palm Ave  
 Tampa, FL

File Name : 13015-5 US 41 @ Palm Ave Peds  
 Site Code : 13015-5  
 Start Date : 1/9/2013  
 Page No : 1

Groups Printed- Peds

	US 41 Southbound	TWIN OAKS SHOPPING CENTER Westbound	US 41 Northbound	PALM AVE Eastbound	
Start Time	Peds	Peds	Peds	Peds	Int. Total
07:00 AM	1	0	0	2	3
07:15 AM	0	0	0	0	0
07:30 AM	2	0	0	2	4
07:45 AM	3	0	0	3	6
Total	6	0	0	7	13
08:00 AM	0	1	0	0	1
08:15 AM	0	8	0	2	10
08:30 AM	2	5	0	0	7
08:45 AM	3	2	0	3	8
Total	5	16	0	5	26
09:00 AM	0	0	0	0	0
09:15 AM	0	0	0	0	0
09:30 AM	0	0	0	0	0
09:45 AM	0	0	0	0	0
Total	0	0	0	0	0
10:00 AM	0	0	0	0	0
10:15 AM	0	0	0	0	0
10:30 AM	0	0	0	0	0
10:45 AM	0	0	0	0	0
Total	0	0	0	0	0
11:00 AM	0	0	0	0	0
11:15 AM	0	0	0	0	0
11:30 AM	0	0	0	0	0
11:45 AM	0	0	0	0	0
Total	0	0	0	0	0
12:00 PM	0	0	0	0	0
12:15 PM	0	0	0	0	0
12:30 PM	0	0	0	0	0
12:45 PM	0	0	0	0	0
Total	0	0	0	0	0
01:00 PM	0	0	0	0	0
01:15 PM	0	0	0	0	0
01:30 PM	0	0	0	0	0
01:45 PM	0	0	0	0	0
Total	0	0	0	0	0
02:00 PM	0	0	0	0	0
02:15 PM	0	0	0	0	0
02:30 PM	0	0	0	0	0
02:45 PM	0	0	0	0	0
Total	0	0	0	0	0
03:00 PM	0	0	0	0	0
03:15 PM	0	0	0	0	0
03:30 PM	0	0	0	0	0
03:45 PM	0	0	0	0	0
Total	0	0	0	0	0



# Southern Traffic Services, Inc.

2911 Westfield Rd  
 Gulf Breeze, FL 32563  
 1-800-786-3374

*Traffic is our only business!*

US 41 @ Palm Ave  
 Tampa, FL

File Name : 13015-5 US 41 @ Palm Ave Peds  
 Site Code : 13015-5  
 Start Date : 1/9/2013  
 Page No : 2

Groups Printed- Peds

	US 41 Southbound	TWIN OAKS SHOPPING CENTER Westbound	US 41 Northbound	PALM AVE Eastbound	Int. Total
Start Time	Peds	Peds	Peds	Peds	
04:00 PM	0	1	0	0	1
04:15 PM	0	0	0	0	0
04:30 PM	0	0	0	0	0
04:45 PM	0	0	0	0	0
Total	0	1	0	0	1
05:00 PM	0	0	0	0	0
05:15 PM	0	0	0	0	0
05:30 PM	0	0	0	0	0
05:45 PM	0	0	0	0	0
Total	0	0	0	0	0
Grand Total	11	17	0	12	40
Apprch %	100	100	0	100	
Total %	27.5	42.5	0	30	

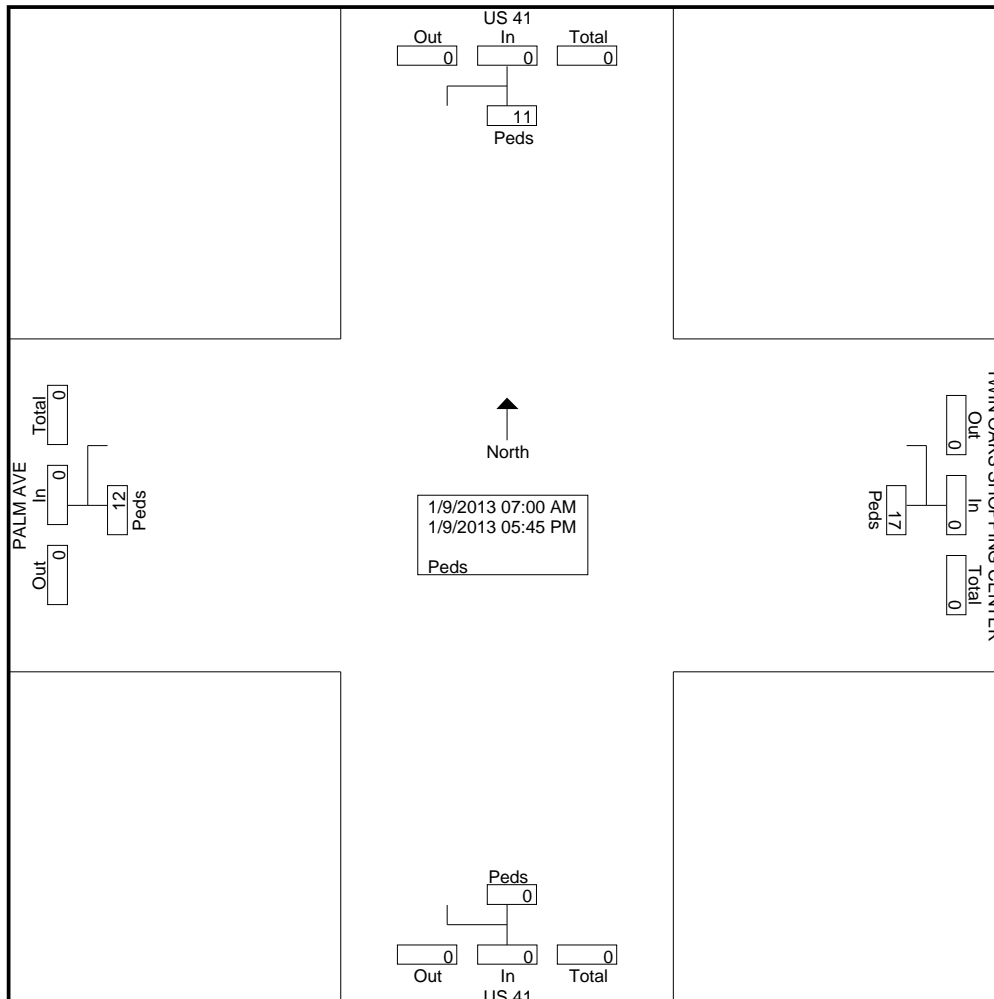

# Southern Traffic Services, Inc.

## Event Counts

**US 41 north of Palm Avenue**

**Northbound**

**Datasets:**

**Site:** [051] IC.3AA  
**Input A:** 7 - North bound A>B, South bound B>A. - Excluded from totals. (0)  
**Input B:** 0 - Unused or unknown. - Added to totals. (1)  
**Survey Duration:** 14:38 Monday, January 07, 2013 => 11:12 Friday, January 11, 2013  
**File:** G:\DATA\2013\Private\13015\marco\Jan -11-2013 DATA\UM051.eco (Plus)  
**Identifier:** M3432SEX MC56-L5 [MC55] (c)Microcom 19Oct04  
**Algorithm:** Event Count  
**Data type:** Axle sensors - Paired (Class, Speed, Count)

**Profile:**

**Filter time:** 0:00 Tuesday, January 08, 2013 => 0:00 Friday, January 11, 2013  
**Name:** Factory default profile  
**Scheme:** Count events divided by two.  
**Units:** Non metric (ft, mi, ft/s, mph, lb, ton)  
**In profile:** Events = 45076

**Tuesday, January 08, 2013=15071, 15 minute drops**

0000	0100	0200	0300	0400	0500	0600	0700	0800	0900	1000	1100	1200	1300	1400	1500	1600	1700	1800	1900	2000	2100	2200	2300	
58	41	27	80	176	597	1449	1813	1200	843	780	794	859	903	906	1004	876	895	609	387	277	234	145	118	
17	13	9	16	25	96	259	422	355	120	167	185	188	223	205	247	238	250	177	100	63	65	41	33	16
14	13	2	19	36	133	365	459	330	275	218	214	234	236	247	233	185	224	179	130	59	58	38	29	21
19	10	11	26	57	159	384	532	281	228	210	194	208	228	234	275	217	236	142	97	84	49	33	42	16
8	5	5	19	58	209	441	400	234	220	185	201	229	216	220	249	236	185	111	60	71	62	33	14	13

AM Peak 0645 - 0745 (1854), AM PHF=0.87 PM Peak 1500 - 1600 (1004), PM PHF=0.91

**Wednesday, January 09, 2013=15143, 15 minute drops**

0000	0100	0200	0300	0400	0500	0600	0700	0800	0900	1000	1100	1200	1300	1400	1500	1600	1700	1800	1900	2000	2100	2200	2300	
66	45	41	89	180	656	1400	1815	1233	904	827	765	814	857	864	934	866	924	658	379	283	263	176	104	
16	16	11	15	28	102	249	426	387	229	225	203	181	242	237	201	219	264	175	135	69	95	54	35	17
21	10	8	29	45	136	386	465	337	218	207	183	211	200	189	210	205	256	167	87	94	65	46	24	12
16	10	10	26	51	178	382	513	265	241	195	179	217	226	222	270	209	235	154	85	66	53	45	20	12
13	9	12	19	56	240	383	411	244	216	200	200	205	189	216	253	233	169	162	72	54	50	31	25	11

AM Peak 0700 - 0800 (1815), AM PHF=0.88 PM Peak 1645 - 1745 (988), PM PHF=0.94

**Thursday, January 10, 2013=14862, 15 minute drops**

0000	0100	0200	0300	0400	0500	0600	0700	0800	0900	1000	1100	1200	1300	1400	1500	1600	1700	1800	1900	2000	2100	2200	2300	
52	46	40	63	175	594	1360	1849	1187	827	773	819	779	835	895	961	868	826	664	379	339	257	173	101	
17	9	11	14	25	93	255	474	359	221	195	209	180	196	220	198	218	237	203	90	74	68	45	29	13
12	10	9	17	35	121	333	468	343	212	228	214	193	200	195	234	209	194	170	116	85	66	41	24	20
12	18	10	22	63	169	432	495	250	204	72	203	206	225	263	289	218	225	144	90	92	68	42	35	11
11	9	10	10	52	211	340	412	235	190	278	193	200	214	217	240	223	170	147	83	88	55	45	13	20

AM Peak 0700 - 0800 (1849), AM PHF=0.93 PM Peak 1515 - 1615 (981), PM PHF=0.85



# Southern Traffic Services, Inc.

## Event Counts

**US 41 north of Palm Avenue**

**Southbound**

**Datasets:**

**Site:** [051] IC.3AA  
**Input A:** 7 - North bound A>B, South bound B>A. - Added to totals. (1)  
**Input B:** 0 - Unused or unknown. - Excluded from totals. (0)  
**Survey Duration:** 14:38 Monday, January 07, 2013 => 11:12 Friday, January 11, 2013  
**File:** G:\DATA\2013\Private\13015\marco\Jan -11-2013 DATA\UM051.eco (Plus)  
**Identifier:** M3432SEX MC56-L5 [MC55] (c)Microcom 19Oct04  
**Algorithm:** Event Count  
**Data type:** Axle sensors - Paired (Class, Speed, Count)

**Profile:**

**Filter time:** 0:00 Tuesday, January 08, 2013 => 0:00 Friday, January 11, 2013  
**Name:** Factory default profile  
**Scheme:** Count events divided by two.  
**Units:** Non metric (ft, mi, ft/s, mph, lb, ton)  
**In profile:** Events = 44341

**Tuesday, January 08, 2013=14726, 15 minute drops**

0000	0100	0200	0300	0400	0500	0600	0700	0800	0900	1000	1100	1200	1300	1400	1500	1600	1700	1800	1900	2000	2100	2200	2300	
167	72	46	70	106	212	530	621	591	597	589	704	685	777	811	1225	1558	1888	1365	718	514	397	284	199	
52	17	7	15	18	28	118	145	149	137	130	148	184	190	200	213	380	441	418	202	134	99	99	52	27
71	20	12	12	28	37	130	161	160	145	152	185	181	135	235	272	363	546	410	164	160	109	73	54	38
25	16	16	25	25	65	139	143	157	165	158	185	141	289	183	378	398	454	277	157	121	81	65	52	16
19	19	11	18	35	82	143	172	125	150	149	186	179	163	193	362	417	447	260	195	99	108	47	41	20

AM Peak 1115 - 1215 (740), AM PHF=0.99 PM Peak 1700 - 1800 (1888), PM PHF=0.86

**Wednesday, January 09, 2013=14792, 15 minute drops**

0000	0100	0200	0300	0400	0500	0600	0700	0800	0900	1000	1100	1200	1300	1400	1500	1600	1700	1800	1900	2000	2100	2200	2300	
101	78	58	50	86	247	542	654	646	585	621	596	759	742	817	1193	1547	1877	1321	692	550	453	352	225	
27	25	14	10	15	27	108	160	159	144	143	151	215	211	193	257	387	446	430	208	151	123	102	55	37
38	20	19	16	17	35	128	148	159	150	169	171	163	169	211	267	396	545	367	107	140	109	92	43	33
16	20	17	14	22	83	160	174	172	123	146	163	204	190	216	318	385	468	261	235	139	120	86	76	28
20	13	8	10	32	102	146	172	156	168	163	111	177	172	197	351	379	418	263	142	120	101	72	51	32

AM Peak 1145 - 1245 (693), AM PHF=0.81 PM Peak 1700 - 1800 (1877), PM PHF=0.86

**Thursday, January 10, 2013=14823, 15 minute drops**

0000	0100	0200	0300	0400	0500	0600	0700	0800	0900	1000	1100	1200	1300	1400	1500	1600	1700	1800	1900	2000	2100	2200	2300	
130	88	64	46	90	214	553	645	519	603	580	679	748	759	908	1184	1556	1899	1304	752	558	411	310	223	
37	27	17	10	12	31	124	161	102	168	141	156	171	173	196	229	359	459	371	245	140	111	73	19	40
33	21	16	11	19	37	151	168	167	135	143	167	202	209	267	295	405	490	328	210	155	127	78	100	46
28	22	17	15	28	66	152	173	148	148	132	171	193	126	194	314	359	525	325	157	135	92	78	58	34
32	18	14	10	31	80	126	143	102	152	164	185	182	251	251	346	433	425	280	140	128	81	81	46	28

AM Peak 1145 - 1245 (751), AM PHF=0.93 PM Peak 1645 - 1745 (1907), PM PHF=0.91

# Southern Traffic Services, Inc.

## Event Counts

**US 41 south of Palm Avenue**

**Northbound**

**Datasets:**

**Site:** [052] !C8027  
**Input A:** 7 - North bound A>B, South bound B>A. - Excluded from totals. (0)  
**Input B:** 0 - Unused or unknown. - Added to totals. (1)  
**Survey Duration:** 14:38 Monday, January 07, 2013 => 11:16 Friday, January 11, 2013  
**File:** G:\DATA\2013\Private\13015\marco\Jan -11-2013 DATA\UM052.eco (Plus)  
**Identifier:** V435XGKX MC56-L5 [MC55] (c)Microcom 19Oct04  
**Algorithm:** Event Count  
**Data type:** Axle sensors - Paired (Class, Speed, Count)

**Profile:**

**Filter time:** 0:00 Tuesday, January 08, 2013 => 0:00 Friday, January 11, 2013  
**Name:** Factory default profile  
**Scheme:** Count events divided by two.  
**Units:** Non metric (ft, mi, ft/s, mph, lb, ton)  
**In profile:** Events = 40941

**Tuesday, January 08, 2013=13574, 15 minute drops**

0000	0100	0200	0300	0400	0500	0600	0700	0800	0900	1000	1100	1200	1300	1400	1500	1600	1700	1800	1900	2000	2100	2200	2300	
53	35	25	79	176	580	1398	1744	1132	756	663	682	719	771	781	858	757	807	532	331	249	203	136	107	
15	11	9	16	24	98	244	402	338	112	153	166	169	191	169	213	207	218	152	90	56	53	37	29	15
13	11	2	19	37	129	357	443	312	246	182	183	178	205	215	199	162	206	150	108	55	51	36	24	17
18	8	9	25	57	153	373	521	257	202	166	155	175	187	209	239	189	205	130	81	74	43	32	39	16
7	5	5	19	58	200	424	378	225	196	162	178	197	188	188	207	199	178	100	52	64	56	31	15	13

AM Peak 0645 - 0745 (1790), AM PHF=0.86 PM Peak 1500 - 1600 (858), PM PHF=0.90

**Wednesday, January 09, 2013=13747, 15 minute drops**

0000	0100	0200	0300	0400	0500	0600	0700	0800	0900	1000	1100	1200	1300	1400	1500	1600	1700	1800	1900	2000	2100	2200	2300	
61	39	40	84	174	628	1324	1696	1140	799	709	654	711	747	773	860	770	833	609	346	251	239	158	102	
15	11	11	16	23	100	237	397	366	212	198	175	160	218	205	195	191	239	164	121	62	82	52	34	14
17	12	9	24	43	130	355	429	309	192	168	150	184	172	184	185	186	221	151	75	83	62	41	23	12
16	10	8	25	50	172	369	492	250	200	169	163	183	186	196	267	191	222	144	79	51	47	37	20	10
13	6	12	19	58	226	363	378	215	195	174	166	184	171	188	213	202	151	150	71	55	48	28	25	10

AM Peak 0700 - 0800 (1696), AM PHF=0.86 PM Peak 1645 - 1745 (884), PM PHF=0.92

**Thursday, January 10, 2013=13620, 15 minute drops**

0000	0100	0200	0300	0400	0500	0600	0700	0800	0900	1000	1100	1200	1300	1400	1500	1600	1700	1800	1900	2000	2100	2200	2300	
46	45	37	63	166	579	1290	1750	1118	741	677	724	678	741	803	866	781	758	602	350	308	240	166	91	
14	9	8	14	22	95	240	439	337	197	168	185	168	173	195	182	196	199	187	89	70	59	45	24	14
12	9	9	16	35	114	310	447	317	188	206	192	169	183	187	213	184	193	149	109	86	64	40	23	18
10	18	10	21	60	162	410	471	245	190	55	182	171	197	228	259	197	200	132	78	76	62	39	33	10
10	9	10	12	49	208	330	393	219	166	248	165	170	188	193	212	204	166	134	74	76	55	42	11	19

AM Peak 0700 - 0800 (1750), AM PHF=0.93 PM Peak 1515 - 1615 (880), PM PHF=0.85

# Southern Traffic Services, Inc.

## Event Counts

**US 41 south of Palm Avenue**

**Southbound**

**Datasets:**

**Site:** [052] !C8027  
**Input A:** 7 - North bound A>B, South bound B>A. - Added to totals. (1)  
**Input B:** 0 - Unused or unknown. - Excluded from totals. (0)  
**Survey Duration:** 14:38 Monday, January 07, 2013 => 11:16 Friday, January 11, 2013  
**File:** G:\DATA\2013\Private\13015\marco\Jan -11-2013 DATA\UM052.eco (Plus)  
**Identifier:** V435XGKX MC56-L5 [MC55] (c)Microcom 19Oct04  
**Algorithm:** Event Count  
**Data type:** Axle sensors - Paired (Class, Speed, Count)

**Profile:**

**Filter time:** 0:00 Tuesday, January 08, 2013 => 0:00 Friday, January 11, 2013  
**Name:** Factory default profile  
**Scheme:** Count events divided by two.  
**Units:** Non metric (ft, mi, ft/s, mph, lb, ton)  
**In profile:** Events = 42344

**Tuesday, January 08, 2013=14055, 15 minute drops**

0000	0100	0200	0300	0400	0500	0600	0700	0800	0900	1000	1100	1200	1300	1400	1500	1600	1700	1800	1900	2000	2100	2200	2300	
169	67	47	69	106	208	542	609	578	565	552	650	673	723	760	1137	1497	1759	1288	676	528	379	282	191	
53	16	7	15	18	28	118	143	142	128	122	145	180	176	171	193	360	421	401	196	136	95	98	50	28
71	19	14	12	28	38	135	161	157	143	143	162	177	121	230	254	350	494	362	156	161	103	70	53	38
26	15	16	24	26	65	143	140	152	146	140	179	131	267	175	346	369	437	288	154	128	78	66	47	16
19	17	10	18	34	77	146	165	127	148	147	164	185	159	184	344	418	407	237	170	103	103	48	41	20

AM Peak 1130 - 1230 (700), AM PHF=0.97 PM Peak 1645 - 1745 (1770), PM PHF=0.90

**Wednesday, January 09, 2013=14139, 15 minute drops**

0000	0100	0200	0300	0400	0500	0600	0700	0800	0900	1000	1100	1200	1300	1400	1500	1600	1700	1800	1900	2000	2100	2200	2300	
102	77	57	48	80	246	551	658	621	560	614	577	697	697	782	1136	1455	1726	1238	664	541	448	339	225	
28	24	15	9	13	25	108	165	144	137	152	155	190	192	175	241	349	409	399	195	153	118	98	56	34
38	18	20	17	19	35	135	145	161	149	158	165	155	161	195	244	367	477	338	114	140	116	89	42	33
16	23	14	14	18	85	159	178	167	121	141	149	188	167	210	325	366	427	262	221	131	117	85	79	28
20	12	8	8	30	101	149	170	149	153	163	108	164	177	202	326	373	413	239	134	117	97	67	48	32

AM Peak 0700 - 0800 (658), AM PHF=0.92 PM Peak 1700 - 1800 (1726), PM PHF=0.90

**Thursday, January 10, 2013=14150, 15 minute drops**

0000	0100	0200	0300	0400	0500	0600	0700	0800	0900	1000	1100	1200	1300	1400	1500	1600	1700	1800	1900	2000	2100	2200	2300	
127	89	64	46	90	213	550	636	498	584	546	631	704	701	875	1117	1460	1775	1220	748	548	397	313	218	
34	27	16	10	12	30	112	165	98	173	128	150	159	163	180	219	344	424	346	245	143	106	73	17	39
33	22	14	10	18	38	161	166	167	124	135	162	191	187	252	272	348	443	307	206	151	120	85	99	46
28	22	20	16	30	68	157	167	139	144	128	155	182	120	188	302	360	500	305	161	130	91	79	55	33
32	18	14	10	30	77	120	138	94	143	155	164	172	231	255	324	408	408	262	136	124	80	76	47	24

AM Peak 1145 - 1245 (696), AM PHF=0.91 PM Peak 1645 - 1745 (1775), PM PHF=0.89

# Southern Traffic Services, Inc.

## Event Counts

**Palm Avenue west of US 41**

**Eastbound**

**Datasets:**

**Site:** [054] !4284  
**Input A:** 8 - East bound A>B, West bound B>A. - Excluded from totals. (0)  
**Input B:** 0 - Unused or unknown. - Added to totals. (1)  
**Survey Duration:** 14:37 Monday, January 07, 2013 => 11:16 Friday, January 11, 2013  
**File:** G:\DATA\2013\Private\13015\marco\Jan -11-2013 DATA\UM054.eco (Base)  
**Identifier:** P233PV6G MC56-L4 [MC55] (c)Microcom 19Sep03  
**Algorithm:** Event Count  
**Data type:** Axle sensors - Paired (Class, Speed, Count)

**Profile:**

**Filter time:** 0:00 Tuesday, January 08, 2013 => 0:00 Friday, January 11, 2013  
**Name:** Factory default profile  
**Scheme:** Count events divided by two.  
**Units:** Non metric (ft, mi, ft/s, mph, lb, ton)  
**In profile:** Events = 864

**Tuesday, January 08, 2013=307, 15 minute drops**

0000	0100	0200	0300	0400	0500	0600	0700	0800	0900	1000	1100	1200	1300	1400	1500	1600	1700	1800	1900	2000	2100	2200	2300	
3	0	0	0	0	7	14	19	14	15	7	10	20	17	15	17	35	31	19	26	17	10	8	3	
1	0	0	0	0	2	3	9	5	3	2	0	4	1	4	1	11	12	6	13	5	7	1	0	0
1	0	0	0	0	2	4	3	5	5	2	2	2	7	7	4	6	3	5	4	1	2	4	1	0
1	0	0	0	0	0	4	5	2	3	2	2	8	7	1	1	6	6	2	5	7	0	0	1	0
0	0	0	0	0	3	3	2	2	4	1	6	6	2	3	11	12	10	6	4	4	1	3	1	0

AM Peak 0615 - 0715 (20), AM PHF=0.56 PM Peak 1615 - 1715 (36), PM PHF=0.75

**Wednesday, January 09, 2013=288, 15 minute drops**

0000	0100	0200	0300	0400	0500	0600	0700	0800	0900	1000	1100	1200	1300	1400	1500	1600	1700	1800	1900	2000	2100	2200	2300	
0	0	0	2	0	5	19	21	15	12	10	16	16	15	11	32	19	30	19	15	19	7	3	2	
0	0	0	0	0	0	5	8	3	6	0	5	5	5	2	4	10	7	2	4	2	5	1	2	1
0	0	0	0	0	2	7	4	6	2	2	3	4	5	3	12	5	8	4	5	8	1	1	0	0
0	0	0	0	0	0	3	4	2	3	4	5	6	3	5	5	3	9	10	5	7	1	0	0	1
0	0	0	2	0	3	4	5	4	1	4	3	1	2	1	11	1	6	3	1	2	0	1	0	0

AM Peak 0615 - 0715 (22), AM PHF=0.69 PM Peak 1515 - 1615 (38), PM PHF=0.79

**Thursday, January 10, 2013=269, 15 minute drops**

0000	0100	0200	0300	0400	0500	0600	0700	0800	0900	1000	1100	1200	1300	1400	1500	1600	1700	1800	1900	2000	2100	2200	2300	
2	2	0	1	3	6	20	20	15	7	10	11	19	12	17	13	21	26	14	15	15	10	5	5	
1	1	0	0	1	0	4	6	3	3	1	3	3	5	4	2	7	10	5	3	4	2	1	0	0
0	1	0	1	2	3	7	6	5	3	3	2	5	5	6	3	7	8	2	7	2	3	2	2	0
1	0	0	0	0	1	2	3	2	0	2	2	6	1	3	4	2	2	3	4	4	4	1	3	0
0	0	0	0	0	2	7	5	5	1	4	4	5	1	4	4	5	6	4	1	5	1	1	0	0

AM Peak 0615 - 0715 (22), AM PHF=0.79 PM Peak 1700 - 1800 (26), PM PHF=0.65

# Southern Traffic Services, Inc.

## Event Counts

**Palm Avenue west of US 41**

**Westbound**

**Datasets:**

**Site:** [054] !4284  
**Input A:** 8 - East bound A>B, West bound B>A. - Added to totals. (1)  
**Input B:** 0 - Unused or unknown. - Subtracted from totals. (-1)  
**Survey Duration:** 14:37 Monday, January 07, 2013 => 11:16 Friday, January 11, 2013  
**File:** G:\DATA\2013\Private\13015\marco\Jan -11-2013 DATA\UM054.eco (Base)  
**Identifier:** P233PV6G MC56-L4 [MC55] (c)Microcom 19Sep03  
**Algorithm:** Event Count  
**Data type:** Axle sensors - Paired (Class, Speed, Count)

**Profile:**

**Filter time:** 0:00 Tuesday, January 08, 2013 => 0:00 Friday, January 11, 2013  
**Name:** Factory default profile  
**Scheme:** Count events divided by two.  
**Units:** Non metric (ft, mi, ft/s, mph, lb, ton)  
**In profile:** Events = 813

**Tuesday, January 08, 2013=233, 15 minute drops**

0000	0100	0200	0300	0400	0500	0600	0700	0800	0900	1000	1100	1200	1300	1400	1500	1600	1700	1800	1900	2000	2100	2200	2300
2	0	2	0	0	1	21	7	9	9	4	11	16	15	14	12	7	26	26	18	14	10	6	3
0	0	0	0	0	0	3	3	3	0	1	0	3	9	3	2	3	6	10	4	6	7	1	2
2	0	0	0	0	0	10	1	3	5	2	2	4	2	5	5	2	7	5	6	1	1	3	0
0	0	0	0	0	0	4	3	3	1	1	3	6	2	0	1	0	7	5	2	5	2	2	1
0	0	2	0	0	1	4	0	0	3	0	6	3	2	6	4	2	6	6	6	2	0	0	0

AM Peak 0600 - 0700 (21), AM PHF=0.53 PM Peak 1715 - 1815 (30), PM PHF=0.75

**Wednesday, January 09, 2013=249, 15 minute drops**

0000	0100	0200	0300	0400	0500	0600	0700	0800	0900	1000	1100	1200	1300	1400	1500	1600	1700	1800	1900	2000	2100	2200	2300
0	0	0	1	0	3	17	7	13	8	9	15	14	17	19	17	7	30	22	21	17	3	5	4
0	0	0	0	0	1	6	2	2	3	0	5	8	6	4	0	0	4	1	5	5	1	4	2
0	0	0	0	0	1	6	2	5	0	0	2	0	5	9	10	3	8	5	2	6	0	0	0
0	0	0	0	0	0	1	1	4	3	5	2	3	3	5	2	1	10	12	5	5	1	0	0
0	0	0	1	0	1	4	2	2	2	4	6	3	3	1	5	3	8	4	9	1	1	1	2

AM Peak 1115 - 1215 (18), AM PHF=0.56 PM Peak 1815 - 1915 (26), PM PHF=0.54

**Thursday, January 10, 2013=331, 15 minute drops**

0000	0100	0200	0300	0400	0500	0600	0700	0800	0900	1000	1100	1200	1300	1400	1500	1600	1700	1800	1900	2000	2100	2200	2300
1	1	1	1	2	3	26	13	4	2	12	16	39	21	23	19	26	25	26	17	26	15	6	6
0	1	0	0	0	0	4	3	1	2	1	6	9	5	13	7	8	5	8	3	9	1	1	1
0	0	1	1	2	0	9	6	2	0	8	3	0	6	3	7	7	10	4	9	5	6	2	2
1	0	0	0	0	0	4	1	1	0	2	5	24	8	5	3	1	6	5	1	4	5	1	3
0	0	0	0	0	3	9	3	0	0	1	2	6	2	2	2	10	4	9	4	8	3	2	0

AM Peak 1145 - 1245 (35), AM PHF=0.36 PM Peak 1230 - 1330 (41), PM PHF=0.43



# Southern Traffic Services, Inc.

2911 Westfield Rd  
Gulf Breeze, FL 32563  
1-800-786-3374

*Traffic is our only business!*

US 41 @ Nundy Ave  
Tampa, FL

File Name : 13015-6 US 41 @ Nundy Ave  
Site Code : 13015-6  
Start Date : 1/9/2013  
Page No : 1

Groups Printed- Automobiles - Trucks - Buses

Start Time	US 41 Southbound				NUNDY AVE Westbound				US 41 Northbound				NUNDY AVE Eastbound				Int. Total
	Left	Thru	Right	U-Turns	Left	Thru	Right	U-Turns	Left	Thru	Right	U-Turns	Left	Thru	Right	U-Turns	
07:00 AM	4	150	0	0	8	0	7	0	2	435	7	1	1	1	2	0	618
07:15 AM	4	136	0	0	4	0	11	0	3	405	2	2	0	0	1	0	568
07:30 AM	7	152	1	0	4	0	5	0	2	484	4	0	0	1	1	0	661
07:45 AM	2	147	1	0	3	0	6	0	1	379	5	0	0	0	1	0	545
Total	17	585	2	0	19	0	29	0	8	1703	18	3	1	2	5	0	2392
08:00 AM	5	94	0	0	2	0	9	0	5	334	5	1	0	0	0	0	455
08:15 AM	4	166	2	0	2	0	6	0	4	299	6	0	0	0	2	0	491
08:30 AM	6	150	0	0	3	0	3	0	1	250	4	1	3	0	0	0	421
08:45 AM	5	99	0	0	4	0	4	0	2	222	3	0	0	0	0	0	339
Total	20	509	2	0	11	0	22	0	12	1105	18	2	3	0	2	0	1706
<b>**BREAK**</b>																	
04:00 PM	9	323	1	0	15	0	6	0	1	181	9	0	1	0	0	0	546
04:15 PM	11	333	3	0	16	0	9	0	2	180	13	0	0	0	1	0	568
04:30 PM	15	370	4	0	13	0	5	0	0	177	16	0	2	0	0	0	602
04:45 PM	12	370	0	0	10	1	5	0	4	207	9	0	0	0	2	0	620
Total	47	1396	8	0	54	1	25	0	7	745	47	0	3	0	3	0	2336
05:00 PM	13	416	5	0	12	0	6	0	0	206	10	0	0	0	1	0	669
05:15 PM	9	482	1	0	10	1	8	0	3	177	9	0	4	0	2	0	706
05:30 PM	13	394	1	0	15	0	6	0	2	182	17	0	0	0	8	0	638
05:45 PM	11	409	1	0	8	0	6	0	3	138	16	0	3	1	1	0	597
Total	46	1701	8	0	45	1	26	0	8	703	52	0	7	1	12	0	2610
Grand Total	130	4191	20	0	129	2	102	0	35	4256	135	5	14	3	22	0	9044
Apprch %	3	96.5	0.5	0	55.4	0.9	43.8	0	0.8	96.1	3	0.1	35.9	7.7	56.4	0	
Total %	1.4	46.3	0.2	0	1.4	0	1.1	0	0.4	47.1	1.5	0.1	0.2	0	0.2	0	
Automobiles	118	4010	20	0	126	2	92	0	32	4098	133	5	13	3	22	0	8674
% Automobiles	90.8	95.7	100	0	97.7	100	90.2	0	91.4	96.3	98.5	100	92.9	100	100	0	95.9
Trucks	8	161	0	0	3	0	6	0	3	147	1	0	1	0	0	0	330
% Trucks	6.2	3.8	0	0	2.3	0	5.9	0	8.6	3.5	0.7	0	7.1	0	0	0	3.6
Buses	4	20	0	0	0	0	4	0	0	11	1	0	0	0	0	0	40
% Buses	3.1	0.5	0	0	0	0	3.9	0	0	0.3	0.7	0	0	0	0	0	0.4



# Southern Traffic Services, Inc.

2911 Westfield Rd  
 Gulf Breeze, FL 32563  
 1-800-786-3374

*Traffic is our only business!*

US 41 @ Nundy Ave  
 Tampa, FL

File Name : 13015-6 US 41 @ Nundy Ave  
 Site Code : 13015-6  
 Start Date : 1/9/2013  
 Page No : 2

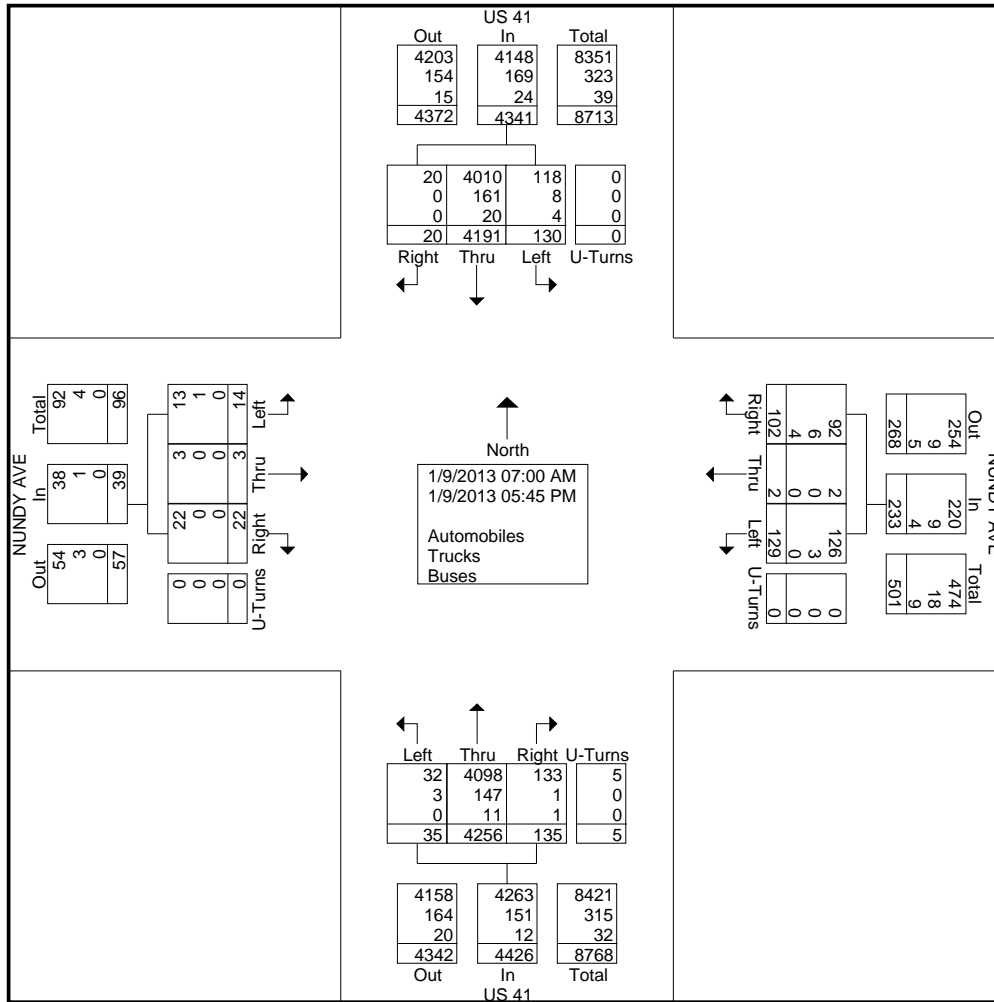



# Southern Traffic Services, Inc.

2911 Westfield Rd  
Gulf Breeze, FL 32563  
1-800-786-3374

*Traffic is our only business!*

US 41 @ Nundy Ave  
Tampa, FL

File Name : 13015-6 US 41 @ Nundy Ave  
Site Code : 13015-6  
Start Date : 1/9/2013  
Page No : 3

Start Time	US 41 Southbound				NUNDY AVE Westbound				US 41 Northbound				NUNDY AVE Eastbound				Int. Total				
	Thru	Right	U-Turns	App. Total	Left	Thru	Right	U-Turns	App. Total	Left	Thru	Right	U-Turns	App. Total	Left	Thru		Right	U-Turns	App. Total	
Peak Hour Analysis From 07:00 AM to 11:45 AM - Peak 1 of 1																					
Peak Hour for Entire Intersection Begins at 07:00 AM																					
07:00 AM	4	150	0	0	154	8	0	7	0	15	2	435	7	1	445	1	1	2	0	4	618
07:15 AM	4	136	0	0	140	4	0	11	0	15	3	405	2	2	412	0	0	1	0	1	568
07:30 AM	7	152	1	0	160	4	0	5	0	9	2	484	4	0	490	0	1	1	0	2	661
07:45 AM	2	147	1	0	150	3	0	6	0	9	1	379	5	0	385	0	0	1	0	1	545
Total Volume	17	585	2	0	604	19	0	29	0	48	8	1703	18	3	1732	1	2	5	0	8	2392
% App. Total	2.8	96.9	0.3	0		39.6	0	60.4	0		0.5	98.3	1	0.2		12.5	25	62.5	0		
PHF	.607	.962	.500	.000	.944	.594	.000	.659	.000	.800	.667	.880	.643	.375	.884	.250	.500	.625	.000	.500	.905
Automobiles	13	523	2	0	538	17	0	26	0	43	7	1667	18	3	1695	1	2	5	0	8	2284
% Automobiles	76.5	89.4	100	0	89.1	89.5	0	89.7	0	89.6	87.5	97.9	100	100	97.9	100	100	100	0	100	95.5
Trucks	2	58	0	0	60	2	0	2	0	4	1	32	0	0	33	0	0	0	0	0	97
% Trucks	11.8	9.9	0	0	9.9	10.5	0	6.9	0	8.3	12.5	1.9	0	0	1.9	0	0	0	0	0	4.1
Buses	2	4	0	0	6	0	0	1	0	1	0	4	0	0	4	0	0	0	0	0	11
% Buses	11.8	0.7	0	0	1.0	0	0	3.4	0	2.1	0	0.2	0	0	0.2	0	0	0	0	0	0.5

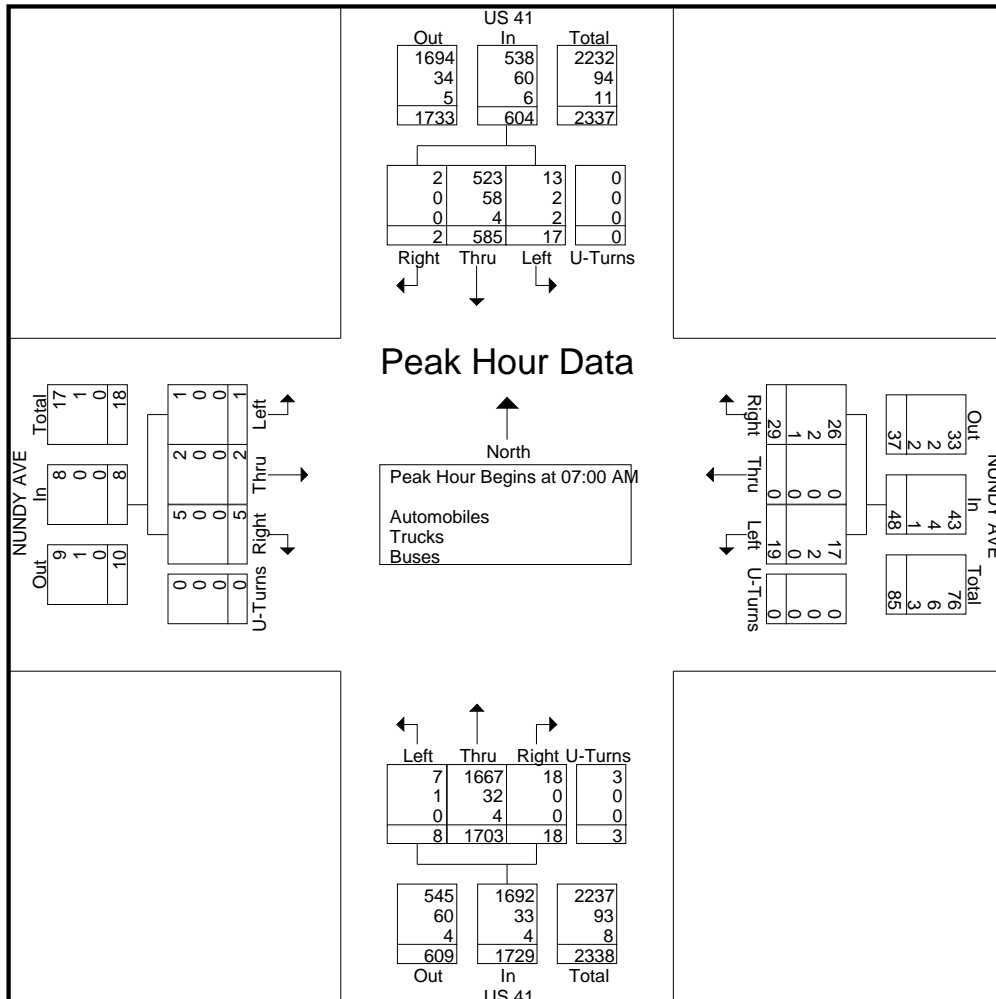





# Southern Traffic Services, Inc.

2911 Westfield Rd  
Gulf Breeze, FL 32563  
1-800-786-3374

*Traffic is our only business!*

US 41 @ Nundy Ave  
Tampa, FL

File Name : 13015-6 US 41 @ Nundy Ave  
Site Code : 13015-6  
Start Date : 1/9/2013  
Page No : 4

Start Time	US 41 Southbound					NUNDY AVE Westbound					US 41 Northbound					NUNDY AVE Eastbound					Int. Total
	Left	Thru	Right	U-Turns	App. Total	Left	Thru	Right	U-Turns	App. Total	Left	Thru	Right	U-Turns	App. Total	Left	Thru	Right	U-Turns	App. Total	

Peak Hour Analysis From 12:00 PM to 05:45 PM - Peak 1 of 1  
Peak Hour for Entire Intersection Begins at 04:45 PM

04:45 PM	12	370	0	0	382	10	1	5	0	16	4	207	9	0	220	0	0	2	0	2	620
05:00 PM	13	416	5	0	434	12	0	6	0	18	0	206	10	0	216	0	0	1	0	1	669
05:15 PM	9	482	1	0	492	10	1	8	0	19	3	177	9	0	189	4	0	2	0	6	706
05:30 PM	13	394	1	0	408	15	0	6	0	21	2	182	17	0	201	0	0	8	0	8	638
Total Volume	47	1662	7	0	1716	47	2	25	0	74	9	772	45	0	826	4	0	13	0	17	2633
% App. Total	2.7	96.9	0.4	0		63.5	2.7	33.8	0		1.1	93.5	5.4	0		23.5	0	76.5	0		
PHF	.904	.862	.350	.000	.872	.783	.500	.781	.000	.881	.563	.932	.662	.000	.939	.250	.000	.406	.000	.531	.932
Automobiles	43	1631	7	0	1681	47	2	23	0	72	9	728	44	0	781	4	0	13	0	17	2551
% Automobiles	91.5	98.1	100	0	98.0	100	100	92.0	0	97.3	100	94.3	97.8	0	94.6	100	0	100	0	100	96.9
Trucks	2	25	0	0	27	0	0	1	0	1	0	40	0	0	40	0	0	0	0	0	68
% Trucks	4.3	1.5	0	0	1.6	0	0	4.0	0	1.4	0	5.2	0	0	4.8	0	0	0	0	0	2.6
Buses	2	6	0	0	8	0	0	1	0	1	0	4	1	0	5	0	0	0	0	0	14
% Buses	4.3	0.4	0	0	0.5	0	0	4.0	0	1.4	0	0.5	2.2	0	0.6	0	0	0	0	0	0.5

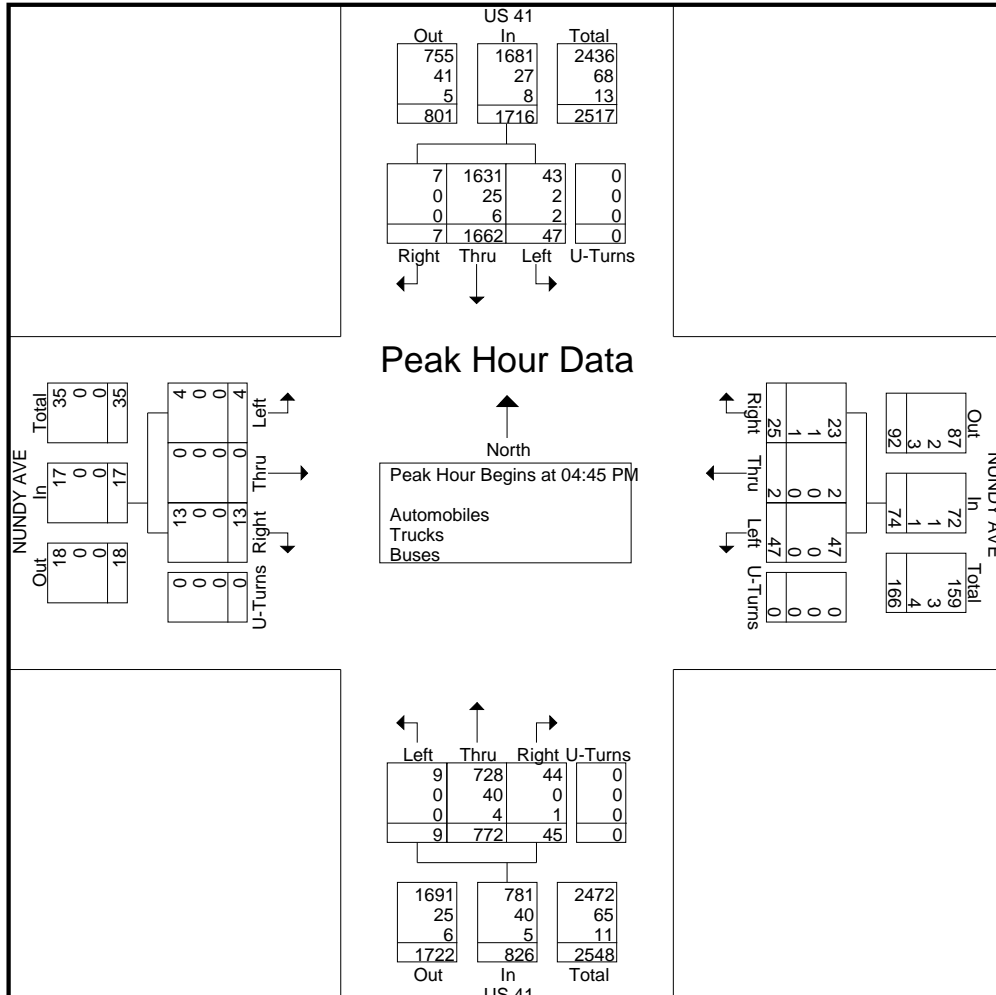



# Southern Traffic Services, Inc.

2911 Westfield Rd  
Gulf Breeze, FL 32563  
1-800-786-3374

*Traffic is our only business!*

US 41 @ Nundy Ave  
Tampa, FL

File Name : 13015-6 US 41 @ Nundy Ave  
Site Code : 13015-6  
Start Date : 1/9/2013  
Page No : 1

Groups Printed- Automobiles

Start Time	US 41 Southbound				NUNDY AVE Westbound				US 41 Northbound				NUNDY AVE Eastbound				Int. Total
	Left	Thru	Right	U-Turns	Left	Thru	Right	U-Turns	Left	Thru	Right	U-Turns	Left	Thru	Right	U-Turns	
07:00 AM	3	135	0	0	7	0	7	0	2	428	7	1	1	1	2	0	594
07:15 AM	3	121	0	0	4	0	9	0	3	395	2	2	0	0	1	0	540
07:30 AM	5	138	1	0	4	0	4	0	2	476	4	0	0	1	1	0	636
07:45 AM	2	129	1	0	2	0	6	0	0	368	5	0	0	0	1	0	514
<b>Total</b>	<b>13</b>	<b>523</b>	<b>2</b>	<b>0</b>	<b>17</b>	<b>0</b>	<b>26</b>	<b>0</b>	<b>7</b>	<b>1667</b>	<b>18</b>	<b>3</b>	<b>1</b>	<b>2</b>	<b>5</b>	<b>0</b>	<b>2284</b>
08:00 AM	5	76	0	0	2	0	8	0	5	321	5	1	0	0	0	0	423
08:15 AM	3	151	2	0	2	0	6	0	3	286	6	0	0	0	2	0	461
08:30 AM	4	136	0	0	3	0	2	0	1	247	3	1	3	0	0	0	400
08:45 AM	4	89	0	0	4	0	3	0	2	220	3	0	0	0	0	0	325
<b>Total</b>	<b>16</b>	<b>452</b>	<b>2</b>	<b>0</b>	<b>11</b>	<b>0</b>	<b>19</b>	<b>0</b>	<b>11</b>	<b>1074</b>	<b>17</b>	<b>2</b>	<b>3</b>	<b>0</b>	<b>2</b>	<b>0</b>	<b>1609</b>
<b>**BREAK**</b>																	
04:00 PM	9	313	1	0	14	0	5	0	1	164	9	0	1	0	0	0	517
04:15 PM	11	322	3	0	16	0	9	0	1	169	13	0	0	0	1	0	545
04:30 PM	15	364	4	0	13	0	5	0	0	163	16	0	1	0	0	0	581
04:45 PM	10	362	0	0	10	1	5	0	4	194	9	0	0	0	2	0	597
<b>Total</b>	<b>45</b>	<b>1361</b>	<b>8</b>	<b>0</b>	<b>53</b>	<b>1</b>	<b>24</b>	<b>0</b>	<b>6</b>	<b>690</b>	<b>47</b>	<b>0</b>	<b>2</b>	<b>0</b>	<b>3</b>	<b>0</b>	<b>2240</b>
05:00 PM	13	406	5	0	12	0	5	0	0	195	10	0	0	0	1	0	647
05:15 PM	7	473	1	0	10	1	7	0	3	169	9	0	4	0	2	0	686
05:30 PM	13	390	1	0	15	0	6	0	2	170	16	0	0	0	8	0	621
05:45 PM	11	405	1	0	8	0	5	0	3	133	16	0	3	1	1	0	587
<b>Total</b>	<b>44</b>	<b>1674</b>	<b>8</b>	<b>0</b>	<b>45</b>	<b>1</b>	<b>23</b>	<b>0</b>	<b>8</b>	<b>667</b>	<b>51</b>	<b>0</b>	<b>7</b>	<b>1</b>	<b>12</b>	<b>0</b>	<b>2541</b>
<b>Grand Total</b>	<b>118</b>	<b>4010</b>	<b>20</b>	<b>0</b>	<b>126</b>	<b>2</b>	<b>92</b>	<b>0</b>	<b>32</b>	<b>4098</b>	<b>133</b>	<b>5</b>	<b>13</b>	<b>3</b>	<b>22</b>	<b>0</b>	<b>8674</b>
Apprch %	2.8	96.7	0.5	0	57.3	0.9	41.8	0	0.7	96	3.1	0.1	34.2	7.9	57.9	0	
Total %	1.4	46.2	0.2	0	1.5	0	1.1	0	0.4	47.2	1.5	0.1	0.1	0	0.3	0	



# Southern Traffic Services, Inc.

2911 Westfield Rd  
Gulf Breeze, FL 32563  
1-800-786-3374

*Traffic is our only business!*

US 41 @ Nundy Ave  
Tampa, FL

File Name : 13015-6 US 41 @ Nundy Ave  
Site Code : 13015-6  
Start Date : 1/9/2013  
Page No : 2

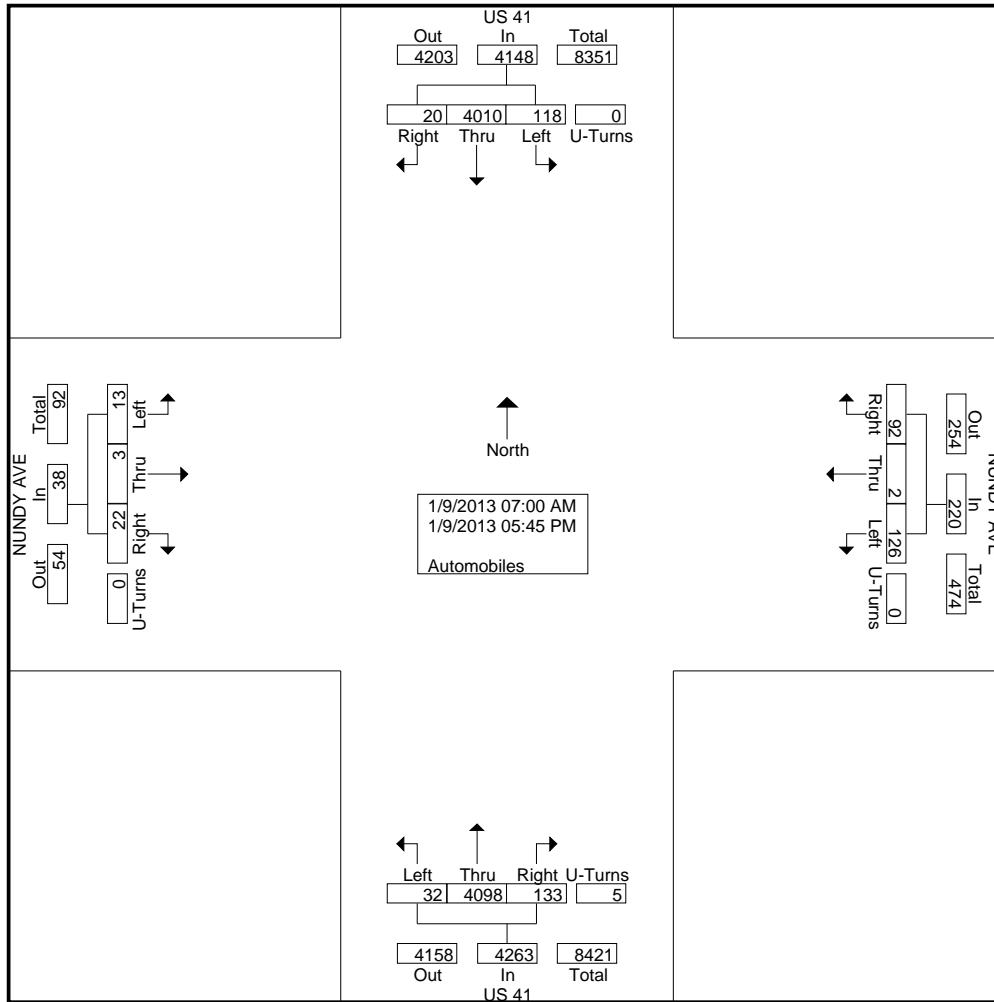



# Southern Traffic Services, Inc.

2911 Westfield Rd  
 Gulf Breeze, FL 32563  
 1-800-786-3374

*Traffic is our only business!*

US 41 @ Nundy Ave  
 Tampa, FL

File Name : 13015-6 US 41 @ Nundy Ave  
 Site Code : 13015-6  
 Start Date : 1/9/2013  
 Page No : 3

Start Time	US 41 Southbound				NUNDY AVE Westbound				US 41 Northbound				NUNDY AVE Eastbound				Int. Total				
	Thru	Right	U-Turns	App. Total	Left	Thru	Right	U-Turns	App. Total	Left	Thru	Right	U-Turns	App. Total	Left	Thru		Right	U-Turns	App. Total	
Peak Hour Analysis From 07:00 AM to 11:45 AM - Peak 1 of 1																					
Peak Hour for Entire Intersection Begins at 07:00 AM																					
07:00 AM	3	135	0	0	138	7	0	7	0	14	2	428	7	1	438	1	1	2	0	4	594
07:15 AM	3	121	0	0	124	4	0	9	0	13	3	395	2	2	402	0	0	1	0	1	540
07:30 AM	5	138	1	0	144	4	0	4	0	8	2	476	4	0	482	0	1	1	0	2	636
07:45 AM	2	129	1	0	132	2	0	6	0	8	0	368	5	0	373	0	0	1	0	1	514
Total Volume	13	523	2	0	538	17	0	26	0	43	7	1667	18	3	1695	1	2	5	0	8	2284
% App. Total	2.4	97.2	0.4	0		39.5	0	60.5	0		0.4	98.3	1.1	0.2		12.5	25	62.5	0		
PHF	.650	.947	.500	.000	.934	.607	.000	.722	.000	.768	.583	.876	.643	.375	.879	.250	.500	.625	.000	.500	.898

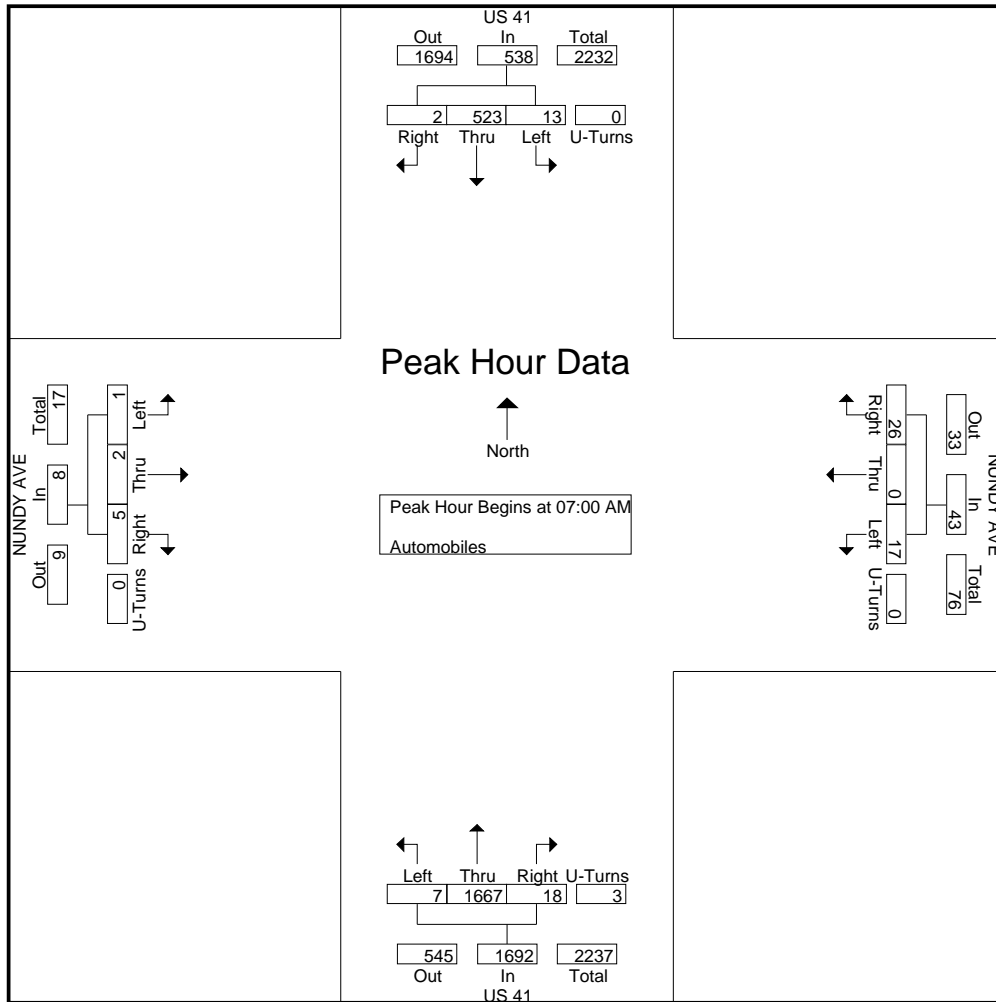



# Southern Traffic Services, Inc.

2911 Westfield Rd  
 Gulf Breeze, FL 32563  
 1-800-786-3374

*Traffic is our only business!*

US 41 @ Nundy Ave  
 Tampa, FL

File Name : 13015-6 US 41 @ Nundy Ave  
 Site Code : 13015-6  
 Start Date : 1/9/2013  
 Page No : 4

Start Time	US 41 Southbound					NUNDY AVE Westbound					US 41 Northbound					NUNDY AVE Eastbound					Int. Total
	Left	Thru	Right	U-Turns	App. Total	Left	Thru	Right	U-Turns	App. Total	Left	Thru	Right	U-Turns	App. Total	Left	Thru	Right	U-Turns	App. Total	
Peak Hour Analysis From 12:00 PM to 05:45 PM - Peak 1 of 1																					
Peak Hour for Entire Intersection Begins at 04:45 PM																					
04:45 PM	10	362	0	0	372	10	1	5	0	16	4	194	9	0	207	0	0	2	0	2	597
05:00 PM	13	406	5	0	424	12	0	5	0	17	0	195	10	0	205	0	0	1	0	1	647
05:15 PM	7	473	1	0	481	10	1	7	0	18	3	169	9	0	181	4	0	2	0	6	686
05:30 PM	13	390	1	0	404	15	0	6	0	21	2	170	16	0	188	0	0	8	0	8	621
Total Volume	43	1631	7	0	1681	47	2	23	0	72	9	728	44	0	781	4	0	13	0	17	2551
% App. Total	2.6	97	0.4	0		65.3	2.8	31.9	0		1.2	93.2	5.6	0		23.5	0	76.5	0		
PHF	.827	.862	.350	.000	.874	.783	.500	.821	.000	.857	.563	.933	.688	.000	.943	.250	.000	.406	.000	.531	.930

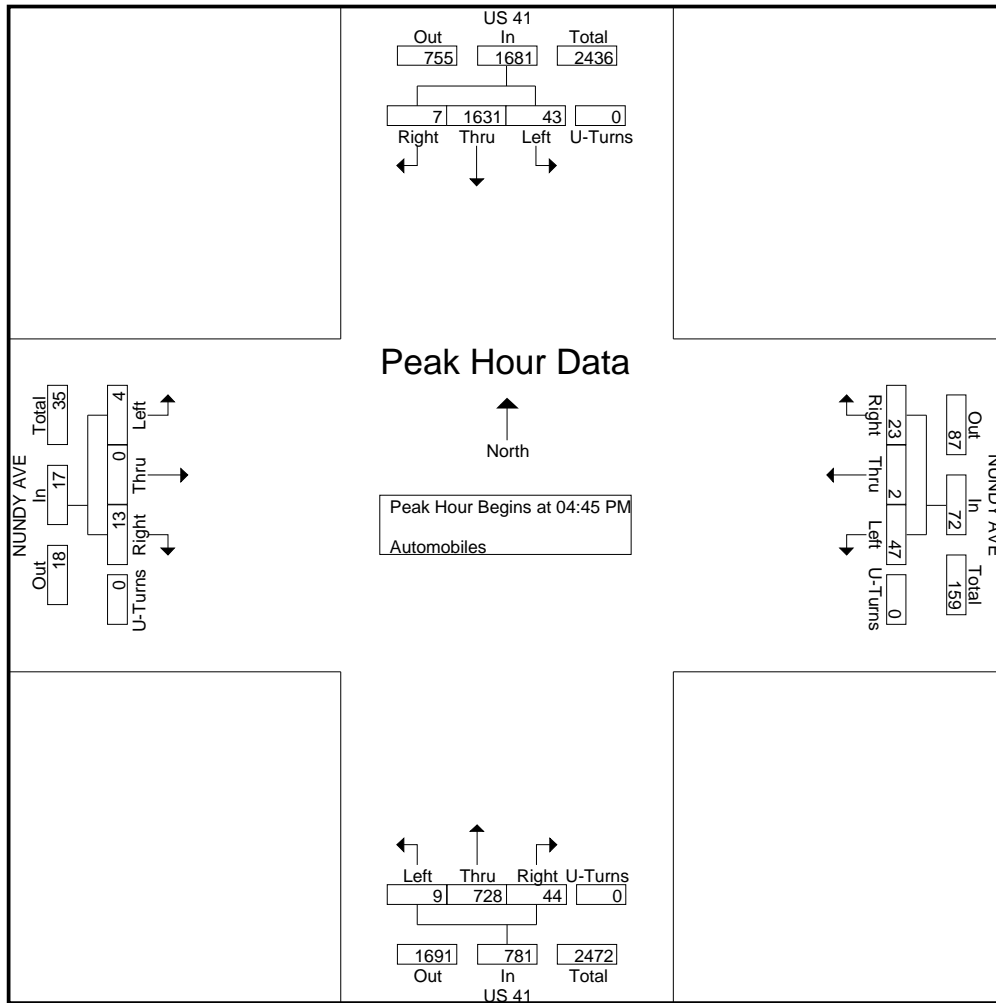





# Southern Traffic Services, Inc.

2911 Westfield Rd  
 Gulf Breeze, FL 32563  
 1-800-786-3374

*Traffic is our only business!*

US 41 @ Nundy Ave  
 Tampa, FL

File Name : 13015-6 US 41 @ Nundy Ave  
 Site Code : 13015-6  
 Start Date : 1/9/2013  
 Page No : 2

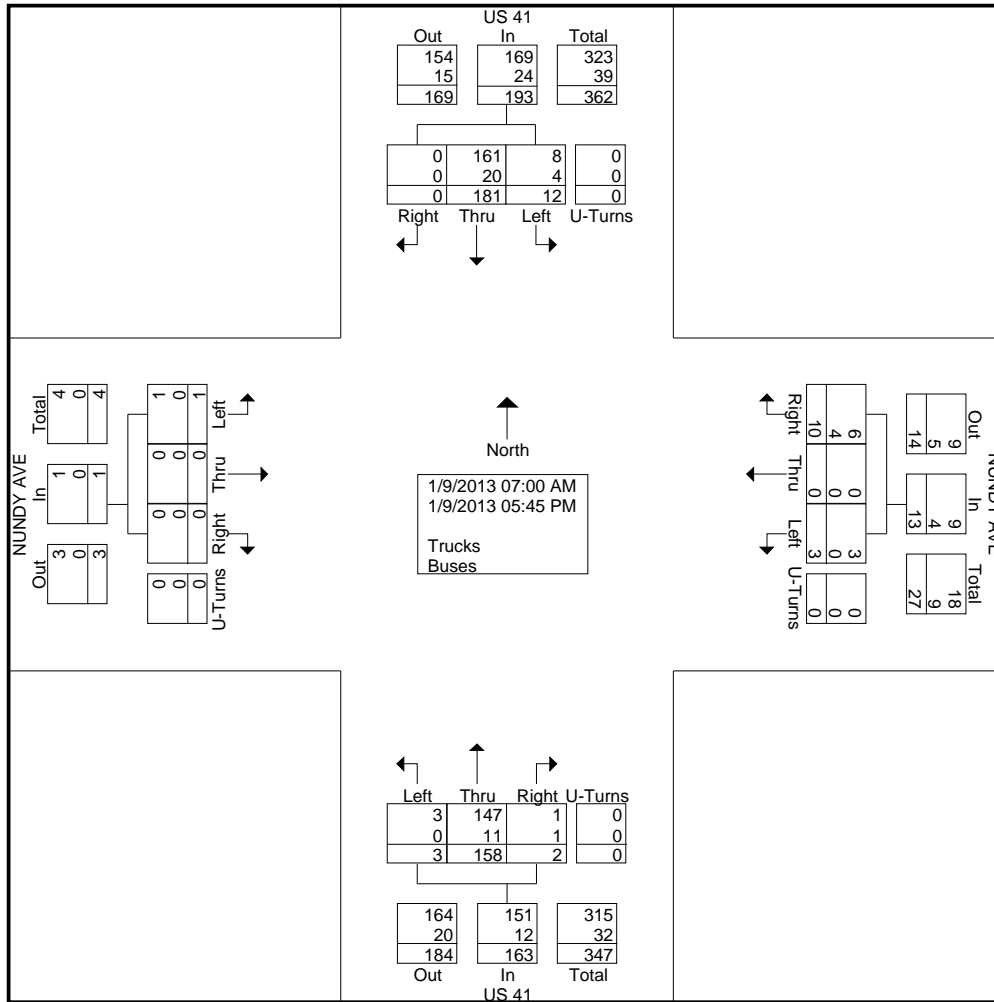



# Southern Traffic Services, Inc.

2911 Westfield Rd  
Gulf Breeze, FL 32563  
1-800-786-3374

*Traffic is our only business!*

US 41 @ Nundy Ave  
Tampa, FL

File Name : 13015-6 US 41 @ Nundy Ave  
Site Code : 13015-6  
Start Date : 1/9/2013  
Page No : 3

Start Time	US 41 Southbound				NUNDY AVE Westbound				US 41 Northbound				NUNDY AVE Eastbound				Int. Total				
	Thru	Right	U-Turns	App. Total	Left	Thru	Right	U-Turns	App. Total	Left	Thru	Right	U-Turns	App. Total	Left	Thru		Right	U-Turns	App. Total	
Peak Hour Analysis From 07:00 AM to 11:45 AM - Peak 1 of 1																					
Peak Hour for Entire Intersection Begins at 07:30 AM																					
07:30 AM	2	14	0	0	16	0	0	1	0	1	0	8	0	0	8	0	0	0	0	0	25
07:45 AM	0	18	0	0	18	1	0	0	0	1	1	11	0	0	12	0	0	0	0	0	31
08:00 AM	0	18	0	0	18	0	0	1	0	1	0	13	0	0	13	0	0	0	0	0	32
08:15 AM	1	15	0	0	16	0	0	0	0	0	1	13	0	0	14	0	0	0	0	0	30
Total Volume	3	65	0	0	68	1	0	2	0	3	2	45	0	0	47	0	0	0	0	0	118
% App. Total	4.4	95.6	0	0		33.3	0	66.7	0		4.3	95.7	0	0		0	0	0	0		
PHF	.375	.903	.000	.000	.944	.250	.000	.500	.000	.750	.500	.865	.000	.000	.839	.000	.000	.000	.000	.000	.922
Trucks	3	58	0	0	61	1	0	1	0	2	2	41	0	0	43	0	0	0	0	0	106
% Trucks	100	89.2	0	0	89.7	100	0	50.0	0	66.7	100	91.1	0	0	91.5	0	0	0	0	0	89.8
Buses	0	7	0	0	7	0	0	1	0	1	0	4	0	0	4	0	0	0	0	0	12
% Buses	0	10.8	0	0	10.3	0	0	50.0	0	33.3	0	8.9	0	0	8.5	0	0	0	0	0	10.2

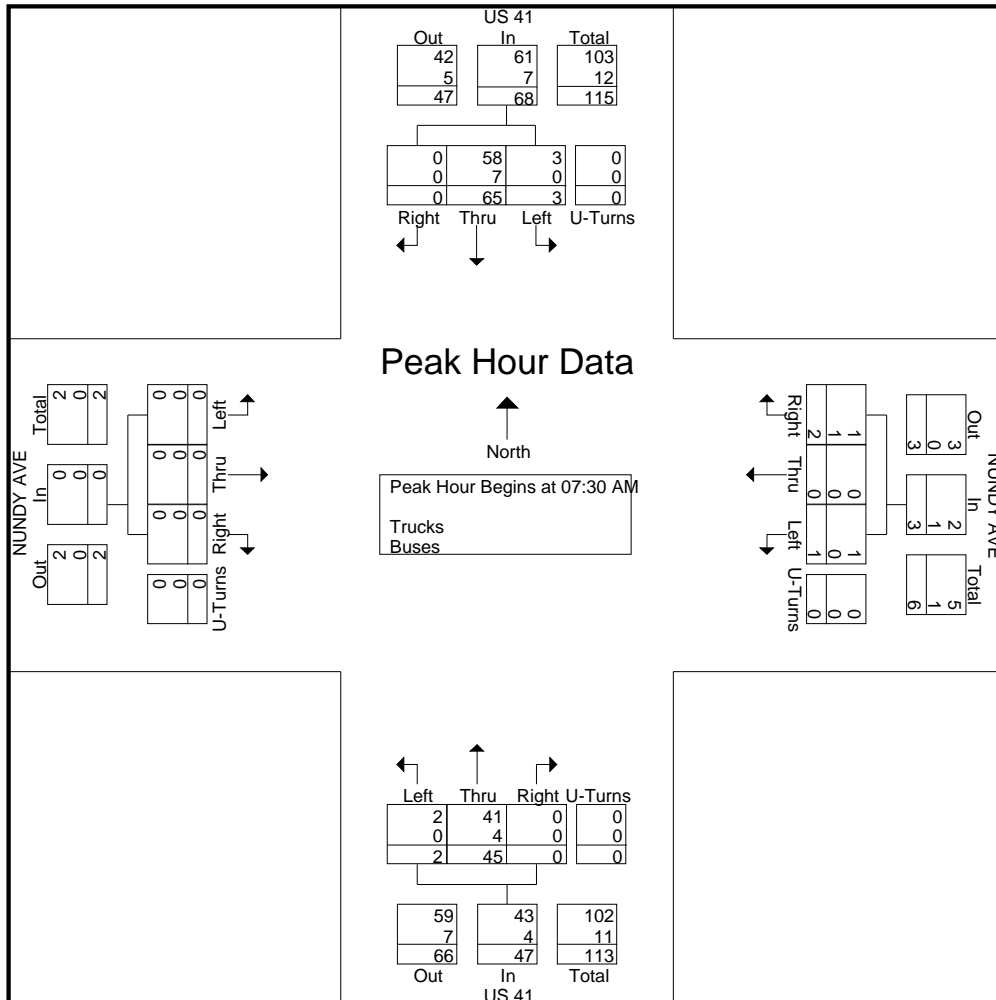





# Southern Traffic Services, Inc.

2911 Westfield Rd  
Gulf Breeze, FL 32563  
1-800-786-3374

*Traffic is our only business!*

US 41 @ Nundy Ave  
Tampa, FL

File Name : 13015-6 US 41 @ Nundy Ave  
Site Code : 13015-6  
Start Date : 1/9/2013  
Page No : 4

Start Time	US 41 Southbound					NUNDY AVE Westbound					US 41 Northbound					NUNDY AVE Eastbound					Int. Total
	Left	Thru	Right	U-Turns	App. Total	Left	Thru	Right	U-Turns	App. Total	Left	Thru	Right	U-Turns	App. Total	Left	Thru	Right	U-Turns	App. Total	

Peak Hour Analysis From 12:00 PM to 05:45 PM - Peak 1 of 1  
Peak Hour for Entire Intersection Begins at 04:00 PM

04:00 PM	0	10	0	0	10	1	0	1	0	2	0	17	0	0	17	0	0	0	0	0	29
04:15 PM	0	11	0	0	11	0	0	0	0	0	1	11	0	0	12	0	0	0	0	0	23
04:30 PM	0	6	0	0	6	0	0	0	0	0	0	14	0	0	14	1	0	0	0	1	21
04:45 PM	2	8	0	0	10	0	0	0	0	0	0	13	0	0	13	0	0	0	0	0	23
Total Volume	2	35	0	0	37	1	0	1	0	2	1	55	0	0	56	1	0	0	0	1	96
% App. Total	5.4	94.6	0	0		50	0	50	0		1.8	98.2	0	0		100	0	0	0		
PHF	.250	.795	.000	.000	.841	.250	.000	.250	.000	.250	.250	.809	.000	.000	.824	.250	.000	.000	.000	.250	.828
Trucks	0	27	0	0	27	1	0	1	0	2	1	53	0	0	54	1	0	0	0	1	84
% Trucks	0	77.1	0	0	73.0	100	0	100	0	100	100	96.4	0	0	96.4	100	0	0	0	100	87.5
Buses	2	8	0	0	10	0	0	0	0	0	0	2	0	0	2	0	0	0	0	0	12
% Buses	100	22.9	0	0	27.0	0	0	0	0	0	0	3.6	0	0	3.6	0	0	0	0	0	12.5

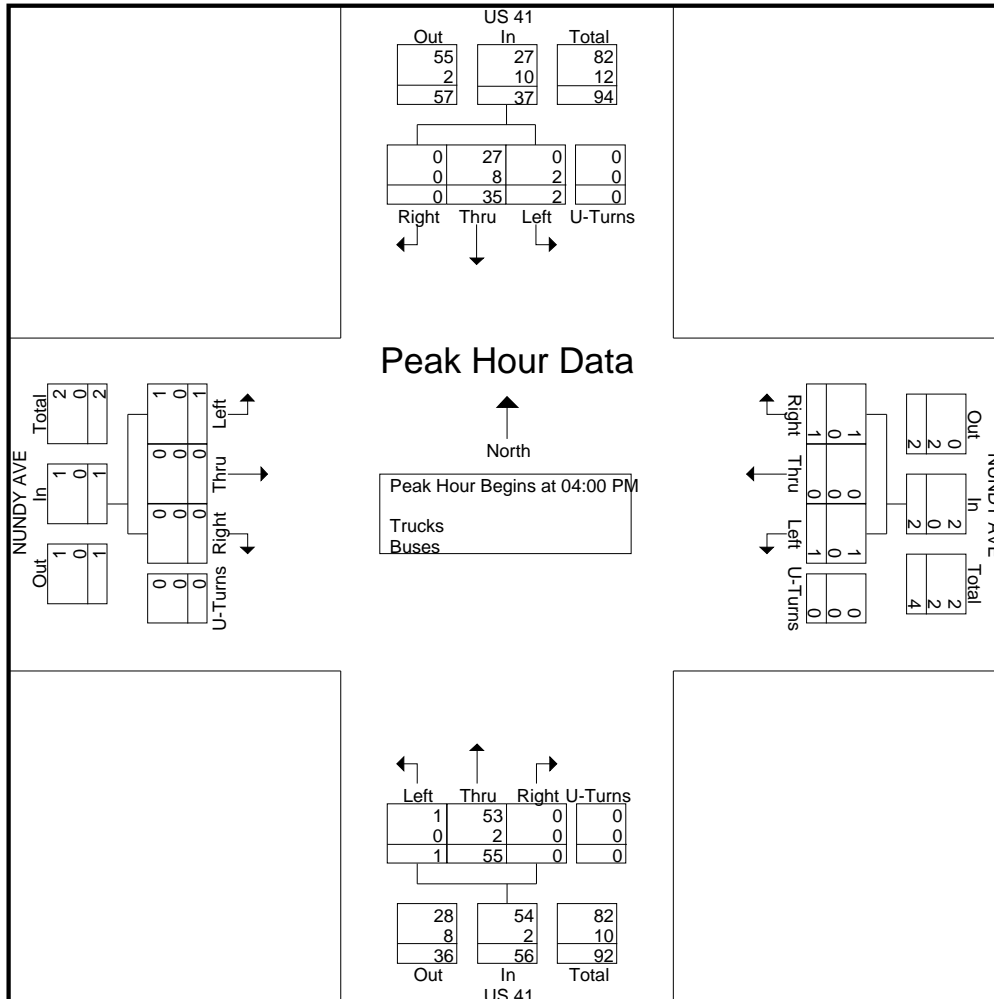



# Southern Traffic Services, Inc.

2911 Westfield Rd  
Gulf Breeze, FL 32563  
1-800-786-3374

*Traffic is our only business!*

US 41 @ Nundy Ave  
Tampa, FL

File Name : 13015-6 US 41 @ Nundy Ave Peds  
Site Code : 13015-6  
Start Date : 1/9/2013  
Page No : 1

Groups Printed- Peds

Start Time	US 41	NUNDY AVE	US 41	NUNDY AVE	Int. Total
	Southbound	Westbound	Northbound	Eastbound	
	Peds	Peds	Peds	Peds	
07:00 AM	0	0	1	0	1
07:15 AM	0	0	0	0	0
07:30 AM	0	0	0	1	1
07:45 AM	0	0	0	3	3
Total	0	0	1	4	5
08:00 AM	0	0	0	0	0
08:15 AM	0	0	0	2	2
08:30 AM	0	0	0	2	2
08:45 AM	0	0	0	0	0
Total	0	0	0	4	4
09:00 AM	0	0	0	0	0
09:15 AM	0	0	0	0	0
09:30 AM	0	0	0	0	0
09:45 AM	0	0	0	0	0
Total	0	0	0	0	0
10:00 AM	0	0	0	0	0
10:15 AM	0	0	0	0	0
10:30 AM	0	0	0	0	0
10:45 AM	0	0	0	0	0
Total	0	0	0	0	0
11:00 AM	0	0	0	0	0
11:15 AM	0	0	0	0	0
11:30 AM	0	0	0	0	0
11:45 AM	0	0	0	0	0
Total	0	0	0	0	0
12:00 PM	0	0	0	0	0
12:15 PM	0	0	0	0	0
12:30 PM	0	0	0	0	0
12:45 PM	0	0	0	0	0
Total	0	0	0	0	0
01:00 PM	0	0	0	0	0
01:15 PM	0	0	0	0	0
01:30 PM	0	0	0	0	0
01:45 PM	0	0	0	0	0
Total	0	0	0	0	0
02:00 PM	0	0	0	0	0
02:15 PM	0	0	0	0	0
02:30 PM	0	0	0	0	0
02:45 PM	0	0	0	0	0
Total	0	0	0	0	0
03:00 PM	0	0	0	0	0
03:15 PM	0	0	0	0	0
03:30 PM	0	0	0	0	0
03:45 PM	0	0	0	0	0
Total	0	0	0	0	0



# Southern Traffic Services, Inc.

2911 Westfield Rd  
 Gulf Breeze, FL 32563  
 1-800-786-3374

*Traffic is our only business!*

US 41 @ Nundy Ave  
 Tampa, FL

File Name : 13015-6 US 41 @ Nundy Ave Peds  
 Site Code : 13015-6  
 Start Date : 1/9/2013  
 Page No : 2

Groups Printed- Peds

Start Time	US 41 Southbound	NUNDY AVE Westbound	US 41 Northbound	NUNDY AVE Eastbound	Int. Total
	Peds	Peds	Peds	Peds	
04:00 PM	0	2	0	4	6
04:15 PM	0	2	0	5	7
04:30 PM	0	0	0	3	3
04:45 PM	0	1	0	0	1
Total	0	5	0	12	17
05:00 PM	0	1	0	1	2
05:15 PM	0	0	0	4	4
05:30 PM	0	1	0	2	3
05:45 PM	0	1	0	2	3
Total	0	3	0	9	12
Grand Total	0	8	1	29	38
Aprch %	0	100	100	100	
Total %	0	21.1	2.6	76.3	

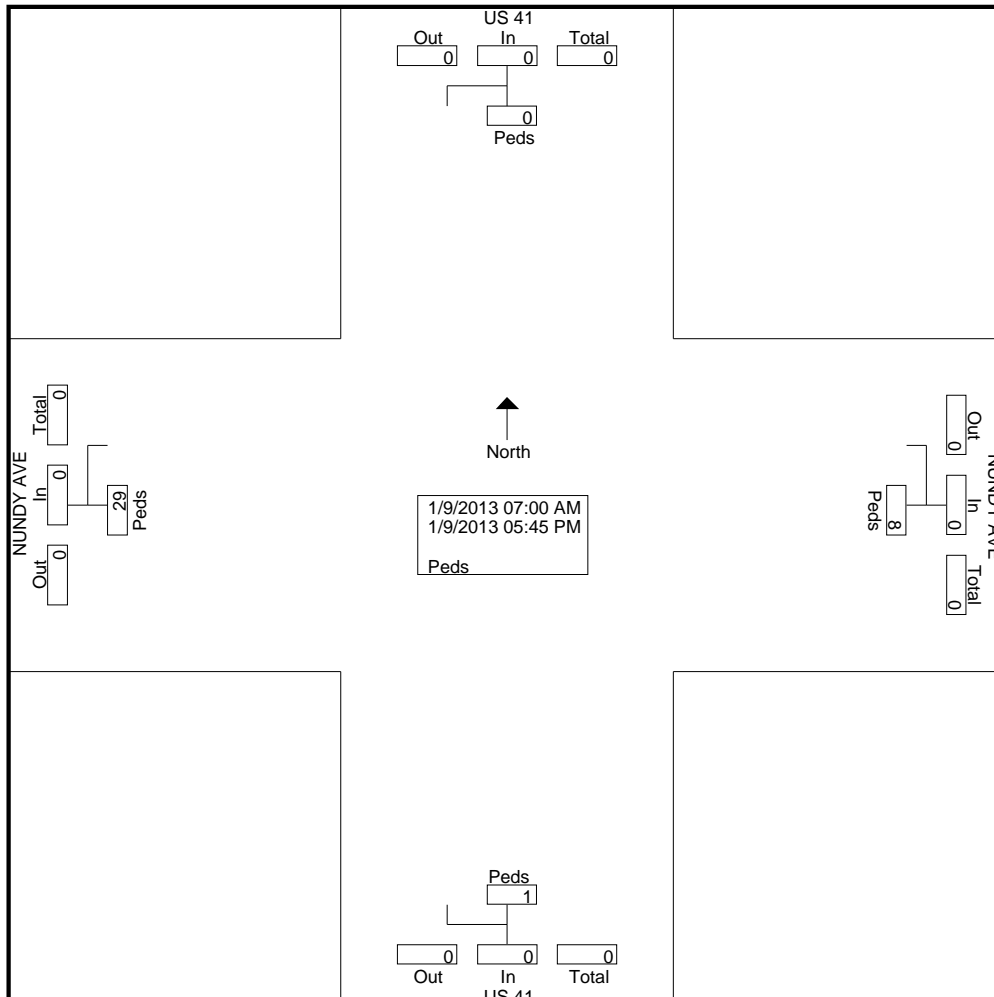

# Southern Traffic Services, Inc.

## Event Counts

US 41 north of Nundy Avenue

Northbound

**Datasets:**

**Site:** [061] !c9120  
**Input A:** 7 - North bound A>B, South bound B>A. - Added to totals. (1)  
**Input B:** 0 - Unused or unknown. - Excluded from totals. (0)  
**Survey Duration:** 13:16 Monday, January 07, 2013 => 11:04 Friday, January 11, 2013  
**File:** G:\DATA\2013\Private\13015\marco\Jan -11-2013 DATA\UM061.eco (Plus)  
**Identifier:** AP81MAEF MC56-L5 [MC55] (c)Microcom 19Oct04  
**Algorithm:** Event Count  
**Data type:** Axle sensors - Paired (Class, Speed, Count)

**Profile:**

**Filter time:** 0:00 Tuesday, January 08, 2013 => 0:00 Friday, January 11, 2013  
**Name:** Factory default profile  
**Scheme:** Count events divided by two.  
**Units:** Non metric (ft, mi, ft/s, mph, lb, ton)  
**In profile:** Events = 42586

**Tuesday, January 08, 2013=14137, 15 minute drops**

0000	0100	0200	0300	0400	0500	0600	0700	0800	0900	1000	1100	1200	1300	1400	1500	1600	1700	1800	1900	2000	2100	2200	2300	
58	41	28	76	169	584	1444	1841	1196	793	724	726	748	781	791	903	790	831	552	341	249	216	141	114	
15	10	9	16	20	101	271	435	358	108	180	185	174	188	184	232	196	218	173	101	60	64	40	27	17
12	12	3	17	44	131	373	484	337	251	192	178	177	201	211	208	179	228	144	88	61	56	40	28	18
23	11	10	22	52	158	373	530	254	225	169	174	210	198	198	230	207	210	130	102	66	47	33	42	14
8	8	6	21	53	194	427	392	247	209	183	189	187	194	198	233	208	175	105	50	62	49	28	17	13

AM Peak 0645 - 0745 (1876), AM PHF=0.88 PM Peak 1500 - 1600 (903), PM PHF=0.97

**Wednesday, January 09, 2013=14146, 15 minute drops**

0000	0100	0200	0300	0400	0500	0600	0700	0800	0900	1000	1100	1200	1300	1400	1500	1600	1700	1800	1900	2000	2100	2200	2300	
62	43	46	81	172	623	1366	1801	1191	781	767	700	705	775	777	861	784	855	618	357	270	237	162	112	
17	12	11	4	24	102	248	420	366	202	209	170	172	207	202	201	217	249	155	123	62	81	45	30	21
18	12	11	31	36	133	345	474	315	201	194	186	173	203	185	191	184	220	162	88	78	65	46	30	10
14	11	12	29	58	170	393	497	264	203	180	164	185	185	202	231	188	219	151	80	64	51	32	23	11
13	8	12	17	54	218	380	410	246	175	184	180	175	180	188	238	195	167	150	66	66	40	39	29	10

AM Peak 0700 - 0800 (1801), AM PHF=0.91 PM Peak 1645 - 1745 (883), PM PHF=0.89

**Thursday, January 10, 2013=14303, 15 minute drops**

0000	0100	0200	0300	0400	0500	0600	0700	0800	0900	1000	1100	1200	1300	1400	1500	1600	1700	1800	1900	2000	2100	2200	2300	
52	45	41	62	167	591	1393	1935	1191	783	735	729	732	780	810	884	793	775	636	349	303	245	164	108	
21	8	9	11	21	97	237	526	368	204	160	177	184	198	184	186	189	220	188	85	66	69	42	32	10
10	8	9	18	31	115	343	465	347	202	224	182	171	172	184	229	196	197	169	112	72	61	41	29	23
11	17	10	22	62	161	385	476	253	196	90	193	202	207	232	257	199	185	132	79	79	52	43	32	12
10	12	13	11	53	218	428	468	223	181	261	177	175	203	210	212	209	173	147	73	86	63	38	15	13

AM Peak 0700 - 0800 (1935), AM PHF=0.92 PM Peak 1515 - 1615 (887), PM PHF=0.86

# Southern Traffic Services, Inc.

## Event Counts

US 41 north of Nundy Avenue

Southbound

**Datasets:**

**Site:** [061] !c9120  
**Input A:** 7 - North bound A>B, South bound B>A. - Excluded from totals. (0)  
**Input B:** 0 - Unused or unknown. - Added to totals. (1)  
**Survey Duration:** 13:16 Monday, January 07, 2013 => 11:04 Friday, January 11, 2013  
**File:** G:\DATA\2013\Private\13015\marco\Jan -11-2013 DATA\UM061.eco (Plus)  
**Identifier:** AP81MAEF MC56-L5 [MC55] (c)Microcom 19Oct04  
**Algorithm:** Event Count  
**Data type:** Axle sensors - Paired (Class, Speed, Count)

**Profile:**

**Filter time:** 0:00 Tuesday, January 08, 2013 => 0:00 Friday, January 11, 2013  
**Name:** Factory default profile  
**Scheme:** Count events divided by two.  
**Units:** Non metric (ft, mi, ft/s, mph, lb, ton)  
**In profile:** Events = 43074

**Tuesday, January 08, 2013=14324, 15 minute drops**

0000	0100	0200	0300	0400	0500	0600	0700	0800	0900	1000	1100	1200	1300	1400	1500	1600	1700	1800	1900	2000	2100	2200	2300	
171	70	46	71	105	217	529	630	604	582	581	694	684	730	793	1165	1546	1766	1292	678	512	373	289	196	
50	19	8	17	19	31	118	158	141	140	128	155	184	169	174	194	377	421	403	194	140	93	97	50	32
76	16	10	12	24	40	129	157	160	142	153	181	172	125	237	286	345	503	374	169	154	90	79	51	36
26	18	19	25	28	66	142	146	171	143	149	183	153	275	186	340	395	432	264	145	112	91	62	57	17
19	17	9	17	34	80	140	169	132	157	151	175	175	161	196	345	429	410	251	170	106	99	51	38	19

AM Peak 1115 - 1215 (723), AM PHF=0.98 PM Peak 1645 - 1745 (1785), PM PHF=0.89

**Wednesday, January 09, 2013=14357, 15 minute drops**

0000	0100	0200	0300	0400	0500	0600	0700	0800	0900	1000	1100	1200	1300	1400	1500	1600	1700	1800	1900	2000	2100	2200	2300	
104	73	64	52	85	253	542	654	656	555	627	621	704	718	810	1164	1465	1769	1215	668	547	440	345	226	
32	24	19	8	11	30	106	156	149	134	151	148	199	194	188	226	345	415	399	185	154	114	103	59	38
36	18	19	20	21	35	128	152	174	142	160	179	154	168	203	262	363	497	327	118	137	112	87	48	36
17	21	16	12	19	81	163	181	188	121	142	179	170	179	203	334	383	429	253	219	131	119	87	74	25
19	10	10	12	34	107	145	165	145	158	174	115	181	177	216	342	374	428	236	146	125	95	68	45	31

AM Peak 1045 - 1145 (680), AM PHF=0.95 PM Peak 1700 - 1800 (1769), PM PHF=0.89

**Thursday, January 10, 2013=14393, 15 minute drops**

0000	0100	0200	0300	0400	0500	0600	0700	0800	0900	1000	1100	1200	1300	1400	1500	1600	1700	1800	1900	2000	2100	2200	2300	
130	88	65	48	89	212	534	656	543	577	590	641	732	720	890	1165	1470	1768	1249	753	547	397	318	211	
38	28	18	11	12	34	113	161	104	177	138	152	173	176	203	242	346	434	355	244	141	118	72	15	40
36	21	13	10	17	35	153	183	183	123	144	156	209	191	248	282	375	433	303	205	146	117	85	98	46
25	21	21	15	28	59	148	167	152	142	134	167	192	107	193	301	347	489	306	163	137	86	82	52	36
31	18	13	12	32	84	120	145	104	135	174	166	158	246	246	340	402	412	285	141	123	76	79	46	25

AM Peak 1145 - 1245 (740), AM PHF=0.89 PM Peak 1700 - 1800 (1768), PM PHF=0.90

# Southern Traffic Services, Inc.

## Event Counts

**US 41 south of Nundy Avenue**

**Northbound**

**Datasets:**

**Site:** [062] !C6002  
**Input A:** 7 - North bound A>B, South bound B>A. - Excluded from totals. (0)  
**Input B:** 0 - Unused or unknown. - Added to totals. (1)  
**Survey Duration:** 8:01 Monday, January 07, 2013 => 10:47 Friday, January 11, 2013  
**File:** G:\DATA\2013\Private\13015\marco\Jan -11-2013 DATA\UM062.eco (Plus)  
**Identifier:** R703SPKS MC56-L5 [MC55] (c)Microcom 19Oct04  
**Algorithm:** Event Count  
**Data type:** Axle sensors - Paired (Class, Speed, Count)

**Profile:**

**Filter time:** 0:00 Tuesday, January 08, 2013 => 0:00 Friday, January 11, 2013  
**Name:** Factory default profile  
**Scheme:** Count events divided by two.  
**Units:** Non metric (ft, mi, ft/s, mph, lb, ton)  
**In profile:** Events = 43668

**Tuesday, January 08, 2013=14507, 15 minute drops**

0000	0100	0200	0300	0400	0500	0600	0700	0800	0900	1000	1100	1200	1300	1400	1500	1600	1700	1800	1900	2000	2100	2200	2300	
61	40	28	79	173	584	1412	1799	1181	809	739	772	778	844	857	938	831	864	592	369	266	228	143	120	
18	12	9	16	21	97	265	419	344	100	170	184	174	206	200	226	215	235	175	104	57	66	39	33	15
14	12	3	18	38	131	336	456	330	277	200	209	198	218	240	221	191	225	170	103	64	64	39	27	20
19	9	11	26	56	157	384	527	275	206	192	184	210	216	217	245	207	214	137	103	76	46	34	37	18
10	7	5	19	58	199	427	397	232	226	177	195	196	204	200	246	218	190	110	59	69	52	31	23	11

AM Peak 0645 - 0745 (1829), AM PHF=0.87 PM Peak 1500 - 1600 (938), PM PHF=0.95

**Wednesday, January 09, 2013=14546, 15 minute drops**

0000	0100	0200	0300	0400	0500	0600	0700	0800	0900	1000	1100	1200	1300	1400	1500	1600	1700	1800	1900	2000	2100	2200	2300	
64	44	47	84	175	621	1331	1749	1196	827	784	705	753	819	800	931	847	902	645	383	292	263	172	112	
15	13	10	6	24	101	245	412	352	219	212	180	164	212	224	209	221	264	170	130	67	84	50	36	18
20	13	11	33	42	127	340	450	326	206	187	179	200	209	174	203	206	245	158	92	87	69	48	26	11
18	9	14	25	53	170	396	488	266	191	193	163	192	213	209	253	196	219	159	91	74	56	39	22	10
11	9	12	20	56	223	350	399	252	211	192	183	197	185	193	266	224	174	158	70	64	54	35	28	13

AM Peak 0700 - 0800 (1749), AM PHF=0.90 PM Peak 1645 - 1745 (952), PM PHF=0.90

**Thursday, January 10, 2013=14615, 15 minute drops**

0000	0100	0200	0300	0400	0500	0600	0700	0800	0900	1000	1100	1200	1300	1400	1500	1600	1700	1800	1900	2000	2100	2200	2300	
52	48	42	64	174	582	1314	1840	1173	812	750	800	753	812	868	950	861	799	654	373	328	266	189	111	
18	9	10	13	22	91	250	486	356	210	185	195	175	197	215	202	208	229	188	91	69	72	47	33	18
11	9	10	19	38	119	323	451	323	213	209	215	191	197	177	247	210	192	183	117	82	68	42	28	20
10	20	11	21	63	161	386	490	256	206	81	201	193	211	262	270	210	204	136	83	86	61	47	30	11
13	10	11	11	51	211	355	413	238	183	275	189	194	207	214	231	233	174	147	82	91	65	53	20	18

AM Peak 0700 - 0800 (1840), AM PHF=0.94 PM Peak 1515 - 1615 (956), PM PHF=0.89

# Southern Traffic Services, Inc.

## Event Counts

US 41 south of Nundy Avenue

Southbound

**Datasets:**

**Site:** [062] !C6002  
**Input A:** 7 - North bound A>B, South bound B>A. - Added to totals. (1)  
**Input B:** 0 - Unused or unknown. - Excluded from totals. (0)  
**Survey Duration:** 8:01 Monday, January 07, 2013 => 10:47 Friday, January 11, 2013  
**File:** G:\DATA\2013\Private\13015\marco\Jan -11-2013 DATA\UM062.eco (Plus)  
**Identifier:** R703SPKS MC56-L5 [MC55] (c)Microcom 19Oct04  
**Algorithm:** Event Count  
**Data type:** Axle sensors - Paired (Class, Speed, Count)

**Profile:**

**Filter time:** 0:00 Tuesday, January 08, 2013 => 0:00 Friday, January 11, 2013  
**Name:** Factory default profile  
**Scheme:** Count events divided by two.  
**Units:** Non metric (ft, mi, ft/s, mph, lb, ton)  
**In profile:** Events = 44427

**Tuesday, January 08, 2013=14745, 15 minute drops**

0000	0100	0200	0300	0400	0500	0600	0700	0800	0900	1000	1100	1200	1300	1400	1500	1600	1700	1800	1900	2000	2100	2200	2300	
164	67	48	69	106	226	556	635	625	613	610	718	694	775	836	1212	1544	1796	1339	706	534	383	286	203	
50	17	7	15	17	38	122	159	152	147	138	157	185	187	211	216	361	436	415	201	144	92	97	54	28
70	17	13	11	28	38	128	158	178	154	160	181	187	137	223	268	367	501	390	169	162	107	76	56	36
26	18	16	24	25	65	151	150	165	154	165	191	146	289	195	370	399	423	276	156	127	80	63	51	19
18	15	12	19	36	85	155	168	130	158	147	189	176	162	207	358	417	436	258	180	101	104	50	42	18

AM Peak 1130 - 1230 (752), AM PHF=0.98 PM Peak 1700 - 1800 (1796), PM PHF=0.90

**Wednesday, January 09, 2013=14781, 15 minute drops**

0000	0100	0200	0300	0400	0500	0600	0700	0800	0900	1000	1100	1200	1300	1400	1500	1600	1700	1800	1900	2000	2100	2200	2300	
101	82	57	49	88	258	552	675	660	589	652	620	750	771	825	1187	1536	1770	1238	695	580	462	353	231	
28	27	14	10	16	31	108	178	160	146	150	160	204	210	180	242	384	398	397	197	165	132	106	59	34
36	19	18	16	16	34	135	146	168	156	174	172	166	173	212	271	376	529	345	124	149	108	96	51	34
19	22	18	14	27	87	161	177	169	110	147	168	198	200	226	324	383	418	247	228	143	122	82	74	26
18	14	7	9	29	106	148	174	163	177	181	120	182	188	207	350	393	425	249	146	123	100	69	47	31

AM Peak 1145 - 1245 (688), AM PHF=0.84 PM Peak 1700 - 1800 (1770), PM PHF=0.84

**Thursday, January 10, 2013=14901, 15 minute drops**

0000	0100	0200	0300	0400	0500	0600	0700	0800	0900	1000	1100	1200	1300	1400	1500	1600	1700	1800	1900	2000	2100	2200	2300	
125	89	65	48	94	222	551	673	545	624	594	673	779	740	940	1191	1521	1838	1299	772	575	407	317	219	
34	28	19	12	13	34	130	168	108	169	149	167	175	170	207	249	361	462	356	246	151	118	73	16	39
34	21	16	11	19	37	146	175	181	148	149	163	220	196	273	280	379	460	321	213	157	120	81	100	52
26	23	17	14	31	70	151	173	148	155	129	159	203	132	214	315	359	509	336	170	138	91	81	57	37
31	17	13	11	31	81	124	157	108	152	167	184	181	242	246	347	422	407	286	143	129	78	82	46	24

AM Peak 1145 - 1245 (782), AM PHF=0.89 PM Peak 1645 - 1745 (1853), PM PHF=0.91

# Southern Traffic Services, Inc.

## Event Counts

**Nundy Avenue east of US 41**

**Eastbound**

**Datasets:**

**Site:** [063] !C5017  
**Input A:** 2 - East bound, A hit first. - Added to totals. (1)  
**Input B:** 0 - Unused or unknown. - Excluded from totals. (0)  
**Survey Duration:** 13:15 Monday, January 07, 2013 => 11:11 Friday, January 11, 2013  
**File:** G:\DATA\2013\Private\13015\marco\Jan -11-2013 DATA\UM063 EB.eco (Plus)  
**Identifier:** Q681MXEG MC56-L5 [MC55] (c)Microcom 19Oct04  
**Algorithm:** Event Count  
**Data type:** Axle sensors - Paired (Class, Speed, Count)

**Profile:**

**Filter time:** 0:00 Tuesday, January 08, 2013 => 0:00 Friday, January 11, 2013  
**Name:** Factory default profile  
**Scheme:** Count events divided by two.  
**Units:** Non metric (ft, mi, ft/s, mph, lb, ton)  
**In profile:** Events = 3308

**Tuesday, January 08, 2013=1111, 15 minute drops**

0000	0100	0200	0300	0400	0500	0600	0700	0800	0900	1000	1100	1200	1300	1400	1500	1600	1700	1800	1900	2000	2100	2200	2300	
8	3	1	1	2	6	23	51	48	49	58	77	73	96	97	89	94	112	75	45	39	28	24	12	
2	3	1	0	1	0	5	12	14	13	9	13	22	24	18	21	30	33	19	9	11	10	4	4	1
2	0	0	0	0	1	8	6	13	14	16	24	14	23	28	23	25	28	27	13	10	5	6	2	2
2	0	0	1	1	2	6	13	9	10	14	21	25	25	29	18	21	24	15	13	10	9	6	4	1
2	0	0	0	0	3	4	20	12	12	19	19	12	24	22	27	18	27	14	10	8	4	8	2	1

AM Peak 1115 - 1215 (86), AM PHF=0.90 PM Peak 1700 - 1800 (112), PM PHF=0.85

**Wednesday, January 09, 2013=1115, 15 minute drops**

0000	0100	0200	0300	0400	0500	0600	0700	0800	0900	1000	1100	1200	1300	1400	1500	1600	1700	1800	1900	2000	2100	2200	2300	
5	4	8	0	3	6	21	38	49	45	49	60	80	85	88	94	108	118	64	55	46	45	28	16	
1	2	2	0	1	1	5	8	9	11	13	14	26	21	19	18	25	30	18	14	12	16	6	6	2
2	1	0	0	2	2	11	9	15	11	8	19	22	23	21	20	22	31	23	16	11	6	5	7	0
1	1	4	0	0	1	4	12	18	7	16	11	13	26	21	25	29	25	9	13	15	9	11	0	1
1	0	2	0	0	2	1	9	7	16	12	16	19	15	27	31	32	32	14	12	8	14	6	3	1

AM Peak 1145 - 1245 (77), AM PHF=0.74 PM Peak 1630 - 1730 (122), PM PHF=0.95

**Thursday, January 10, 2013=1082, 15 minute drops**

0000	0100	0200	0300	0400	0500	0600	0700	0800	0900	1000	1100	1200	1300	1400	1500	1600	1700	1800	1900	2000	2100	2200	2300	
4	4	3	3	6	10	18	56	50	54	60	58	84	71	89	91	93	107	61	49	41	35	25	10	
2	2	1	1	2	2	3	9	18	22	12	15	29	13	24	25	14	23	18	10	10	14	7	2	4
0	1	2	0	1	2	9	12	12	11	15	12	23	29	20	20	29	21	14	13	6	10	7	3	3
1	0	0	1	2	1	2	16	12	9	11	11	17	11	21	21	31	34	16	18	12	9	5	2	0
1	1	0	1	1	5	4	19	8	12	22	20	15	18	24	25	19	29	13	8	13	2	6	3	2

AM Peak 1145 - 1245 (89), AM PHF=0.77 PM Peak 1700 - 1800 (107), PM PHF=0.79



# Southern Traffic Services, Inc.

## Event Counts

**Nundy Avenue east of US 41**

**Westbound**

**Datasets:**

**Site:** [063] !C6545  
**Input A:** 4 - West bound, A hit first. - Added to totals. (1)  
**Input B:** 0 - Unused or unknown. - Excluded from totals. (0)  
**Survey Duration:** 7:58 Monday, January 07, 2013 => 11:10 Friday, January 11, 2013  
**File:** G:\DATA\2013\Private\13015\marco\Jan -11-2013 DATA\UM063 WB.eco (Plus)  
**Identifier:** T516ASWG MC56-L5 [MC55] (c)Microcom 19Oct04  
**Algorithm:** Event Count  
**Data type:** Axle sensors - Paired (Class, Speed, Count)

**Profile:**

**Filter time:** 0:00 Tuesday, January 08, 2013 => 0:00 Friday, January 11, 2013  
**Name:** Factory default profile  
**Scheme:** Count events divided by two.  
**Units:** Non metric (ft, mi, ft/s, mph, lb, ton)  
**In profile:** Events = 3018

**Tuesday, January 08, 2013=986, 15 minute drops**

0000	0100	0200	0300	0400	0500	0600	0700	0800	0900	1000	1100	1200	1300	1400	1500	1600	1700	1800	1900	2000	2100	2200	2300	
6	1	0	1	5	12	39	51	55	63	69	64	67	74	75	77	71	75	62	42	29	23	17	8	
1	0	0	0	1	3	11	13	15	18	13	14	20	13	17	23	19	22	26	14	7	5	2	2	1
1	0	0	0	4	3	10	10	15	19	19	20	16	21	16	14	21	20	13	8	7	8	7	1	1
1	1	0	0	0	4	7	11	7	12	19	16	12	19	20	17	18	18	10	13	8	4	6	4	1
3	0	0	1	0	2	11	17	18	14	18	14	19	21	22	23	13	15	13	7	7	6	2	1	2

AM Peak 1030 - 1130 (71), AM PHF=0.89 PM Peak 1415 - 1515 (81), PM PHF=0.88

**Wednesday, January 09, 2013=1036, 15 minute drops**

0000	0100	0200	0300	0400	0500	0600	0700	0800	0900	1000	1100	1200	1300	1400	1500	1600	1700	1800	1900	2000	2100	2200	2300	
5	3	5	1	8	15	43	46	55	44	54	57	71	80	67	82	89	77	66	49	49	31	21	18	
1	1	1	0	1	3	9	19	12	12	17	15	23	19	17	15	22	24	18	10	12	11	3	7	0
1	0	0	0	3	5	16	10	10	10	14	14	16	23	16	21	25	15	20	12	12	6	8	6	0
1	2	4	1	3	5	10	11	13	8	12	11	15	22	19	20	19	17	17	20	17	5	6	2	0
2	0	0	0	1	2	8	6	20	14	11	17	17	16	15	26	23	21	11	7	8	9	4	3	1

AM Peak 1145 - 1245 (71), AM PHF=0.77 PM Peak 1530 - 1630 (93), PM PHF=0.89

**Thursday, January 10, 2013=996, 15 minute drops**

0000	0100	0200	0300	0400	0500	0600	0700	0800	0900	1000	1100	1200	1300	1400	1500	1600	1700	1800	1900	2000	2100	2200	2300	
1	4	2	3	8	20	36	49	59	55	59	59	74	82	70	68	77	84	66	47	30	19	16	8	
0	1	0	0	3	4	9	13	25	11	15	11	19	22	13	21	10	22	20	14	8	5	4	1	2
0	0	1	2	2	6	8	13	13	16	18	12	14	15	15	11	21	22	15	12	4	4	4	1	2
0	2	0	0	1	4	9	12	11	14	10	19	23	25	25	16	27	25	15	10	9	5	3	3	0
1	1	1	1	2	6	10	11	10	14	16	17	18	20	17	20	19	15	16	11	9	5	5	3	1

AM Peak 1145 - 1245 (73), AM PHF=0.79 PM Peak 1630 - 1730 (90), PM PHF=0.83

# Southern Traffic Services, Inc.

## Event Counts

**Nundy Avenue west of US 41**

**Eastbound**

**Datasets:**

**Site:** [64] I3R  
**Input A:** 8 - East bound A>B, West bound B>A. - Added to totals. (1)  
**Input B:** 0 - Unused or unknown. - Subtracted from totals. (-1)  
**Survey Duration:** 8:01 Monday, January 28, 2013 => 11:21 Friday, February 01, 2013  
**File:** G:\DATA\2013\Private\13015\diego0128\13015\UM64.eco (Plus)  
**Identifier:** M146EVWD MC56-6 [MC55] (c)Microcom 02/03/01  
**Algorithm:** Event Count  
**Data type:** Axle sensors - Paired (Class, Speed, Count)

**Profile:**

**Filter time:** 0:00 Tuesday, January 29, 2013 => 1:00 Friday, February 01, 2013  
**Name:** Factory default profile  
**Scheme:** Count events divided by two.  
**Units:** Non metric (ft, mi, ft/s, mph, lb, ton)  
**In profile:** Events = 572

**Tuesday, January 29, 2013=188, 15 minute drops**

0000	0100	0200	0300	0400	0500	0600	0700	0800	0900	1000	1100	1200	1300	1400	1500	1600	1700	1800	1900	2000	2100	2200	2300
0	1	0	1	0	1	6	7	5	7	6	13	14	16	17	13	19	10	12	14	10	8	7	1
0	0	0	0	0	0	1	2	0	3	1	4	5	8	3	3	2	4	4	8	4	3	3	0
0	0	0	0	0	1	1	2	3	3	2	2	3	3	6	5	4	3	1	2	3	1	3	0
0	0	0	1	0	0	1	0	0	1	2	2	4	2	5	3	4	1	2	1	1	2	1	1
0	1	0	0	0	0	3	3	2	0	1	5	2	3	3	2	9	2	5	3	2	2	0	0

AM Peak 1145 - 1245 (17), AM PHF=0.85 PM Peak 1615 - 1715 (21), PM PHF=0.58

**Wednesday, January 30, 2013=205, 15 minute drops**

0000	0100	0200	0300	0400	0500	0600	0700	0800	0900	1000	1100	1200	1300	1400	1500	1600	1700	1800	1900	2000	2100	2200	2300
5	1	1	0	1	1	6	3	13	7	13	14	13	8	14	21	21	16	12	15	4	7	5	4
1	1	0	0	0	0	1	0	4	1	4	3	5	1	1	6	7	1	3	8	2	1	2	0
2	0	0	0	0	0	1	0	3	3	2	2	4	2	8	8	7	3	4	1	1	1	1	0
1	0	1	0	0	1	1	2	2	2	5	5	3	2	2	2	4	6	4	3	0	4	1	0
1	0	0	0	1	0	3	1	4	1	2	4	1	3	3	5	3	6	1	3	1	1	1	4

AM Peak 1130 - 1230 (18), AM PHF=0.90 PM Peak 1545 - 1645 (23), PM PHF=0.82

**Thursday, January 31, 2013=179, 15 minute drops**

0000	0100	0200	0300	0400	0500	0600	0700	0800	0900	1000	1100	1200	1300	1400	1500	1600	1700	1800	1900	2000	2100	2200	2300
1	0	1	1	1	2	1	4	14	11	7	9	13	15	9	20	23	11	8	11	7	4	4	2
1	0	1	0	0	0	0	0	2	5	1	2	6	3	1	7	7	2	2	5	5	0	1	1
0	0	0	0	0	0	0	3	3	2	1	2	5	6	4	10	6	1	3	5	2	1	1	0
0	0	0	0	0	1	0	0	6	2	1	1	1	3	2	0	4	7	1	0	0	1	2	0
0	0	0	1	1	1	1	1	3	2	4	4	1	3	2	3	6	1	2	1	0	2	0	1

AM Peak 0815 - 0915 (17), AM PHF=0.71 PM Peak 1600 - 1700 (23), PM PHF=0.82

# Southern Traffic Services, Inc.

## Event Counts

**Nundy Avenue west of US 41**

**Westbound**

**Datasets:**

**Site:** [64] I3R  
**Input A:** 8 - East bound A>B, West bound B>A. - Excluded from totals. (0)  
**Input B:** 0 - Unused or unknown. - Added to totals. (1)  
**Survey Duration:** 8:01 Monday, January 28, 2013 => 11:21 Friday, February 01, 2013  
**File:** G:\DATA\2013\Private\13015\diego0128\13015\UM64.eco (Plus)  
**Identifier:** M146EVWD MC56-6 [MC55] (c)Microcom 02/03/01  
**Algorithm:** Event Count  
**Data type:** Axle sensors - Paired (Class, Speed, Count)

**Profile:**

**Filter time:** 0:00 Tuesday, January 29, 2013 => 0:00 Friday, February 01, 2013  
**Name:** Factory default profile  
**Scheme:** Count events divided by two.  
**Units:** Non metric (ft, mi, ft/s, mph, lb, ton)  
**In profile:** Events = 541

**Tuesday, January 29, 2013=187, 15 minute drops**

0000	0100	0200	0300	0400	0500	0600	0700	0800	0900	1000	1100	1200	1300	1400	1500	1600	1700	1800	1900	2000	2100	2200	2300	
1	1	1	2	0	4	8	12	4	10	6	12	8	14	7	9	17	9	6	20	10	15	8	3	
0	1	0	0	0	1	1	4	0	1	1	2	5	3	2	1	5	5	2	7	4	2	3	0	1
1	0	1	0	0	0	1	6	0	5	0	6	2	3	0	2	3	2	1	3	6	3	2	1	2
0	0	0	0	0	1	4	2	2	2	1	3	0	4	1	5	4	0	2	6	0	1	2	2	0
0	0	0	2	0	2	2	0	2	2	4	1	1	4	4	1	5	2	1	4	0	9	1	0	1

AM Peak 0630 - 0730 (16), AM PHF=0.67 PM Peak 1900 - 2000 (20), PM PHF=0.71

**Wednesday, January 30, 2013=181, 15 minute drops**

0000	0100	0200	0300	0400	0500	0600	0700	0800	0900	1000	1100	1200	1300	1400	1500	1600	1700	1800	1900	2000	2100	2200	2300	
4	1	1	0	2	0	8	11	9	9	6	13	12	9	14	15	18	12	16	4	6	4	3	4	
1	0	0	0	1	0	1	5	1	2	2	4	3	1	2	1	5	2	7	3	4	0	0	0	1
2	0	0	0	0	0	2	2	0	2	1	4	2	3	4	5	7	3	2	0	1	3	2	1	0
0	1	1	0	0	0	5	3	3	4	1	2	5	3	5	5	3	4	4	0	0	1	1	2	0
1	0	0	0	1	0	0	1	5	1	2	3	2	2	3	4	3	3	3	1	1	0	0	1	0

AM Peak 0845 - 0945 (13), AM PHF=0.65 PM Peak 1530 - 1630 (21), PM PHF=0.75

**Thursday, January 31, 2013=173, 15 minute drops**

0000	0100	0200	0300	0400	0500	0600	0700	0800	0900	1000	1100	1200	1300	1400	1500	1600	1700	1800	1900	2000	2100	2200	2300	
1	1	2	1	2	3	6	10	9	9	10	11	17	13	9	15	15	10	14	6	3	1	5	0	
1	0	1	0	0	0	0	1	2	5	7	2	2	5	3	5	4	4	2	2	0	0	1	0	0
0	0	0	0	0	0	1	3	2	3	0	5	7	4	2	5	6	2	2	2	3	1	0	0	0
0	1	0	0	1	1	4	6	3	1	0	2	4	0	2	4	1	0	7	1	0	0	1	0	0
0	0	1	1	1	2	1	0	2	0	3	2	4	4	2	1	4	4	3	1	0	0	3	0	0

AM Peak 1145 - 1245 (15), AM PHF=0.54 PM Peak 1215 - 1315 (20), PM PHF=0.71



# Southern Traffic Services, Inc.

2911 Westfield Rd  
Gulf Breeze, FL 32563  
1-800-786-3374

*Traffic is our only business!*

US 41 @ Gibsonton Dr  
Tampa, FL

File Name : 13015-7 US 41 @ Gibsonton St  
Site Code : 13015-7  
Start Date : 1/9/2013  
Page No : 1

Groups Printed- Automobiles - Trucks - Buses

Start Time	US 41 Southbound				GIBSONTON DR Westbound				US 41 Northbound				ALICE AVE Eastbound				Int. Total
	Left	Thru	Right	U-Turns	Left	Thru	Right	U-Turns	Left	Thru	Right	U-Turns	Left	Thru	Right	U-Turns	
07:00 AM	22	103	1	0	35	6	52	0	4	354	48	0	2	9	2	0	638
07:15 AM	29	96	4	0	32	8	50	0	3	412	48	0	4	3	0	0	689
07:30 AM	28	125	1	0	30	5	45	0	2	426	60	0	3	3	0	0	728
07:45 AM	33	95	2	0	39	8	63	0	2	315	54	0	3	7	3	0	624
<b>Total</b>	<b>112</b>	<b>419</b>	<b>8</b>	<b>0</b>	<b>136</b>	<b>27</b>	<b>210</b>	<b>0</b>	<b>11</b>	<b>1507</b>	<b>210</b>	<b>0</b>	<b>12</b>	<b>22</b>	<b>5</b>	<b>0</b>	<b>2679</b>
08:00 AM	28	97	0	0	39	6	57	0	2	303	44	0	2	5	3	0	586
08:15 AM	32	110	3	0	37	0	41	0	3	270	38	0	1	4	0	0	539
08:30 AM	31	102	2	0	38	4	53	0	5	195	40	0	1	3	1	0	475
08:45 AM	25	95	2	0	28	4	40	0	0	189	47	0	0	0	1	0	431
<b>Total</b>	<b>116</b>	<b>404</b>	<b>7</b>	<b>0</b>	<b>142</b>	<b>14</b>	<b>191</b>	<b>0</b>	<b>10</b>	<b>957</b>	<b>169</b>	<b>0</b>	<b>4</b>	<b>12</b>	<b>5</b>	<b>0</b>	<b>2031</b>
<b>**BREAK**</b>																	
04:00 PM	68	242	2	0	63	4	26	0	2	121	61	0	3	3	3	0	598
04:15 PM	92	253	3	0	65	10	25	0	3	128	41	0	1	3	2	0	626
04:30 PM	81	310	2	0	53	5	24	0	0	121	46	0	3	7	1	0	653
04:45 PM	89	290	3	0	72	5	33	0	4	129	62	0	1	1	4	0	693
<b>Total</b>	<b>330</b>	<b>1095</b>	<b>10</b>	<b>0</b>	<b>253</b>	<b>24</b>	<b>108</b>	<b>0</b>	<b>9</b>	<b>499</b>	<b>210</b>	<b>0</b>	<b>8</b>	<b>14</b>	<b>10</b>	<b>0</b>	<b>2570</b>
05:00 PM	114	348	3	0	48	12	19	0	1	154	70	0	2	5	3	0	779
05:15 PM	100	383	5	0	53	6	19	0	3	149	67	0	1	5	0	0	791
05:30 PM	105	311	3	0	50	7	22	0	1	143	56	0	3	5	4	0	710
05:45 PM	77	327	2	0	66	3	34	0	2	107	41	0	4	3	2	0	668
<b>Total</b>	<b>396</b>	<b>1369</b>	<b>13</b>	<b>0</b>	<b>217</b>	<b>28</b>	<b>94</b>	<b>0</b>	<b>7</b>	<b>553</b>	<b>234</b>	<b>0</b>	<b>10</b>	<b>18</b>	<b>9</b>	<b>0</b>	<b>2948</b>
<b>Grand Total</b>	<b>954</b>	<b>3287</b>	<b>38</b>	<b>0</b>	<b>748</b>	<b>93</b>	<b>603</b>	<b>0</b>	<b>37</b>	<b>3516</b>	<b>823</b>	<b>0</b>	<b>34</b>	<b>66</b>	<b>29</b>	<b>0</b>	<b>10228</b>
Apprch %	22.3	76.8	0.9	0	51.8	6.4	41.8	0	0.8	80.3	18.8	0	26.4	51.2	22.5	0	
Total %	9.3	32.1	0.4	0	7.3	0.9	5.9	0	0.4	34.4	8	0	0.3	0.6	0.3	0	
Automobiles	877	3109	36	0	716	90	557	0	36	3356	783	0	34	63	25	0	9682
% Automobiles	91.9	94.6	94.7	0	95.7	96.8	92.4	0	97.3	95.4	95.1	0	100	95.5	86.2	0	94.7
Trucks	73	164	1	0	25	1	41	0	1	149	35	0	0	2	2	0	494
% Trucks	7.7	5	2.6	0	3.3	1.1	6.8	0	2.7	4.2	4.3	0	0	3	6.9	0	4.8
Buses	4	14	1	0	7	2	5	0	0	11	5	0	0	1	2	0	52
% Buses	0.4	0.4	2.6	0	0.9	2.2	0.8	0	0	0.3	0.6	0	0	1.5	6.9	0	0.5



# Southern Traffic Services, Inc.

2911 Westfield Rd  
 Gulf Breeze, FL 32563  
 1-800-786-3374

*Traffic is our only business!*

US 41 @ Gibsonton Dr  
 Tampa, FL

File Name : 13015-7 US 41 @ Gibsonton St  
 Site Code : 13015-7  
 Start Date : 1/9/2013  
 Page No : 2

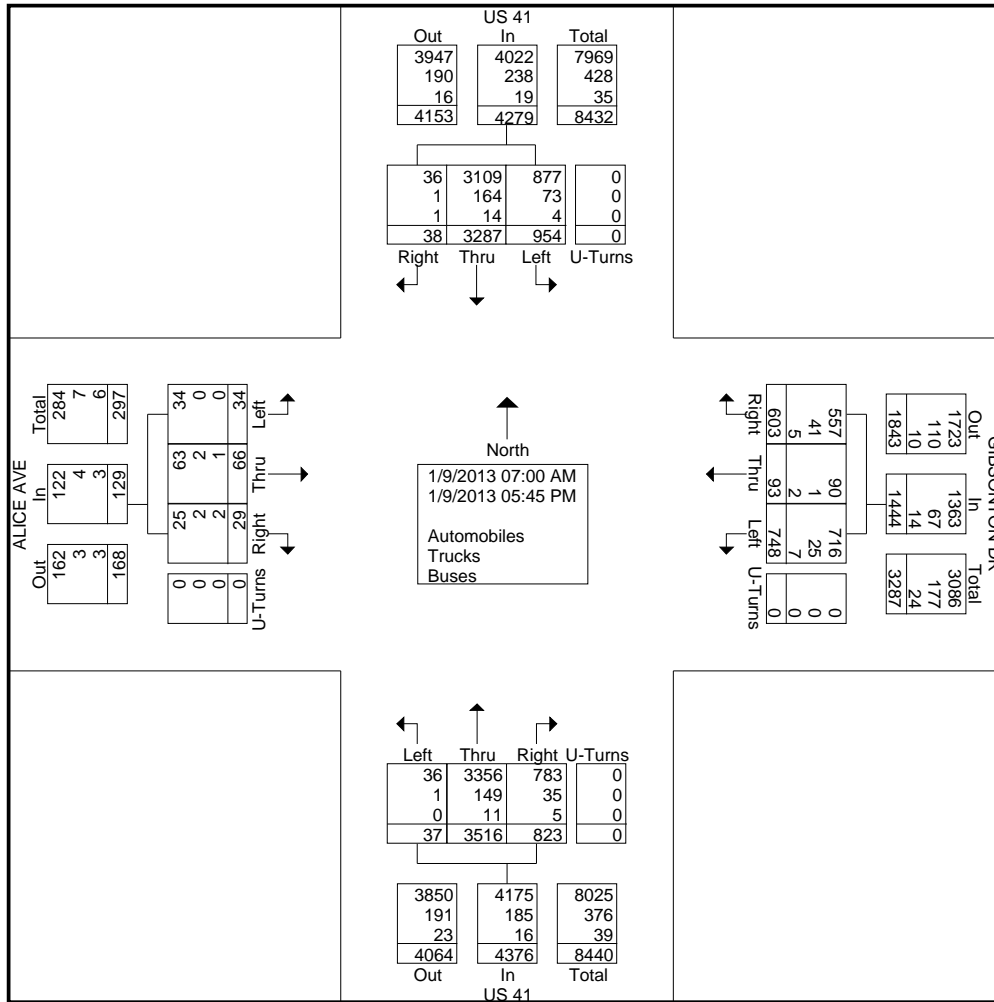



# Southern Traffic Services, Inc.

2911 Westfield Rd  
Gulf Breeze, FL 32563  
1-800-786-3374

*Traffic is our only business!*

US 41 @ Gibsonton Dr  
Tampa, FL

File Name : 13015-7 US 41 @ Gibsonton St  
Site Code : 13015-7  
Start Date : 1/9/2013  
Page No : 3

Start Time	US 41 Southbound				GIBSONTON DR Westbound				US 41 Northbound				ALICE AVE Eastbound				Int. Total				
	Thru	Right	U-Turns	App. Total	Left	Thru	Right	U-Turns	App. Total	Left	Thru	Right	U-Turns	App. Total	Left	Thru		Right	U-Turns	App. Total	
Peak Hour Analysis From 07:00 AM to 11:45 AM - Peak 1 of 1																					
Peak Hour for Entire Intersection Begins at 07:00 AM																					
07:00 AM	22	103	1	0	126	35	6	52	0	93	4	354	48	0	406	2	9	2	0	13	638
07:15 AM	29	96	4	0	129	32	8	50	0	90	3	412	48	0	463	4	3	0	0	7	689
07:30 AM	28	125	1	0	154	30	5	45	0	80	2	426	60	0	488	3	3	0	0	6	728
07:45 AM	33	95	2	0	130	39	8	63	0	110	2	315	54	0	371	3	7	3	0	13	624
Total Volume	112	419	8	0	539	136	27	210	0	373	11	1507	210	0	1728	12	22	5	0	39	2679
% App. Total	20.8	77.7	1.5	0		36.5	7.2	56.3	0		0.6	87.2	12.2	0		30.8	56.4	12.8	0		
PHF	.848	.838	.500	.000	.875	.872	.844	.833	.000	.848	.688	.884	.875	.000	.885	.750	.611	.417	.000	.750	.920
Automobiles	85	353	6	0	444	128	26	197	0	351	10	1479	199	0	1688	12	22	5	0	39	2522
% Automobiles	75.9	84.2	75.0	0	82.4	94.1	96.3	93.8	0	94.1	90.9	98.1	94.8	0	97.7	100	100	100	0	100	94.1
Trucks	27	63	1	0	91	7	1	12	0	20	1	26	9	0	36	0	0	0	0	0	147
% Trucks	24.1	15.0	12.5	0	16.9	5.1	3.7	5.7	0	5.4	9.1	1.7	4.3	0	2.1	0	0	0	0	0	5.5
Buses	0	3	1	0	4	1	0	1	0	2	0	2	2	0	4	0	0	0	0	0	10
% Buses	0	0.7	12.5	0	0.7	0.7	0	0.5	0	0.5	0	0.1	1.0	0	0.2	0	0	0	0	0	0.4

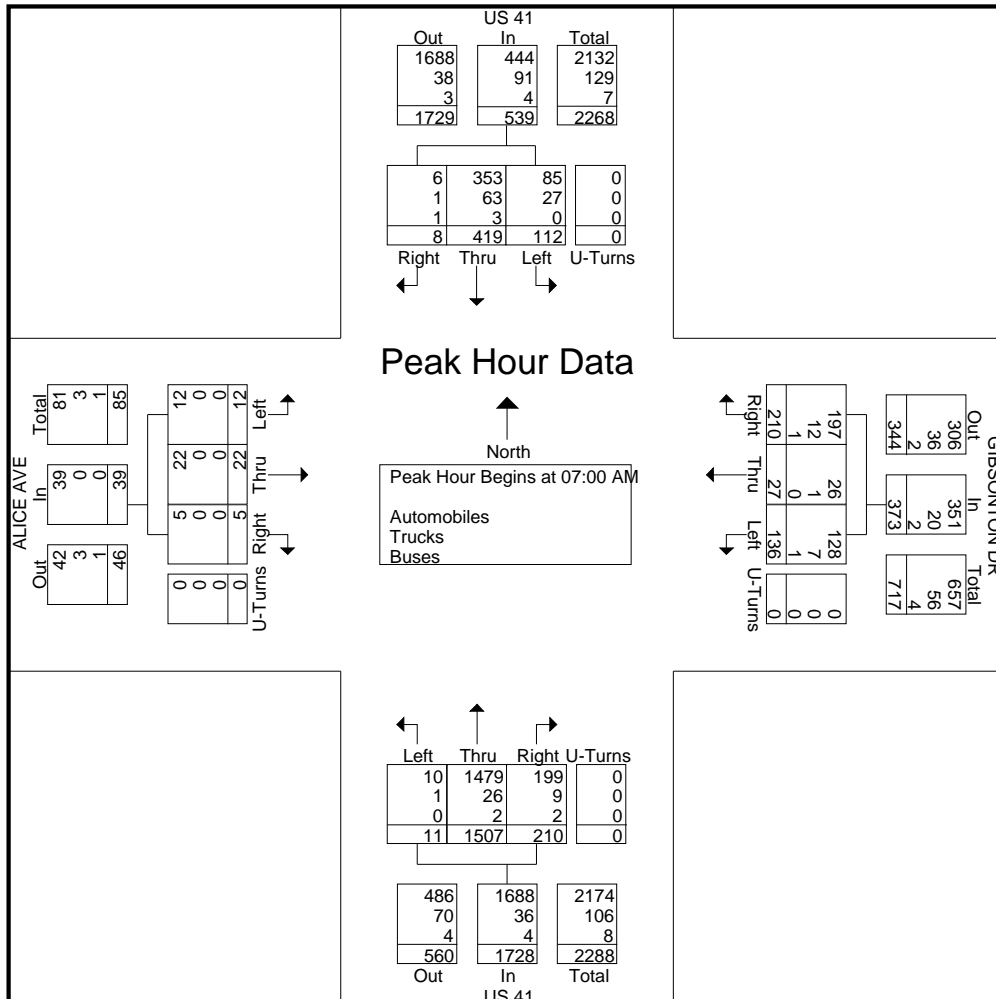



# Southern Traffic Services, Inc.

2911 Westfield Rd  
Gulf Breeze, FL 32563  
1-800-786-3374

*Traffic is our only business!*

US 41 @ Gibsonton Dr  
Tampa, FL

File Name : 13015-7 US 41 @ Gibsonton St  
Site Code : 13015-7  
Start Date : 1/9/2013  
Page No : 4

Start Time	US 41 Southbound					GIBSONTON DR Westbound					US 41 Northbound					ALICE AVE Eastbound					Int. Total
	Left	Thru	Right	U-Turns	App. Total	Left	Thru	Right	U-Turns	App. Total	Left	Thru	Right	U-Turns	App. Total	Left	Thru	Right	U-Turns	App. Total	

Peak Hour Analysis From 12:00 PM to 05:45 PM - Peak 1 of 1

Peak Hour for Entire Intersection Begins at 04:45 PM

04:45 PM	89	290	3	0	382	72	5	33	0	110	4	129	62	0	195	1	1	4	0	6	693
05:00 PM	114	348	3	0	465	48	12	19	0	79	1	154	70	0	225	2	5	3	0	10	779
05:15 PM	100	383	5	0	488	53	6	19	0	78	3	149	67	0	219	1	5	0	0	6	791
05:30 PM	105	311	3	0	419	50	7	22	0	79	1	143	56	0	200	3	5	4	0	12	710
Total Volume	408	1332	14	0	1754	223	30	93	0	346	9	575	255	0	839	7	16	11	0	34	2973
% App. Total	23.3	75.9	0.8	0		64.5	8.7	26.9	0		1.1	68.5	30.4	0		20.6	47.1	32.4	0		
PHF	.895	.869	.700	.000	.899	.774	.625	.705	.000	.786	.563	.933	.911	.000	.932	.583	.800	.688	.000	.708	.940
Automobiles	394	1308	14	0	1716	214	29	87	0	330	9	531	245	0	785	7	16	9	0	32	2863
% Automobiles	96.6	98.2	100	0	97.8	96.0	96.7	93.5	0	95.4	100	92.3	96.1	0	93.6	100	100	81.8	0	94.1	96.3
Trucks	10	21	0	0	31	5	0	6	0	11	0	40	9	0	49	0	0	0	0	0	91
% Trucks	2.5	1.6	0	0	1.8	2.2	0	6.5	0	3.2	0	7.0	3.5	0	5.8	0	0	0	0	0	3.1
Buses	4	3	0	0	7	4	1	0	0	5	0	4	1	0	5	0	0	2	0	2	19
% Buses	1.0	0.2	0	0	0.4	1.8	3.3	0	0	1.4	0	0.7	0.4	0	0.6	0	0	18.2	0	5.9	0.6

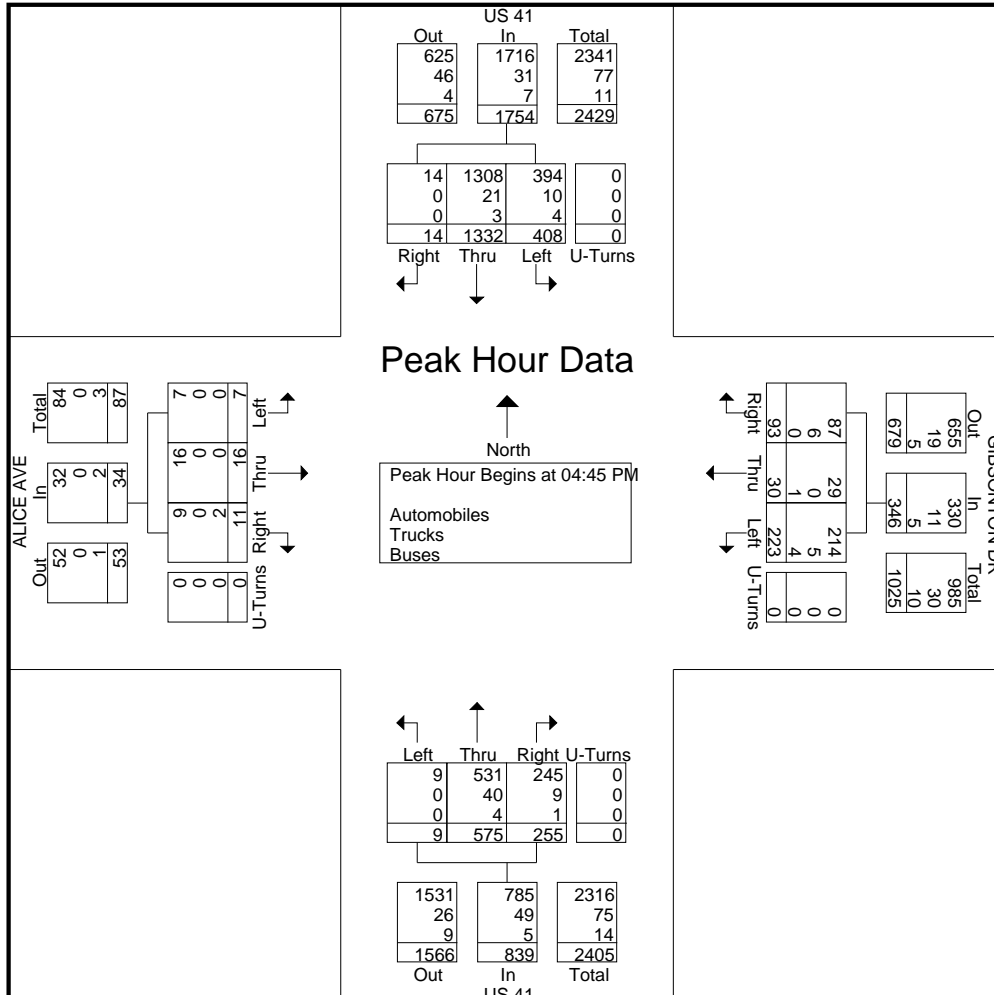



# Southern Traffic Services, Inc.

2911 Westfield Rd  
Gulf Breeze, FL 32563  
1-800-786-3374

*Traffic is our only business!*

US 41 @ Gibsonton Dr  
Tampa, FL

File Name : 13015-7 US 41 @ Gibsonton St  
Site Code : 13015-7  
Start Date : 1/9/2013  
Page No : 1

Groups Printed- Automobiles

Start Time	US 41 Southbound				GIBSONTON DR Westbound				US 41 Northbound				ALICE AVE Eastbound				Int. Total
	Left	Thru	Right	U-Turns	Left	Thru	Right	U-Turns	Left	Thru	Right	U-Turns	Left	Thru	Right	U-Turns	
07:00 AM	17	89	1	0	32	6	46	0	4	351	44	0	2	9	2	0	603
07:15 AM	22	83	3	0	30	8	49	0	3	398	47	0	4	3	0	0	650
07:30 AM	21	105	1	0	29	5	42	0	2	420	56	0	3	3	0	0	687
07:45 AM	25	76	1	0	37	7	60	0	1	310	52	0	3	7	3	0	582
Total	85	353	6	0	128	26	197	0	10	1479	199	0	12	22	5	0	2522
08:00 AM	22	82	0	0	37	5	54	0	2	290	41	0	2	3	2	0	540
08:15 AM	24	96	3	0	35	0	39	0	3	259	36	0	1	4	0	0	500
08:30 AM	24	85	2	0	37	4	46	0	5	193	37	0	1	3	1	0	438
08:45 AM	19	77	2	0	28	4	34	0	0	179	45	0	0	0	1	0	389
Total	89	340	7	0	137	13	173	0	10	921	159	0	4	10	4	0	1867
<b>**BREAK**</b>																	
04:00 PM	66	236	2	0	60	4	23	0	2	105	59	0	3	3	3	0	566
04:15 PM	89	244	3	0	63	10	24	0	3	118	38	0	1	3	2	0	598
04:30 PM	79	304	2	0	52	5	22	0	0	104	43	0	3	6	1	0	621
04:45 PM	84	286	3	0	66	5	29	0	4	119	58	0	1	1	2	0	658
Total	318	1070	10	0	241	24	98	0	9	446	198	0	8	13	8	0	2443
05:00 PM	110	340	3	0	47	11	18	0	1	141	68	0	2	5	3	0	749
05:15 PM	98	374	5	0	52	6	18	0	3	141	63	0	1	5	0	0	766
05:30 PM	102	308	3	0	49	7	22	0	1	130	56	0	3	5	4	0	690
05:45 PM	75	324	2	0	62	3	31	0	2	98	40	0	4	3	1	0	645
Total	385	1346	13	0	210	27	89	0	7	510	227	0	10	18	8	0	2850
Grand Total	877	3109	36	0	716	90	557	0	36	3356	783	0	34	63	25	0	9682
Apprch %	21.8	77.3	0.9	0	52.5	6.6	40.9	0	0.9	80.4	18.8	0	27.9	51.6	20.5	0	
Total %	9.1	32.1	0.4	0	7.4	0.9	5.8	0	0.4	34.7	8.1	0	0.4	0.7	0.3	0	





# Southern Traffic Services, Inc.

2911 Westfield Rd  
Gulf Breeze, FL 32563  
1-800-786-3374

*Traffic is our only business!*

US 41 @ Gibsonton Dr  
Tampa, FL

File Name : 13015-7 US 41 @ Gibsonton St  
Site Code : 13015-7  
Start Date : 1/9/2013  
Page No : 2

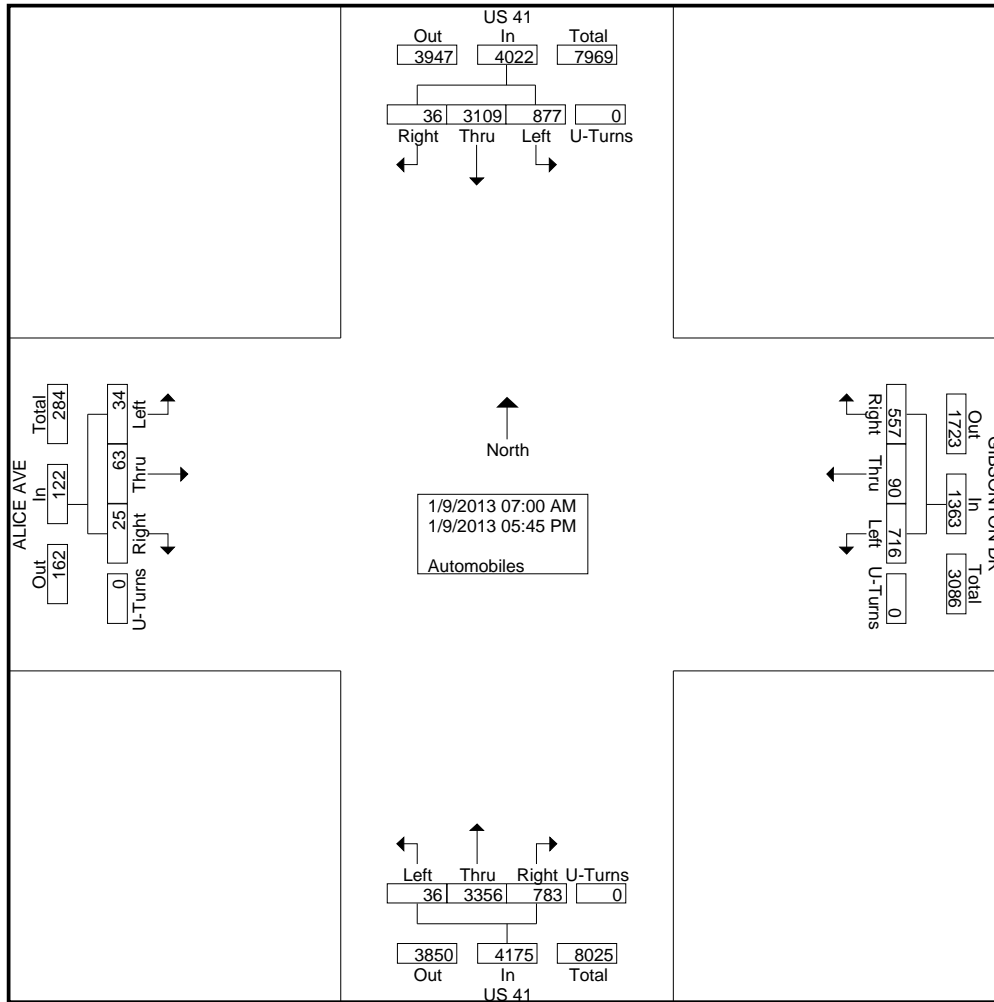



# Southern Traffic Services, Inc.

2911 Westfield Rd  
 Gulf Breeze, FL 32563  
 1-800-786-3374

*Traffic is our only business!*

US 41 @ Gibsonton Dr  
 Tampa, FL

File Name : 13015-7 US 41 @ Gibsonton St  
 Site Code : 13015-7  
 Start Date : 1/9/2013  
 Page No : 3

Start Time	US 41 Southbound				GIBSONTON DR Westbound				US 41 Northbound				ALICE AVE Eastbound				Int. Total				
	Thru	Right	U-Turns	App. Total	Left	Thru	Right	U-Turns	App. Total	Left	Thru	Right	U-Turns	App. Total	Left	Thru		Right	U-Turns	App. Total	
Peak Hour Analysis From 07:00 AM to 11:45 AM - Peak 1 of 1																					
Peak Hour for Entire Intersection Begins at 07:00 AM																					
07:00 AM	17	89	1	0	107	32	6	46	0	84	4	351	44	0	399	2	9	2	0	13	603
07:15 AM	22	83	3	0	108	30	8	49	0	87	3	398	47	0	448	4	3	0	0	7	650
07:30 AM	21	105	1	0	127	29	5	42	0	76	2	420	56	0	478	3	3	0	0	6	687
07:45 AM	25	76	1	0	102	37	7	60	0	104	1	310	52	0	363	3	7	3	0	13	582
Total Volume	85	353	6	0	444	128	26	197	0	351	10	1479	199	0	1688	12	22	5	0	39	2522
% App. Total	19.1	79.5	1.4	0		36.5	7.4	56.1	0		0.6	87.6	11.8	0		30.8	56.4	12.8	0		
PHF	.850	.840	.500	.000	.874	.865	.813	.821	.000	.844	.625	.880	.888	.000	.883	.750	.611	.417	.000	.750	.918

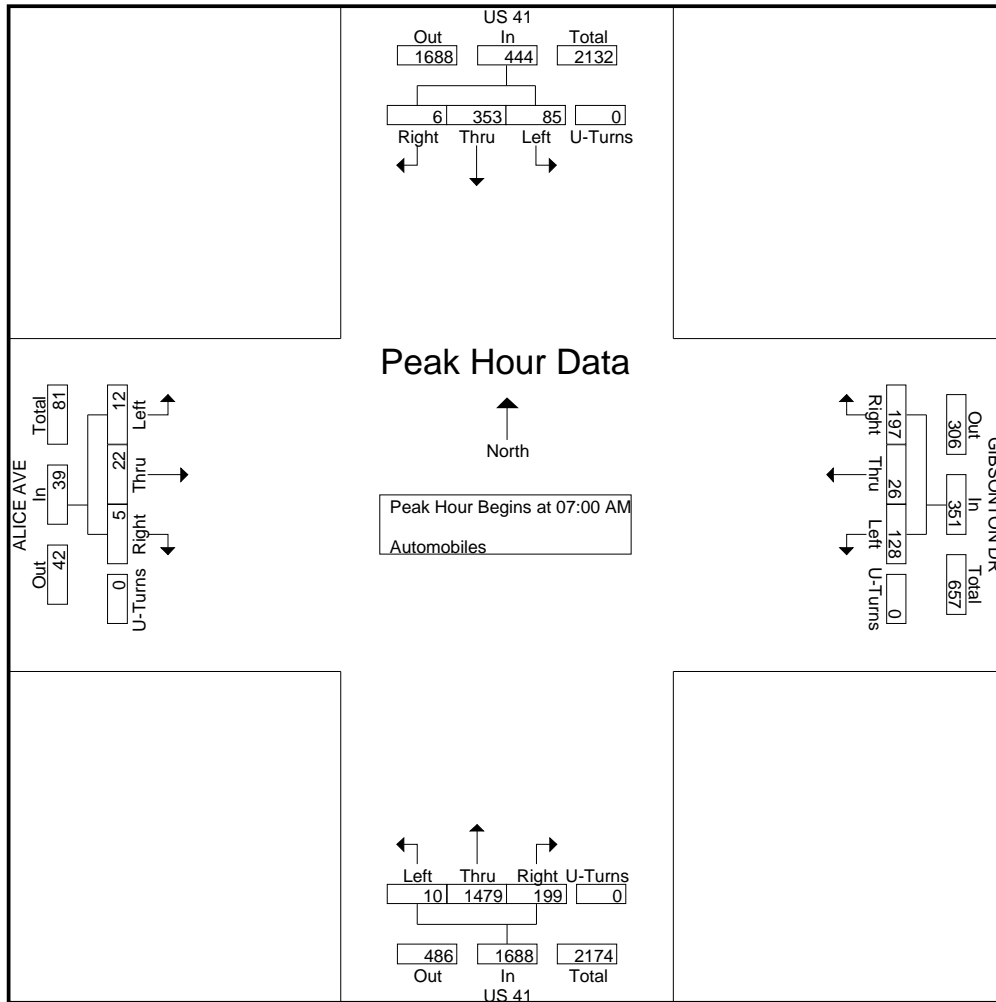



# Southern Traffic Services, Inc.

2911 Westfield Rd  
 Gulf Breeze, FL 32563  
 1-800-786-3374

*Traffic is our only business!*

US 41 @ Gibsonton Dr  
 Tampa, FL

File Name : 13015-7 US 41 @ Gibsonton St  
 Site Code : 13015-7  
 Start Date : 1/9/2013  
 Page No : 4

Start Time	US 41 Southbound					GIBSONTON DR Westbound					US 41 Northbound					ALICE AVE Eastbound					Int. Total
	Left	Thru	Right	U-Turns	App. Total	Left	Thru	Right	U-Turns	App. Total	Left	Thru	Right	U-Turns	App. Total	Left	Thru	Right	U-Turns	App. Total	
Peak Hour Analysis From 12:00 PM to 05:45 PM - Peak 1 of 1																					
Peak Hour for Entire Intersection Begins at 04:45 PM																					
04:45 PM	84	286	3	0	373	66	5	29	0	100	4	119	58	0	181	1	1	2	0	4	658
05:00 PM	110	340	3	0	453	47	11	18	0	76	1	141	68	0	210	2	5	3	0	10	749
05:15 PM	98	374	5	0	477	52	6	18	0	76	3	141	63	0	207	1	5	0	0	6	766
05:30 PM	102	308	3	0	413	49	7	22	0	78	1	130	56	0	187	3	5	4	0	12	690
Total Volume	394	1308	14	0	1716	214	29	87	0	330	9	531	245	0	785	7	16	9	0	32	2863
% App. Total	23	76.2	0.8	0		64.8	8.8	26.4	0		1.1	67.6	31.2	0		21.9	50	28.1	0		
PHF	.895	.874	.700	.000	.899	.811	.659	.750	.000	.825	.563	.941	.901	.000	.935	.583	.800	.563	.000	.667	.934

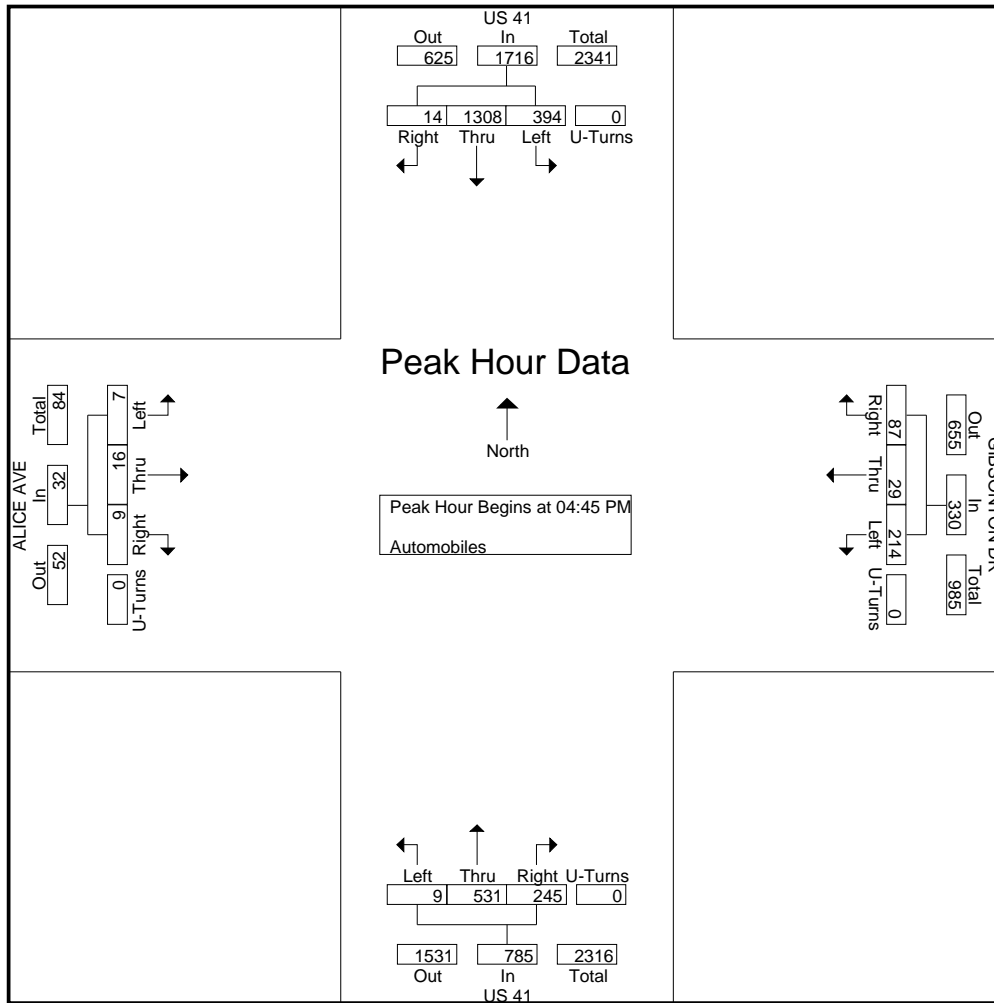



# Southern Traffic Services, Inc.

2911 Westfield Rd  
Gulf Breeze, FL 32563  
1-800-786-3374

*Traffic is our only business!*

US 41 @ Gibsonton Dr  
Tampa, FL

File Name : 13015-7 US 41 @ Gibsonton St  
Site Code : 13015-7  
Start Date : 1/9/2013  
Page No : 1

Groups Printed- Trucks - Buses

Start Time	US 41 Southbound				GIBSONTON DR Westbound				US 41 Northbound				ALICE AVE Eastbound				Int. Total	
	Left	Thru	Right	U-Turns	Left	Thru	Right	U-Turns	Left	Thru	Right	U-Turns	Left	Thru	Right	U-Turns		
07:00 AM	5	14	0	0	3	0	6	0	0	3	4	0	0	0	0	0	0	35
07:15 AM	7	13	1	0	2	0	1	0	0	14	1	0	0	0	0	0	0	39
07:30 AM	7	20	0	0	1	0	3	0	0	6	4	0	0	0	0	0	0	41
07:45 AM	8	19	1	0	2	1	3	0	1	5	2	0	0	0	0	0	0	42
Total	27	66	2	0	8	1	13	0	1	28	11	0	0	0	0	0	0	157
08:00 AM	6	15	0	0	2	1	3	0	0	13	3	0	0	2	1	0	0	46
08:15 AM	8	14	0	0	2	0	2	0	0	11	2	0	0	0	0	0	0	39
08:30 AM	7	17	0	0	1	0	7	0	0	2	3	0	0	0	0	0	0	37
08:45 AM	6	18	0	0	0	0	6	0	0	10	2	0	0	0	0	0	0	42
Total	27	64	0	0	5	1	18	0	0	36	10	0	0	2	1	0	0	164
<b>**BREAK**</b>																		
04:00 PM	2	6	0	0	3	0	3	0	0	16	2	0	0	0	0	0	0	32
04:15 PM	3	9	0	0	2	0	1	0	0	10	3	0	0	0	0	0	0	28
04:30 PM	2	6	0	0	1	0	2	0	0	17	3	0	0	1	0	0	0	32
04:45 PM	5	4	0	0	6	0	4	0	0	10	4	0	0	0	2	0	0	35
Total	12	25	0	0	12	0	10	0	0	53	12	0	0	1	2	0	0	127
05:00 PM	4	8	0	0	1	1	1	0	0	13	2	0	0	0	0	0	0	30
05:15 PM	2	9	0	0	1	0	1	0	0	8	4	0	0	0	0	0	0	25
05:30 PM	3	3	0	0	1	0	0	0	0	13	0	0	0	0	0	0	0	20
05:45 PM	2	3	0	0	4	0	3	0	0	9	1	0	0	0	1	0	0	23
Total	11	23	0	0	7	1	5	0	0	43	7	0	0	0	1	0	0	98
Grand Total	77	178	2	0	32	3	46	0	1	160	40	0	0	3	4	0	0	546
Apprch %	30	69.3	0.8	0	39.5	3.7	56.8	0	0.5	79.6	19.9	0	0	42.9	57.1	0	0	
Total %	14.1	32.6	0.4	0	5.9	0.5	8.4	0	0.2	29.3	7.3	0	0	0.5	0.7	0	0	
Trucks	73	164	1	0	25	1	41	0	1	149	35	0	0	2	2	0	0	494
% Trucks	94.8	92.1	50	0	78.1	33.3	89.1	0	100	93.1	87.5	0	0	66.7	50	0	0	90.5
Buses	4	14	1	0	7	2	5	0	0	11	5	0	0	1	2	0	0	52
% Buses	5.2	7.9	50	0	21.9	66.7	10.9	0	0	6.9	12.5	0	0	33.3	50	0	0	9.5



# Southern Traffic Services, Inc.

2911 Westfield Rd  
 Gulf Breeze, FL 32563  
 1-800-786-3374

*Traffic is our only business!*

US 41 @ Gibsonton Dr  
 Tampa, FL

File Name : 13015-7 US 41 @ Gibsonton St  
 Site Code : 13015-7  
 Start Date : 1/9/2013  
 Page No : 2

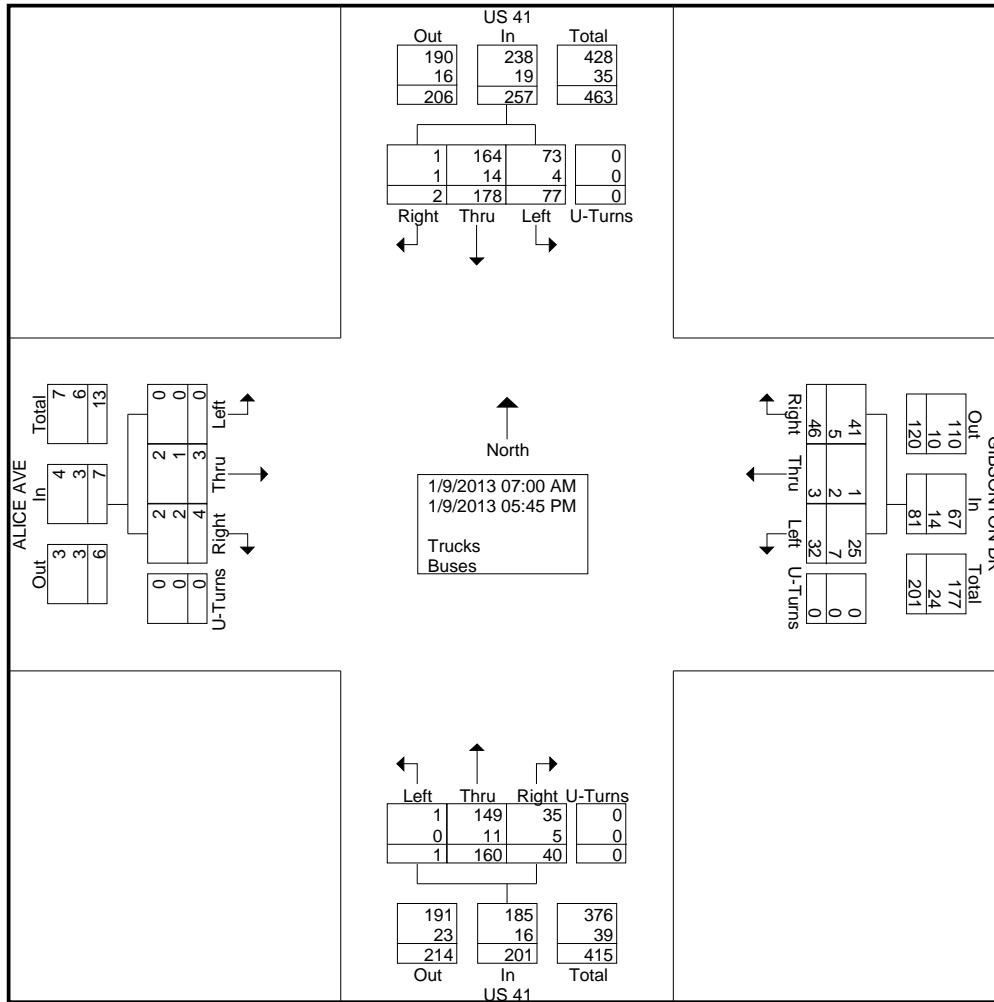



# Southern Traffic Services, Inc.

2911 Westfield Rd  
 Gulf Breeze, FL 32563  
 1-800-786-3374

*Traffic is our only business!*

US 41 @ Gibsonton Dr  
 Tampa, FL

File Name : 13015-7 US 41 @ Gibsonton St  
 Site Code : 13015-7  
 Start Date : 1/9/2013  
 Page No : 3

Start Time	US 41 Southbound				GIBSONTON DR Westbound				US 41 Northbound				ALICE AVE Eastbound				Int. Total				
	Thru	Right	U-Turns	App. Total	Left	Thru	Right	U-Turns	App. Total	Left	Thru	Right	U-Turns	App. Total	Left	Thru		Right	U-Turns	App. Total	
Peak Hour Analysis From 07:00 AM to 11:45 AM - Peak 1 of 1																					
Peak Hour for Entire Intersection Begins at 07:15 AM																					
07:15 AM	7	13	1	0	21	2	0	1	0	3	0	14	1	0	15	0	0	0	0	0	39
07:30 AM	7	20	0	0	27	1	0	3	0	4	0	6	4	0	10	0	0	0	0	0	41
07:45 AM	8	19	1	0	28	2	1	3	0	6	1	5	2	0	8	0	0	0	0	0	42
08:00 AM	6	15	0	0	21	2	1	3	0	6	0	13	3	0	16	0	2	1	0	3	46
Total Volume	28	67	2	0	97	7	2	10	0	19	1	38	10	0	49	0	2	1	0	3	168
% App. Total	28.9	69.1	2.1	0		36.8	10.5	52.6	0		2	77.6	20.4	0		0	66.7	33.3	0		
PHF	.875	.838	.500	.000	.866	.875	.500	.833	.000	.792	.250	.679	.625	.000	.766	.000	.250	.250	.000	.250	.913

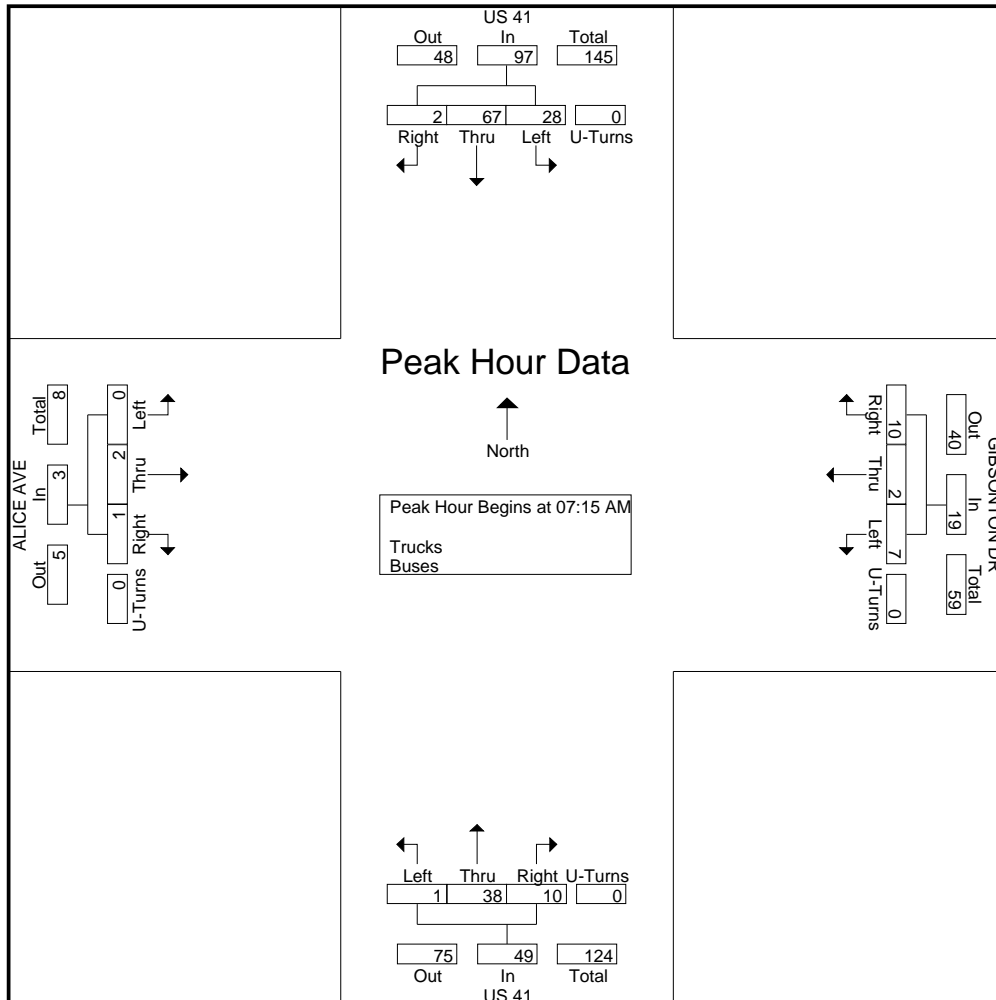



# Southern Traffic Services, Inc.

2911 Westfield Rd  
 Gulf Breeze, FL 32563  
 1-800-786-3374

*Traffic is our only business!*

US 41 @ Gibsonton Dr  
 Tampa, FL

File Name : 13015-7 US 41 @ Gibsonton St  
 Site Code : 13015-7  
 Start Date : 1/9/2013  
 Page No : 4

Start Time	US 41 Southbound					GIBSONTON DR Westbound					US 41 Northbound					ALICE AVE Eastbound					Int. Total
	Left	Thru	Right	U-Turns	App. Total	Left	Thru	Right	U-Turns	App. Total	Left	Thru	Right	U-Turns	App. Total	Left	Thru	Right	U-Turns	App. Total	
Peak Hour Analysis From 12:00 PM to 05:45 PM - Peak 1 of 1																					
Peak Hour for Entire Intersection Begins at 04:00 PM																					
04:00 PM	2	6	0	0	8	3	0	3	0	6	0	16	2	0	18	0	0	0	0	0	32
04:15 PM	3	9	0	0	12	2	0	1	0	3	0	10	3	0	13	0	0	0	0	0	28
04:30 PM	2	6	0	0	8	1	0	2	0	3	0	17	3	0	20	0	1	0	0	1	32
04:45 PM	5	4	0	0	9	6	0	4	0	10	0	10	4	0	14	0	0	2	0	2	35
Total Volume	12	25	0	0	37	12	0	10	0	22	0	53	12	0	65	0	1	2	0	3	127
% App. Total	32.4	67.6	0	0		54.5	0	45.5	0		0	81.5	18.5	0		0	33.3	66.7	0		
PHF	.600	.694	.000	.000	.771	.500	.000	.625	.000	.550	.000	.779	.750	.000	.813	.000	.250	.250	.000	.375	.907

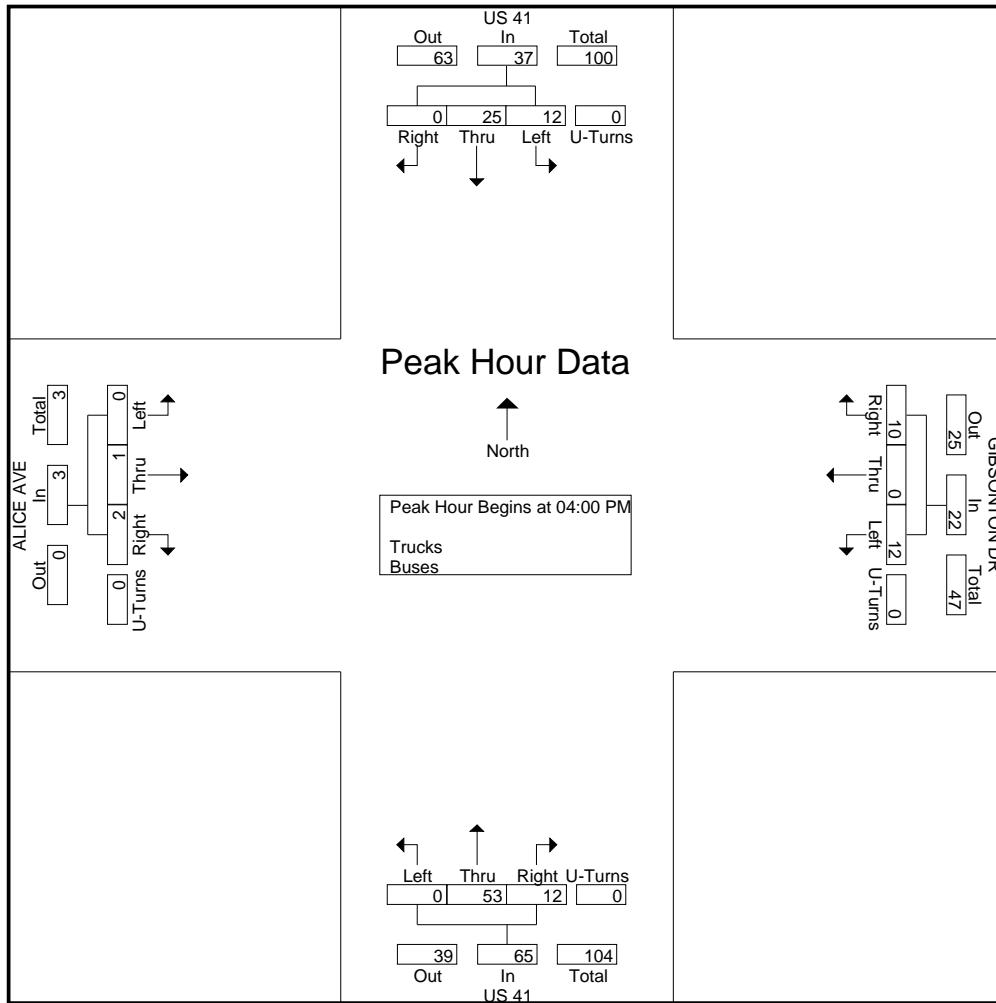



# Southern Traffic Services, Inc.

2911 Westfield Rd  
 Gulf Breeze, FL 32563  
 1-800-786-3374

*Traffic is our only business!*

US 41 @ Gibsonton Dr  
 Tampa, FL

File Name : 13015-7 US 41 @ Gibsonton St Peds  
 Site Code : 13015-7  
 Start Date : 1/9/2013  
 Page No : 1

Groups Printed- Peds

Start Time	US 41	GIBSONTON DR	US 41	ALICE AVE	Int. Total
	Southbound	Westbound	Northbound	Eastbound	
	Peds	Peds	Peds	Peds	
07:00 AM	0	0	0	0	0
07:15 AM	0	0	0	0	0
07:30 AM	0	0	0	0	0
07:45 AM	0	0	0	0	0
Total	0	0	0	0	0
08:00 AM	0	0	0	0	0
08:15 AM	0	0	0	0	0
08:30 AM	1	1	0	0	2
08:45 AM	0	0	0	0	0
Total	1	1	0	0	2
09:00 AM	0	0	0	0	0
09:15 AM	0	0	0	0	0
09:30 AM	0	0	0	0	0
09:45 AM	0	0	0	0	0
Total	0	0	0	0	0
10:00 AM	0	0	0	0	0
10:15 AM	0	0	0	0	0
10:30 AM	0	0	0	0	0
10:45 AM	0	0	0	0	0
Total	0	0	0	0	0
11:00 AM	0	0	0	0	0
11:15 AM	0	0	0	0	0
11:30 AM	0	0	0	0	0
11:45 AM	0	0	0	0	0
Total	0	0	0	0	0
12:00 PM	0	0	0	0	0
12:15 PM	0	0	0	0	0
12:30 PM	0	0	0	0	0
12:45 PM	0	0	0	0	0
Total	0	0	0	0	0
01:00 PM	0	0	0	0	0
01:15 PM	0	0	0	0	0
01:30 PM	0	0	0	0	0
01:45 PM	0	0	0	0	0
Total	0	0	0	0	0
02:00 PM	0	0	0	0	0
02:15 PM	0	0	0	0	0
02:30 PM	0	0	0	0	0
02:45 PM	0	0	0	0	0
Total	0	0	0	0	0
03:00 PM	0	0	0	0	0
03:15 PM	0	0	0	0	0
03:30 PM	0	0	0	0	0
03:45 PM	0	0	0	0	0
Total	0	0	0	0	0





# Southern Traffic Services, Inc.

2911 Westfield Rd  
 Gulf Breeze, FL 32563  
 1-800-786-3374

*Traffic is our only business!*

US 41 @ Gibsonton Dr  
 Tampa, FL

File Name : 13015-7 US 41 @ Gibsonton St Peds  
 Site Code : 13015-7  
 Start Date : 1/9/2013  
 Page No : 2

Groups Printed- Peds

Start Time	US 41 Southbound	GIBSONTON DR Westbound	US 41 Northbound	ALICE AVE Eastbound	Int. Total
	Peds	Peds	Peds	Peds	
04:00 PM	2	0	0	0	2
04:15 PM	1	0	0	0	1
04:30 PM	7	0	0	0	7
04:45 PM	1	0	0	0	1
Total	11	0	0	0	11
05:00 PM	0	0	0	0	0
05:15 PM	0	0	0	0	0
05:30 PM	0	0	0	0	0
05:45 PM	1	0	0	0	1
Total	1	0	0	0	1
Grand Total	13	1	0	0	14
Apprch %	100	100	0	0	
Total %	92.9	7.1	0	0	

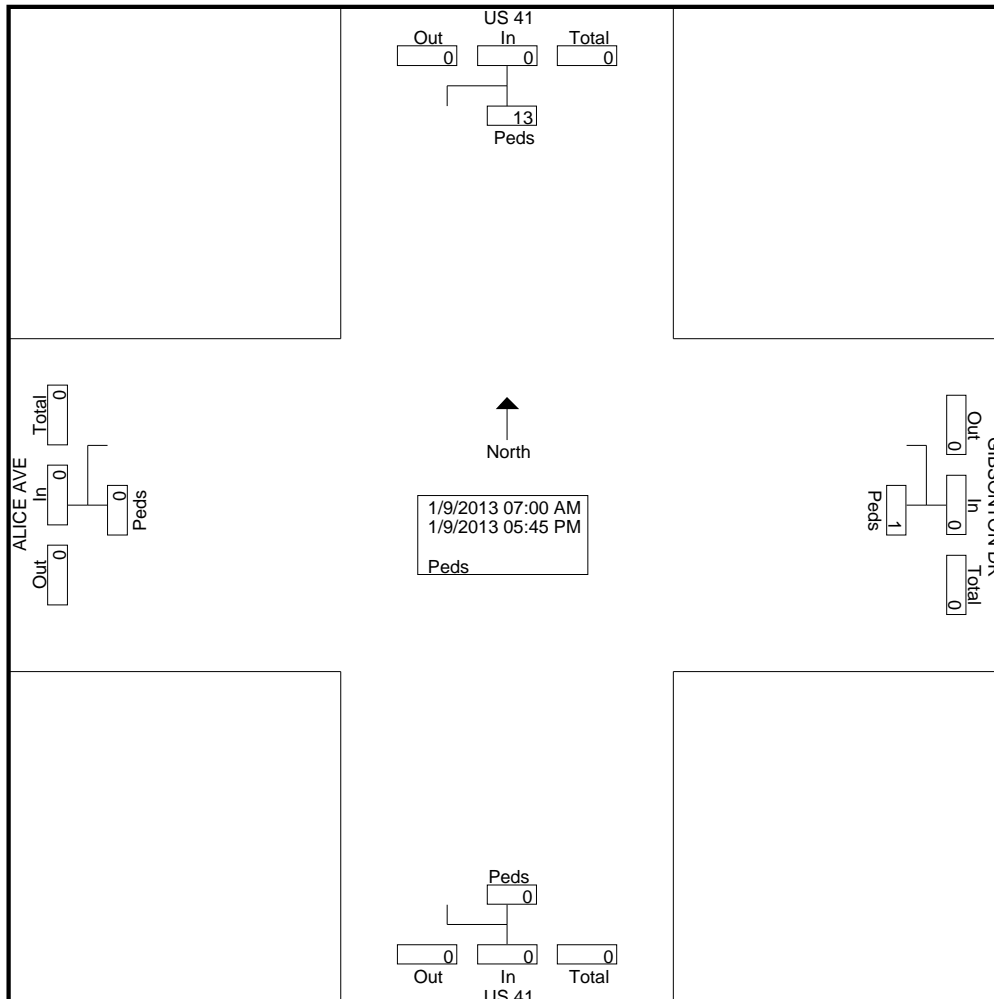

# Southern Traffic Services, Inc.

## Event Counts

**US 41 north of Gibsonton Drive**

**Northbound**

**Datasets:**

**Site:** [071] !C5100  
**Input A:** 1 - North bound, A hit first. - Added to totals. (1)  
**Input B:** 0 - Unused or unknown. - Excluded from totals. (0)  
**Survey Duration:** 14:26 Monday, January 07, 2013 => 19:44 Friday, January 11, 2013  
**File:** G:\DATA\2013\Private\13015\brandon\machine data 1-7-13\UM071 NB.eco (Plus)  
**Identifier:** Q502Y1E6 MC56-L5 [MC55] (c)Microcom 19Oct04  
**Algorithm:** Event Count  
**Data type:** Axle sensors - Paired (Class, Speed, Count)

**Profile:**

**Filter time:** 0:00 Tuesday, January 08, 2013 => 0:00 Friday, January 11, 2013  
**Name:** Factory default profile  
**Scheme:** Count events divided by two.  
**Units:** Non metric (ft, mi, ft/s, mph, lb, ton)  
**In profile:** Events = 41155

**Tuesday, January 08, 2013=13624, 15 minute drops**

0000	0100	0200	0300	0400	0500	0600	0700	0800	0900	1000	1100	1200	1300	1400	1500	1600	1700	1800	1900	2000	2100	2200	2300	
56	39	36	84	188	647	1568	1844	1225	789	713	676	727	748	707	762	664	732	492	272	222	208	135	90	
14	11	13	16	28	103	289	465	346	134	189	173	169	196	147	194	176	201	162	76	57	59	30	17	17
8	14	5	19	43	148	415	498	340	241	178	152	178	185	191	164	149	190	128	65	47	58	44	27	16
16	10	12	27	58	178	392	460	290	217	169	171	198	189	185	211	175	180	108	86	59	49	35	28	12
18	4	6	22	59	218	472	421	249	197	177	180	182	178	184	193	164	161	94	45	59	42	26	18	17

AM Peak 0645 - 0745 (1895), AM PHF=0.95 PM Peak 1500 - 1600 (762), PM PHF=0.90

**Wednesday, January 09, 2013=13774, 15 minute drops**

0000	0100	0200	0300	0400	0500	0600	0700	0800	0900	1000	1100	1200	1300	1400	1500	1600	1700	1800	1900	2000	2100	2200	2300	
62	44	45	101	197	700	1518	1790	1241	765	747	656	673	692	715	775	709	718	597	313	227	229	159	101	
17	11	10	3	28	111	278	395	367	200	195	153	167	196	198	180	187	211	155	110	52	75	48	32	21
16	10	8	36	41	145	393	475	342	198	186	174	175	172	180	177	174	153	171	99	60	68	42	26	18
12	11	15	33	69	192	437	507	289	183	167	153	163	155	172	207	175	198	124	57	62	47	36	17	9
17	12	12	29	59	252	410	413	243	184	199	176	168	169	165	211	173	156	147	47	53	39	33	26	9

AM Peak 0700 - 0800 (1790), AM PHF=0.88 PM Peak 1515 - 1615 (782), PM PHF=0.93

**Thursday, January 10, 2013=13757, 15 minute drops**

0000	0100	0200	0300	0400	0500	0600	0700	0800	0900	1000	1100	1200	1300	1400	1500	1600	1700	1800	1900	2000	2100	2200	2300	
57	47	40	70	193	645	1411	1864	1250	766	712	700	698	742	743	774	718	710	553	326	261	218	168	91	
21	6	8	12	28	104	263	487	360	193	160	162	168	182	181	164	186	194	149	88	50	64	44	31	18
18	8	10	18	37	126	386	488	376	203	210	183	164	164	174	198	180	174	165	107	66	54	44	24	17
9	17	8	24	69	195	336	429	280	196	108	186	196	218	193	229	173	177	116	66	68	51	47	22	11
9	16	14	16	59	220	426	460	234	174	234	169	170	178	195	183	179	165	123	65	77	49	33	14	15

AM Peak 0700 - 0800 (1864), AM PHF=0.95 PM Peak 1515 - 1615 (796), PM PHF=0.87

# Southern Traffic Services, Inc.

## Event Counts

**US 41 north of Gibsonton Drive**

**Southbound**

**Datasets:**

**Site:** [071] !C5100  
**Input A:** 7 - North bound A>B, South bound B>A. - Excluded from totals. (0)  
**Input B:** 0 - Unused or unknown. - Added to totals. (1)  
**Survey Duration:** 14:26 Monday, January 07, 2013 => 19:44 Friday, January 11, 2013  
**File:** G:\DATA\2013\Private\13015\brandon\machine data 1-7-13\UM071 SB.eco (Plus)  
**Identifier:** Q502Y1E6 MC56-L5 [MC55] (c)Microcom 19Oct04  
**Algorithm:** Event Count  
**Data type:** Axle sensors - Paired (Class, Speed, Count)

**Profile:**

**Filter time:** 0:00 Tuesday, January 08, 2013 => 0:00 Friday, January 11, 2013  
**Name:** Factory default profile  
**Scheme:** Count events divided by two.  
**Units:** Non metric (ft, mi, ft/s, mph, lb, ton)  
**In profile:** Events = 41506

**Tuesday, January 08, 2013=13767, 15 minute drops**

0000	0100	0200	0300	0400	0500	0600	0700	0800	0900	1000	1100	1200	1300	1400	1500	1600	1700	1800	1900	2000	2100	2200	2300	
184	89	49	78	107	190	405	560	571	525	533	645	641	675	739	1139	1501	1794	1311	683	489	374	288	197	
61	17	9	16	24	30	91	143	155	141	128	134	172	170	172	189	332	428	387	204	123	87	97	44	36
73	31	15	15	29	38	86	141	144	127	138	158	157	115	217	265	347	502	395	152	154	102	74	58	38
31	19	15	28	24	60	116	139	151	125	149	179	150	259	179	349	398	433	264	152	113	78	68	52	16
19	22	10	19	30	62	112	137	121	132	118	174	162	131	171	336	424	431	265	175	99	107	49	43	20

AM Peak 1115 - 1215 (683), AM PHF=0.95 PM Peak 1700 - 1800 (1794), PM PHF=0.89

**Wednesday, January 09, 2013=13886, 15 minute drops**

0000	0100	0200	0300	0400	0500	0600	0700	0800	0900	1000	1100	1200	1300	1400	1500	1600	1700	1800	1900	2000	2100	2200	2300	
110	96	66	55	99	215	411	590	585	539	549	604	675	643	731	1171	1462	1806	1277	654	541	434	333	240	
36	26	21	12	13	27	93	125	120	144	135	153	219	166	166	260	346	436	405	194	156	114	98	60	38
38	26	23	22	29	44	98	138	164	135	134	170	140	160	171	231	381	515	349	86	137	92	83	46	43
16	25	14	11	22	66	102	172	161	111	129	182	157	171	206	343	367	452	262	234	127	124	81	79	30
20	19	8	10	35	78	118	155	140	149	151	99	159	146	188	337	368	403	261	140	121	104	71	55	35

AM Peak 1115 - 1215 (670), AM PHF=0.76 PM Peak 1700 - 1800 (1806), PM PHF=0.88

**Thursday, January 10, 2013=13853, 15 minute drops**

0000	0100	0200	0300	0400	0500	0600	0700	0800	0900	1000	1100	1200	1300	1400	1500	1600	1700	1800	1900	2000	2100	2200	2300	
146	94	65	57	95	175	426	588	484	543	573	589	668	647	802	1128	1501	1765	1271	726	550	394	337	229	
38	30	19	18	21	31	89	149	102	173	143	128	172	148	181	230	367	422	345	222	135	98	77	14	40
43	25	11	13	17	35	121	138	160	121	124	157	169	160	210	294	359	454	307	217	155	125	90	115	47
30	25	18	13	31	50	118	171	123	125	136	146	185	93	178	284	369	484	340	156	135	92	87	53	34
35	14	17	13	26	59	98	130	99	124	170	158	142	246	233	320	406	405	279	131	125	79	83	47	27

AM Peak 1145 - 1245 (684), AM PHF=0.92 PM Peak 1645 - 1745 (1766), PM PHF=0.91

# Southern Traffic Services, Inc.

## Event Counts

**US 41 south of Gibsonton Drive**

**Northbound**

**Datasets:**

**Site:** [072] !c5087  
**Input A:** 1 - North bound, A hit first. - Added to totals. (1)  
**Input B:** 0 - Unused or unknown. - Excluded from totals. (0)  
**Survey Duration:** 14:27 Monday, January 07, 2013 => 20:39 Friday, January 11, 2013  
**File:** G:\DATA\2013\Private\13015\brandon\machine data 1-7-13\UM072 NB.eco (Plus)  
**Identifier:** Q44182B7 MC56-L5 [MC55] (c)Microcom 19Oct04  
**Algorithm:** Event Count  
**Data type:** Axle sensors - Paired (Class, Speed, Count)

**Profile:**

**Filter time:** 0:00 Tuesday, January 08, 2013 => 0:00 Friday, January 11, 2013  
**Name:** Factory default profile  
**Scheme:** Count events divided by two.  
**Units:** Non metric (ft, mi, ft/s, mph, lb, ton)  
**In profile:** Events = 42112

**Tuesday, January 08, 2013=14030, 15 minute drops**

	0000	0100	0200	0300	0400	0500	0600	0700	0800	0900	1000	1100	1200	1300	1400	1500	1600	1700	1800	1900	2000	2100	2200	2300	
	56	43	28	76	169	573	1422	1837	1191	798	721	720	765	771	796	895	783	810	538	333	245	212	140	108	
14	11	9	16	21	98	262	445	348	114	181	178	180	185	182	228	202	221	173	100	61	63	38	24	18	
11	13	3	17	41	131	362	497	332	252	187	179	184	201	212	209	176	214	139	85	59	57	41	28	16	
23	11	10	23	53	154	361	499	262	220	173	173	205	196	204	229	206	203	123	99	62	46	32	40	14	
8	8	6	20	54	190	437	396	249	212	180	190	196	189	198	229	199	172	103	49	63	46	29	16	13	

AM Peak 0645 - 0745 (1878), AM PHF=0.94 PM Peak 1500 - 1600 (895), PM PHF=0.98

**Wednesday, January 09, 2013=14057, 15 minute drops**

	0000	0100	0200	0300	0400	0500	0600	0700	0800	0900	1000	1100	1200	1300	1400	1500	1600	1700	1800	1900	2000	2100	2200	2300	
	61	42	46	82	175	612	1337	1784	1192	779	771	698	695	768	788	861	788	849	610	355	260	237	158	109	
18	12	11	4	23	99	244	404	363	197	212	171	163	213	209	199	209	252	151	120	59	81	45	29	20	
16	12	11	31	40	130	334	473	314	204	188	186	173	194	189	193	191	215	160	85	75	65	45	29	10	
14	10	12	29	57	165	404	501	266	202	185	163	188	185	204	238	188	222	149	85	64	51	32	24	11	
13	8	12	18	55	218	355	406	249	176	186	178	171	176	186	231	200	160	150	65	62	40	36	27	10	

AM Peak 0700 - 0800 (1784), AM PHF=0.89 PM Peak 1645 - 1745 (889), PM PHF=0.88

**Thursday, January 10, 2013=14025, 15 minute drops**

	0000	0100	0200	0300	0400	0500	0600	0700	0800	0900	1000	1100	1200	1300	1400	1500	1600	1700	1800	1900	2000	2100	2200	2300	
	51	46	41	63	168	580	1265	1824	1188	779	746	741	722	787	808	881	792	767	618	342	305	240	163	108	
20	9	8	11	20	93	230	484	364	200	168	176	177	194	186	182	191	226	177	85	68	69	40	33	10	
10	7	9	18	33	109	339	464	355	195	222	188	174	179	181	228	190	191	167	109	74	59	42	29	21	
11	18	11	22	60	166	309	427	247	200	96	195	201	214	231	261	198	183	130	79	76	51	42	29	12	
10	12	13	12	55	212	387	449	222	184	260	182	170	200	210	210	213	167	144	69	87	61	39	17	13	

AM Peak 0700 - 0800 (1824), AM PHF=0.94 PM Peak 1515 - 1615 (890), PM PHF=0.85

# Southern Traffic Services, Inc.

## Event Counts

**US 41 south of Gibsonton Drive**

**Southbound**

**Datasets:**

**Site:** [072] !C1130  
**Input A:** 3 - South bound, A hit first. - Added to totals. (1)  
**Input B:** 0 - Unused or unknown. - Excluded from totals. (0)  
**Survey Duration:** 14:23 Monday, January 07, 2013 => 20:38 Friday, January 11, 2013  
**File:** G:\DATA\2013\Private\13015\brandon\machine data 1-7-13\UM072 SB.eco (Plus)  
**Identifier:** DB107KDD MC56-L5 [MC55] (c)Microcom 19Oct04  
**Algorithm:** Event Count  
**Data type:** Axle sensors - Paired (Class, Speed, Count)

**Profile:**

**Filter time:** 0:00 Tuesday, January 08, 2013 => 0:00 Friday, January 11, 2013  
**Name:** Factory default profile  
**Scheme:** Count events divided by two.  
**Units:** Non metric (ft, mi, ft/s, mph, lb, ton)  
**In profile:** Events = 42024

**Tuesday, January 08, 2013=13997, 15 minute drops**

0000	0100	0200	0300	0400	0500	0600	0700	0800	0900	1000	1100	1200	1300	1400	1500	1600	1700	1800	1900	2000	2100	2200	2300	
170	69	47	66	100	213	519	601	586	571	559	671	665	718	772	1141	1517	1742	1262	660	498	371	286	193	
50	18	8	15	18	30	116	147	142	140	123	150	178	176	173	199	367	411	387	185	132	95	96	50	29
74	16	11	13	24	40	123	151	156	142	152	170	166	118	234	276	345	494	364	168	152	89	79	52	33
26	18	18	22	26	66	140	142	163	139	152	177	151	266	185	331	387	429	268	145	111	90	60	53	17
20	17	10	16	32	77	140	161	125	150	132	174	170	158	180	335	418	408	243	162	103	97	51	38	19

AM Peak 1115 - 1215 (699), AM PHF=0.98 PM Peak 1645 - 1745 (1752), PM PHF=0.89

**Wednesday, January 09, 2013=14005, 15 minute drops**

0000	0100	0200	0300	0400	0500	0600	0700	0800	0900	1000	1100	1200	1300	1400	1500	1600	1700	1800	1900	2000	2100	2200	2300	
98	72	61	52	83	242	521	642	633	547	603	592	702	692	790	1125	1447	1726	1196	652	538	432	341	218	
29	25	17	8	11	32	100	152	144	132	142	145	201	185	182	232	349	409	397	180	150	116	96	54	36
33	16	18	19	19	33	130	146	170	137	154	172	149	158	196	252	359	484	322	112	132	103	90	47	34
17	19	16	14	19	76	151	179	173	121	145	168	174	174	207	321	366	420	245	217	130	117	86	74	26
19	12	10	11	34	101	140	165	146	157	162	107	178	175	205	320	373	413	232	143	126	96	69	43	30

AM Peak 0730 - 0830 (658), AM PHF=0.92 PM Peak 1700 - 1800 (1726), PM PHF=0.89

**Thursday, January 10, 2013=14022, 15 minute drops**

0000	0100	0200	0300	0400	0500	0600	0700	0800	0900	1000	1100	1200	1300	1400	1500	1600	1700	1800	1900	2000	2100	2200	2300	
126	85	63	48	87	208	518	616	535	574	590	609	714	681	875	1131	1435	1739	1219	730	541	379	309	210	
36	27	18	12	12	32	110	151	106	167	139	146	173	159	193	237	348	425	342	231	138	108	72	16	39
34	20	13	11	17	33	148	170	183	126	142	154	200	180	252	272	355	433	296	202	149	114	82	97	46
26	21	19	13	27	62	150	163	144	144	144	153	188	112	187	289	338	469	301	161	133	88	79	55	36
30	17	13	12	31	81	110	132	102	137	165	156	153	230	243	333	394	412	280	136	121	69	76	42	24

AM Peak 1145 - 1245 (717), AM PHF=0.90 PM Peak 1700 - 1800 (1739), PM PHF=0.93

# Southern Traffic Services, Inc.

## Event Counts

**Gibsonton Drive east of US 41** **Eastbound**  
This site was set east of the railroad tracks and Indiana Street

**Datasets:**

**Site:** [073] !C6502  
**Input A:** 2 - East bound, A hit first. - Added to totals. (1)  
**Input B:** 0 - Unused or unknown. - Excluded from totals. (0)  
**Survey Duration:** 14:23 Monday, January 07, 2013 => 20:53 Friday, January 11, 2013  
**File:** G:\DATA\2013\Private\13015\brandon\machine data 1-7-13\UM073 EB.eco (Plus)  
**Identifier:** T584MXCX MC56-L5 [MC55] (c)Microcom 19Oct04  
**Algorithm:** Event Count  
**Data type:** Axle sensors - Paired (Class, Speed, Count)

**Profile:**

**Filter time:** 0:00 Tuesday, January 08, 2013 => 0:00 Friday, January 11, 2013  
**Name:** Factory default profile  
**Scheme:** Count events divided by two.  
**Units:** Non metric (ft, mi, ft/s, mph, lb, ton)  
**In profile:** Events = 19587

**Tuesday, January 08, 2013=6399, 15 minute drops**

0000	0100	0200	0300	0400	0500	0600	0700	0800	0900	1000	1100	1200	1300	1400	1500	1600	1700	1800	1900	2000	2100	2200	2300	
61	47	21	32	59	95	194	336	334	312	337	342	397	400	418	550	601	611	462	294	168	148	96	84	
21	4	4	6	19	22	37	74	93	78	98	92	96	95	112	119	146	154	132	84	42	34	29	20	17
18	20	8	8	15	18	39	78	86	58	70	79	90	92	104	120	128	168	129	68	42	53	28	26	13
14	10	7	14	14	31	53	103	76	89	88	84	105	117	98	171	149	143	107	75	41	32	30	22	7
8	13	2	4	11	24	65	81	79	87	81	87	106	96	104	140	178	146	94	67	43	29	9	16	6

AM Peak 1145 - 1245 (378), AM PHF=0.90 PM Peak 1630 - 1730 (649), PM PHF=0.91

**Wednesday, January 09, 2013=6658, 15 minute drops**

0000	0100	0200	0300	0400	0500	0600	0700	0800	0900	1000	1100	1200	1300	1400	1500	1600	1700	1800	1900	2000	2100	2200	2300	
43	43	42	24	66	94	202	364	338	352	327	407	392	398	403	581	573	693	471	298	218	138	104	87	
17	5	15	6	9	12	48	81	79	90	92	100	111	107	92	129	139	189	112	100	67	35	36	20	18
13	13	14	5	20	33	45	91	91	94	78	100	97	104	96	122	152	177	119	40	65	35	22	20	17
7	15	9	9	16	25	61	93	79	87	77	111	80	99	103	174	129	183	126	97	37	40	25	26	11
6	10	4	4	21	24	48	99	89	81	80	96	104	88	112	156	153	144	114	61	49	28	21	21	9

AM Peak 1115 - 1215 (418), AM PHF=0.94 PM Peak 1645 - 1745 (702), PM PHF=0.93

**Thursday, January 10, 2013=6530, 15 minute drops**

0000	0100	0200	0300	0400	0500	0600	0700	0800	0900	1000	1100	1200	1300	1400	1500	1600	1700	1800	1900	2000	2100	2200	2300	
55	34	34	30	55	93	191	345	322	319	353	415	371	433	424	549	609	573	453	272	209	181	129	81	
18	10	8	11	15	15	31	95	96	83	84	86	106	89	99	111	149	156	118	77	57	42	34	13	11
17	10	4	11	12	20	58	71	88	79	78	122	74	98	87	143	134	150	112	83	51	57	29	33	18
11	11	13	4	17	26	39	79	65	73	87	94	108	103	108	144	154	136	120	58	45	34	37	18	10
9	3	9	4	11	32	63	100	73	84	104	113	83	143	130	151	172	131	103	54	56	48	29	17	11

AM Peak 1115 - 1215 (435), AM PHF=0.89 PM Peak 1630 - 1730 (632), PM PHF=0.92

# Southern Traffic Services, Inc.

## Event Counts

**Gibsonton Drive east of US 41** **Westbound**  
This site was set east of the railroad tracks and Indiana Street

**Datasets:**

**Site:** [073] !C.XM  
**Input A:** 4 - West bound, A hit first. - Added to totals. (1)  
**Input B:** 0 - Unused or unknown. - Excluded from totals. (0)  
**Survey Duration:** 14:28 Monday, January 07, 2013 => 20:54 Friday, January 11, 2013  
**File:** G:\DATA\2013\Private\13015\brandon\machine data 1-7-13\UM073 WB.eco (Plus)  
**Identifier:** E436839Y MC56-L5 [MC55] (c)Microcom 19Oct04  
**Algorithm:** Event Count  
**Data type:** Axle sensors - Paired (Class, Speed, Count)

**Profile:**

**Filter time:** 0:00 Tuesday, January 08, 2013 => 0:00 Friday, January 11, 2013  
**Name:** Factory default profile  
**Scheme:** Count events divided by two.  
**Units:** Non metric (ft, mi, ft/s, mph, lb, ton)  
**In profile:** Events = 18920

**Tuesday, January 08, 2013=6139, 15 minute drops**

0000	0100	0200	0300	0400	0500	0600	0700	0800	0900	1000	1100	1200	1300	1400	1500	1600	1700	1800	1900	2000	2100	2200	2300	
46	19	30	21	69	209	569	555	439	312	365	328	374	403	353	375	308	350	343	216	154	148	94	59	
15	5	8	3	16	25	115	129	116	90	94	95	86	106	87	95	62	102	91	47	47	45	24	18	9
9	6	4	5	13	34	163	128	132	75	85	68	107	91	86	82	94	87	97	56	23	36	30	19	10
5	5	12	9	20	67	139	130	102	79	86	88	80	108	85	98	53	76	85	60	44	43	28	13	6
17	3	6	4	20	83	152	168	89	68	100	77	101	98	95	100	99	85	70	53	40	24	12	9	7

AM Peak 0615 - 0715 (583), AM PHF=0.89 PM Peak 1245 - 1345 (406), PM PHF=0.94

**Wednesday, January 09, 2013=6518, 15 minute drops**

0000	0100	0200	0300	0400	0500	0600	0700	0800	0900	1000	1100	1200	1300	1400	1500	1600	1700	1800	1900	2000	2100	2200	2300	
32	22	28	50	61	245	620	596	487	332	361	363	392	309	364	429	386	339	346	269	188	141	108	50	
9	3	7	0	6	31	118	149	120	85	79	94	103	82	99	100	89	63	87	79	46	36	46	12	15
10	5	3	9	10	50	158	143	130	90	90	88	91	72	89	120	99	78	102	79	45	50	25	16	16
6	7	12	19	22	72	164	137	129	80	97	101	91	68	92	97	86	88	74	60	51	31	22	11	9
7	7	6	22	23	92	180	167	108	77	95	80	107	87	84	112	112	110	83	51	46	24	15	11	3

AM Peak 0615 - 0715 (651), AM PHF=0.90 PM Peak 1500 - 1600 (429), PM PHF=0.89

**Thursday, January 10, 2013=6263, 15 minute drops**

0000	0100	0200	0300	0400	0500	0600	0700	0800	0900	1000	1100	1200	1300	1400	1500	1600	1700	1800	1900	2000	2100	2200	2300	
43	29	19	25	69	209	563	514	455	352	334	386	405	361	404	346	365	371	298	233	188	142	107	45	
15	8	4	7	9	30	119	99	118	75	65	105	94	85	114	68	99	86	67	74	42	44	33	16	18
16	4	6	5	19	40	148	135	124	98	91	96	86	67	91	93	89	100	82	68	47	43	25	10	12
9	5	6	7	22	70	134	144	125	88	84	95	108	126	96	96	80	92	76	43	48	28	36	10	13
3	12	3	6	19	69	162	136	88	91	94	90	117	83	103	89	97	93	73	48	51	27	13	9	5

AM Peak 0600 - 0700 (563), AM PHF=0.87 PM Peak 1330 - 1430 (414), PM PHF=0.82

# Southern Traffic Services, Inc.

## Event Counts

**Alice Avenue west of US 41**

**Eastbound**

**Datasets:**

**Site:** [074] !c9014  
**Input A:** 2 - East bound, A hit first. - Added to totals. (1)  
**Input B:** 0 - Unused or unknown. - Excluded from totals. (0)  
**Survey Duration:** 14:28 Monday, January 07, 2013 => 20:51 Friday, January 11, 2013  
**File:** G:\DATA\2013\Private\13015\brandon\machine data 1-7-13\UM074 EB.eco (Plus)  
**Identifier:** AQ56F5EY MC56-L5 [MC55] (c)Microcom 19Oct04  
**Algorithm:** Event Count  
**Data type:** Axle sensors - Paired (Class, Speed, Count)

**Profile:**

**Filter time:** 0:00 Tuesday, January 08, 2013 => 0:00 Friday, January 11, 2013  
**Name:** Factory default profile  
**Scheme:** Count events divided by two.  
**Units:** Non metric (ft, mi, ft/s, mph, lb, ton)  
**In profile:** Events = 1610

**Tuesday, January 08, 2013=530, 15 minute drops**

0000	0100	0200	0300	0400	0500	0600	0700	0800	0900	1000	1100	1200	1300	1400	1500	1600	1700	1800	1900	2000	2100	2200	2300	
5	1	1	1	3	10	32	47	23	22	25	18	27	28	25	38	38	42	46	42	24	16	7	9	
1	1	0	0	3	3	5	9	8	2	8	7	8	7	5	8	14	11	8	12	8	4	1	1	1
2	0	0	0	0	1	8	10	4	6	5	3	9	5	8	4	9	14	16	10	7	5	3	3	3
0	0	1	0	0	2	6	12	5	9	8	3	6	6	4	13	8	7	6	8	4	3	1	3	2
2	0	0	1	0	4	13	16	6	5	4	5	4	10	8	13	7	10	16	12	5	4	2	2	0

AM Peak 0700 - 0800 (47), AM PHF=0.73 PM Peak 1815 - 1915 (50), PM PHF=0.78

**Wednesday, January 09, 2013=540, 15 minute drops**

0000	0100	0200	0300	0400	0500	0600	0700	0800	0900	1000	1100	1200	1300	1400	1500	1600	1700	1800	1900	2000	2100	2200	2300	
6	3	1	1	3	9	27	41	22	19	25	32	34	27	23	39	36	41	47	37	22	21	11	13	
1	0	0	0	1	2	4	10	7	4	9	10	6	7	6	9	9	9	12	14	5	10	3	2	0
3	0	0	0	1	1	3	12	7	4	4	8	6	3	7	7	9	8	13	9	3	3	4	3	0
2	2	1	1	1	2	12	10	6	9	5	8	13	8	3	9	8	15	11	6	7	6	1	4	2
0	1	0	0	0	4	8	9	2	2	7	6	9	9	7	14	10	9	11	8	7	2	3	4	1

AM Peak 0630 - 0730 (42), AM PHF=0.88 PM Peak 1730 - 1830 (49), PM PHF=0.82

**Thursday, January 10, 2013=540, 15 minute drops**

0000	0100	0200	0300	0400	0500	0600	0700	0800	0900	1000	1100	1200	1300	1400	1500	1600	1700	1800	1900	2000	2100	2200	2300	
3	5	1	1	3	7	29	51	26	25	22	22	28	31	41	26	54	49	42	27	19	13	10	5	
0	3	0	0	0	2	4	11	10	6	9	5	8	6	7	5	14	6	11	9	4	4	4	1	1
0	2	1	0	0	0	6	10	6	5	3	6	6	2	15	6	15	13	11	9	9	6	2	0	0
2	0	0	0	1	2	7	10	3	8	5	6	9	10	7	8	12	17	9	6	4	2	3	2	1
1	0	0	1	2	3	12	20	7	6	5	5	5	13	12	7	13	13	11	3	2	1	1	0	0

AM Peak 0700 - 0800 (51), AM PHF=0.64 PM Peak 1600 - 1700 (54), PM PHF=0.90



# Southern Traffic Services, Inc.

## Event Counts

**Alice Avenue west of US 41**

**Westbound**

**Datasets:**

**Site:** [074] IMA. 2XAH  
**Input A:** 4 - West bound, A hit first. - Added to totals. (1)  
**Input B:** 0 - Unused or unknown. - Excluded from totals. (0)  
**Survey Duration:** 14:27 Monday, January 07, 2013 => 20:52 Friday, January 11, 2013  
**File:** G:\DATA\2013\Private\13015\brandon\machine data 1-7-13\UM074 WB.eco (Base)  
**Identifier:** K1851VFD MC56-6 [MC55] (c)Microcom 02/03/01  
**Algorithm:** Event Count  
**Data type:** Axle sensors - Paired (Class, Speed, Count)

**Profile:**

**Filter time:** 0:00 Tuesday, January 08, 2013 => 0:00 Friday, January 11, 2013  
**Name:** Factory default profile  
**Scheme:** Count events divided by two.  
**Units:** Non metric (ft, mi, ft/s, mph, lb, ton)  
**In profile:** Events = 1824

**Tuesday, January 08, 2013=591, 15 minute drops**

0000	0100	0200	0300	0400	0500	0600	0700	0800	0900	1000	1100	1200	1300	1400	1500	1600	1700	1800	1900	2000	2100	2200	2300	
5	1	1	0	3	10	35	54	28	27	32	19	23	30	27	47	44	51	48	53	21	17	6	9	
1	1	0	0	3	3	5	9	12	4	10	7	6	8	5	10	14	14	11	13	6	5	1	1	0
2	0	0	0	0	1	10	14	4	7	3	3	9	5	9	5	8	19	12	10	6	5	3	3	3
0	0	1	0	0	2	6	14	6	12	15	4	6	6	4	16	12	7	6	7	4	3	1	3	2
2	0	0	0	0	4	14	17	6	4	5	2	11	9	16	10	11	19	23	5	4	1	2	0	

AM Peak 0715 - 0815 (57), AM PHF=0.84 PM Peak 1630 - 1730 (55), PM PHF=0.72

**Wednesday, January 09, 2013=626, 15 minute drops**

0000	0100	0200	0300	0400	0500	0600	0700	0800	0900	1000	1100	1200	1300	1400	1500	1600	1700	1800	1900	2000	2100	2200	2300	
5	3	1	1	3	11	32	50	33	20	32	33	34	27	25	45	48	50	56	43	24	25	11	14	
0	0	0	0	1	2	4	11	12	6	12	10	5	6	7	10	10	8	15	16	6	11	3	3	0
3	0	0	0	1	3	5	15	8	4	5	7	5	4	8	9	17	11	15	11	3	3	5	3	0
2	2	1	1	1	2	14	11	8	8	5	10	13	8	3	12	10	20	12	6	8	7	1	4	2
0	1	0	0	0	4	9	13	5	2	10	6	11	9	7	14	11	11	14	10	7	4	2	4	1

AM Peak 0715 - 0815 (51), AM PHF=0.85 PM Peak 1730 - 1830 (61), PM PHF=0.76

**Thursday, January 10, 2013=607, 15 minute drops**

0000	0100	0200	0300	0400	0500	0600	0700	0800	0900	1000	1100	1200	1300	1400	1500	1600	1700	1800	1900	2000	2100	2200	2300	
3	5	1	1	3	7	32	57	30	27	23	29	34	33	45	33	54	59	52	27	20	14	13	5	
0	3	0	0	0	2	4	14	12	4	9	6	10	8	7	5	15	7	12	9	4	5	6	1	1
0	2	1	0	0	0	8	11	6	4	3	9	6	3	18	10	16	16	13	9	10	6	2	1	
2	0	0	0	1	2	7	10	4	12	6	8	12	9	7	9	12	21	10	6	4	2	4	2	1
1	0	0	1	2	3	13	22	8	7	5	6	6	13	13	9	11	15	17	3	2	1	1	0	0

AM Peak 0700 - 0800 (57), AM PHF=0.65 PM Peak 1715 - 1815 (64), PM PHF=0.76



# Southern Traffic Services, Inc.

2911 Westfield Rd  
Gulf Breeze, FL 32563  
1-800-786-3374

*Traffic is our only business!*

US 41 @ Riverview Dr  
Tampa, FL

File Name : 13015-8 US 41 @ RIVERVIEW DR  
Site Code : 13015-8  
Start Date : 1/10/2013  
Page No : 1

Groups Printed- Automobiles - Trucks - Buses

Start Time	US 41 Southbound				RIVERVIEW DR Westbound				US 41 Northbound				INDUSTRIAL ACCESS RD Eastbound				Int. Total
	Left	Thru	Right	U-Turns	Left	Thru	Right	U-Turns	Left	Thru	Right	U-Turns	Left	Thru	Right	U-Turns	
07:00 AM	3	97	5	0	30	4	15	0	14	423	46	0	1	6	5	0	649
07:15 AM	0	99	2	0	37	3	16	0	13	415	37	0	0	1	3	0	626
07:30 AM	2	115	2	0	28	2	33	0	17	416	43	0	1	2	4	0	665
07:45 AM	3	98	5	0	31	5	22	0	15	385	50	0	4	0	1	0	619
<b>Total</b>	<b>8</b>	<b>409</b>	<b>14</b>	<b>0</b>	<b>126</b>	<b>14</b>	<b>86</b>	<b>0</b>	<b>59</b>	<b>1639</b>	<b>176</b>	<b>0</b>	<b>6</b>	<b>9</b>	<b>13</b>	<b>0</b>	<b>2559</b>
08:00 AM	3	103	5	0	28	3	15	0	15	291	26	0	3	3	2	0	497
08:15 AM	4	100	10	0	20	7	11	0	6	294	34	1	4	0	1	0	492
08:30 AM	6	90	11	0	33	9	14	0	6	206	30	0	2	0	0	0	407
08:45 AM	4	38	3	0	26	8	7	0	11	174	25	0	1	5	3	0	305
<b>Total</b>	<b>17</b>	<b>331</b>	<b>29</b>	<b>0</b>	<b>107</b>	<b>27</b>	<b>47</b>	<b>0</b>	<b>38</b>	<b>965</b>	<b>115</b>	<b>1</b>	<b>10</b>	<b>8</b>	<b>6</b>	<b>0</b>	<b>1701</b>
<b>**BREAK**</b>																	
04:00 PM	32	316	3	0	46	0	4	0	3	131	36	0	7	7	14	0	599
04:15 PM	20	312	2	0	43	2	6	0	5	116	44	0	7	9	12	0	578
04:30 PM	30	339	2	0	47	0	4	0	3	115	22	0	7	4	5	0	578
04:45 PM	31	363	3	0	38	1	7	0	2	130	49	0	2	9	8	0	643
<b>Total</b>	<b>113</b>	<b>1330</b>	<b>10</b>	<b>0</b>	<b>174</b>	<b>3</b>	<b>21</b>	<b>0</b>	<b>13</b>	<b>492</b>	<b>151</b>	<b>0</b>	<b>23</b>	<b>29</b>	<b>39</b>	<b>0</b>	<b>2398</b>
05:00 PM	23	427	3	0	54	1	2	0	2	117	56	1	7	16	9	0	718
05:15 PM	23	424	3	0	55	0	7	0	1	123	47	1	4	2	8	0	698
05:30 PM	27	406	2	0	49	2	3	0	3	120	45	0	3	0	8	0	668
05:45 PM	25	362	7	0	50	2	0	0	5	109	57	0	2	3	5	0	627
<b>Total</b>	<b>98</b>	<b>1619</b>	<b>15</b>	<b>0</b>	<b>208</b>	<b>5</b>	<b>12</b>	<b>0</b>	<b>11</b>	<b>469</b>	<b>205</b>	<b>2</b>	<b>16</b>	<b>21</b>	<b>30</b>	<b>0</b>	<b>2711</b>
<b>Grand Total</b>	<b>236</b>	<b>3689</b>	<b>68</b>	<b>0</b>	<b>615</b>	<b>49</b>	<b>166</b>	<b>0</b>	<b>121</b>	<b>3565</b>	<b>647</b>	<b>3</b>	<b>55</b>	<b>67</b>	<b>88</b>	<b>0</b>	<b>9369</b>
Apprch %	5.9	92.4	1.7	0	74.1	5.9	20	0	2.8	82.2	14.9	0.1	26.2	31.9	41.9	0	
Total %	2.5	39.4	0.7	0	6.6	0.5	1.8	0	1.3	38.1	6.9	0	0.6	0.7	0.9	0	
Automobiles	233	3520	66	0	584	48	161	0	108	3403	614	3	54	67	81	0	8942
% Automobiles	98.7	95.4	97.1	0	95	98	97	0	89.3	95.5	94.9	100	98.2	100	92	0	95.4
Trucks	3	164	2	0	18	1	3	0	13	161	17	0	1	0	7	0	390
% Trucks	1.3	4.4	2.9	0	2.9	2	1.8	0	10.7	4.5	2.6	0	1.8	0	8	0	4.2
Buses	0	5	0	0	13	0	2	0	0	1	16	0	0	0	0	0	37
% Buses	0	0.1	0	0	2.1	0	1.2	0	0	0	2.5	0	0	0	0	0	0.4



# Southern Traffic Services, Inc.

2911 Westfield Rd  
 Gulf Breeze, FL 32563  
 1-800-786-3374

*Traffic is our only business!*

US 41 @ Riverview Dr  
 Tampa, FL

File Name : 13015-8 US 41 @ RIVERVIEW DR  
 Site Code : 13015-8  
 Start Date : 1/10/2013  
 Page No : 2

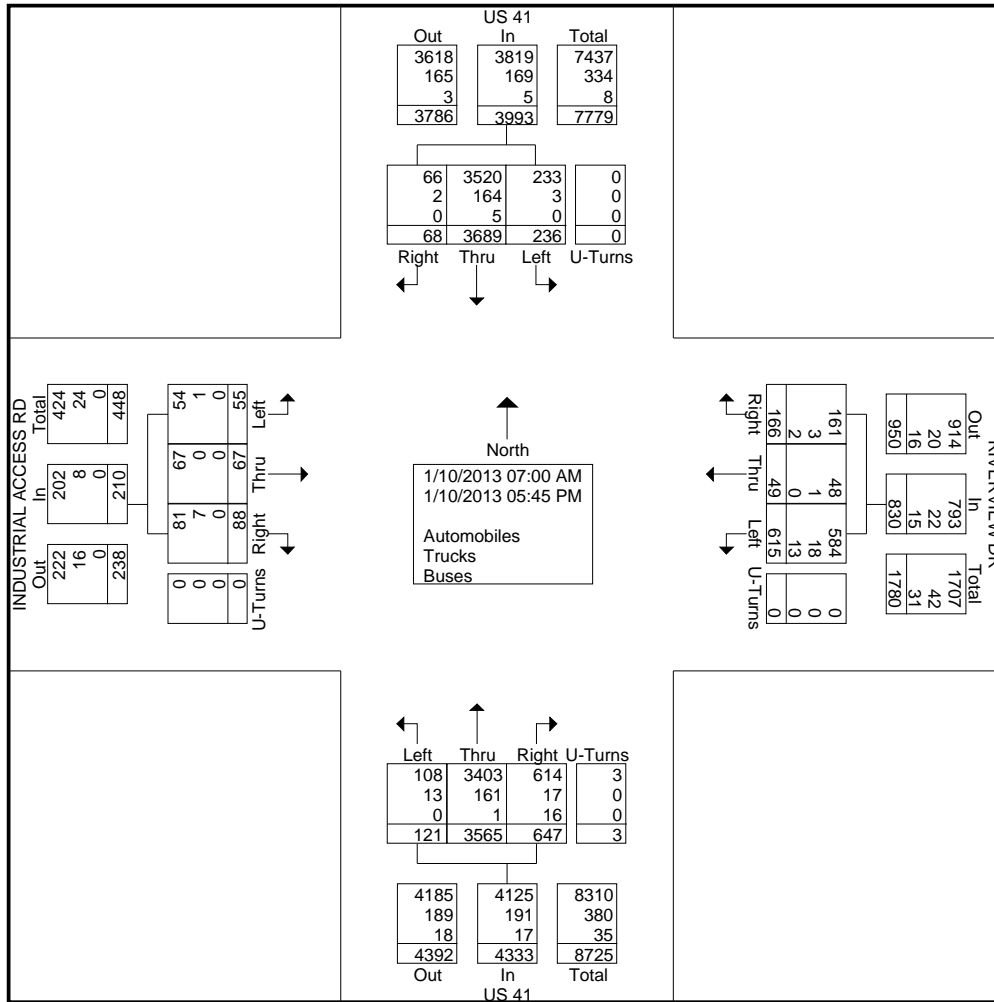



# Southern Traffic Services, Inc.

2911 Westfield Rd  
Gulf Breeze, FL 32563  
1-800-786-3374

*Traffic is our only business!*

US 41 @ Riverview Dr  
Tampa, FL

File Name : 13015-8 US 41 @ RIVERVIEW DR  
Site Code : 13015-8  
Start Date : 1/10/2013  
Page No : 3

Start Time	US 41 Southbound				RIVERVIEW DR Westbound				US 41 Northbound				INDUSTRIAL ACCESS RD Eastbound				Int. Total				
	Thru	Right	U-Turns	App. Total	Left	Thru	Right	U-Turns	App. Total	Left	Thru	Right	U-Turns	App. Total	Left	Thru		Right	U-Turns	App. Total	
Peak Hour Analysis From 07:00 AM to 11:45 AM - Peak 1 of 1																					
Peak Hour for Entire Intersection Begins at 07:00 AM																					
07:00 AM	3	97	5	0	105	30	4	15	0	49	14	423	46	0	483	1	6	5	0	12	649
07:15 AM	0	99	2	0	101	37	3	16	0	56	13	415	37	0	465	0	1	3	0	4	626
07:30 AM	2	115	2	0	119	28	2	33	0	63	17	416	43	0	476	1	2	4	0	7	665
07:45 AM	3	98	5	0	106	31	5	22	0	58	15	385	50	0	450	4	0	1	0	5	619
Total Volume	8	409	14	0	431	126	14	86	0	226	59	1639	176	0	1874	6	9	13	0	28	2559
% App. Total	1.9	94.9	3.2	0		55.8	6.2	38.1	0		3.1	87.5	9.4	0		21.4	32.1	46.4	0		
PHF	.667	.889	.700	.000	.905	.851	.700	.652	.000	.897	.868	.969	.880	.000	.970	.375	.375	.650	.000	.583	.962
Automobiles	8	337	12	0	357	117	14	82	0	213	47	1607	169	0	1823	5	9	10	0	24	2417
% Automobiles	100	82.4	85.7	0	82.8	92.9	100	95.3	0	94.2	79.7	98.0	96.0	0	97.3	83.3	100	76.9	0	85.7	94.5
Trucks	0	70	2	0	72	2	0	3	0	5	12	32	2	0	46	1	0	3	0	4	127
% Trucks	0	17.1	14.3	0	16.7	1.6	0	3.5	0	2.2	20.3	2.0	1.1	0	2.5	16.7	0	23.1	0	14.3	5.0
Buses	0	2	0	0	2	7	0	1	0	8	0	0	5	0	5	0	0	0	0	0	15
% Buses	0	0.5	0	0	0.5	5.6	0	1.2	0	3.5	0	0	2.8	0	0.3	0	0	0	0	0	0.6

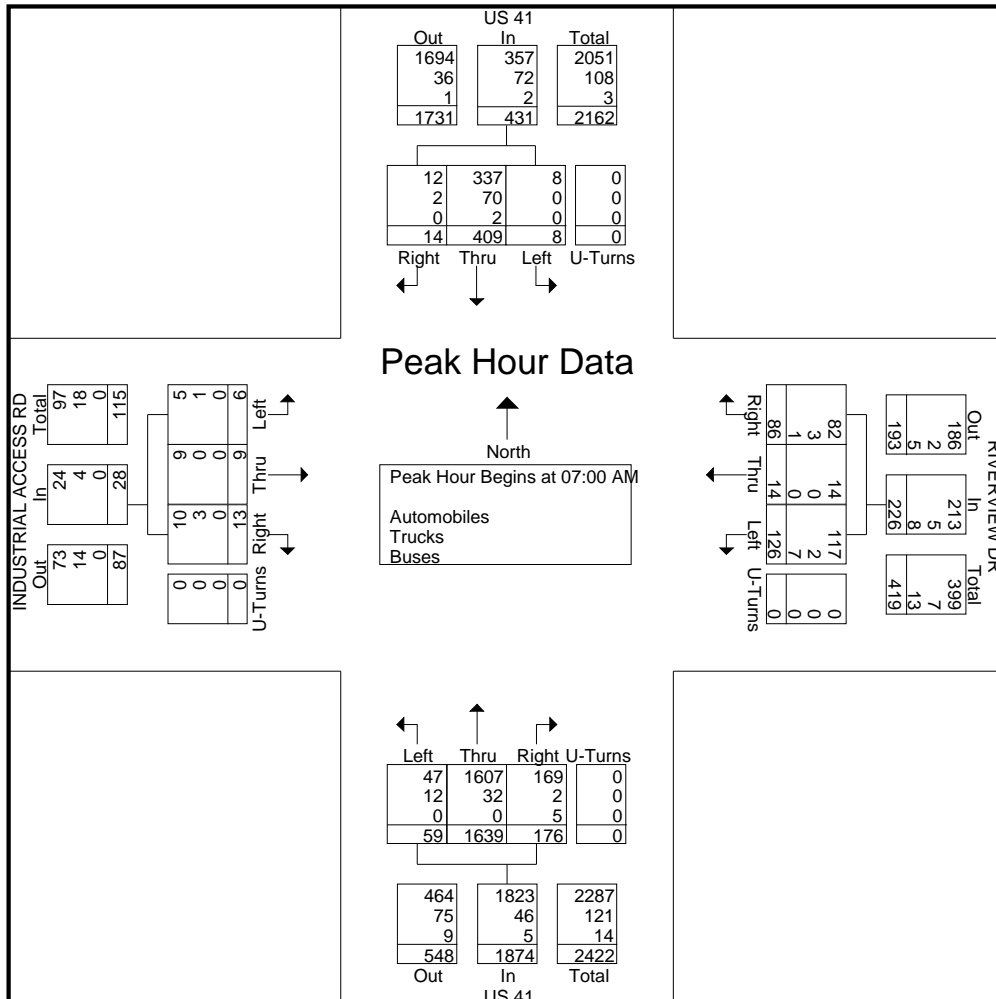



# Southern Traffic Services, Inc.

2911 Westfield Rd  
Gulf Breeze, FL 32563  
1-800-786-3374

*Traffic is our only business!*

US 41 @ Riverview Dr  
Tampa, FL

File Name : 13015-8 US 41 @ RIVERVIEW DR  
Site Code : 13015-8  
Start Date : 1/10/2013  
Page No : 4

Start Time	US 41 Southbound					RIVERVIEW DR Westbound					US 41 Northbound					INDUSTRIAL ACCESS RD Eastbound					Int. Total
	Left	Thru	Right	U-Turns	App. Total	Left	Thru	Right	U-Turns	App. Total	Left	Thru	Right	U-Turns	App. Total	Left	Thru	Right	U-Turns	App. Total	

Peak Hour Analysis From 12:00 PM to 05:45 PM - Peak 1 of 1

Peak Hour for Entire Intersection Begins at 04:45 PM

04:45 PM	31	363	3	0	397	38	1	7	0	46	2	130	49	0	181	2	9	8	0	19	643
05:00 PM	23	427	3	0	453	54	1	2	0	57	2	117	56	1	176	7	16	9	0	32	718
05:15 PM	23	424	3	0	450	55	0	7	0	62	1	123	47	1	172	4	2	8	0	14	698
05:30 PM	27	406	2	0	435	49	2	3	0	54	3	120	45	0	168	3	0	8	0	11	668
Total Volume	104	1620	11	0	1735	196	4	19	0	219	8	490	197	2	697	16	27	33	0	76	2727
% App. Total	6	93.4	0.6	0		89.5	1.8	8.7	0		1.1	70.3	28.3	0.3		21.1	35.5	43.4	0		
PHF	.839	.948	.917	.000	.958	.891	.500	.679	.000	.883	.667	.942	.879	.500	.963	.571	.422	.917	.000	.594	.950
Automobiles	102	1607	11	0	1720	191	4	19	0	214	8	453	191	2	654	16	27	32	0	75	2663
% Automobiles	98.1	99.2	100	0	99.1	97.4	100	100	0	97.7	100	92.4	97.0	100	93.8	100	100	97.0	0	98.7	97.7
Trucks	2	11	0	0	13	5	0	0	0	5	0	37	3	0	40	0	0	1	0	1	59
% Trucks	1.9	0.7	0	0	0.7	2.6	0	0	0	2.3	0	7.6	1.5	0	5.7	0	0	3.0	0	1.3	2.2
Buses	0	2	0	0	2	0	0	0	0	0	0	0	3	0	3	0	0	0	0	0	5
% Buses	0	0.1	0	0	0.1	0	0	0	0	0	0	0	1.5	0	0.4	0	0	0	0	0	0.2

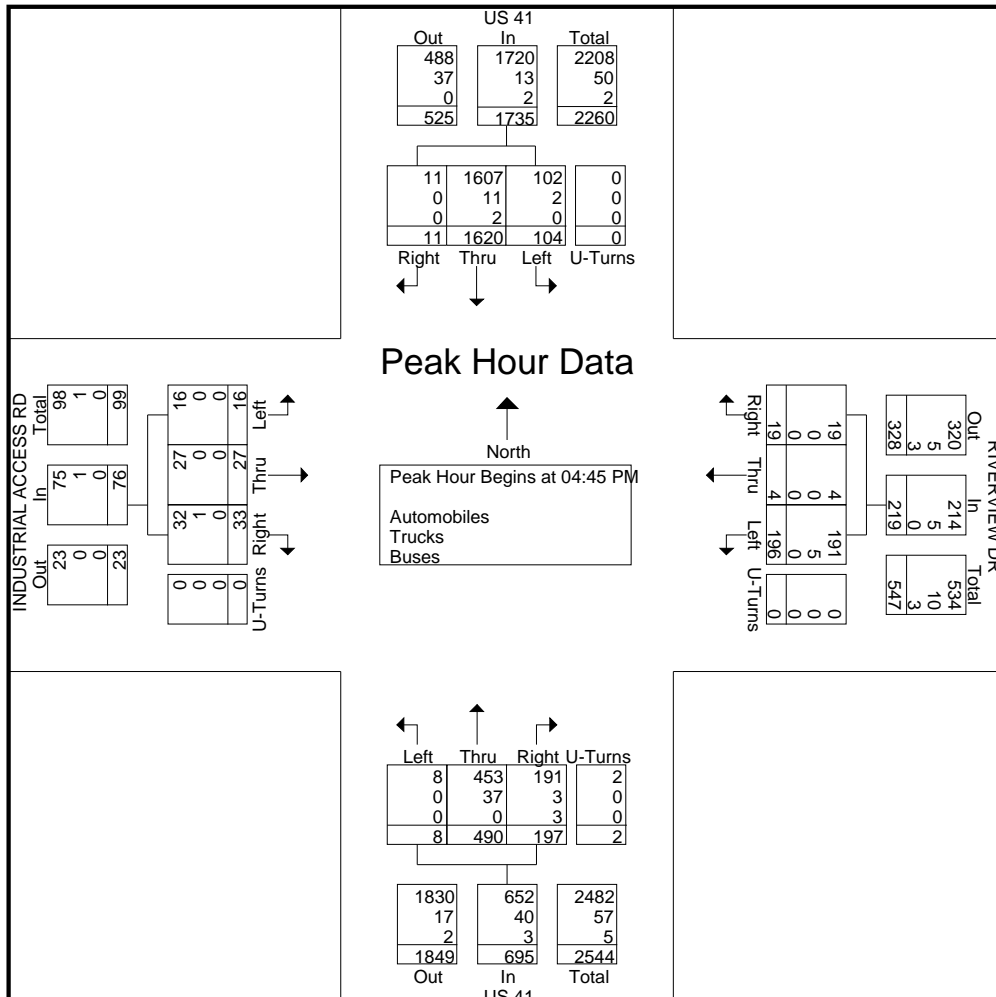



# Southern Traffic Services, Inc.

2911 Westfield Rd  
Gulf Breeze, FL 32563  
1-800-786-3374

*Traffic is our only business!*

US 41 @ Riverview Dr  
Tampa, FL

File Name : 13015-8 US 41 @ RIVERVIEW DR  
Site Code : 13015-8  
Start Date : 1/10/2013  
Page No : 1

Groups Printed- Automobiles

Start Time	US 41 Southbound				RIVERVIEW DR Westbound				US 41 Northbound				INDUSTRIAL ACCESS RD Eastbound				Int. Total
	Left	Thru	Right	U-Turns	Left	Thru	Right	U-Turns	Left	Thru	Right	U-Turns	Left	Thru	Right	U-Turns	
07:00 AM	3	76	5	0	28	4	15	0	10	418	45	0	1	6	5	0	616
07:15 AM	0	82	2	0	34	3	13	0	12	404	36	0	0	1	2	0	589
07:30 AM	2	96	1	0	25	2	32	0	11	405	41	0	0	2	3	0	620
07:45 AM	3	83	4	0	30	5	22	0	14	380	47	0	4	0	0	0	592
<b>Total</b>	<b>8</b>	<b>337</b>	<b>12</b>	<b>0</b>	<b>117</b>	<b>14</b>	<b>82</b>	<b>0</b>	<b>47</b>	<b>1607</b>	<b>169</b>	<b>0</b>	<b>5</b>	<b>9</b>	<b>10</b>	<b>0</b>	<b>2417</b>
08:00 AM	3	88	5	0	26	3	15	0	14	277	24	0	3	3	1	0	462
08:15 AM	4	82	10	0	19	7	11	0	6	281	31	1	4	0	0	0	456
08:30 AM	6	74	11	0	31	9	14	0	6	193	29	0	2	0	0	0	375
08:45 AM	4	28	3	0	23	7	7	0	11	163	22	0	1	5	3	0	277
<b>Total</b>	<b>17</b>	<b>272</b>	<b>29</b>	<b>0</b>	<b>99</b>	<b>26</b>	<b>47</b>	<b>0</b>	<b>37</b>	<b>914</b>	<b>106</b>	<b>1</b>	<b>10</b>	<b>8</b>	<b>4</b>	<b>0</b>	<b>1570</b>
<b>**BREAK**</b>																	
04:00 PM	31	308	3	0	43	0	3	0	3	123	33	0	7	7	14	0	575
04:15 PM	20	301	2	0	40	2	6	0	5	98	41	0	7	9	11	0	542
04:30 PM	30	335	2	0	45	0	4	0	3	101	21	0	7	4	5	0	557
04:45 PM	31	355	3	0	38	1	7	0	2	115	47	0	2	9	8	0	618
<b>Total</b>	<b>112</b>	<b>1299</b>	<b>10</b>	<b>0</b>	<b>166</b>	<b>3</b>	<b>20</b>	<b>0</b>	<b>13</b>	<b>437</b>	<b>142</b>	<b>0</b>	<b>23</b>	<b>29</b>	<b>38</b>	<b>0</b>	<b>2292</b>
05:00 PM	22	425	3	0	50	1	2	0	2	107	54	1	7	16	8	0	698
05:15 PM	23	424	3	0	54	0	7	0	1	116	47	1	4	2	8	0	690
05:30 PM	26	403	2	0	49	2	3	0	3	115	43	0	3	0	8	0	657
05:45 PM	25	360	7	0	49	2	0	0	5	107	53	0	2	3	5	0	618
<b>Total</b>	<b>96</b>	<b>1612</b>	<b>15</b>	<b>0</b>	<b>202</b>	<b>5</b>	<b>12</b>	<b>0</b>	<b>11</b>	<b>445</b>	<b>197</b>	<b>2</b>	<b>16</b>	<b>21</b>	<b>29</b>	<b>0</b>	<b>2663</b>
<b>Grand Total</b>	<b>233</b>	<b>3520</b>	<b>66</b>	<b>0</b>	<b>584</b>	<b>48</b>	<b>161</b>	<b>0</b>	<b>108</b>	<b>3403</b>	<b>614</b>	<b>3</b>	<b>54</b>	<b>67</b>	<b>81</b>	<b>0</b>	<b>8942</b>
Apprch %	6.1	92.2	1.7	0	73.6	6.1	20.3	0	2.6	82.4	14.9	0.1	26.7	33.2	40.1	0	
Total %	2.6	39.4	0.7	0	6.5	0.5	1.8	0	1.2	38.1	6.9	0	0.6	0.7	0.9	0	



# Southern Traffic Services, Inc.

2911 Westfield Rd  
Gulf Breeze, FL 32563  
1-800-786-3374

*Traffic is our only business!*

US 41 @ Riverview Dr  
Tampa, FL

File Name : 13015-8 US 41 @ RIVERVIEW DR  
Site Code : 13015-8  
Start Date : 1/10/2013  
Page No : 2

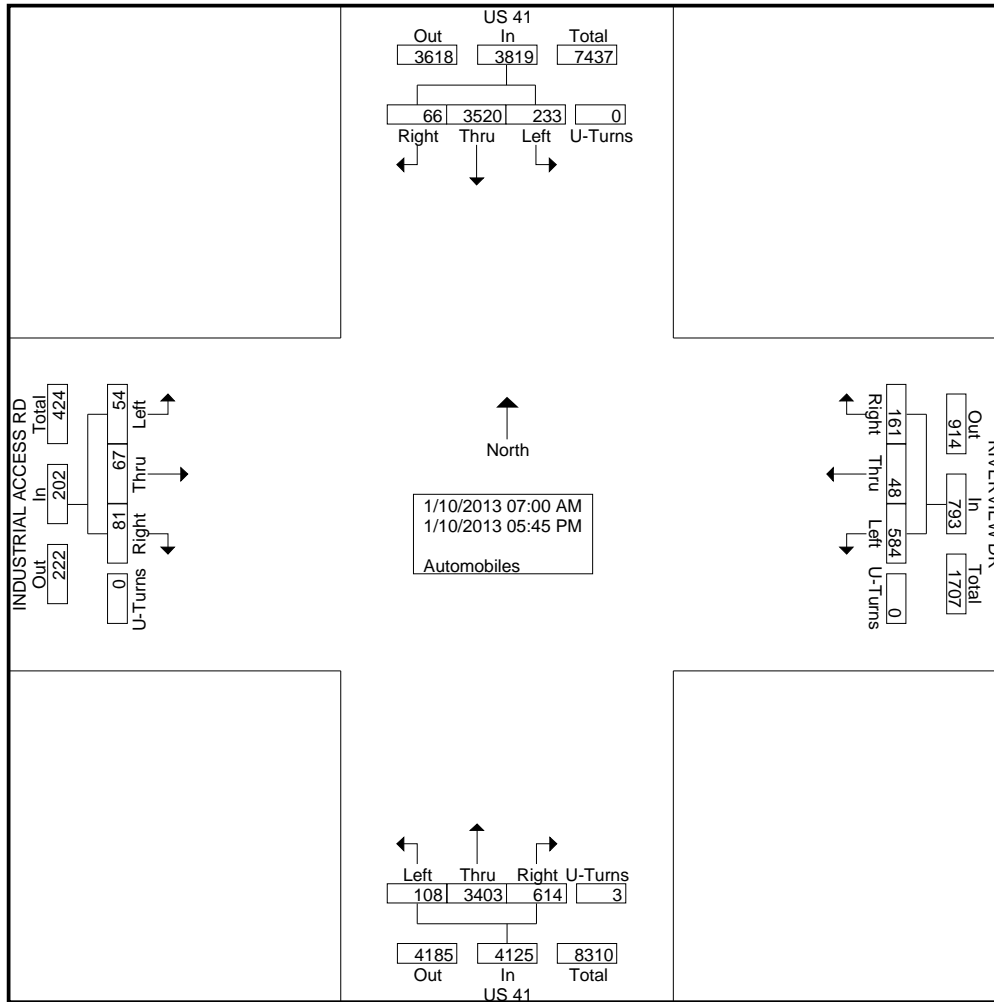



# Southern Traffic Services, Inc.

2911 Westfield Rd  
Gulf Breeze, FL 32563  
1-800-786-3374

*Traffic is our only business!*

US 41 @ Riverview Dr  
Tampa, FL

File Name : 13015-8 US 41 @ RIVERVIEW DR  
Site Code : 13015-8  
Start Date : 1/10/2013  
Page No : 3

Start Time	US 41 Southbound				RIVERVIEW DR Westbound				US 41 Northbound				INDUSTRIAL ACCESS RD Eastbound				Int. Total				
	Thru	Right	U-Turns	App. Total	Left	Thru	Right	U-Turns	App. Total	Left	Thru	Right	U-Turns	App. Total	Left	Thru		Right	U-Turns	App. Total	
Peak Hour Analysis From 07:00 AM to 11:45 AM - Peak 1 of 1																					
Peak Hour for Entire Intersection Begins at 07:00 AM																					
07:00 AM	3	76	5	0	84	28	4	15	0	47	10	418	45	0	473	1	6	5	0	12	616
07:15 AM	0	82	2	0	84	34	3	13	0	50	12	404	36	0	452	0	1	2	0	3	589
07:30 AM	2	96	1	0	99	25	2	32	0	59	11	405	41	0	457	0	2	3	0	5	620
07:45 AM	3	83	4	0	90	30	5	22	0	57	14	380	47	0	441	4	0	0	0	4	592
Total Volume	8	337	12	0	357	117	14	82	0	213	47	1607	169	0	1823	5	9	10	0	24	2417
% App. Total	2.2	94.4	3.4	0		54.9	6.6	38.5	0		2.6	88.2	9.3	0		20.8	37.5	41.7	0		
PHF	.667	.878	.600	.000	.902	.860	.700	.641	.000	.903	.839	.961	.899	.000	.964	.313	.375	.500	.000	.500	.975

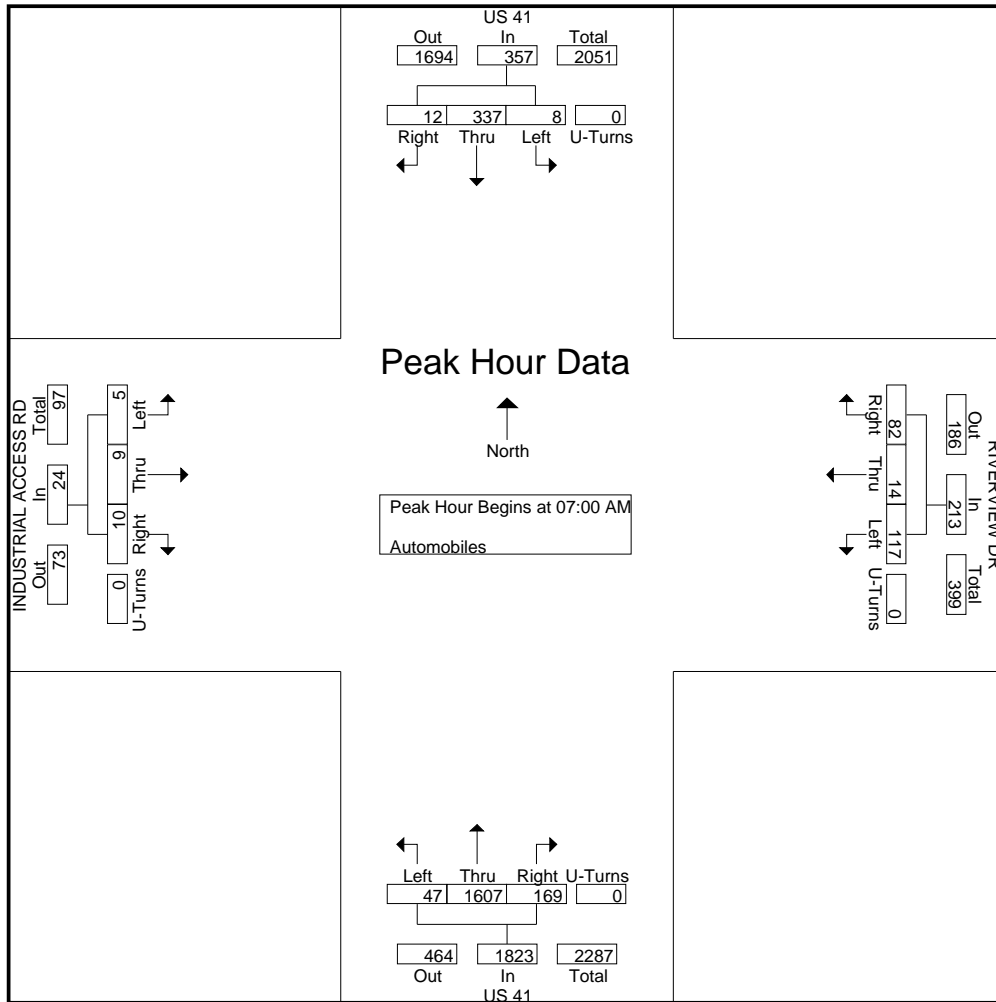





# Southern Traffic Services, Inc.

2911 Westfield Rd  
Gulf Breeze, FL 32563  
1-800-786-3374

*Traffic is our only business!*

US 41 @ Riverview Dr  
Tampa, FL

File Name : 13015-8 US 41 @ RIVERVIEW DR  
Site Code : 13015-8  
Start Date : 1/10/2013  
Page No : 4

Start Time	US 41 Southbound					RIVERVIEW DR Westbound					US 41 Northbound					INDUSTRIAL ACCESS RD Eastbound					Int. Total
	Left	Thru	Right	U-Turns	App. Total	Left	Thru	Right	U-Turns	App. Total	Left	Thru	Right	U-Turns	App. Total	Left	Thru	Right	U-Turns	App. Total	
Peak Hour Analysis From 12:00 PM to 05:45 PM - Peak 1 of 1																					
Peak Hour for Entire Intersection Begins at 04:45 PM																					
04:45 PM	31	355	3	0	389	38	1	7	0	46	2	115	47	0	164	2	9	8	0	19	618
05:00 PM	22	425	3	0	450	50	1	2	0	53	2	107	54	1	164	7	16	8	0	31	698
05:15 PM	23	424	3	0	450	54	0	7	0	61	1	116	47	1	165	4	2	8	0	14	690
05:30 PM	26	403	2	0	431	49	2	3	0	54	3	115	43	0	161	3	0	8	0	11	657
Total Volume	102	1607	11	0	1720	191	4	19	0	214	8	453	191	2	654	16	27	32	0	75	2663
% App. Total	5.9	93.4	0.6	0		89.3	1.9	8.9	0		1.2	69.3	29.2	0.3		21.3	36	42.7	0		
PHF	.823	.945	.917	.000	.956	.884	.500	.679	.000	.877	.667	.976	.884	.500	.991	.571	.422	1.00	.000	.605	.954

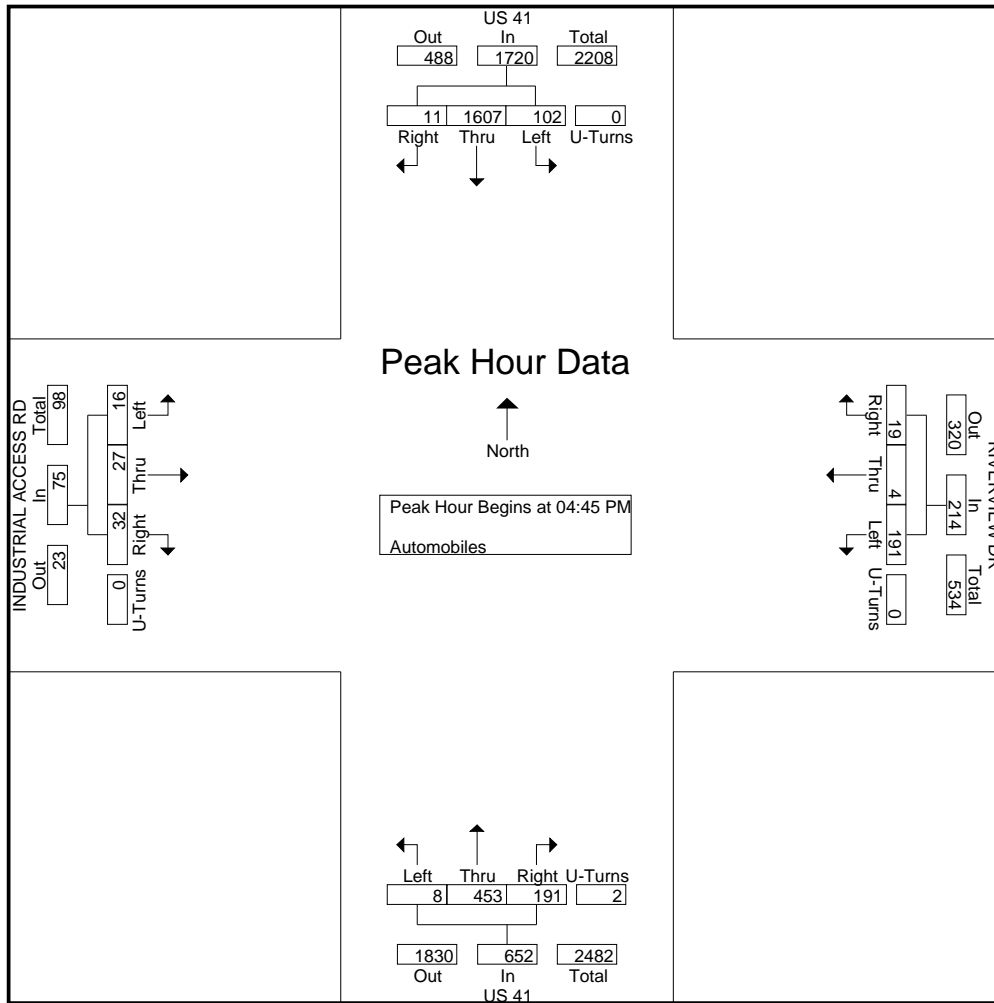



# Southern Traffic Services, Inc.

2911 Westfield Rd  
Gulf Breeze, FL 32563  
1-800-786-3374

*Traffic is our only business!*

US 41 @ Riverview Dr  
Tampa, FL

File Name : 13015-8 US 41 @ RIVERVIEW DR  
Site Code : 13015-8  
Start Date : 1/10/2013  
Page No : 1

Groups Printed- Trucks - Buses

Start Time	US 41 Southbound				RIVERVIEW DR Westbound				US 41 Northbound				INDUSTRIAL ACCESS RD Eastbound				Int. Total	
	Left	Thru	Right	U-Turns	Left	Thru	Right	U-Turns	Left	Thru	Right	U-Turns	Left	Thru	Right	U-Turns		
07:00 AM	0	21	0	0	2	0	0	0	4	5	1	0	0	0	0	0	0	33
07:15 AM	0	17	0	0	3	0	3	0	1	11	1	0	0	0	1	0	0	37
07:30 AM	0	19	1	0	3	0	1	0	6	11	2	0	1	0	1	0	0	45
07:45 AM	0	15	1	0	1	0	0	0	1	5	3	0	0	0	1	0	0	27
Total	0	72	2	0	9	0	4	0	12	32	7	0	1	0	3	0	0	142
08:00 AM	0	15	0	0	2	0	0	0	1	14	2	0	0	0	1	0	0	35
08:15 AM	0	18	0	0	1	0	0	0	0	13	3	0	0	0	1	0	0	36
08:30 AM	0	16	0	0	2	0	0	0	0	13	1	0	0	0	0	0	0	32
08:45 AM	0	10	0	0	3	1	0	0	0	11	3	0	0	0	0	0	0	28
Total	0	59	0	0	8	1	0	0	1	51	9	0	0	0	2	0	0	131
<b>**BREAK**</b>																		
04:00 PM	1	8	0	0	3	0	1	0	0	8	3	0	0	0	0	0	0	24
04:15 PM	0	11	0	0	3	0	0	0	0	18	3	0	0	0	1	0	0	36
04:30 PM	0	4	0	0	2	0	0	0	0	14	1	0	0	0	0	0	0	21
04:45 PM	0	8	0	0	0	0	0	0	0	15	2	0	0	0	0	0	0	25
Total	1	31	0	0	8	0	1	0	0	55	9	0	0	0	1	0	0	106
05:00 PM	1	2	0	0	4	0	0	0	0	10	2	0	0	0	1	0	0	20
05:15 PM	0	0	0	0	1	0	0	0	0	7	0	0	0	0	0	0	0	8
05:30 PM	1	3	0	0	0	0	0	0	0	5	2	0	0	0	0	0	0	11
05:45 PM	0	2	0	0	1	0	0	0	0	2	4	0	0	0	0	0	0	9
Total	2	7	0	0	6	0	0	0	0	24	8	0	0	0	1	0	0	48
Grand Total	3	169	2	0	31	1	5	0	13	162	33	0	1	0	7	0	0	427
Apprch %	1.7	97.1	1.1	0	83.8	2.7	13.5	0	6.2	77.9	15.9	0	12.5	0	87.5	0	0	
Total %	0.7	39.6	0.5	0	7.3	0.2	1.2	0	3	37.9	7.7	0	0.2	0	1.6	0	0	
Trucks	3	164	2	0	18	1	3	0	13	161	17	0	1	0	7	0	0	390
% Trucks	100	97	100	0	58.1	100	60	0	100	99.4	51.5	0	100	0	100	0	0	91.3
Buses	0	5	0	0	13	0	2	0	0	1	16	0	0	0	0	0	0	37
% Buses	0	3	0	0	41.9	0	40	0	0	0.6	48.5	0	0	0	0	0	0	8.7



# Southern Traffic Services, Inc.

2911 Westfield Rd  
 Gulf Breeze, FL 32563  
 1-800-786-3374

*Traffic is our only business!*

US 41 @ Riverview Dr  
 Tampa, FL

File Name : 13015-8 US 41 @ RIVERVIEW DR  
 Site Code : 13015-8  
 Start Date : 1/10/2013  
 Page No : 2

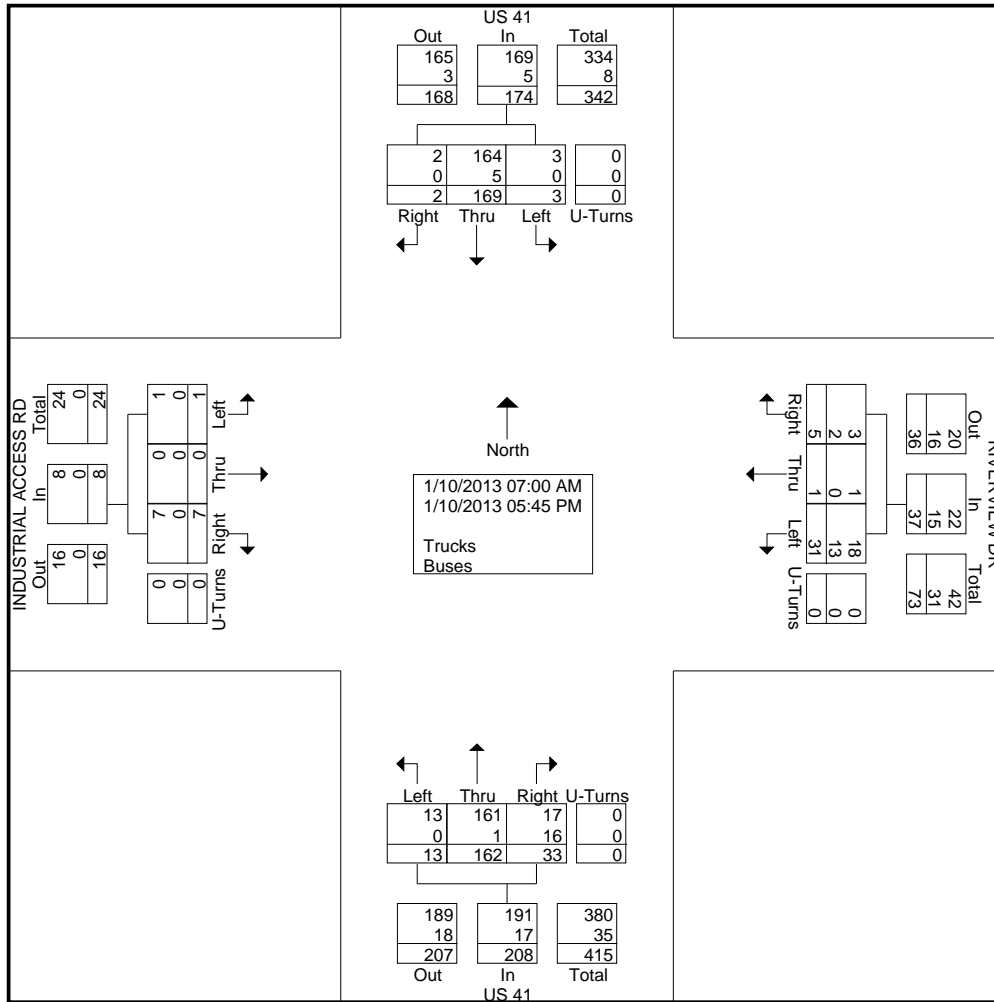



# Southern Traffic Services, Inc.

2911 Westfield Rd  
 Gulf Breeze, FL 32563  
 1-800-786-3374

*Traffic is our only business!*

US 41 @ Riverview Dr  
 Tampa, FL

File Name : 13015-8 US 41 @ RIVERVIEW DR  
 Site Code : 13015-8  
 Start Date : 1/10/2013  
 Page No : 3

Start Time	US 41 Southbound				RIVERVIEW DR Westbound				US 41 Northbound				INDUSTRIAL ACCESS RD Eastbound				Int. Total				
	Thru	Right	U-Turns	App. Total	Left	Thru	Right	U-Turns	App. Total	Left	Thru	Right	U-Turns	App. Total	Left	Thru		Right	U-Turns	App. Total	
Peak Hour Analysis From 07:00 AM to 11:45 AM - Peak 1 of 1																					
Peak Hour for Entire Intersection Begins at 07:15 AM																					
07:15 AM	0	17	0	0	17	3	0	3	0	6	1	11	1	0	13	0	0	1	0	1	37
07:30 AM	0	19	1	0	20	3	0	1	0	4	6	11	2	0	19	1	0	1	0	2	45
07:45 AM	0	15	1	0	16	1	0	0	0	1	1	5	3	0	9	0	0	1	0	1	27
08:00 AM	0	15	0	0	15	2	0	0	0	2	1	14	2	0	17	0	0	1	0	1	35
Total Volume	0	66	2	0	68	9	0	4	0	13	9	41	8	0	58	1	0	4	0	5	144
% App. Total	0	97.1	2.9	0		69.2	0	30.8	0		15.5	70.7	13.8	0		20	0	80	0		
PHF	.000	.868	.500	.000	.850	.750	.000	.333	.000	.542	.375	.732	.667	.000	.763	.250	.000	1.00	.000	.625	.800

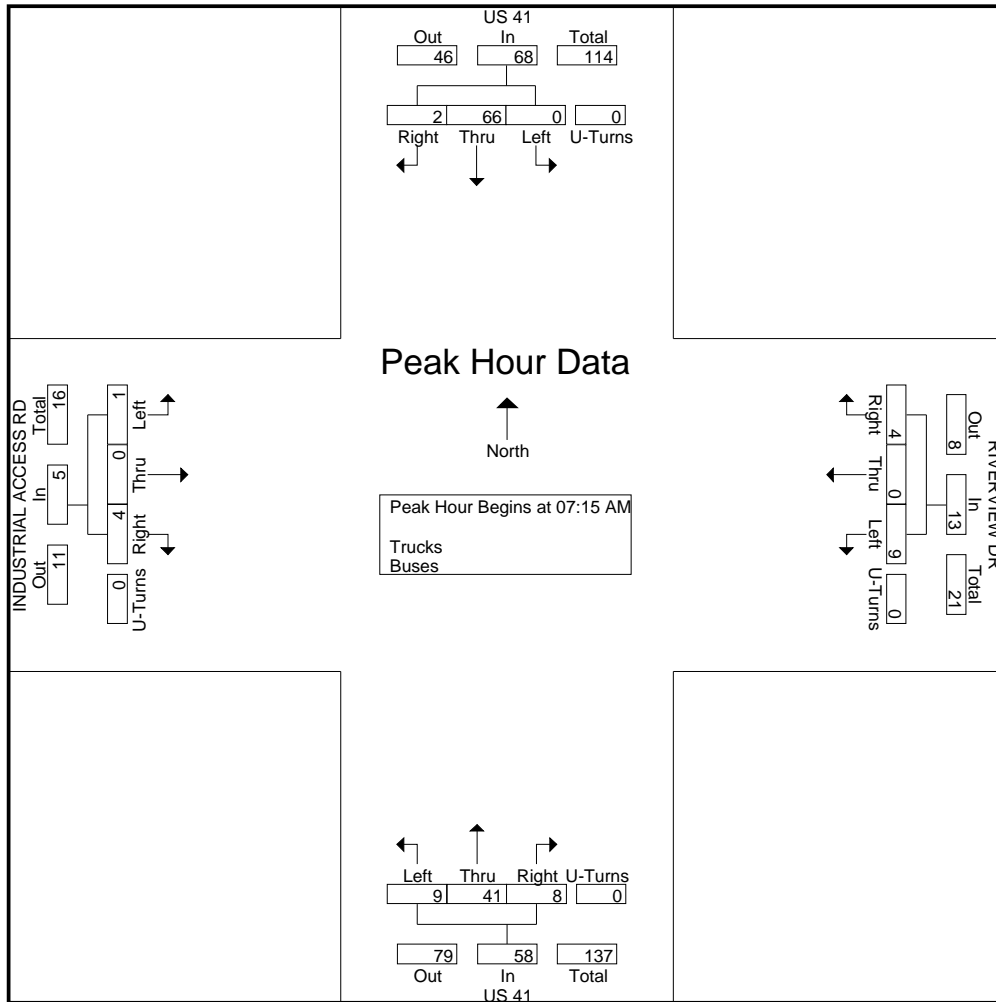



# Southern Traffic Services, Inc.

2911 Westfield Rd  
Gulf Breeze, FL 32563  
1-800-786-3374

*Traffic is our only business!*

US 41 @ Riverview Dr  
Tampa, FL

File Name : 13015-8 US 41 @ RIVERVIEW DR  
Site Code : 13015-8  
Start Date : 1/10/2013  
Page No : 4

Start Time	US 41 Southbound					RIVERVIEW DR Westbound					US 41 Northbound					INDUSTRIAL ACCESS RD Eastbound					Int. Total
	Left	Thru	Right	U-Turns	App. Total	Left	Thru	Right	U-Turns	App. Total	Left	Thru	Right	U-Turns	App. Total	Left	Thru	Right	U-Turns	App. Total	
Peak Hour Analysis From 12:00 PM to 05:45 PM - Peak 1 of 1																					
Peak Hour for Entire Intersection Begins at 04:00 PM																					
04:00 PM	1	8	0	0	9	3	0	1	0	4	0	8	3	0	11	0	0	0	0	0	24
04:15 PM	0	11	0	0	11	3	0	0	0	3	0	18	3	0	21	0	0	1	0	1	36
04:30 PM	0	4	0	0	4	2	0	0	0	2	0	14	1	0	15	0	0	0	0	0	21
04:45 PM	0	8	0	0	8	0	0	0	0	0	0	15	2	0	17	0	0	0	0	0	25
Total Volume	1	31	0	0	32	8	0	1	0	9	0	55	9	0	64	0	0	1	0	1	106
% App. Total	3.1	96.9	0	0		88.9	0	11.1	0		0	85.9	14.1	0		0	0	100	0		
PHF	.250	.705	.000	.000	.727	.667	.000	.250	.000	.563	.000	.764	.750	.000	.762	.000	.000	.250	.000	.250	.736

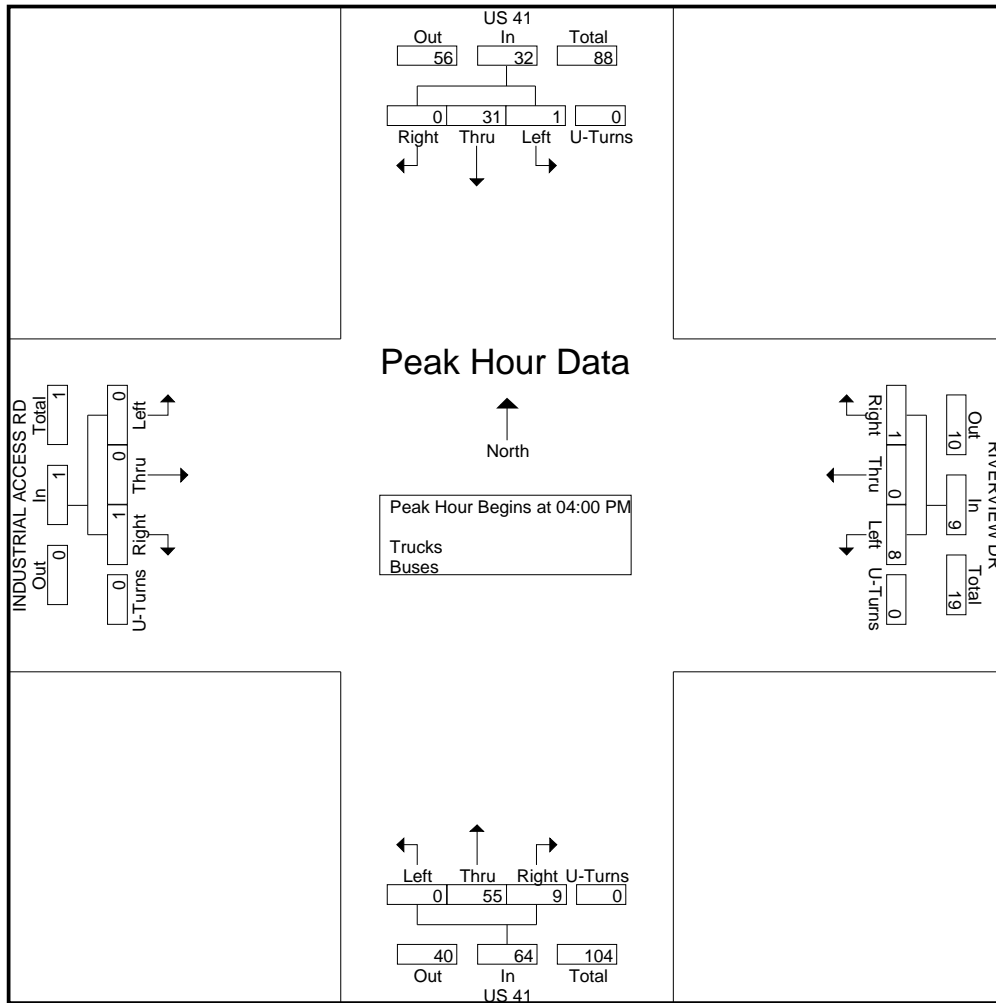



# Southern Traffic Services, Inc.

2911 Westfield Rd  
Gulf Breeze, FL 32563  
1-800-786-3374

*Traffic is our only business!*

US 41 @ Riverview Dr  
Tampa, FL

File Name : 13015-8 US 41 @ Riverview Dr Peds  
Site Code : 13015-8  
Start Date : 1/10/2013  
Page No : 1

### Groups Printed- Peds

	US 41 Southbound	RIVERVIEW DR Westbound	US 41 Northbound	INDUSTRIAL ACCESS RD Eastbound	Int. Total
Start Time	Peds	Peds	Peds	Peds	
07:00 AM	0	0	0	2	2
07:15 AM	0	0	0	0	0
07:30 AM	0	0	0	1	1
07:45 AM	0	0	0	1	1
Total	0	0	0	4	4
08:00 AM	0	0	0	0	0
08:15 AM	0	0	0	0	0
08:30 AM	0	0	0	0	0
08:45 AM	0	0	0	0	0
Total	0	0	0	0	0
09:00 AM	0	0	0	0	0
09:15 AM	0	0	0	0	0
09:30 AM	0	0	0	0	0
09:45 AM	0	0	0	0	0
Total	0	0	0	0	0
10:00 AM	0	0	0	0	0
10:15 AM	0	0	0	0	0
10:30 AM	0	0	0	0	0
10:45 AM	0	0	0	0	0
Total	0	0	0	0	0
11:00 AM	0	0	0	0	0
11:15 AM	0	0	0	0	0
11:30 AM	0	0	0	0	0
11:45 AM	0	0	0	0	0
Total	0	0	0	0	0
12:00 PM	0	0	0	0	0
12:15 PM	0	0	0	0	0
12:30 PM	0	0	0	0	0
12:45 PM	0	0	0	0	0
Total	0	0	0	0	0
01:00 PM	0	0	0	0	0
01:15 PM	0	0	0	0	0
01:30 PM	0	0	0	0	0
01:45 PM	0	0	0	0	0
Total	0	0	0	0	0
02:00 PM	0	0	0	0	0
02:15 PM	0	0	0	0	0
02:30 PM	0	0	0	0	0
02:45 PM	0	0	0	0	0
Total	0	0	0	0	0
03:00 PM	0	0	0	0	0
03:15 PM	0	0	0	0	0
03:30 PM	0	0	0	0	0
03:45 PM	0	0	0	0	0
Total	0	0	0	0	0



# Southern Traffic Services, Inc.

2911 Westfield Rd  
 Gulf Breeze, FL 32563  
 1-800-786-3374

*Traffic is our only business!*

US 41 @ Riverview Dr  
 Tampa, FL

File Name : 13015-8 US 41 @ Riverview Dr Peds  
 Site Code : 13015-8  
 Start Date : 1/10/2013  
 Page No : 2

Groups Printed- Peds

	US 41 Southbound	RIVERVIEW DR Westbound	US 41 Northbound	INDUSTRIAL ACCESS RD Eastbound	Int. Total
Start Time	Peds	Peds	Peds	Peds	
04:00 PM	0	0	0	0	0
04:15 PM	0	0	0	0	0
04:30 PM	0	0	0	0	0
04:45 PM	0	0	0	0	0
Total	0	0	0	0	0
05:00 PM	0	0	0	0	0
05:15 PM	0	0	0	0	0
05:30 PM	0	0	1	0	1
05:45 PM	0	0	0	0	0
Total	0	0	1	0	1
Grand Total	0	0	1	4	5
Apprch %	0	0	100	100	
Total %	0	0	20	80	

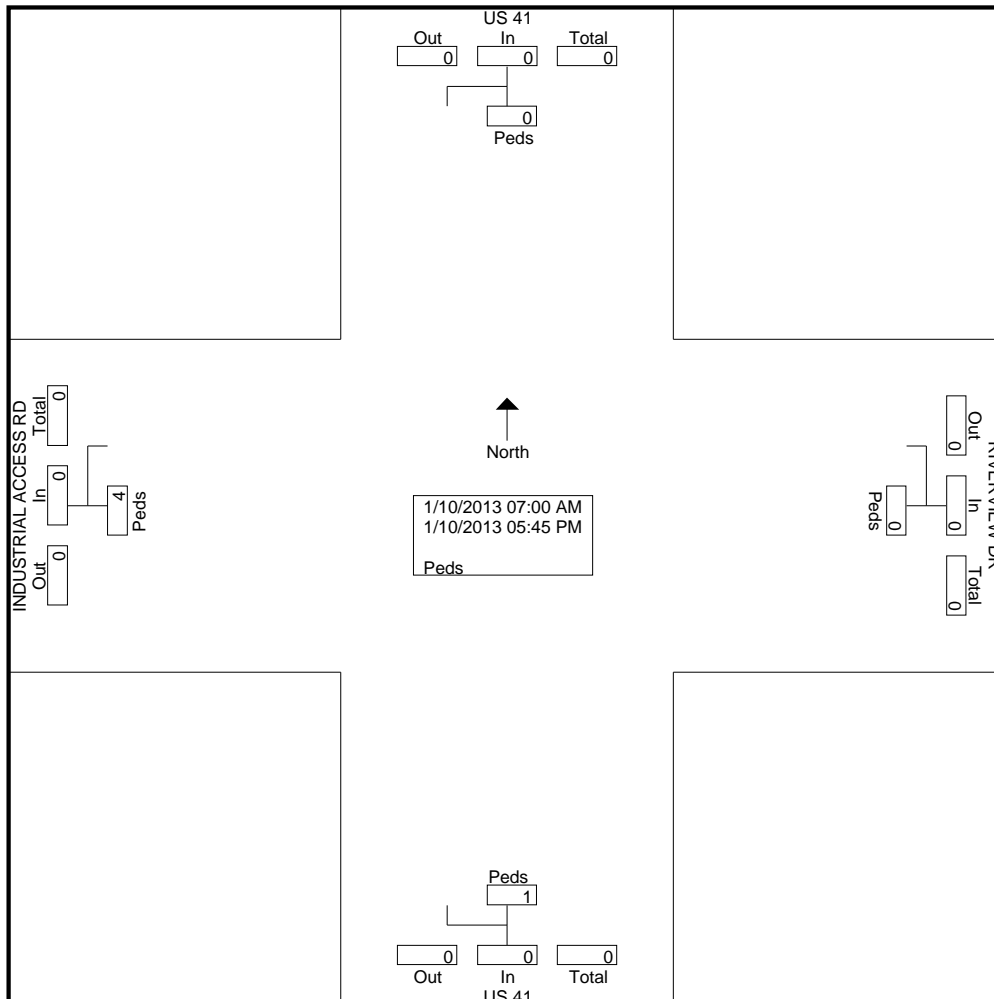

# Southern Traffic Services, Inc.

## Event Counts

**US 41 north of Riverview Drive**

**Northbound**

**Datasets:**

**Site:** [081] I6547  
**Input A:** 5 - South bound A>B, North bound B>A. - Excluded from totals. (0)  
**Input B:** 0 - Unused or unknown. - Added to totals. (1)  
**Survey Duration:** 17:26 Monday, January 14, 2013 => 14:45 Friday, January 18, 2013  
**File:** G:\DATA\2013\Private\13015\resets\UM081.eco (Plus)  
**Identifier:** T501XEYX MC56-L5 [MC55] (c)Microcom 19Oct04  
**Algorithm:** Event Count  
**Data type:** Axle sensors - Paired (Class, Speed, Count)

**Profile:**

**Filter time:** 0:00 Tuesday, January 15, 2013 => 0:00 Friday, January 18, 2013  
**Name:** Factory default profile  
**Scheme:** Count events divided by two.  
**Units:** Non metric (ft, mi, ft/s, mph, lb, ton)  
**In profile:** Events = 36336

**Tuesday, January 15, 2013=11574, 15 minute drops**

0000	0100	0200	0300	0400	0500	0600	0700	0800	0900	1000	1100	1200	1300	1400	1500	1600	1700	1800	1900	2000	2100	2200	2300	
42	35	47	77	190	608	1424	1875	1145	750	622	572	585	635	596	396	271	580	416	213	165	140	132	58	
11	7	17	7	34	87	253	513	360	220	111	155	126	155	152	136	74	117	119	58	45	39	25	12	7
12	9	10	26	39	145	402	468	322	182	219	140	151	150	140	135	59	195	115	45	37	28	39	12	6
10	7	4	24	57	164	413	446	259	180	142	145	131	172	173	62	82	158	93	63	48	24	29	17	8
9	12	16	20	60	212	356	448	204	168	150	132	177	158	131	63	56	110	89	47	35	49	39	17	18

AM Peak 0700 - 0800 (1875), AM PHF=0.91 PM Peak 1245 - 1345 (654), PM PHF=0.92

**Wednesday, January 16, 2013=12458, 15 minute drops**

0000	0100	0200	0300	0400	0500	0600	0700	0800	0900	1000	1100	1200	1300	1400	1500	1600	1700	1800	1900	2000	2100	2200	2300	
39	34	52	84	197	651	1455	1911	1208	772	660	619	566	581	609	682	536	582	411	262	184	156	120	87	
7	6	15	13	35	95	269	499	332	223	210	137	136	146	139	189	163	163	105	95	52	41	29	14	10
6	11	11	23	49	148	361	462	368	205	175	166	170	140	152	148	110	147	130	62	52	49	32	31	10
8	11	8	27	51	186	413	485	267	162	146	158	129	146	160	178	140	123	104	53	53	37	29	14	4
18	6	18	21	62	222	412	465	241	182	129	158	131	149	158	167	123	149	72	52	27	29	30	28	3

AM Peak 0700 - 0800 (1911), AM PHF=0.96 PM Peak 1500 - 1600 (682), PM PHF=0.90

**Thursday, January 17, 2013=12304, 15 minute drops**

0000	0100	0200	0300	0400	0500	0600	0700	0800	0900	1000	1100	1200	1300	1400	1500	1600	1700	1800	1900	2000	2100	2200	2300	
27	49	49	106	194	619	1346	1920	1257	750	668	602	595	634	614	680	586	526	367	234	146	150	110	75	
10	9	4	21	29	97	238	474	383	196	165	161	164	131	139	220	134	153	97	76	35	37	26	19	17
10	15	15	27	35	132	305	476	378	215	158	131	129	190	164	152	155	120	144	67	43	36	31	27	6
4	17	11	21	60	188	416	501	268	182	195	179	157	159	119	158	166	134	77	42	34	48	23	22	13
3	8	19	37	70	202	387	469	228	157	150	131	145	154	192	150	131	119	49	49	34	29	30	7	11

AM Peak 0700 - 0800 (1920), AM PHF=0.96 PM Peak 1445 - 1545 (722), PM PHF=0.82



# Southern Traffic Services, Inc.

## Event Counts

**US 41 north of Riverview Drive**

**Southbound**

**Datasets:**

**Site:** [081] I6547  
**Input A:** 5 - South bound A>B, North bound B>A. - Added to totals. (1)  
**Input B:** 0 - Unused or unknown. - Excluded from totals. (0)  
**Survey Duration:** 17:26 Monday, January 14, 2013 => 14:45 Friday, January 18, 2013  
**File:** G:\DATA\2013\Private\13015\resets\UM081.eco (Plus)  
**Identifier:** T501XEYX MC56-L5 [MC55] (c)Microcom 19Oct04  
**Algorithm:** Event Count  
**Data type:** Axle sensors - Paired (Class, Speed, Count)

**Profile:**

**Filter time:** 0:00 Tuesday, January 15, 2013 => 0:00 Friday, January 18, 2013  
**Name:** Factory default profile  
**Scheme:** Count events divided by two.  
**Units:** Non metric (ft, mi, ft/s, mph, lb, ton)  
**In profile:** Events = 37577

**Tuesday, January 15, 2013=12316, 15 minute drops**

0000	0100	0200	0300	0400	0500	0600	0700	0800	0900	1000	1100	1200	1300	1400	1500	1600	1700	1800	1900	2000	2100	2200	2300	
99	56	47	55	72	191	342	469	454	454	449	517	556	557	657	1051	1432	1717	1189	653	449	364	291	195	
29	13	9	10	13	29	74	117	58	98	95	127	138	133	181	206	337	408	312	177	124	81	62	54	29
19	12	10	16	16	32	86	122	160	129	108	127	143	147	116	223	320	445	337	129	65	106	79	57	20
26	2	13	15	24	11	92	94	115	73	134	158	125	130	189	276	395	439	298	189	143	100	83	36	13
25	29	15	14	19	119	90	136	121	154	112	105	150	147	171	346	380	425	242	158	117	77	67	48	25

AM Peak 1130 - 1230 (544), AM PHF=0.86 PM Peak 1700 - 1800 (1717), PM PHF=0.96

**Wednesday, January 16, 2013=12604, 15 minute drops**

0000	0100	0200	0300	0400	0500	0600	0700	0800	0900	1000	1100	1200	1300	1400	1500	1600	1700	1800	1900	2000	2100	2200	2300	
87	74	51	58	91	211	409	453	511	353	508	489	617	577	702	1007	1286	1666	1445	676	491	339	314	189	
29	12	13	8	17	12	96	102	150	91	169	142	136	149	148	190	209	424	357	220	118	107	103	62	35
20	23	12	21	28	69	96	107	109	133	105	123	164	133	192	233	339	525	480	131	110	87	86	36	34
13	24	12	14	28	59	108	113	131	97	117	94	171	154	171	244	359	407	356	16	143	18	72	53	31
25	15	14	15	18	71	109	131	121	32	117	130	146	141	191	340	379	310	252	309	120	127	53	38	21

AM Peak 1145 - 1245 (601), AM PHF=0.88 PM Peak 1645 - 1745 (1735), PM PHF=0.83

**Thursday, January 17, 2013=12657, 15 minute drops**

0000	0100	0200	0300	0400	0500	0600	0700	0800	0900	1000	1100	1200	1300	1400	1500	1600	1700	1800	1900	2000	2100	2200	2300	
121	90	56	64	88	180	392	466	526	458	490	452	550	698	758	987	1510	1726	1069	709	398	377	301	191	
35	25	12	15	19	37	77	112	140	131	98	79	128	197	187	215	378	411	366	248	97	93	82	69	38
34	23	16	15	22	25	25	123	142	73	111	154	142	164	195	243	377	488	307	150	52	122	73	42	31
31	22	15	21	22	49	200	114	133	147	149	113	171	176	170	238	368	429	121	180	153	91	75	43	35
21	20	13	13	25	69	90	117	111	107	132	106	109	161	206	291	387	398	275	131	96	71	71	37	23

AM Peak 1145 - 1245 (547), AM PHF=0.80 PM Peak 1700 - 1800 (1726), PM PHF=0.88

# Southern Traffic Services, Inc.

## Event Counts

**US 41 south of Riverview Drive**

**Northbound**

**Datasets:**

**Site:** [082] !C1117  
**Input A:** 1 - North bound, A hit first. - Added to totals. (1)  
**Input B:** 0 - Unused or unknown. - Excluded from totals. (0)  
**Survey Duration:** 13:16 Monday, January 07, 2013 => 19:50 Friday, January 11, 2013  
**File:** G:\DATA\2013\Private\13015\brandon\machine data 1-7-13\UM082 NB.eco (Plus)  
**Identifier:** DA75YESM MC56-L5 [MC55] (c)Microcom 19Oct04  
**Algorithm:** Event Count  
**Data type:** Axle sensors - Paired (Class, Speed, Count)

**Profile:**

**Filter time:** 0:00 Tuesday, January 08, 2013 => 0:00 Friday, January 11, 2013  
**Name:** Factory default profile  
**Scheme:** Count events divided by two.  
**Units:** Non metric (ft, mi, ft/s, mph, lb, ton)  
**In profile:** Events = 43250

**Tuesday, January 08, 2013=14586, 15 minute drops**

0000	0100	0200	0300	0400	0500	0600	0700	0800	0900	1000	1100	1200	1300	1400	1500	1600	1700	1800	1900	2000	2100	2200	2300	
57	47	39	91	197	667	1739	2057	1364	828	767	734	779	755	728	804	694	760	509	291	234	209	147	89	
14	17	15	18	24	108	285	461	402	154	209	177	185	193	150	202	173	187	161	81	56	58	33	18	21
12	15	7	21	42	148	446	585	356	239	186	183	179	189	210	179	181	211	133	77	49	60	45	27	14
13	10	10	28	62	190	485	519	329	227	189	167	217	172	199	215	162	188	118	87	63	47	37	27	17
18	5	7	24	69	221	523	492	277	208	183	207	198	201	169	208	178	174	97	46	66	44	32	17	14

AM Peak 0645 - 0745 (2088), AM PHF=0.89 PM Peak 1500 - 1600 (804), PM PHF=0.93

**Wednesday, January 09, 2013=14379, 15 minute drops**

0000	0100	0200	0300	0400	0500	0600	0700	0800	0900	1000	1100	1200	1300	1400	1500	1600	1700	1800	1900	2000	2100	2200	2300	
66	46	51	99	209	719	1613	1989	1287	810	744	676	725	700	752	780	724	741	587	317	248	233	160	103	
21	10	14	5	31	115	290	469	368	217	193	164	182	188	208	184	186	212	163	104	56	74	50	27	20
14	13	8	31	42	146	426	498	344	201	197	166	168	190	192	167	185	163	165	96	72	72	35	31	20
17	12	15	33	71	207	471	521	296	185	150	177	187	156	179	209	179	191	126	64	67	50	38	18	5
14	11	14	30	65	251	426	501	279	207	204	169	188	166	173	220	174	175	133	53	53	37	37	27	11

AM Peak 0700 - 0800 (1989), AM PHF=0.95 PM Peak 1530 - 1630 (800), PM PHF=0.91

**Thursday, January 10, 2013=14285, 15 minute drops**

0000	0100	0200	0300	0400	0500	0600	0700	0800	0900	1000	1100	1200	1300	1400	1500	1600	1700	1800	1900	2000	2100	2200	2300	
56	52	41	75	203	659	1528	2013	1286	816	712	710	727	738	737	803	735	733	559	345	277	213	175	92	
20	8	9	13	28	111	284	502	392	206	156	184	171	187	179	183	201	186	159	101	61	58	42	34	20
20	8	8	21	37	126	410	508	363	225	203	172	156	158	186	184	178	177	152	104	69	58	51	20	19
5	18	10	24	75	201	356	504	281	204	115	194	208	205	169	244	168	182	127	80	76	48	49	23	7
11	18	14	17	63	221	478	499	250	181	238	160	192	188	203	192	188	188	121	60	71	49	33	15	17

AM Peak 0700 - 0800 (2013), AM PHF=0.99 PM Peak 1515 - 1615 (821), PM PHF=0.84

# Southern Traffic Services, Inc.

## Event Counts

US 41 south of Riverview Drive

Southbound

**Datasets:**

**Site:** [082] I9133  
**Input A:** 3 - South bound, A hit first. - Added to totals. (1)  
**Input B:** 0 - Unused or unknown. - Excluded from totals. (0)  
**Survey Duration:** 14:22 Monday, January 07, 2013 => 19:48 Friday, January 11, 2013  
**File:** G:\DATA\2013\Private\13015\brandon\machine data 1-7-13\UM082 SB.eco (Plus)  
**Identifier:** AQ40B8GK MC56-L5 [MC55] (c)Microcom 19Oct04  
**Algorithm:** Event Count  
**Data type:** Axle sensors - Paired (Class, Speed, Count)

**Profile:**

**Filter time:** 0:00 Tuesday, January 08, 2013 => 0:00 Friday, January 11, 2013  
**Name:** Factory default profile  
**Scheme:** Count events divided by two.  
**Units:** Non metric (ft, mi, ft/s, mph, lb, ton)  
**In profile:** Events = 43321

**Tuesday, January 08, 2013=14372, 15 minute drops**

0000	0100	0200	0300	0400	0500	0600	0700	0800	0900	1000	1100	1200	1300	1400	1500	1600	1700	1800	1900	2000	2100	2200	2300	
185	93	57	88	118	208	412	587	583	550	554	691	661	720	767	1212	1587	1891	1337	702	502	376	295	196	
67	17	12	15	26	33	93	153	154	140	145	142	168	186	183	217	351	468	385	202	127	84	99	44	33
68	37	19	20	29	39	85	143	159	148	135	179	167	103	223	264	361	515	401	164	156	106	76	56	35
31	18	15	29	29	68	127	151	145	127	151	176	162	283	182	378	429	437	294	166	112	75	66	51	20
19	21	11	24	34	68	107	140	125	135	123	194	164	148	179	353	446	471	257	170	107	111	54	45	21

AM Peak 1115 - 1215 (717), AM PHF=0.92 PM Peak 1700 - 1800 (1891), PM PHF=0.92

**Wednesday, January 09, 2013=14455, 15 minute drops**

0000	0100	0200	0300	0400	0500	0600	0700	0800	0900	1000	1100	1200	1300	1400	1500	1600	1700	1800	1900	2000	2100	2200	2300	
109	99	73	57	117	232	433	629	600	545	562	614	704	677	785	1238	1520	1899	1363	673	503	434	347	242	
33	28	23	13	20	25	99	141	131	132	133	160	227	172	181	252	344	476	428	203	143	107	98	65	35
35	27	31	19	29	46	98	145	177	151	141	173	140	177	192	255	400	562	371	109	130	93	93	38	53
20	22	13	17	32	71	120	184	155	100	129	188	167	179	211	362	406	449	288	233	113	133	83	83	31
21	22	6	8	36	90	116	159	137	162	159	93	170	149	201	369	370	412	276	128	117	101	73	56	29

AM Peak 1115 - 1215 (681), AM PHF=0.75 PM Peak 1700 - 1800 (1899), PM PHF=0.84

**Thursday, January 10, 2013=14494, 15 minute drops**

0000	0100	0200	0300	0400	0500	0600	0700	0800	0900	1000	1100	1200	1300	1400	1500	1600	1700	1800	1900	2000	2100	2200	2300	
148	104	73	63	106	208	429	620	498	568	602	622	715	666	815	1224	1559	1873	1323	753	557	393	342	233	
35	30	21	18	23	36	98	153	102	187	153	152	181	143	178	257	357	458	351	228	147	101	78	15	44
53	26	14	15	24	43	121	148	155	130	118	158	186	171	216	310	377	485	349	222	153	121	91	117	53
31	27	19	16	33	59	111	174	146	120	151	150	193	109	194	291	397	480	331	167	139	93	95	59	36
29	21	19	14	26	70	99	145	95	131	180	162	155	243	227	366	428	450	292	136	118	78	78	42	30

AM Peak 1145 - 1245 (722), AM PHF=0.94 PM Peak 1700 - 1800 (1873), PM PHF=0.97

# Southern Traffic Services, Inc.

## Event Counts

**Riverview Drive east of US 41**

**Eastbound**

**Datasets:**

**Site:** [083] !C1134  
**Input A:** 8 - East bound A>B, West bound B>A. - Added to totals. (1)  
**Input B:** 0 - Unused or unknown. - Subtracted from totals. (-1)  
**Survey Duration:** 14:21 Monday, January 07, 2013 => 19:58 Friday, January 11, 2013  
**File:** G:\DATA\2013\Private\13015\brandon\machine data 1-7-13\UM083.eco (Plus)  
**Identifier:** DB379CAP MC56-L5 [MC55] (c)Microcom 19Oct04  
**Algorithm:** Event Count  
**Data type:** Axle sensors - Paired (Class, Speed, Count)

**Profile:**

**Filter time:** 0:00 Tuesday, January 08, 2013 => 0:00 Friday, January 11, 2013  
**Name:** Factory default profile  
**Scheme:** Count events divided by two.  
**Units:** Non metric (ft, mi, ft/s, mph, lb, ton)  
**In profile:** Events = 9918

**Tuesday, January 08, 2013=3277, 15 minute drops**

	0000	0100	0200	0300	0400	0500	0600	0700	0800	0900	1000	1100	1200	1300	1400	1500	1600	1700	1800	1900	2000	2100	2200	2300
	25	8	13	11	19	45	181	220	151	150	156	160	185	172	211	295	308	369	206	128	93	73	64	34
12	3	6	3	2	6	23	60	33	26	41	44	50	35	46	62	75	111	60	39	22	22	18	5	
5	3	4	2	2	7	24	71	40	29	33	29	45	42	67	54	71	102	47	38	23	21	19	12	
4	1	3	2	8	13	71	40	44	46	46	29	54	61	61	87	65	75	55	30	18	16	10	7	
4	1	0	4	7	19	63	49	34	49	36	58	36	34	37	92	97	81	44	21	30	14	17	10	

AM Peak 0630 - 0730 (265), AM PHF=0.93 PM Peak 1645 - 1745 (385), PM PHF=0.87

**Wednesday, January 09, 2013=3251, 15 minute drops**

	0000	0100	0200	0300	0400	0500	0600	0700	0800	0900	1000	1100	1200	1300	1400	1500	1600	1700	1800	1900	2000	2100	2200	2300
	11	11	8	9	14	33	119	235	147	143	170	160	186	181	233	309	292	343	246	127	112	65	50	47
1	1	2	0	2	4	14	65	43	26	35	32	73	42	71	86	66	95	68	53	29	21	12	10	
4	3	2	6	0	9	18	61	31	42	56	33	27	50	57	53	77	96	66	20	31	15	15	16	
2	5	2	2	8	14	36	50	39	36	41	52	40	47	57	77	74	76	53	29	33	16	12	8	
4	2	2	1	4	6	51	59	34	39	38	43	46	42	48	93	75	76	59	25	19	13	11	13	

AM Peak 0700 - 0800 (235), AM PHF=0.90 PM Peak 1700 - 1800 (343), PM PHF=0.89

**Thursday, January 10, 2013=3390, 15 minute drops**

	0000	0100	0200	0300	0400	0500	0600	0700	0800	0900	1000	1100	1200	1300	1400	1500	1600	1700	1800	1900	2000	2100	2200	2300
	17	14	11	4	12	35	112	201	153	127	157	211	184	179	242	339	311	337	274	174	111	71	71	43
5	2	6	1	0	4	16	58	38	38	47	63	50	60	58	78	66	88	69	60	19	20	18	14	
7	6	2	0	5	6	17	51	36	24	35	45	35	32	55	68	94	77	72	45	30	18	16	13	
2	4	1	0	4	15	22	39	36	35	32	55	56	33	51	87	58	76	69	43	27	20	22	9	
3	2	2	3	3	10	57	53	43	30	43	48	43	54	78	106	93	96	64	26	35	13	15	7	

AM Peak 1100 - 1200 (211), AM PHF=0.84 PM Peak 1530 - 1630 (353), PM PHF=0.83

# Southern Traffic Services, Inc.

## Event Counts

**Riverview Drive east of US 41**

**Westbound**

**Datasets:**

**Site:** [083] !C1134  
**Input A:** 8 - East bound A>B, West bound B>A. - Excluded from totals. (0)  
**Input B:** 0 - Unused or unknown. - Added to totals. (1)  
**Survey Duration:** 14:21 Monday, January 07, 2013 => 19:58 Friday, January 11, 2013  
**File:** G:\DATA\2013\Private\13015\brandon\machine data 1-7-13\UM083.eco (Plus)  
**Identifier:** DB379CAP MC56-L5 [MC55] (c)Microcom 19Oct04  
**Algorithm:** Event Count  
**Data type:** Axle sensors - Paired (Class, Speed, Count)

**Profile:**

**Filter time:** 0:00 Tuesday, January 08, 2013 => 0:00 Friday, January 11, 2013  
**Name:** Factory default profile  
**Scheme:** Count events divided by two.  
**Units:** Non metric (ft, mi, ft/s, mph, lb, ton)  
**In profile:** Events = 8990

**Tuesday, January 08, 2013=2920, 15 minute drops**

0000	0100	0200	0300	0400	0500	0600	0700	0800	0900	1000	1100	1200	1300	1400	1500	1600	1700	1800	1900	2000	2100	2200	2300	
21	10	4	23	25	89	207	283	189	152	155	136	176	176	148	182	226	248	182	88	66	65	50	19	
7	3	1	5	6	16	26	69	44	42	35	29	37	50	35	41	54	73	52	28	17	17	13	3	3
7	2	1	9	4	14	48	70	60	43	39	33	45	52	28	45	37	61	48	22	15	12	21	7	6
5	2	0	6	7	26	76	81	41	40	53	37	46	40	45	50	78	46	50	19	24	25	10	3	4
2	3	2	3	8	33	57	63	44	27	28	37	48	34	40	46	57	68	32	19	10	11	6	6	3

AM Peak 0700 - 0800 (283), AM PHF=0.87 PM Peak 1630 - 1730 (269), PM PHF=0.86

**Wednesday, January 09, 2013=3005, 15 minute drops**

0000	0100	0200	0300	0400	0500	0600	0700	0800	0900	1000	1100	1200	1300	1400	1500	1600	1700	1800	1900	2000	2100	2200	2300	
16	8	9	19	23	73	227	278	195	145	146	140	154	177	174	219	203	258	204	127	67	66	56	21	
3	2	4	3	3	10	30	58	54	31	34	32	48	34	50	47	43	66	34	38	18	17	9	7	8
6	1	0	5	5	13	60	76	54	44	39	33	35	39	30	58	47	77	79	42	16	15	20	4	3
4	1	4	5	5	28	63	80	38	36	38	35	39	56	57	61	66	52	51	24	15	20	13	7	4
3	4	1	6	10	22	74	64	49	34	35	40	32	48	37	53	47	63	40	23	18	14	14	3	3

AM Peak 0645 - 0745 (288), AM PHF=0.90 PM Peak 1700 - 1800 (258), PM PHF=0.84

**Thursday, January 10, 2013=3065, 15 minute drops**

0000	0100	0200	0300	0400	0500	0600	0700	0800	0900	1000	1100	1200	1300	1400	1500	1600	1700	1800	1900	2000	2100	2200	2300	
18	11	11	17	21	70	216	249	199	137	147	162	172	189	156	214	212	261	219	115	110	74	56	29	
8	3	4	6	2	8	28	56	55	35	43	47	52	48	28	49	50	70	73	32	27	15	14	12	13
3	5	0	5	2	11	47	66	36	39	36	41	35	37	33	55	62	76	50	35	26	24	14	8	14
4	0	5	3	10	22	64	74	65	31	35	40	44	53	51	56	52	54	53	24	33	22	16	5	8
3	3	2	3	7	29	77	53	43	32	33	34	41	51	44	54	48	61	43	24	24	13	12	4	4

AM Peak 0645 - 0745 (273), AM PHF=0.89 PM Peak 1715 - 1815 (264), PM PHF=0.87

# Southern Traffic Services, Inc.

## Event Counts

**Industrial Access Road west of US 41**

**Eastbound**

**Datasets:**

**Site:** [084] !C.XUZ  
**Input A:** 2 - East bound, A hit first. - Added to totals. (1)  
**Input B:** 0 - Unused or unknown. - Excluded from totals. (0)  
**Survey Duration:** 10:18 Monday, January 07, 2013 => 19:39 Friday, January 11, 2013  
**File:** G:\DATA\2013\Private\13015\brandon\machine data 1-7-13\UM084 EB.eco (Plus)  
**Identifier:** 13851108 MC56-6 [MC55] (c)Microcom 02/03/01  
**Algorithm:** Event Count  
**Data type:** Axle sensors - Paired (Class, Speed, Count)

**Profile:**

**Filter time:** 0:00 Tuesday, January 08, 2013 => 0:00 Friday, January 11, 2013  
**Name:** Factory default profile  
**Scheme:** Count events divided by two.  
**Units:** Non metric (ft, mi, ft/s, mph, lb, ton)  
**In profile:** Events = 2317

**Tuesday, January 08, 2013=774, 15 minute drops**

0000	0100	0200	0300	0400	0500	0600	0700	0800	0900	1000	1100	1200	1300	1400	1500	1600	1700	1800	1900	2000	2100	2200	2300	
1	2	5	1	6	10	34	36	28	39	20	60	62	52	33	124	85	75	51	33	4	3	8	2	
0	0	3	0	3	0	3	14	8	9	6	12	21	15	7	42	18	24	12	15	1	0	4	2	0
0	2	0	0	0	3	7	9	6	12	4	13	11	13	5	25	16	21	9	6	0	0	0	0	1
1	0	2	0	3	1	2	7	10	9	6	23	11	10	10	40	25	17	6	11	1	0	2	0	1
0	0	0	1	0	6	22	6	4	9	4	12	19	14	11	17	26	13	24	1	2	3	2	0	0

AM Peak 1115 - 1215 (69), AM PHF=0.75 PM Peak 1500 - 1600 (124), PM PHF=0.74

**Wednesday, January 09, 2013=758, 15 minute drops**

0000	0100	0200	0300	0400	0500	0600	0700	0800	0900	1000	1100	1200	1300	1400	1500	1600	1700	1800	1900	2000	2100	2200	2300	
2	5	1	1	13	10	45	37	22	20	20	88	36	27	39	129	86	80	53	26	3	5	7	3	
0	4	0	0	0	5	9	13	6	7	5	9	16	4	15	45	16	20	12	14	1	0	0	1	1
1	1	0	0	5	1	2	9	7	5	8	14	12	9	9	26	26	34	4	6	0	0	4	1	1
1	0	1	1	5	1	13	11	5	4	2	46	3	5	8	38	18	14	9	4	1	1	0	1	0
0	0	0	0	3	3	21	4	4	4	5	19	5	9	7	20	26	12	28	2	1	4	3	0	0

AM Peak 1115 - 1215 (95), AM PHF=0.52 PM Peak 1500 - 1600 (129), PM PHF=0.72

**Thursday, January 10, 2013=785, 15 minute drops**

0000	0100	0200	0300	0400	0500	0600	0700	0800	0900	1000	1100	1200	1300	1400	1500	1600	1700	1800	1900	2000	2100	2200	2300	
2	4	3	0	5	16	40	31	27	26	44	66	51	32	38	135	92	74	44	26	11	9	3	6	
1	0	0	0	1	1	4	12	8	9	12	9	19	9	15	53	29	34	8	17	4	1	0	3	0
1	2	0	0	1	5	9	6	6	5	9	35	11	10	10	34	29	19	10	2	2	1	0	0	0
0	2	3	0	0	1	7	8	3	6	10	11	17	7	6	30	15	12	4	5	4	1	1	3	0
0	0	0	0	3	9	20	5	10	6	13	11	4	6	7	18	19	9	22	2	1	6	2	0	0

AM Peak 1115 - 1215 (76), AM PHF=0.54 PM Peak 1500 - 1600 (135), PM PHF=0.64

# Southern Traffic Services, Inc.

## Event Counts

**Industrial Access Road west of US 41**

**Westbound**

**Datasets:**

**Site:** [084] I9012  
**Input A:** 4 - West bound, A hit first. - Added to totals. (1)  
**Input B:** 0 - Unused or unknown. - Excluded from totals. (0)  
**Survey Duration:** 14:21 Monday, January 07, 2013 => 19:56 Friday, January 11, 2013  
**File:** G:\DATA\2013\Private\13015\brandon\machine data 1-7-13\UM084 WB.eco (Plus)  
**Identifier:** AQ842WKB MC56-L5 [MC55] (c)Microcom 19Oct04  
**Algorithm:** Event Count  
**Data type:** Axle sensors - Paired (Class, Speed, Count)

**Profile:**

**Filter time:** 0:00 Tuesday, January 08, 2013 => 0:00 Friday, January 11, 2013  
**Name:** Factory default profile  
**Scheme:** Count events divided by two.  
**Units:** Non metric (ft, mi, ft/s, mph, lb, ton)  
**In profile:** Events = 2412

**Tuesday, January 08, 2013=826, 15 minute drops**

0000	0100	0200	0300	0400	0500	0600	0700	0800	0900	1000	1100	1200	1300	1400	1500	1600	1700	1800	1900	2000	2100	2200	2300	
3	5	1	0	12	68	203	90	92	31	36	31	70	57	20	23	11	11	41	1	3	15	1	1	0
0	2	0	0	3	6	28	28	31	4	4	6	14	22	10	5	0	2	8	1	0	12	0	0	0
1	2	1	0	4	9	70	11	26	6	15	6	9	17	1	4	1	2	16	0	2	0	0	0	5
0	0	0	0	2	24	64	21	12	18	5	7	17	9	2	13	1	2	14	0	1	2	1	1	1
2	1	0	0	3	29	41	30	23	3	12	12	30	9	7	1	9	5	3	0	0	1	0	0	0

AM Peak 0600 - 0700 (203), AM PHF=0.72 PM Peak 1230 - 1330 (86), PM PHF=0.72

**Wednesday, January 09, 2013=762, 15 minute drops**

0000	0100	0200	0300	0400	0500	0600	0700	0800	0900	1000	1100	1200	1300	1400	1500	1600	1700	1800	1900	2000	2100	2200	2300	
6	3	2	15	8	69	194	74	80	30	19	31	55	46	19	16	17	16	44	4	3	6	2	3	0
0	3	0	0	6	3	29	20	22	9	4	3	7	20	11	1	7	5	13	3	0	0	0	0	0
5	0	0	0	0	18	52	17	23	16	1	14	8	6	0	1	3	0	16	0	1	3	0	0	3
1	0	2	8	1	17	60	14	18	3	9	5	24	11	0	12	5	5	12	0	1	1	0	1	0
0	0	0	7	1	31	53	23	17	2	5	9	16	9	8	2	2	6	3	1	1	2	2	2	1

AM Peak 0600 - 0700 (194), AM PHF=0.81 PM Peak 1215 - 1315 (68), PM PHF=0.71

**Thursday, January 10, 2013=824, 15 minute drops**

0000	0100	0200	0300	0400	0500	0600	0700	0800	0900	1000	1100	1200	1300	1400	1500	1600	1700	1800	1900	2000	2100	2200	2300	
4	6	0	4	7	49	195	87	99	47	30	13	79	47	13	20	33	33	41	2	4	9	2	0	4
0	0	0	0	1	1	37	23	25	11	3	1	11	19	5	5	6	5	9	1	0	2	1	0	0
3	0	0	0	1	6	53	17	24	8	4	7	12	7	3	0	10	4	18	0	0	1	0	0	0
0	2	0	2	3	16	59	21	28	4	6	2	23	7	1	10	10	9	13	0	1	3	1	0	0
1	4	0	2	2	26	46	26	22	24	17	3	33	14	4	5	7	15	1	1	3	3	0	0	1

AM Peak 0600 - 0700 (195), AM PHF=0.83 PM Peak 1215 - 1315 (87), PM PHF=0.66



# Southern Traffic Services, Inc.

2911 Westfield Rd  
Gulf Breeze, FL 32563  
1-800-786-3374

*Traffic is our only business!*

US 41 @ Madison Ave  
Tampa, FL

File Name : 13015-9 US 41 @ Madison Ave  
Site Code : 13015-9  
Start Date : 1/8/2013  
Page No : 1

Groups Printed- Automobiles - Trucks - Buses

Start Time	US 41 Southbound				MADISON AVE Westbound				US 41 Northbound				PENDOLA PT Eastbound				Int. Total
	Left	Thru	Right	U-Turns	Left	Thru	Right	U-Turns	Left	Thru	Right	U-Turns	Left	Thru	Right	U-Turns	
07:00 AM	31	87	6	0	14	4	91	0	3	482	11	0	9	1	1	0	740
07:15 AM	52	94	7	0	13	5	96	0	2	461	15	1	4	1	1	0	752
07:30 AM	30	103	5	0	10	1	91	0	6	437	11	0	7	0	1	0	702
07:45 AM	39	117	10	0	13	2	69	0	2	476	21	0	3	2	6	0	760
<b>Total</b>	<b>152</b>	<b>401</b>	<b>28</b>	<b>0</b>	<b>50</b>	<b>12</b>	<b>347</b>	<b>0</b>	<b>13</b>	<b>1856</b>	<b>58</b>	<b>1</b>	<b>23</b>	<b>4</b>	<b>9</b>	<b>0</b>	<b>2954</b>
08:00 AM	46	129	9	0	16	4	79	0	3	337	17	0	4	4	2	0	650
08:15 AM	53	122	8	2	15	0	68	1	2	268	18	0	2	2	1	0	562
08:30 AM	33	118	2	0	11	2	51	0	3	293	4	0	4	3	2	0	526
08:45 AM	30	92	12	0	9	4	42	0	1	220	2	0	4	5	1	0	422
<b>Total</b>	<b>162</b>	<b>461</b>	<b>31</b>	<b>2</b>	<b>51</b>	<b>10</b>	<b>240</b>	<b>1</b>	<b>9</b>	<b>1118</b>	<b>41</b>	<b>0</b>	<b>14</b>	<b>14</b>	<b>6</b>	<b>0</b>	<b>2160</b>
<b>**BREAK**</b>																	
04:00 PM	70	311	3	0	14	1	37	1	0	133	14	0	4	1	1	0	590
04:15 PM	67	349	3	0	11	2	44	1	0	130	12	0	5	2	2	0	628
04:30 PM	93	378	2	1	17	0	43	2	0	133	11	0	8	3	2	0	693
04:45 PM	97	380	2	0	19	0	25	6	1	139	4	0	8	2	2	0	685
<b>Total</b>	<b>327</b>	<b>1418</b>	<b>10</b>	<b>1</b>	<b>61</b>	<b>3</b>	<b>149</b>	<b>10</b>	<b>1</b>	<b>535</b>	<b>41</b>	<b>0</b>	<b>25</b>	<b>8</b>	<b>7</b>	<b>0</b>	<b>2596</b>
05:00 PM	94	413	2	0	13	0	49	5	0	130	4	0	4	4	0	0	718
05:15 PM	123	479	0	1	15	0	27	1	0	132	11	0	5	1	0	0	795
05:30 PM	90	405	1	0	13	0	38	4	0	139	9	0	2	2	0	0	703
05:45 PM	101	409	2	0	13	0	35	0	0	130	18	0	2	1	0	0	711
<b>Total</b>	<b>408</b>	<b>1706</b>	<b>5</b>	<b>1</b>	<b>54</b>	<b>0</b>	<b>149</b>	<b>10</b>	<b>0</b>	<b>531</b>	<b>42</b>	<b>0</b>	<b>13</b>	<b>8</b>	<b>0</b>	<b>0</b>	<b>2927</b>
<b>Grand Total</b>	<b>1049</b>	<b>3986</b>	<b>74</b>	<b>4</b>	<b>216</b>	<b>25</b>	<b>885</b>	<b>21</b>	<b>23</b>	<b>4040</b>	<b>182</b>	<b>1</b>	<b>75</b>	<b>34</b>	<b>22</b>	<b>0</b>	<b>10637</b>
Apprch %	20.5	78	1.4	0.1	18.8	2.2	77.2	1.8	0.5	95.1	4.3	0	57.3	26	16.8	0	
Total %	9.9	37.5	0.7	0	2	0.2	8.3	0.2	0.2	38	1.7	0	0.7	0.3	0.2	0	
Automobiles	969	3740	24	4	195	16	787	21	4	3843	157	1	44	15	5	0	9825
% Automobiles	92.4	93.8	32.4	100	90.3	64	88.9	100	17.4	95.1	86.3	100	58.7	44.1	22.7	0	92.4
Trucks	79	240	50	0	21	9	97	0	19	196	23	0	31	19	17	0	801
% Trucks	7.5	6	67.6	0	9.7	36	11	0	82.6	4.9	12.6	0	41.3	55.9	77.3	0	7.5
Buses	1	6	0	0	0	0	1	0	0	1	2	0	0	0	0	0	11
% Buses	0.1	0.2	0	0	0	0	0.1	0	0	0	1.1	0	0	0	0	0	0.1





# Southern Traffic Services, Inc.

2911 Westfield Rd  
 Gulf Breeze, FL 32563  
 1-800-786-3374

*Traffic is our only business!*

US 41 @ Madison Ave  
 Tampa, FL

File Name : 13015-9 US 41 @ Madison Ave  
 Site Code : 13015-9  
 Start Date : 1/8/2013  
 Page No : 2

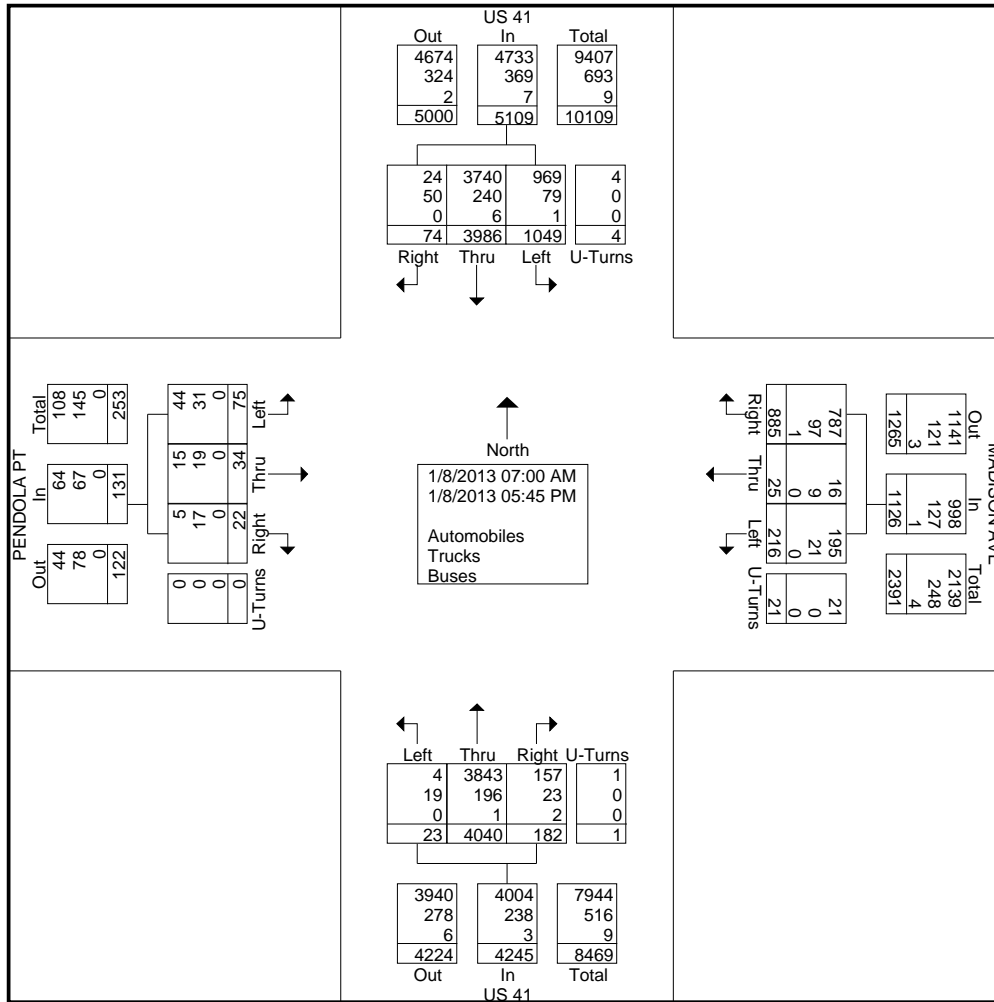



# Southern Traffic Services, Inc.

2911 Westfield Rd  
Gulf Breeze, FL 32563  
1-800-786-3374

*Traffic is our only business!*

US 41 @ Madison Ave  
Tampa, FL

File Name : 13015-9 US 41 @ Madison Ave  
Site Code : 13015-9  
Start Date : 1/8/2013  
Page No : 3

Start Time	US 41 Southbound				MADISON AVE Westbound				US 41 Northbound				PENDOLA PT Eastbound				Int. Total				
	Thru	Right	U-Turns	App. Total	Left	Thru	Right	U-Turns	App. Total	Left	Thru	Right	U-Turns	App. Total	Left	Thru		Right	U-Turns	App. Total	
Peak Hour Analysis From 07:00 AM to 11:45 AM - Peak 1 of 1																					
Peak Hour for Entire Intersection Begins at 07:00 AM																					
07:00 AM	31	87	6	0	124	14	4	91	0	109	3	482	11	0	496	9	1	1	0	11	740
07:15 AM	52	94	7	0	153	13	5	96	0	114	2	461	15	1	479	4	1	1	0	6	752
07:30 AM	30	103	5	0	138	10	1	91	0	102	6	437	11	0	454	7	0	1	0	8	702
07:45 AM	39	117	10	0	166	13	2	69	0	84	2	476	21	0	499	3	2	6	0	11	760
Total Volume	152	401	28	0	581	50	12	347	0	409	13	1856	58	1	1928	23	4	9	0	36	2954
% App. Total	26.2	69	4.8	0		12.2	2.9	84.8	0		0.7	96.3	3	0.1		63.9	11.1	25	0		
PHF	.731	.857	.700	.000	.875	.893	.600	.904	.000	.897	.542	.963	.690	.250	.966	.639	.500	.375	.000	.818	.972
Automobiles	134	335	10	0	479	42	7	320	0	369	2	1814	44	1	1861	12	2	2	0	16	2725
% Automobiles	88.2	83.5	35.7	0	82.4	84.0	58.3	92.2	0	90.2	15.4	97.7	75.9	100	96.5	52.2	50.0	22.2	0	44.4	92.2
Trucks	18	62	18	0	98	8	5	26	0	39	11	42	13	0	66	11	2	7	0	20	223
% Trucks	11.8	15.5	64.3	0	16.9	16.0	41.7	7.5	0	9.5	84.6	2.3	22.4	0	3.4	47.8	50.0	77.8	0	55.6	7.5
Buses	0	4	0	0	4	0	0	1	0	1	0	0	1	0	1	0	0	0	0	0	6
% Buses	0	1.0	0	0	0.7	0	0	0.3	0	0.2	0	0	1.7	0	0.1	0	0	0	0	0	0.2

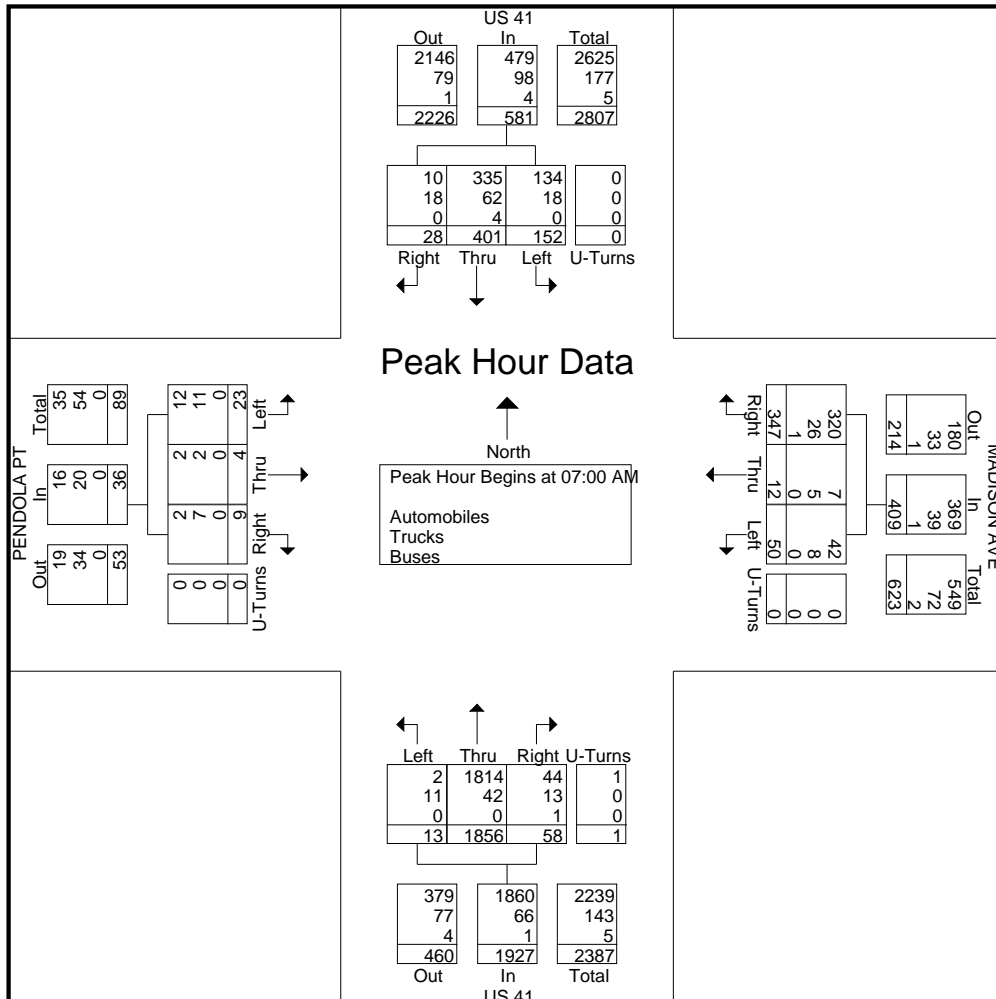



# Southern Traffic Services, Inc.

2911 Westfield Rd  
Gulf Breeze, FL 32563  
1-800-786-3374

*Traffic is our only business!*

US 41 @ Madison Ave  
Tampa, FL

File Name : 13015-9 US 41 @ Madison Ave  
Site Code : 13015-9  
Start Date : 1/8/2013  
Page No : 4

Start Time	US 41 Southbound					MADISON AVE Westbound					US 41 Northbound					PENDOLA PT Eastbound					Int. Total
	Left	Thru	Right	U-Turns	App. Total	Left	Thru	Right	U-Turns	App. Total	Left	Thru	Right	U-Turns	App. Total	Left	Thru	Right	U-Turns	App. Total	

Peak Hour Analysis From 12:00 PM to 05:45 PM - Peak 1 of 1  
Peak Hour for Entire Intersection Begins at 05:00 PM

05:00 PM	94	413	2	0	509	13	0	49	5	67	0	130	4	0	134	4	4	0	0	8	718
05:15 PM	123	479	0	1	603	15	0	27	1	43	0	132	11	0	143	5	1	0	0	6	795
05:30 PM	90	405	1	0	496	13	0	38	4	55	0	139	9	0	148	2	2	0	0	4	703
05:45 PM	101	409	2	0	512	13	0	35	0	48	0	130	18	0	148	2	1	0	0	3	711
Total Volume	408	1706	5	1	2120	54	0	149	10	213	0	531	42	0	573	13	8	0	0	21	2927
% App. Total	19.2	80.5	0.2	0		25.4	0	70	4.7		0	92.7	7.3	0		61.9	38.1	0	0		
PHF	.829	.890	.625	.250	.879	.900	.000	.760	.500	.795	.000	.955	.583	.000	.968	.650	.500	.000	.000	.656	.920
Automobiles	395	1670	2	1	2068	49	0	135	10	194	0	498	39	0	537	12	6	0	0	18	2817
% Automobiles	96.8	97.9	40.0	100	97.5	90.7	0	90.6	100	91.1	0	93.8	92.9	0	93.7	92.3	75.0	0	0	85.7	96.2
Trucks	12	35	3	0	50	5	0	14	0	19	0	32	3	0	35	1	2	0	0	3	107
% Trucks	2.9	2.1	60.0	0	2.4	9.3	0	9.4	0	8.9	0	6.0	7.1	0	6.1	7.7	25.0	0	0	14.3	3.7
Buses	1	1	0	0	2	0	0	0	0	0	0	1	0	0	1	0	0	0	0	0	3
% Buses	0.2	0.1	0	0	0.1	0	0	0	0	0	0	0.2	0	0	0.2	0	0	0	0	0	0.1

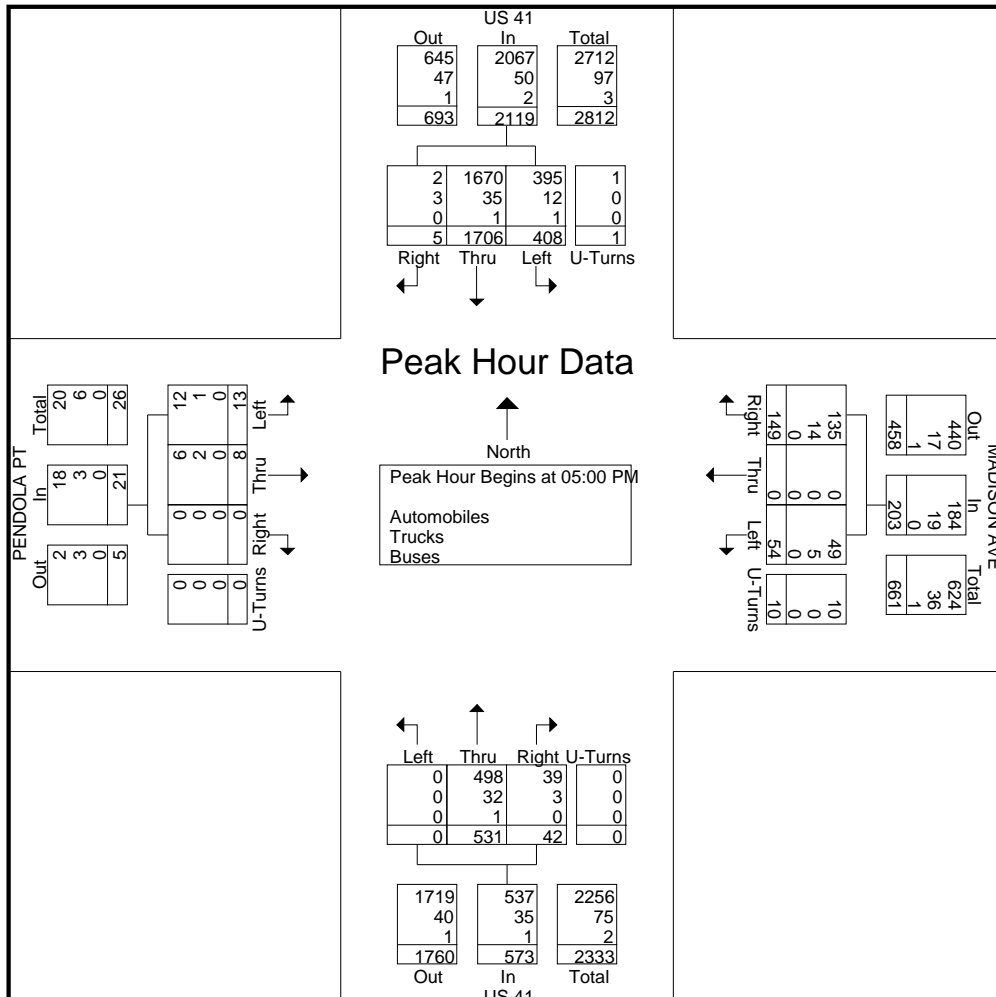



# Southern Traffic Services, Inc.

2911 Westfield Rd  
Gulf Breeze, FL 32563  
1-800-786-3374

*Traffic is our only business!*

US 41 @ Madison Ave  
Tampa, FL

File Name : 13015-9 US 41 @ Madison Ave  
Site Code : 13015-9  
Start Date : 1/8/2013  
Page No : 1

Groups Printed- Automobiles

Start Time	US 41 Southbound				MADISON AVE Westbound				US 41 Northbound				PENDOLA PT Eastbound				Int. Total
	Left	Thru	Right	U-Turns	Left	Thru	Right	U-Turns	Left	Thru	Right	U-Turns	Left	Thru	Right	U-Turns	
07:00 AM	27	77	3	0	10	4	84	0	0	473	10	0	6	1	1	0	696
07:15 AM	44	71	2	0	12	2	91	0	1	458	9	1	2	1	0	0	694
07:30 AM	28	86	2	0	8	0	81	0	1	424	8	0	3	0	0	0	641
07:45 AM	35	101	3	0	12	1	64	0	0	459	17	0	1	0	1	0	694
Total	134	335	10	0	42	7	320	0	2	1814	44	1	12	2	2	0	2725
08:00 AM	38	100	5	0	15	2	68	0	1	326	17	0	2	0	0	0	574
08:15 AM	47	99	1	2	14	0	63	1	0	244	16	0	0	1	0	0	488
08:30 AM	26	99	1	0	10	2	43	0	1	275	3	0	1	1	0	0	462
08:45 AM	26	67	3	0	9	4	31	0	0	203	1	0	0	2	0	0	346
Total	137	365	10	2	48	8	205	1	2	1048	37	0	3	4	0	0	1870
<b>**BREAK**</b>																	
04:00 PM	61	294	0	0	13	0	32	1	0	115	13	0	1	0	1	0	531
04:15 PM	58	337	1	0	10	1	37	1	0	120	10	0	2	1	2	0	580
04:30 PM	91	370	1	1	17	0	37	2	0	116	10	0	7	1	0	0	653
04:45 PM	93	369	0	0	16	0	21	6	0	132	4	0	7	1	0	0	649
Total	303	1370	2	1	56	1	127	10	0	483	37	0	17	3	3	0	2413
05:00 PM	92	402	2	0	13	0	44	5	0	122	4	0	3	3	0	0	690
05:15 PM	117	469	0	1	13	0	26	1	0	123	9	0	5	1	0	0	765
05:30 PM	89	395	0	0	13	0	34	4	0	132	9	0	2	2	0	0	680
05:45 PM	97	404	0	0	10	0	31	0	0	121	17	0	2	0	0	0	682
Total	395	1670	2	1	49	0	135	10	0	498	39	0	12	6	0	0	2817
Grand Total	969	3740	24	4	195	16	787	21	4	3843	157	1	44	15	5	0	9825
Apprch %	20.5	79	0.5	0.1	19.1	1.6	77.2	2.1	0.1	96	3.9	0	68.8	23.4	7.8	0	
Total %	9.9	38.1	0.2	0	2	0.2	8	0.2	0	39.1	1.6	0	0.4	0.2	0.1	0	



# Southern Traffic Services, Inc.

2911 Westfield Rd  
Gulf Breeze, FL 32563  
1-800-786-3374

*Traffic is our only business!*

US 41 @ Madison Ave  
Tampa, FL

File Name : 13015-9 US 41 @ Madison Ave  
Site Code : 13015-9  
Start Date : 1/8/2013  
Page No : 2

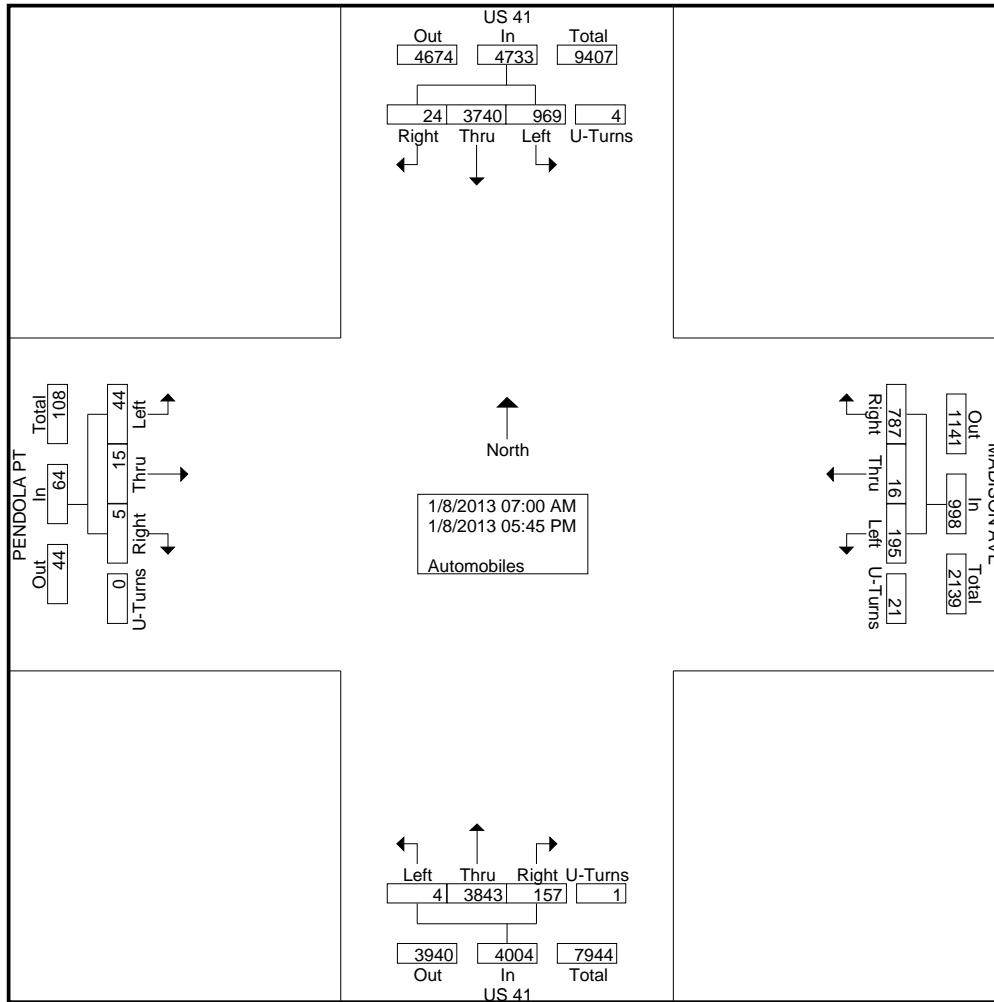



# Southern Traffic Services, Inc.

2911 Westfield Rd  
 Gulf Breeze, FL 32563  
 1-800-786-3374

*Traffic is our only business!*

US 41 @ Madison Ave  
 Tampa, FL

File Name : 13015-9 US 41 @ Madison Ave  
 Site Code : 13015-9  
 Start Date : 1/8/2013  
 Page No : 3

Start Time	US 41 Southbound				MADISON AVE Westbound				US 41 Northbound				PENDOLA PT Eastbound				Int. Total				
	Thru	Right	U-Turns	App. Total	Left	Thru	Right	U-Turns	App. Total	Left	Thru	Right	U-Turns	App. Total	Left	Thru		Right	U-Turns	App. Total	
Peak Hour Analysis From 07:00 AM to 11:45 AM - Peak 1 of 1																					
Peak Hour for Entire Intersection Begins at 07:00 AM																					
07:00 AM	27	77	3	0	107	10	4	84	0	98	0	473	10	0	483	6	1	1	0	8	696
07:15 AM	44	71	2	0	117	12	2	91	0	105	1	458	9	1	469	2	1	0	0	3	694
07:30 AM	28	86	2	0	116	8	0	81	0	89	1	424	8	0	433	3	0	0	0	3	641
07:45 AM	35	101	3	0	139	12	1	64	0	77	0	459	17	0	476	1	0	1	0	2	694
Total Volume	134	335	10	0	479	42	7	320	0	369	2	1814	44	1	1861	12	2	2	0	16	2725
% App. Total	28	69.9	2.1	0		11.4	1.9	86.7	0		0.1	97.5	2.4	0.1		75	12.5	12.5	0		
PHF	.761	.829	.833	.000	.862	.875	.438	.879	.000	.879	.500	.959	.647	.250	.963	.500	.500	.500	.000	.500	.979

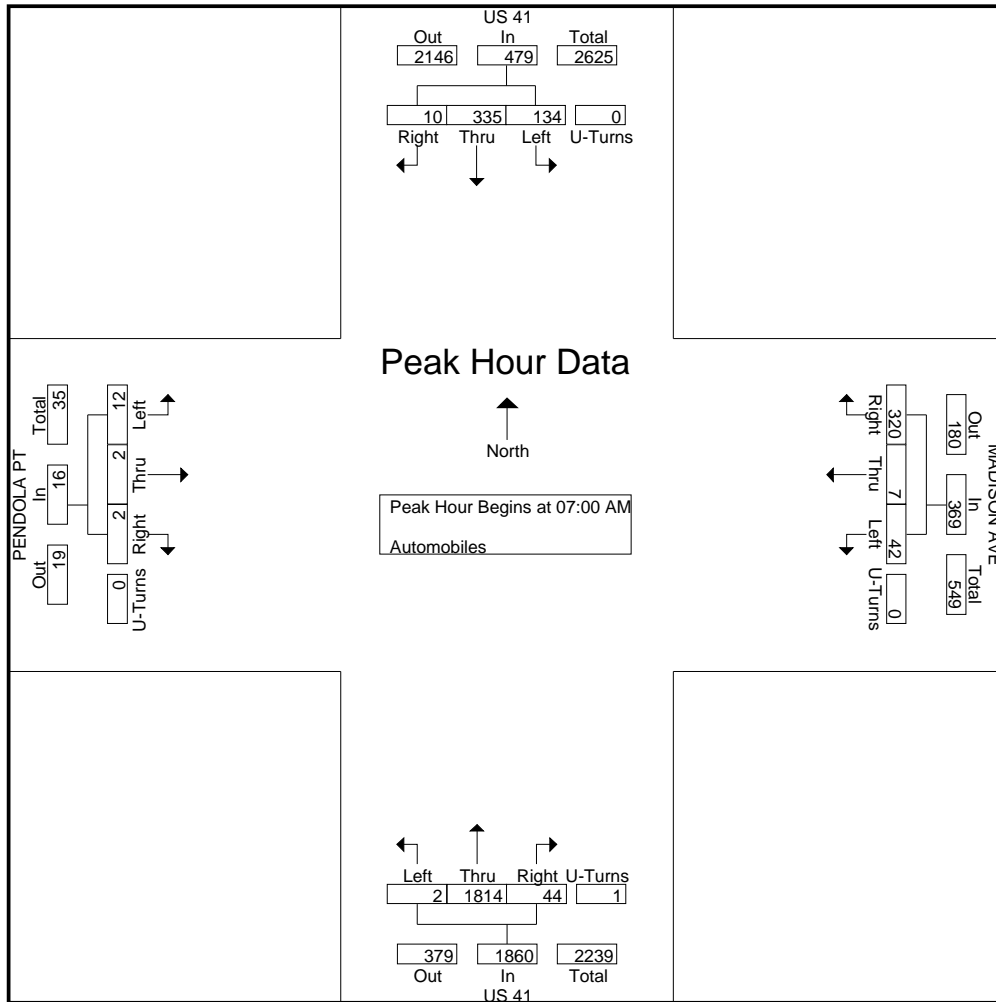



# Southern Traffic Services, Inc.

2911 Westfield Rd  
Gulf Breeze, FL 32563  
1-800-786-3374

*Traffic is our only business!*

US 41 @ Madison Ave  
Tampa, FL

File Name : 13015-9 US 41 @ Madison Ave  
Site Code : 13015-9  
Start Date : 1/8/2013  
Page No : 4

Start Time	US 41 Southbound					MADISON AVE Westbound					US 41 Northbound					PENDOLA PT Eastbound					Int. Total
	Left	Thru	Right	U-Turns	App. Total	Left	Thru	Right	U-Turns	App. Total	Left	Thru	Right	U-Turns	App. Total	Left	Thru	Right	U-Turns	App. Total	
Peak Hour Analysis From 12:00 PM to 05:45 PM - Peak 1 of 1																					
Peak Hour for Entire Intersection Begins at 05:00 PM																					
05:00 PM	92	402	2	0	496	13	0	44	5	62	0	122	4	0	126	3	3	0	0	6	690
05:15 PM	117	469	0	1	587	13	0	26	1	40	0	123	9	0	132	5	1	0	0	6	765
05:30 PM	89	395	0	0	484	13	0	34	4	51	0	132	9	0	141	2	2	0	0	4	680
05:45 PM	97	404	0	0	501	10	0	31	0	41	0	121	17	0	138	2	0	0	0	2	682
Total Volume	395	1670	2	1	2068	49	0	135	10	194	0	498	39	0	537	12	6	0	0	18	2817
% App. Total	19.1	80.8	0.1	0		25.3	0	69.6	5.2		0	92.7	7.3	0		66.7	33.3	0	0		
PHF	.844	.890	.250	.250	.881	.942	.000	.767	.500	.782	.000	.943	.574	.000	.952	.600	.500	.000	.000	.750	.921

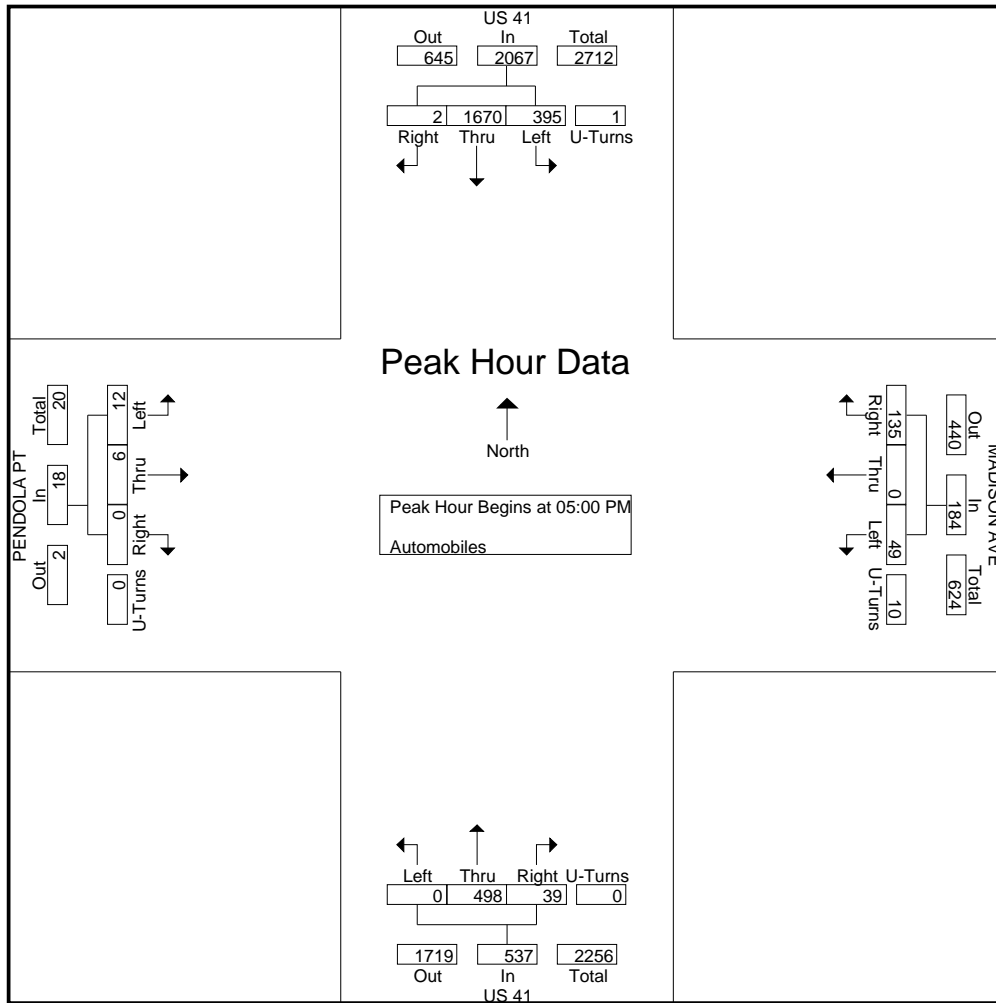



# Southern Traffic Services, Inc.

2911 Westfield Rd  
Gulf Breeze, FL 32563  
1-800-786-3374

*Traffic is our only business!*

US 41 @ Madison Ave  
Tampa, FL

File Name : 13015-9 US 41 @ Madison Ave  
Site Code : 13015-9  
Start Date : 1/8/2013  
Page No : 1

Groups Printed- Trucks - Buses

Start Time	US 41 Southbound				MADISON AVE Westbound				US 41 Northbound				PENDOLA PT Eastbound				Int. Total
	Left	Thru	Right	U-Turns	Left	Thru	Right	U-Turns	Left	Thru	Right	U-Turns	Left	Thru	Right	U-Turns	
07:00 AM	4	10	3	0	4	0	7	0	3	9	1	0	3	0	0	0	44
07:15 AM	8	23	5	0	1	3	5	0	1	3	6	0	2	0	1	0	58
07:30 AM	2	17	3	0	2	1	10	0	5	13	3	0	4	0	1	0	61
07:45 AM	4	16	7	0	1	1	5	0	2	17	4	0	2	2	5	0	66
<b>Total</b>	<b>18</b>	<b>66</b>	<b>18</b>	<b>0</b>	<b>8</b>	<b>5</b>	<b>27</b>	<b>0</b>	<b>11</b>	<b>42</b>	<b>14</b>	<b>0</b>	<b>11</b>	<b>2</b>	<b>7</b>	<b>0</b>	<b>229</b>
08:00 AM	8	29	4	0	1	2	11	0	2	11	0	0	2	4	2	0	76
08:15 AM	6	23	7	0	1	0	5	0	2	24	2	0	2	1	1	0	74
08:30 AM	7	19	1	0	1	0	8	0	2	18	1	0	3	2	2	0	64
08:45 AM	4	25	9	0	0	0	11	0	1	17	1	0	4	3	1	0	76
<b>Total</b>	<b>25</b>	<b>96</b>	<b>21</b>	<b>0</b>	<b>3</b>	<b>2</b>	<b>35</b>	<b>0</b>	<b>7</b>	<b>70</b>	<b>4</b>	<b>0</b>	<b>11</b>	<b>10</b>	<b>6</b>	<b>0</b>	<b>290</b>
<b>**BREAK**</b>																	
04:00 PM	9	17	3	0	1	1	5	0	0	18	1	0	3	1	0	0	59
04:15 PM	9	12	2	0	1	1	7	0	0	10	2	0	3	1	0	0	48
04:30 PM	2	8	1	0	0	0	6	0	0	17	1	0	1	2	2	0	40
04:45 PM	4	11	2	0	3	0	4	0	1	7	0	0	1	1	2	0	36
<b>Total</b>	<b>24</b>	<b>48</b>	<b>8</b>	<b>0</b>	<b>5</b>	<b>2</b>	<b>22</b>	<b>0</b>	<b>1</b>	<b>52</b>	<b>4</b>	<b>0</b>	<b>8</b>	<b>5</b>	<b>4</b>	<b>0</b>	<b>183</b>
05:00 PM	2	11	0	0	0	0	5	0	0	8	0	0	1	1	0	0	28
05:15 PM	6	10	0	0	2	0	1	0	0	9	2	0	0	0	0	0	30
05:30 PM	1	10	1	0	0	0	4	0	0	7	0	0	0	0	0	0	23
05:45 PM	4	5	2	0	3	0	4	0	0	9	1	0	0	1	0	0	29
<b>Total</b>	<b>13</b>	<b>36</b>	<b>3</b>	<b>0</b>	<b>5</b>	<b>0</b>	<b>14</b>	<b>0</b>	<b>0</b>	<b>33</b>	<b>3</b>	<b>0</b>	<b>1</b>	<b>2</b>	<b>0</b>	<b>0</b>	<b>110</b>
<b>Grand Total</b>	<b>80</b>	<b>246</b>	<b>50</b>	<b>0</b>	<b>21</b>	<b>9</b>	<b>98</b>	<b>0</b>	<b>19</b>	<b>197</b>	<b>25</b>	<b>0</b>	<b>31</b>	<b>19</b>	<b>17</b>	<b>0</b>	<b>812</b>
Apprch %	21.3	65.4	13.3	0	16.4	7	76.6	0	7.9	81.7	10.4	0	46.3	28.4	25.4	0	
Total %	9.9	30.3	6.2	0	2.6	1.1	12.1	0	2.3	24.3	3.1	0	3.8	2.3	2.1	0	
Trucks	79	240	50	0	21	9	97	0	19	196	23	0	31	19	17	0	801
% Trucks	98.8	97.6	100	0	100	100	99	0	100	99.5	92	0	100	100	100	0	98.6
Buses	1	6	0	0	0	0	1	0	0	1	2	0	0	0	0	0	11
% Buses	1.2	2.4	0	0	0	0	1	0	0	0.5	8	0	0	0	0	0	1.4





# Southern Traffic Services, Inc.

2911 Westfield Rd  
 Gulf Breeze, FL 32563  
 1-800-786-3374

*Traffic is our only business!*

US 41 @ Madison Ave  
 Tampa, FL

File Name : 13015-9 US 41 @ Madison Ave  
 Site Code : 13015-9  
 Start Date : 1/8/2013  
 Page No : 2

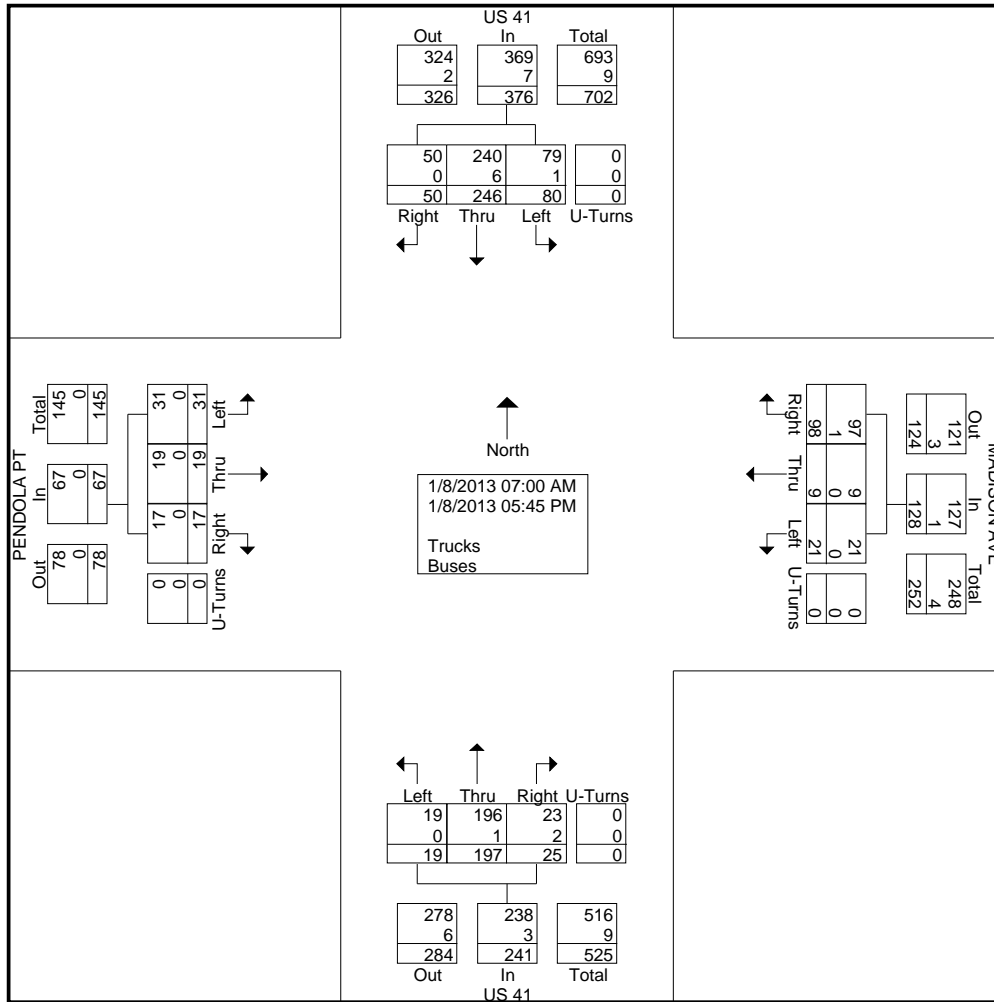



# Southern Traffic Services, Inc.

2911 Westfield Rd  
Gulf Breeze, FL 32563  
1-800-786-3374

*Traffic is our only business!*

US 41 @ Madison Ave  
Tampa, FL

File Name : 13015-9 US 41 @ Madison Ave  
Site Code : 13015-9  
Start Date : 1/8/2013  
Page No : 3

Start Time	US 41 Southbound				MADISON AVE Westbound				US 41 Northbound				PENDOLA PT Eastbound				Int. Total				
	Thru	Right	U-Turns	App. Total	Left	Thru	Right	U-Turns	App. Total	Left	Thru	Right	U-Turns	App. Total	App. Total						
Peak Hour Analysis From 07:00 AM to 11:45 AM - Peak 1 of 1																					
Peak Hour for Entire Intersection Begins at 08:00 AM																					
08:00 AM	8	29	4	0	41	1	2	11	0	14	2	11	0	0	13	2	4	2	0	8	76
08:15 AM	6	23	7	0	36	1	0	5	0	6	2	24	2	0	28	2	1	1	0	4	74
08:30 AM	7	19	1	0	27	1	0	8	0	9	2	18	1	0	21	3	2	2	0	7	64
08:45 AM	4	25	9	0	38	0	0	11	0	11	1	17	1	0	19	4	3	1	0	8	76
Total Volume	25	96	21	0	142	3	2	35	0	40	7	70	4	0	81	11	10	6	0	27	290
% App. Total	17.6	67.6	14.8	0		7.5	5	87.5	0		8.6	86.4	4.9	0		40.7	37	22.2	0		
PHF	.781	.828	.583	.000	.866	.750	.250	.795	.000	.714	.875	.729	.500	.000	.723	.688	.625	.750	.000	.844	.954

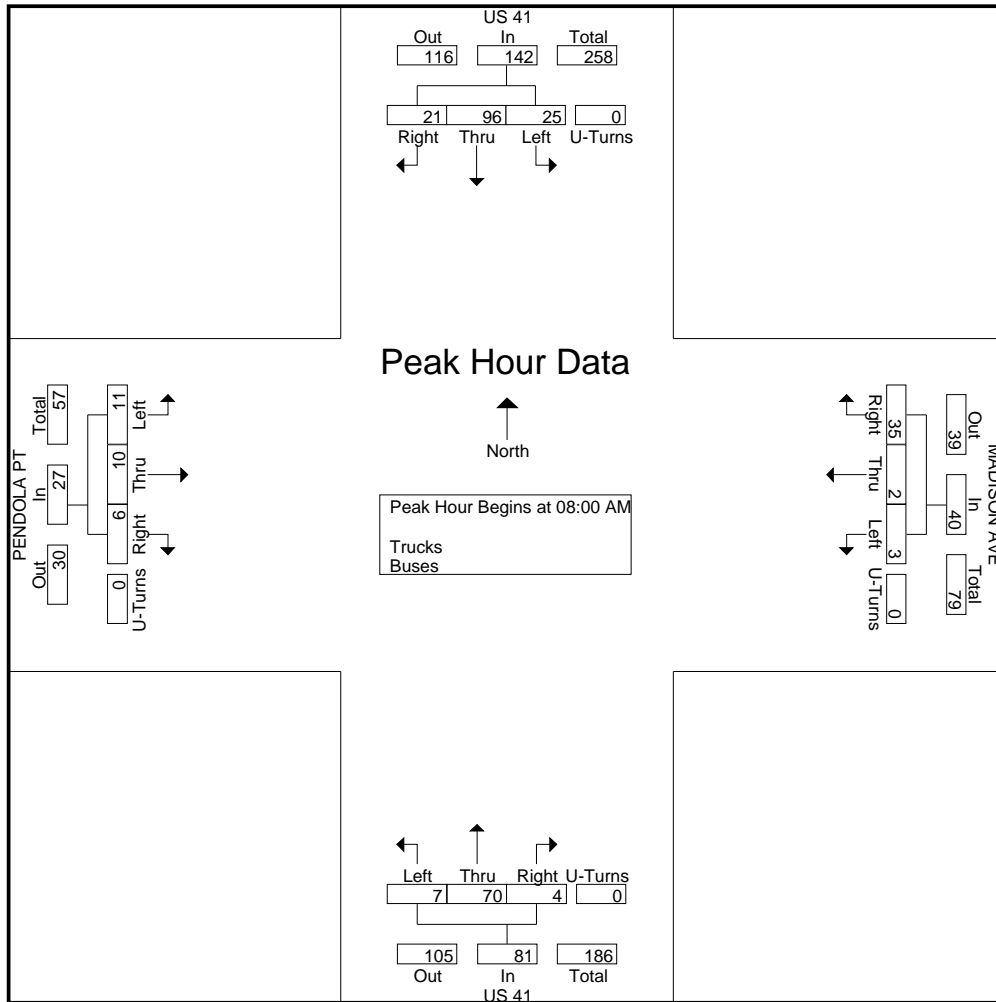



# Southern Traffic Services, Inc.

2911 Westfield Rd  
Gulf Breeze, FL 32563  
1-800-786-3374

*Traffic is our only business!*

US 41 @ Madison Ave  
Tampa, FL

File Name : 13015-9 US 41 @ Madison Ave  
Site Code : 13015-9  
Start Date : 1/8/2013  
Page No : 4

Start Time	US 41 Southbound					MADISON AVE Westbound					US 41 Northbound					PENDOLA PT Eastbound					Int. Total
	Left	Thru	Right	U-Turns	App. Total	Left	Thru	Right	U-Turns	App. Total	Left	Thru	Right	U-Turns	App. Total	Left	Thru	Right	U-Turns	App. Total	
Peak Hour Analysis From 12:00 PM to 05:45 PM - Peak 1 of 1																					
Peak Hour for Entire Intersection Begins at 04:00 PM																					
04:00 PM	9	17	3	0	29	1	1	5	0	7	0	18	1	0	19	3	1	0	0	4	59
04:15 PM	9	12	2	0	23	1	1	7	0	9	0	10	2	0	12	3	1	0	0	4	48
04:30 PM	2	8	1	0	11	0	0	6	0	6	0	17	1	0	18	1	2	2	0	5	40
04:45 PM	4	11	2	0	17	3	0	4	0	7	1	7	0	0	8	1	1	2	0	4	36
Total Volume	24	48	8	0	80	5	2	22	0	29	1	52	4	0	57	8	5	4	0	17	183
% App. Total	30	60	10	0		17.2	6.9	75.9	0		1.8	91.2	7	0		47.1	29.4	23.5	0		
PHF	.667	.706	.667	.000	.690	.417	.500	.786	.000	.806	.250	.722	.500	.000	.750	.667	.625	.500	.000	.850	.775

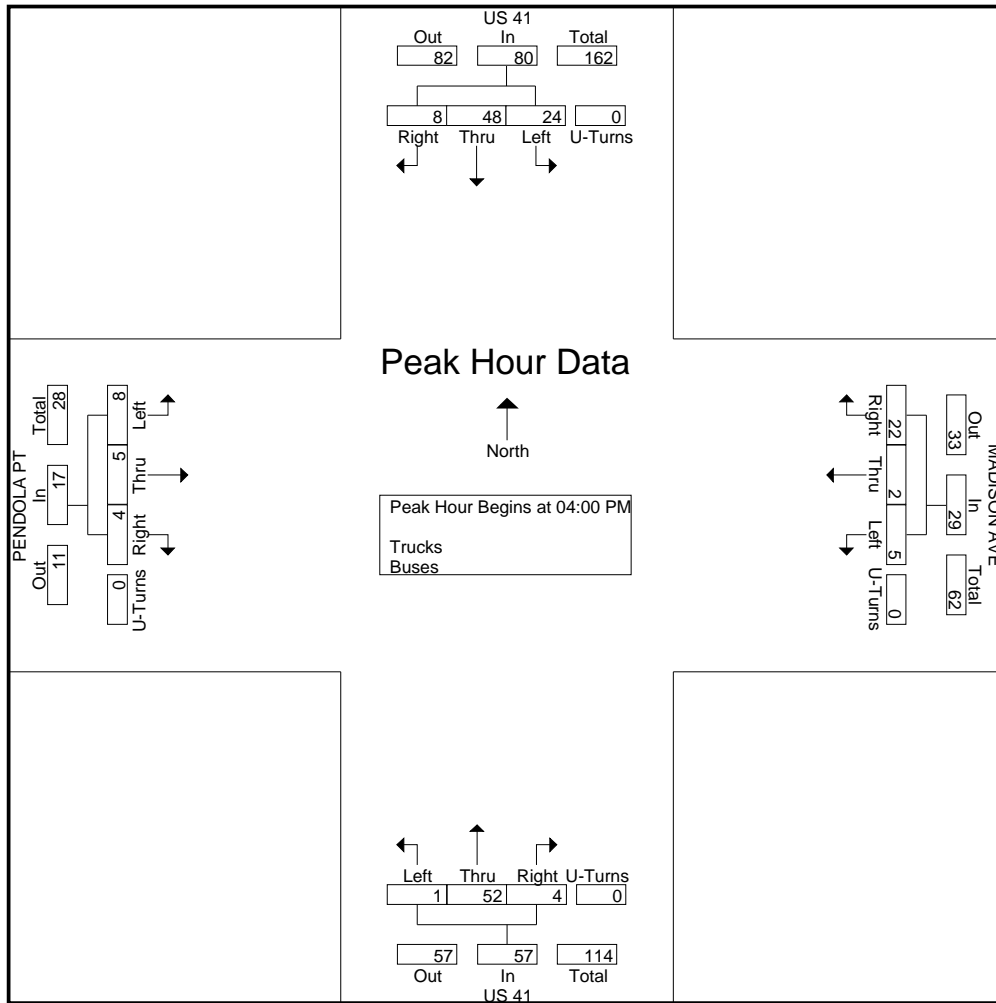



# Southern Traffic Services, Inc.

2911 Westfield Rd  
 Gulf Breeze, FL 32563  
 1-800-786-3374

*Traffic is our only business!*

US 41 @ Madison Ave  
 Tampa, FL

File Name : 13015-9 US 41 @ Madison Ave Peds  
 Site Code : 13015-9  
 Start Date : 1/8/2013  
 Page No : 1

Groups Printed- Peds

Start Time	US 41	MADISON AVE	US 41	PENDOLA PT	Int. Total
	Southbound	Westbound	Northbound	Eastbound	
	Peds	Peds	Peds	Peds	
07:00 AM	0	0	0	0	0
07:15 AM	0	0	0	0	0
07:30 AM	0	0	0	0	0
07:45 AM	1	0	0	0	1
<b>Total</b>	<b>1</b>	<b>0</b>	<b>0</b>	<b>0</b>	<b>1</b>
08:00 AM	0	0	0	0	0
08:15 AM	0	0	0	0	0
08:30 AM	0	0	0	0	0
08:45 AM	0	0	0	0	0
<b>Total</b>	<b>0</b>	<b>0</b>	<b>0</b>	<b>0</b>	<b>0</b>
09:00 AM	0	0	0	0	0
09:15 AM	0	0	0	0	0
09:30 AM	0	0	0	0	0
09:45 AM	0	0	0	0	0
<b>Total</b>	<b>0</b>	<b>0</b>	<b>0</b>	<b>0</b>	<b>0</b>
10:00 AM	0	0	0	0	0
10:15 AM	0	0	0	0	0
10:30 AM	0	0	0	0	0
10:45 AM	0	0	0	0	0
<b>Total</b>	<b>0</b>	<b>0</b>	<b>0</b>	<b>0</b>	<b>0</b>
11:00 AM	0	0	0	0	0
11:15 AM	0	0	0	0	0
11:30 AM	0	0	0	0	0
11:45 AM	0	0	0	0	0
<b>Total</b>	<b>0</b>	<b>0</b>	<b>0</b>	<b>0</b>	<b>0</b>
12:00 PM	0	0	0	0	0
12:15 PM	0	0	0	0	0
12:30 PM	0	0	0	0	0
12:45 PM	0	0	0	0	0
<b>Total</b>	<b>0</b>	<b>0</b>	<b>0</b>	<b>0</b>	<b>0</b>
01:00 PM	0	0	0	0	0
01:15 PM	0	0	0	0	0
01:30 PM	0	0	0	0	0
01:45 PM	0	0	0	0	0
<b>Total</b>	<b>0</b>	<b>0</b>	<b>0</b>	<b>0</b>	<b>0</b>
02:00 PM	0	0	0	0	0
02:15 PM	0	0	0	0	0
02:30 PM	0	0	0	0	0
02:45 PM	0	0	0	0	0
<b>Total</b>	<b>0</b>	<b>0</b>	<b>0</b>	<b>0</b>	<b>0</b>
03:00 PM	0	0	0	0	0
03:15 PM	0	0	0	0	0
03:30 PM	0	0	0	0	0
03:45 PM	0	0	0	0	0
<b>Total</b>	<b>0</b>	<b>0</b>	<b>0</b>	<b>0</b>	<b>0</b>



# Southern Traffic Services, Inc.

2911 Westfield Rd  
 Gulf Breeze, FL 32563  
 1-800-786-3374

*Traffic is our only business!*

US 41 @ Madison Ave  
 Tampa, FL

File Name : 13015-9 US 41 @ Madison Ave Peds  
 Site Code : 13015-9  
 Start Date : 1/8/2013  
 Page No : 2

Groups Printed- Peds

Start Time	US 41 Southbound	MADISON AVE Westbound	US 41 Northbound	PENDOLA PT Eastbound	Int. Total
	Peds	Peds	Peds	Peds	
04:00 PM	0	0	0	0	0
04:15 PM	0	0	0	0	0
04:30 PM	1	0	0	0	1
04:45 PM	0	0	0	0	0
Total	1	0	0	0	1
05:00 PM	2	1	0	0	3
05:15 PM	0	0	1	0	1
05:30 PM	0	0	2	0	2
05:45 PM	0	0	0	0	0
Total	2	1	3	0	6
Grand Total	4	1	3	0	8
Apprch %	100	100	100	0	
Total %	50	12.5	37.5	0	

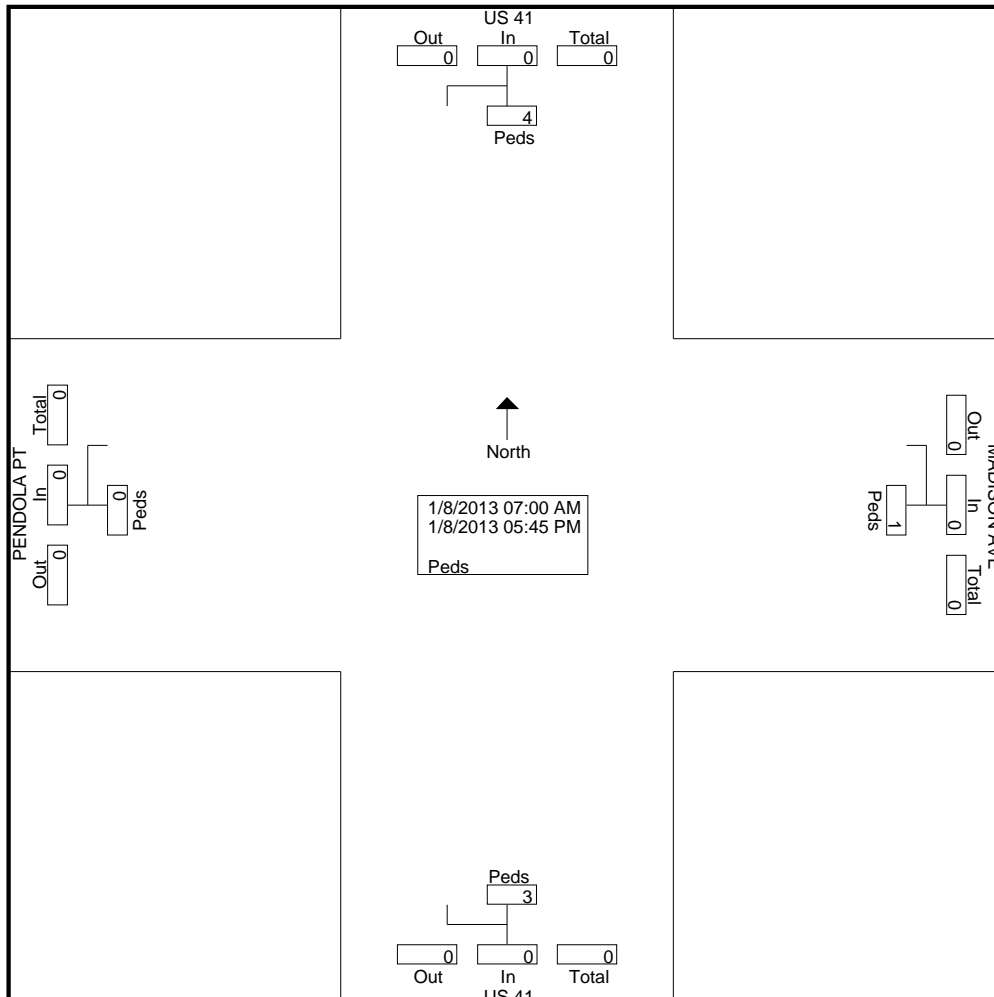

# Southern Traffic Services, Inc.

## Event Counts

**US 41 north of CR 676A (Madison Avenue)**

**Northbound**

**Datasets:**

**Site:** [091] I9008  
**Input A:** 5 - South bound A>B, North bound B>A. - Excluded from totals. (0)  
**Input B:** 0 - Unused or unknown. - Added to totals. (1)  
**Survey Duration:** 12:00 Monday, January 07, 2013 => 12:33 Friday, January 11, 2013  
**File:** G:\DATA\2013\Private\13015\diego\Data 1-7-13\UM091.eco (Plus)  
**Identifier:** AQ656QPJ MC56-L5 [MC55] (c)Microcom 19Oct04  
**Algorithm:** Event Count  
**Data type:** Axle sensors - Paired (Class, Speed, Count)

**Profile:**

**Filter time:** 0:00 Tuesday, January 08, 2013 => 0:00 Friday, January 11, 2013  
**Name:** Factory default profile  
**Scheme:** Count events divided by two.  
**Units:** Non metric (ft, mi, ft/s, mph, lb, ton)  
**In profile:** Events = 48695

**Tuesday, January 08, 2013=16110, 15 minute drops**

0000	0100	0200	0300	0400	0500	0600	0700	0800	0900	1000	1100	1200	1300	1400	1500	1600	1700	1800	1900	2000	2100	2200	2300	
69	62	54	143	257	705	1604	2382	1477	992	900	850	871	866	833	957	803	791	570	288	212	185	147	92	
17	17	14	29	38	116	302	650	433	243	243	198	215	232	175	241	220	225	172	88	46	48	43	28	20
14	17	12	28	47	161	385	581	379	278	207	248	231	131	231	238	184	177	165	74	48	39	45	21	21
20	14	17	44	82	191	287	602	382	236	221	197	230	270	201	293	217	205	131	76	68	48	35	25	21
18	14	11	42	90	237	630	549	283	235	229	207	195	233	226	185	182	184	102	50	50	50	24	18	12

AM Peak 0645 - 0745 (2463), AM PHF=0.95 PM Peak 1445 - 1545 (998), PM PHF=0.85

**Wednesday, January 09, 2013=16305, 15 minute drops**

0000	0100	0200	0300	0400	0500	0600	0700	0800	0900	1000	1100	1200	1300	1400	1500	1600	1700	1800	1900	2000	2100	2200	2300	
74	61	87	125	267	760	1738	2244	1536	962	909	691	930	799	862	925	891	794	614	318	201	238	171	108	
20	22	38	17	48	111	311	529	478	288	271	202	276	176	248	228	231	239	147	91	49	66	54	39	24
21	14	11	34	48	151	416	554	407	240	202	176	191	226	224	187	230	178	169	99	49	60	47	28	13
21	13	25	36	79	244	508	601	377	217	211	183	253	170	198	271	237	184	163	78	48	63	43	20	11
12	12	13	38	92	254	503	560	274	217	225	130	210	227	192	239	193	193	135	50	55	49	27	21	12

AM Peak 0700 - 0800 (2244), AM PHF=0.93 PM Peak 1530 - 1630 (971), PM PHF=0.90

**Thursday, January 10, 2013=16280, 15 minute drops**

0000	0100	0200	0300	0400	0500	0600	0700	0800	0900	1000	1100	1200	1300	1400	1500	1600	1700	1800	1900	2000	2100	2200	2300	
60	60	67	93	258	766	1625	2243	1517	972	816	882	827	881	890	1027	873	786	602	316	238	197	180	104	
24	25	15	13	26	122	298	516	418	239	166	230	217	235	226	273	251	195	167	107	60	56	49	13	15
13	4	20	25	68	167	378	571	454	250	232	215	185	192	213	240	224	228	184	89	57	55	54	43	18
11	19	17	30	82	236	407	583	352	238	181	223	216	247	192	301	215	191	150	67	75	48	47	26	9
12	12	15	25	82	241	542	573	293	245	237	214	209	207	259	213	183	172	101	53	46	38	30	22	16

AM Peak 0700 - 0800 (2243), AM PHF=0.96 PM Peak 1445 - 1545 (1073), PM PHF=0.89

# Southern Traffic Services, Inc.

## Event Counts

**US 41 north of CR 676A (Madison Avenue)**

**Southbound**

**Datasets:**

**Site:** [091] I9008  
**Input A:** 5 - South bound A>B, North bound B>A. - Added to totals. (1)  
**Input B:** 0 - Unused or unknown. - Excluded from totals. (0)  
**Survey Duration:** 12:00 Monday, January 07, 2013 => 12:33 Friday, January 11, 2013  
**File:** G:\DATA\2013\Private\13015\diego\Data 1-7-13\UM091.eco (Plus)  
**Identifier:** AQ656QPJ MC56-L5 [MC55] (c)Microcom 19Oct04  
**Algorithm:** Event Count  
**Data type:** Axle sensors - Paired (Class, Speed, Count)

**Profile:**

**Filter time:** 0:00 Tuesday, January 08, 2013 => 0:00 Friday, January 11, 2013  
**Name:** Factory default profile  
**Scheme:** Count events divided by two.  
**Units:** Non metric (ft, mi, ft/s, mph, lb, ton)  
**In profile:** Events = 50877

**Tuesday, January 08, 2013=16803, 15 minute drops**

0000	0100	0200	0300	0400	0500	0600	0700	0800	0900	1000	1100	1200	1300	1400	1500	1600	1700	1800	1900	2000	2100	2200	2300	
205	112	97	118	162	357	612	703	760	680	661	813	773	868	756	1446	1813	2168	1442	778	546	387	303	243	
92	26	30	12	44	46	144	164	209	175	145	187	206	193	199	337	398	536	465	227	155	97	107	64	30
52	38	26	36	26	82	145	184	223	180	193	198	183	242	235	348	426	559	388	172	166	92	80	73	28
34	20	20	34	37	108	158	154	169	165	174	190	203	231	219	348	473	550	330	201	118	102	72	54	28
27	28	21	36	55	121	165	201	159	160	149	238	181	202	103	413	516	523	259	178	107	96	44	52	21

AM Peak 1115 - 1215 (832), AM PHF=0.87 PM Peak 1700 - 1800 (2168), PM PHF=0.97

**Wednesday, January 09, 2013=17055, 15 minute drops**

0000	0100	0200	0300	0400	0500	0600	0700	0800	0900	1000	1100	1200	1300	1400	1500	1600	1700	1800	1900	2000	2100	2200	2300	
107	136	93	100	166	430	558	832	730	695	694	860	743	808	969	1371	1790	2230	1386	678	551	466	369	293	
30	41	33	22	42	53	141	227	172	165	179	208	146	190	236	297	417	602	416	151	155	126	102	79	49
28	31	30	30	33	95	93	216	208	184	157	215	209	228	232	321	436	527	421	185	147	103	113	66	47
28	37	18	30	51	136	216	192	176	172	180	215	201	179	262	339	460	553	304	193	125	137	63	77	32
21	27	12	18	40	146	108	197	174	174	178	222	187	211	239	414	477	548	245	149	124	100	91	71	38

AM Peak 1100 - 1200 (860), AM PHF=0.97 PM Peak 1700 - 1800 (2230), PM PHF=0.93

**Thursday, January 10, 2013=17019, 15 minute drops**

0000	0100	0200	0300	0400	0500	0600	0700	0800	0900	1000	1100	1200	1300	1400	1500	1600	1700	1800	1900	2000	2100	2200	2300	
166	107	110	111	182	324	644	764	559	763	687	759	850	773	1006	1376	1815	2136	1451	769	595	418	388	266	
49	40	34	24	35	47	158	177	150	278	135	178	186	185	238	287	427	530	386	257	144	97	97	76	49
47	26	27	20	42	71	161	200	175	139	175	129	253	138	262	333	443	574	431	213	180	139	110	62	55
32	30	22	29	43	107	110	198	165	166	191	241	220	245	240	365	446	562	360	162	125	84	90	74	49
38	11	27	38	62	99	215	189	69	180	186	211	191	205	266	391	499	470	274	137	146	98	91	54	23

AM Peak 1130 - 1230 (891), AM PHF=0.88 PM Peak 1645 - 1745 (2165), PM PHF=0.94

# Southern Traffic Services, Inc.

## Event Counts

**US 41 south of CR 676A (Madison Avenue)**

**Northbound**

**Datasets:**

**Site:** [092] I7025  
**Input A:** 6 - West bound A>B, East bound B>A. - Excluded from totals. (0)  
**Input B:** 0 - Unused or unknown. - Added to totals. (1)  
**Survey Duration:** 13:18 Monday, January 07, 2013 => 12:29 Friday, January 11, 2013  
**File:** G:\DATA\2013\Private\13015\diego\Data 1-7-13\UM092.eco (Plus)  
**Identifier:** U754E19Y MC56-L5 [MC55] (c)Microcom 19Oct04  
**Algorithm:** Event Count  
**Data type:** Axle sensors - Paired (Class, Speed, Count)

**Profile:**

**Filter time:** 0:00 Tuesday, January 08, 2013 => 0:00 Friday, January 11, 2013  
**Name:** Factory default profile  
**Scheme:** Count events divided by two.  
**Units:** Non metric (ft, mi, ft/s, mph, lb, ton)  
**In profile:** Events = 39324

**Tuesday, January 08, 2013=13012, 15 minute drops**

0000	0100	0200	0300	0400	0500	0600	0700	0800	0900	1000	1100	1200	1300	1400	1500	1600	1700	1800	1900	2000	2100	2200	2300	
52	42	35	92	164	576	1391	2037	1292	802	686	653	669	665	654	749	606	630	441	244	179	164	115	74	
14	12	7	16	20	98	256	526	401	182	175	162	162	177	128	188	159	155	134	79	43	37	34	21	19
13	12	11	20	41	129	330	500	323	227	170	182	163	86	194	143	141	145	127	58	41	47	34	21	14
9	11	11	29	44	157	201	527	342	204	167	145	179	224	143	256	169	169	100	64	52	44	24	21	18
16	7	6	27	59	192	604	484	226	189	174	164	165	178	189	162	137	161	80	43	43	36	23	11	10

AM Peak 0645 - 0745 (2157), AM PHF=0.89 PM Peak 1445 - 1545 (776), PM PHF=0.76

**Wednesday, January 09, 2013=13350, 15 minute drops**

0000	0100	0200	0300	0400	0500	0600	0700	0800	0900	1000	1100	1200	1300	1400	1500	1600	1700	1800	1900	2000	2100	2200	2300	
61	44	50	95	204	636	1441	1913	1296	799	751	560	784	623	697	746	664	622	470	271	182	213	142	86	
19	7	20	13	33	96	274	446	413	226	205	167	242	159	204	181	185	195	125	77	43	57	37	28	15
14	16	11	25	42	128	363	476	339	199	182	150	132	170	192	155	164	138	125	85	52	56	43	24	17
18	9	11	26	60	185	431	496	294	186	159	158	239	120	146	224	163	136	115	70	43	56	34	17	9
10	12	8	31	69	227	373	495	250	188	205	85	171	174	155	186	152	153	105	39	44	44	28	17	9

AM Peak 0700 - 0800 (1913), AM PHF=0.96 PM Peak 1200 - 1300 (784), PM PHF=0.81

**Thursday, January 10, 2013=12962, 15 minute drops**

0000	0100	0200	0300	0400	0500	0600	0700	0800	0900	1000	1100	1200	1300	1400	1500	1600	1700	1800	1900	2000	2100	2200	2300	
50	40	43	77	184	607	1402	1941	1285	780	658	686	651	637	641	736	669	591	434	259	196	174	142	79	
15	8	8	13	16	104	249	449	383	197	146	175	174	165	160	162	177	151	122	90	43	45	31	0	13
17	7	10	24	51	115	346	472	382	220	200	171	149	151	164	153	167	161	120	68	47	58	44	40	21
9	14	16	25	56	180	313	525	285	183	112	170	168	152	137	252	176	145	105	60	66	37	43	24	7
9	11	9	15	61	208	494	495	235	180	200	170	160	169	180	169	149	134	87	41	40	34	24	15	13

AM Peak 0700 - 0800 (1941), AM PHF=0.92 PM Peak 1530 - 1630 (765), PM PHF=0.76



# Southern Traffic Services, Inc.

## Event Counts

**US 41 south of CR 676A (Madison Avenue)**

**Southbound**

**Datasets:**

**Site:** [092] I7025  
**Input A:** 6 - West bound A>B, East bound B>A. - Added to totals. (1)  
**Input B:** 0 - Unused or unknown. - Excluded from totals. (0)  
**Survey Duration:** 13:18 Monday, January 07, 2013 => 12:29 Friday, January 11, 2013  
**File:** G:\DATA\2013\Private\13015\diego\Data 1-7-13\UM092.eco (Plus)  
**Identifier:** U754E19Y MC56-L5 [MC55] (c)Microcom 19Oct04  
**Algorithm:** Event Count  
**Data type:** Axle sensors - Paired (Class, Speed, Count)

**Profile:**

**Filter time:** 0:00 Tuesday, January 08, 2013 => 0:00 Friday, January 11, 2013  
**Name:** Factory default profile  
**Scheme:** Count events divided by two.  
**Units:** Non metric (ft, mi, ft/s, mph, lb, ton)  
**In profile:** Events = 42050

**Tuesday, January 08, 2013=13980, 15 minute drops**

0000	0100	0200	0300	0400	0500	0600	0700	0800	0900	1000	1100	1200	1300	1400	1500	1600	1700	1800	1900	2000	2100	2200	2300	
173	91	63	76	119	223	465	544	602	575	565	683	636	725	670	1174	1538	1882	1247	656	484	333	260	196	
73	21	21	10	35	35	106	138	172	156	134	138	154	190	192	253	358	467	389	199	139	86	96	49	33
54	36	18	18	26	54	121	122	160	150	138	177	165	177	185	288	344	485	345	147	148	84	61	55	25
28	17	16	26	22	57	115	143	154	138	155	165	161	168	174	259	419	461	296	160	100	84	65	51	23
18	17	8	22	36	77	123	141	116	131	138	203	156	190	119	374	417	469	217	150	97	79	38	41	11

AM Peak 1115 - 1215 (699), AM PHF=0.86 PM Peak 1700 - 1800 (1882), PM PHF=0.97

**Wednesday, January 09, 2013=14135, 15 minute drops**

0000	0100	0200	0300	0400	0500	0600	0700	0800	0900	1000	1100	1200	1300	1400	1500	1600	1700	1800	1900	2000	2100	2200	2300	
92	111	73	55	119	288	471	615	629	595	638	701	658	687	770	1102	1469	1848	1197	586	485	397	303	246	
33	34	24	14	31	34	115	162	158	152	177	183	117	188	205	245	354	493	361	145	135	105	78	64	43
25	29	29	13	23	50	95	146	165	168	158	181	188	196	159	250	386	482	365	151	120	78	95	55	32
23	30	11	21	39	98	160	168	178	126	142	183	173	149	212	265	355	437	261	182	129	129	60	61	30
11	18	9	7	26	106	101	139	128	149	161	154	180	154	194	342	374	436	210	108	101	85	70	66	29

AM Peak 1045 - 1145 (708), AM PHF=0.97 PM Peak 1700 - 1800 (1848), PM PHF=0.94

**Thursday, January 10, 2013=13935, 15 minute drops**

0000	0100	0200	0300	0400	0500	0600	0700	0800	0900	1000	1100	1200	1300	1400	1500	1600	1700	1800	1900	2000	2100	2200	2300	
134	89	72	63	122	228	529	624	466	634	595	623	659	682	803	1101	1502	1736	1213	675	487	359	324	215	
43	29	24	16	35	43	135	153	124	230	132	130	161	188	181	222	349	410	367	224	120	92	71	61	40
32	22	14	15	26	41	135	133	134	121	145	140	183	142	215	260	342	453	308	194	144	111	88	52	40
30	27	20	18	27	65	115	177	148	122	142	198	192	178	190	258	396	492	322	132	107	69	87	58	42
29	11	14	14	34	79	144	161	60	161	176	155	123	174	217	361	415	381	216	125	116	87	78	44	27

AM Peak 1130 - 1230 (697), AM PHF=0.88 PM Peak 1645 - 1745 (1770), PM PHF=0.90

# Southern Traffic Services, Inc.

## Event Counts

**CR 676A (Madison Avenue) east of US 41**

**Eastbound**

**Datasets:**

**Site:** [093] I9038  
**Input A:** 8 - East bound A>B, West bound B>A. - Added to totals. (1)  
**Input B:** 0 - Unused or unknown. - Excluded from totals. (0)  
**Survey Duration:** 8:01 Monday, January 07, 2013 => 12:31 Friday, January 11, 2013  
**File:** G:\DATA\2013\Private\13015\diego\Data 1-7-13\UM093.eco (Plus)  
**Identifier:** AQ09MEMX MC56-L5 [MC55] (c)Microcom 19Oct04  
**Algorithm:** Event Count  
**Data type:** Axle sensors - Paired (Class, Speed, Count)

**Profile:**

**Filter time:** 0:00 Tuesday, January 08, 2013 => 0:00 Friday, January 11, 2013  
**Name:** Factory default profile  
**Scheme:** Count events divided by two.  
**Units:** Non metric (ft, mi, ft/s, mph, lb, ton)  
**In profile:** Events = 14893

**Tuesday, January 08, 2013=4795, 15 minute drops**

0000	0100	0200	0300	0400	0500	0600	0700	0800	0900	1000	1100	1200	1300	1400	1500	1600	1700	1800	1900	2000	2100	2200	2300	
58	26	30	51	60	125	187	255	265	208	204	279	267	269	257	472	417	466	335	191	122	101	85	65	
24	7	8	8	7	7	38	48	89	35	47	76	86	63	68	112	99	117	120	51	34	18	25	12	3
9	3	10	15	9	25	35	91	80	60	58	71	67	72	77	101	92	142	76	41	35	29	26	24	9
17	8	8	8	17	49	49	40	46	58	53	57	79	73	59	153	105	104	65	56	22	23	13	14	6
8	8	4	20	27	44	65	76	50	55	46	75	35	61	53	106	121	103	74	43	31	31	21	15	12

AM Peak 1145 - 1245 (307), AM PHF=0.89 PM Peak 1630 - 1730 (485), PM PHF=0.85

**Wednesday, January 09, 2013=5051, 15 minute drops**

0000	0100	0200	0300	0400	0500	0600	0700	0800	0900	1000	1100	1200	1300	1400	1500	1600	1700	1800	1900	2000	2100	2200	2300	
30	41	29	52	73	149	164	311	315	210	257	319	271	276	319	429	429	485	307	161	122	119	95	88	
3	6	8	13	11	32	27	73	102	45	71	64	62	64	83	85	87	138	97	45	31	29	32	23	9
9	8	9	11	13	30	33	78	83	49	61	73	79	71	57	96	112	117	67	28	28	38	30	15	19
6	12	10	15	32	38	54	68	53	51	47	92	72	80	96	133	123	125	77	42	28	35	12	33	11
12	15	2	13	17	49	50	92	77	65	78	90	58	61	83	115	107	105	66	46	35	17	21	17	13

AM Peak 0730 - 0830 (345), AM PHF=0.85 PM Peak 1645 - 1745 (487), PM PHF=0.88

**Thursday, January 10, 2013=5047, 15 minute drops**

0000	0100	0200	0300	0400	0500	0600	0700	0800	0900	1000	1100	1200	1300	1400	1500	1600	1700	1800	1900	2000	2100	2200	2300	
52	30	32	55	83	121	161	315	253	267	224	285	345	258	359	406	424	505	307	167	139	111	78	70	
9	10	17	15	17	21	46	63	81	82	46	81	109	61	88	79	87	130	92	68	42	28	30	21	8
19	10	3	14	21	20	33	71	75	47	56	62	72	52	72	93	115	139	86	48	37	34	22	13	15
11	8	6	10	24	42	36	95	53	74	63	77	97	60	91	137	104	123	76	30	27	27	14	21	18
13	2	6	16	21	38	46	86	44	64	59	65	67	85	108	97	118	113	53	21	33	22	12	15	15

AM Peak 1145 - 1245 (343), AM PHF=0.79 PM Peak 1645 - 1745 (510), PM PHF=0.92

# Southern Traffic Services, Inc.

## Event Counts

**CR 676A (Madison Avenue) east of US 41**

**Westbound**

**Datasets:**

**Site:** [093] I9038  
**Input A:** 8 - East bound A>B, West bound B>A. - Excluded from totals. (0)  
**Input B:** 0 - Unused or unknown. - Added to totals. (1)  
**Survey Duration:** 8:01 Monday, January 07, 2013 => 12:31 Friday, January 11, 2013  
**File:** G:\DATA\2013\Private\13015\diego\Data 1-7-13\UM093.eco (Plus)  
**Identifier:** AQ09MEMX MC56-L5 [MC55] (c)Microcom 19Oct04  
**Algorithm:** Event Count  
**Data type:** Axle sensors - Paired (Class, Speed, Count)

**Profile:**

**Filter time:** 0:00 Tuesday, January 08, 2013 => 0:00 Friday, January 11, 2013  
**Name:** Factory default profile  
**Scheme:** Count events divided by two.  
**Units:** Non metric (ft, mi, ft/s, mph, lb, ton)  
**In profile:** Events = 28465 / 35088 (81.12%)

**Tuesday, January 08, 2013=4396, 15 minute drops**

0000	0100	0200	0300	0400	0500	0600	0700	0800	0900	1000	1100	1200	1300	1400	1500	1600	1700	1800	1900	2000	2100	2200	2300	
20	23	31	40	106	159	402	465	321	265	233	267	269	269	244	274	258	246	170	105	69	60	50	50	
4	9	8	4	15	17	73	116	97	70	63	74	76	59	55	79	68	79	54	28	14	14	15	12	2
3	2	4	4	19	44	90	114	89	77	56	70	72	67	63	59	71	56	56	22	18	4	14	9	7
9	8	12	17	27	45	122	129	63	37	53	58	51	76	74	72	69	61	39	31	19	20	14	23	8
4	4	7	15	45	53	117	106	72	81	61	65	70	67	52	64	50	50	21	24	18	22	7	6	4

AM Peak 0645 - 0745 (476), AM PHF=0.92 PM Peak 1530 - 1630 (275), PM PHF=0.95

**Wednesday, January 09, 2013=4542, 15 minute drops**

0000	0100	0200	0300	0400	0500	0600	0700	0800	0900	1000	1100	1200	1300	1400	1500	1600	1700	1800	1900	2000	2100	2200	2300	
21	33	44	29	78	186	382	481	403	231	267	262	294	300	227	257	280	257	188	81	67	69	51	54	
2	14	21	8	16	36	72	95	137	52	77	59	106	71	52	58	72	83	39	22	16	19	16	19	5
7	2	7	6	11	30	86	117	107	68	68	56	58	87	58	58	72	59	52	22	26	17	13	10	2
8	11	10	8	36	58	99	142	92	48	63	78	76	75	72	67	75	57	53	18	12	13	15	13	7
4	6	6	7	15	62	125	127	67	63	59	69	54	67	45	74	61	58	44	19	13	20	7	12	5

AM Peak 0715 - 0815 (523), AM PHF=0.92 PM Peak 1300 - 1400 (300), PM PHF=0.86

**Thursday, January 10, 2013=4549, 15 minute drops**

0000	0100	0200	0300	0400	0500	0600	0700	0800	0900	1000	1100	1200	1300	1400	1500	1600	1700	1800	1900	2000	2100	2200	2300	
19	29	20	18	90	204	409	466	350	286	253	283	285	299	269	267	246	249	194	94	74	53	58	34	
5	20	5	0	23	29	82	97	121	81	54	84	102	85	71	87	83	70	70	30	23	14	19	11	5
2	1	3	9	20	56	97	138	84	65	62	76	63	57	70	67	59	75	52	26	20	15	22	8	7
7	8	5	4	22	68	123	122	84	74	67	51	63	84	71	60	58	58	47	22	14	15	5	8	9
5	0	7	5	25	51	107	109	61	66	70	72	57	73	57	53	46	46	25	16	17	9	12	7	8

AM Peak 0715 - 0815 (490), AM PHF=0.89 PM Peak 1300 - 1400 (299), PM PHF=0.88

# Southern Traffic Services, Inc.

## Event Counts

**Pendola Point Road west of US 41 Eastbound**

**Datasets:**

**Site:** [094] I5155  
**Input A:** 6 - West bound A>B, East bound B>A. - Added to totals. (1)  
**Input B:** 0 - Unused or unknown. - Subtracted from totals. (-1)  
**Survey Duration:** 8:00 Monday, January 07, 2013 => 12:32 Friday, January 11, 2013  
**File:** G:\DATA\2013\Private\13015\diego\Data 1-7-13\UM094.eco (Plus)  
**Identifier:** Q7465NWN MC56-L5 [MC55] (c)Microcom 19Oct04  
**Algorithm:** Event Count  
**Data type:** Axle sensors - Paired (Class, Speed, Count)

**Profile:**

**Filter time:** 0:00 Tuesday, January 08, 2013 => 0:00 Friday, January 11, 2013  
**Name:** Factory default profile  
**Scheme:** Count events divided by two.  
**Units:** Non metric (ft, mi, ft/s, mph, lb, ton)  
**In profile:** Events = 2921

**Tuesday, January 08, 2013=979, 15 minute drops**

0000	0100	0200	0300	0400	0500	0600	0700	0800	0900	1000	1100	1200	1300	1400	1500	1600	1700	1800	1900	2000	2100	2200	2300	
11	10	9	11	7	7	50	49	59	81	96	88	84	73	74	91	60	27	25	18	8	12	15	14	
1	0	2	2	0	3	1	10	15	21	23	27	25	16	22	19	10	14	5	4	7	8	3	2	0
3	2	3	3	3	2	16	7	9	17	25	24	19	22	18	25	12	6	4	4	0	2	0	5	4
7	6	2	0	2	2	17	14	18	29	33	18	20	9	13	33	21	3	10	7	1	2	7	3	1
0	2	2	6	2	0	16	18	17	14	15	19	20	26	21	14	17	4	6	3	0	0	5	4	1

AM Peak 1015 - 1115 (100), AM PHF=0.76 PM Peak 1445 - 1545 (98), PM PHF=0.74

**Wednesday, January 09, 2013=933, 15 minute drops**

0000	0100	0200	0300	0400	0500	0600	0700	0800	0900	1000	1100	1200	1300	1400	1500	1600	1700	1800	1900	2000	2100	2200	2300	
6	14	11	9	12	5	36	46	65	51	99	100	103	53	62	95	44	42	25	8	12	11	4	20	
0	3	4	2	4	4	5	4	15	12	24	24	32	15	13	22	7	14	7	3	3	4	2	8	0
4	4	1	3	2	0	15	15	18	13	31	26	28	17	13	11	16	7	7	0	0	3	1	1	3
1	2	6	2	4	0	14	14	18	19	26	25	14	18	28	50	9	10	7	2	3	4	1	7	8
1	5	0	2	2	1	2	13	14	7	18	25	29	3	8	12	12	11	4	3	6	0	0	4	0

AM Peak 1130 - 1230 (110), AM PHF=0.86 PM Peak 1200 - 1300 (103), PM PHF=0.80

**Thursday, January 10, 2013=1009, 15 minute drops**

0000	0100	0200	0300	0400	0500	0600	0700	0800	0900	1000	1100	1200	1300	1400	1500	1600	1700	1800	1900	2000	2100	2200	2300	
11	13	9	13	15	14	39	64	54	64	81	87	91	109	81	79	43	52	27	10	19	12	4	18	
0	2	2	5	6	2	6	15	5	10	20	30	31	22	20	23	8	20	10	7	7	3	0	3	0
3	5	3	2	3	1	5	18	21	8	27	24	16	27	25	19	11	16	4	3	4	0	0	4	2
8	2	1	3	6	5	19	10	18	21	10	16	21	32	25	19	7	8	10	0	2	3	2	7	12
0	4	3	3	0	6	9	21	10	25	24	17	23	28	11	18	17	8	3	0	6	6	2	4	2

AM Peak 1045 - 1145 (94), AM PHF=0.78 PM Peak 1300 - 1400 (109), PM PHF=0.85

# Southern Traffic Services, Inc.

## Event Counts

**Pendola Point Road west of US 41**

**Westbound**

**Datasets:**

**Site:** [094] I5155  
**Input A:** 6 - West bound A>B, East bound B>A. - Excluded from totals. (0)  
**Input B:** 0 - Unused or unknown. - Added to totals. (1)  
**Survey Duration:** 8:00 Monday, January 07, 2013 => 12:32 Friday, January 11, 2013  
**File:** G:\DATA\2013\Private\13015\diego\Data 1-7-13\UM094.eco (Plus)  
**Identifier:** Q7465NWN MC56-L5 [MC55] (c)Microcom 19Oct04  
**Algorithm:** Event Count  
**Data type:** Axle sensors - Paired (Class, Speed, Count)

**Profile:**

**Filter time:** 0:00 Tuesday, January 08, 2013 => 0:00 Friday, January 11, 2013  
**Name:** Factory default profile  
**Scheme:** Count events divided by two.  
**Units:** Non metric (ft, mi, ft/s, mph, lb, ton)  
**In profile:** Events = 2957

**Tuesday, January 08, 2013=1003, 15 minute drops**

0000	0100	0200	0300	0400	0500	0600	0700	0800	0900	1000	1100	1200	1300	1400	1500	1600	1700	1800	1900	2000	2100	2200	2300	
15	8	11	9	14	55	145	89	83	93	85	55	73	95	32	37	26	8	14	17	8	6	11	14	
9	0	4	0	7	11	37	12	20	14	19	13	21	18	6	18	6	2	4	4	1	2	3	4	1
2	4	2	4	1	15	31	29	24	27	31	12	19	29	9	6	11	0	6	5	2	2	2	5	0
0	2	0	2	3	13	41	21	12	23	18	19	22	33	10	11	3	2	0	6	0	0	6	3	0
4	2	5	3	3	16	36	27	27	29	17	11	11	15	7	2	6	4	4	2	5	2	0	2	1

AM Peak 0600 - 0700 (145), AM PHF=0.88 PM Peak 1300 - 1400 (95), PM PHF=0.72

**Wednesday, January 09, 2013=949, 15 minute drops**

0000	0100	0200	0300	0400	0500	0600	0700	0800	0900	1000	1100	1200	1300	1400	1500	1600	1700	1800	1900	2000	2100	2200	2300	
2	15	10	14	14	48	111	88	62	74	82	97	84	66	38	41	25	20	11	5	13	10	6	13	
1	7	3	0	3	5	17	32	11	19	20	16	30	34	11	17	6	2	4	1	4	5	0	2	0
0	0	3	5	2	11	16	18	17	15	23	26	38	11	17	13	6	3	2	2	3	2	1	6	8
0	4	4	4	5	12	52	6	19	30	11	18	9	7	3	1	10	7	4	2	3	1	0	1	0
1	4	0	5	4	20	26	32	15	10	28	37	7	14	7	10	3	8	1	0	3	2	5	4	2

AM Peak 0630 - 0730 (128), AM PHF=0.62 PM Peak 1215 - 1315 (88), PM PHF=0.58

**Thursday, January 10, 2013=1005, 15 minute drops**

0000	0100	0200	0300	0400	0500	0600	0700	0800	0900	1000	1100	1200	1300	1400	1500	1600	1700	1800	1900	2000	2100	2200	2300	
10	14	13	14	17	40	130	80	65	74	92	68	94	91	51	38	31	18	11	6	16	9	9	14	
0	5	0	5	2	3	16	24	20	23	19	26	24	30	8	8	8	8	2	1	5	0	1	4	2
8	4	5	0	6	16	23	24	18	15	26	10	19	13	18	14	6	6	1	0	3	7	2	6	10
0	3	3	5	4	14	32	8	14	26	31	14	25	19	14	9	5	4	4	1	3	2	3	1	2
2	2	5	4	5	7	59	24	13	10	16	18	26	29	11	7	12	0	4	4	5	0	3	3	2

AM Peak 0630 - 0730 (139), AM PHF=0.59 PM Peak 1215 - 1315 (100), PM PHF=0.83





# Southern Traffic Services, Inc.

2911 Westfield Rd  
 Gulf Breeze, FL 32563  
 1-800-786-3374

*Traffic is our only business!*

US 41 @ Port Sutton Rd  
 Tampa, FL

File Name : 13015-10 US 41 @ Port Sutton Rd  
 Site Code : 13015-10  
 Start Date : 1/8/2013  
 Page No : 2

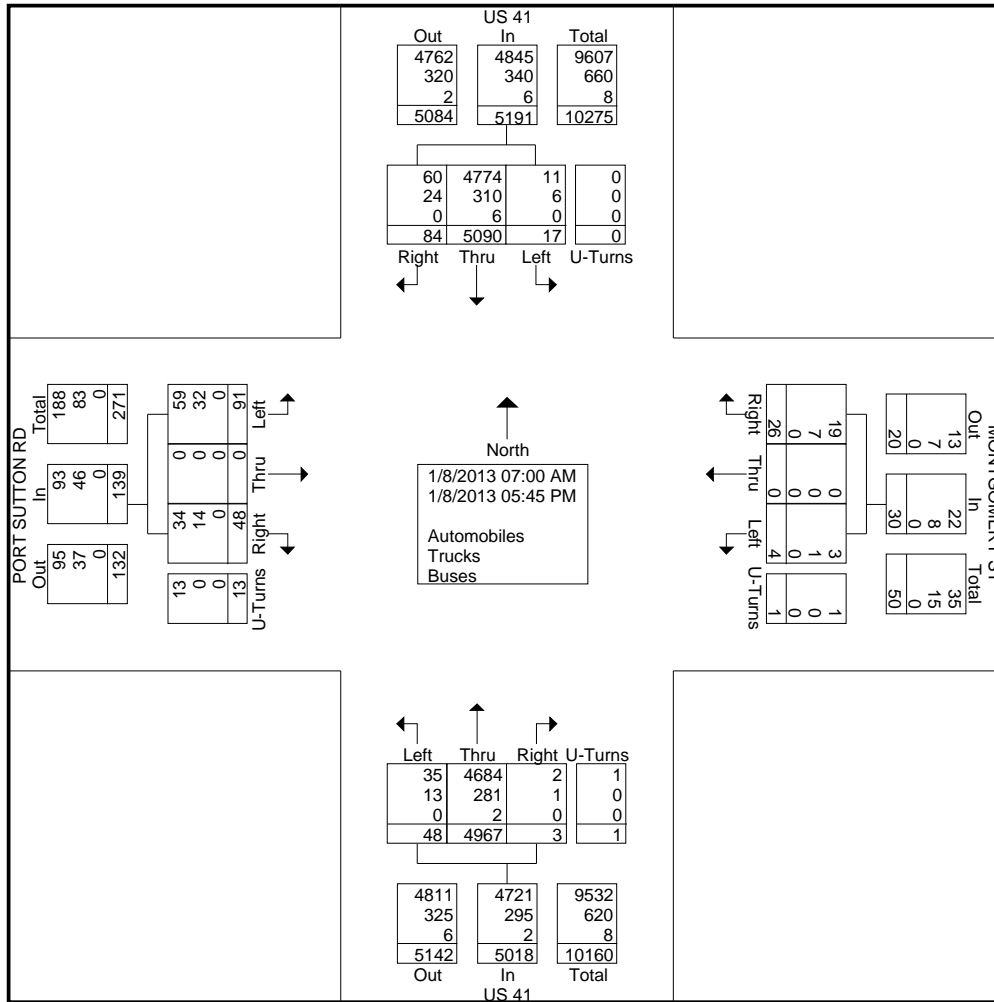



# Southern Traffic Services, Inc.

2911 Westfield Rd  
Gulf Breeze, FL 32563  
1-800-786-3374

*Traffic is our only business!*

US 41 @ Port Sutton Rd  
Tampa, FL

File Name : 13015-10 US 41 @ Port Sutton Rd  
Site Code : 13015-10  
Start Date : 1/8/2013  
Page No : 3

Start Time	US 41 Southbound				MONTGOMERY ST Westbound				US 41 Northbound				PORT SUTTON RD Eastbound				Int. Total				
	Thru	Right	U-Turns	App. Total	Left	Thru	Right	U-Turns	App. Total	Left	Thru	Right	U-Turns	App. Total	Left	Thru		Right	U-Turns	App. Total	
Peak Hour Analysis From 07:00 AM to 11:45 AM - Peak 1 of 1																					
Peak Hour for Entire Intersection Begins at 07:00 AM																					
07:00 AM	2	149	13	0	164	0	0	2	0	1	10	590	0	0	600	3	0	2	0	5	770
07:15 AM	2	138	7	0	147	0	0	1	0	2	3	522	0	1	526	4	0	3	2	9	684
07:30 AM	2	126	8	0	136	0	0	1	0	1	5	546	0	0	551	5	0	1	0	6	694
07:45 AM	0	169	13	0	182	0	0	2	0	2	6	523	1	0	530	4	0	1	1	6	720
Total Volume	6	582	41	0	629	0	0	6	0	6	24	2181	1	1	2207	16	0	7	3	26	2868
% App. Total	1	92.5	6.5	0		0	0	100	0		1.1	98.8	0	0		61.5	0	26.9	11.5		
PHF	.750	.861	.788	.000	.864	.000	.000	.750	.000	.750	.600	.924	.250	.250	.920	.800	.000	.583	.375	.722	.931
Automobiles	6	495	28	0	529	0	0	2	0	2	19	2108	1	1	2129	9	0	3	3	15	2675
% Automobiles	100	85.1	68.3	0	84.1	0	0	33.3	0	33.3	79.2	96.7	100	100	96.5	56.3	0	42.9	100	57.7	93.3
Trucks	0	84	13	0	97	0	0	4	0	4	5	72	0	0	77	7	0	4	0	11	189
% Trucks	0	14.4	31.7	0	15.4	0	0	66.7	0	66.7	20.8	3.3	0	0	3.5	43.8	0	57.1	0	42.3	6.6
Buses	0	3	0	0	3	0	0	0	0	0	0	1	0	0	1	0	0	0	0	0	4
% Buses	0	0.5	0	0	0.5	0	0	0	0	0	0	0.0	0	0	0.0	0	0	0	0	0	0.1

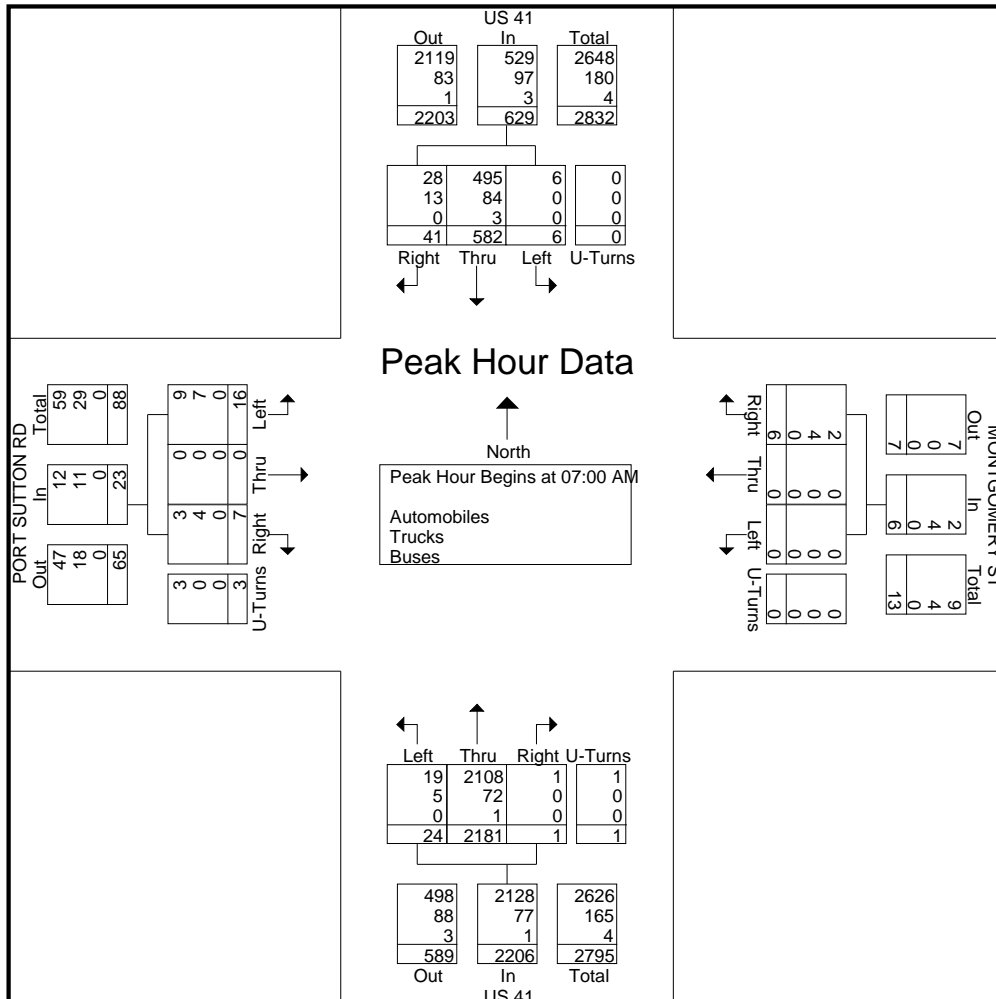





# Southern Traffic Services, Inc.

2911 Westfield Rd  
 Gulf Breeze, FL 32563  
 1-800-786-3374

*Traffic is our only business!*

US 41 @ Port Sutton Rd  
 Tampa, FL

File Name : 13015-10 US 41 @ Port Sutton Rd  
 Site Code : 13015-10  
 Start Date : 1/8/2013  
 Page No : 4

Start Time	US 41 Southbound					MONTGOMERY ST Westbound					US 41 Northbound					PORT SUTTON RD Eastbound					Int. Total
	Left	Thru	Right	U-Turns	App. Total	Left	Thru	Right	U-Turns	App. Total	Left	Thru	Right	U-Turns	App. Total	Left	Thru	Right	U-Turns	App. Total	

Peak Hour Analysis From 12:00 PM to 05:45 PM - Peak 1 of 1

Peak Hour for Entire Intersection Begins at 05:00 PM

05:00 PM	1	558	2	0	561	0	0	4	0	4	0	192	0	0	192	6	0	6	2	14	771
05:15 PM	0	544	0	0	544	1	0	2	0	3	0	184	0	0	184	3	0	1	2	6	737
05:30 PM	0	542	0	0	542	0	0	2	0	2	0	181	0	0	181	0	0	1	2	3	728
05:45 PM	0	514	1	0	515	0	0	0	0	0	3	179	0	0	182	1	0	1	1	3	700
Total Volume	1	2158	3	0	2162	1	0	8	0	9	3	736	0	0	739	10	0	9	7	26	2936
% App. Total	0	99.8	0.1	0		11.1	0	88.9	0		0.4	99.6	0	0		38.5	0	34.6	26.9		
PHF	.250	.967	.375	.000	.963	.250	.000	.500	.000	.563	.250	.958	.000	.000	.962	.417	.000	.375	.875	.464	.952
Automobiles	0	2109	2	0	2111	1	0	8	0	9	2	688	0	0	690	10	0	9	7	26	2836
% Automobiles	0	97.7	66.7	0	97.6	100	0	100	0	100	66.7	93.5	0	0	93.4	100	0	100	100	100	96.6
Trucks	1	48	1	0	50	0	0	0	0	0	1	47	0	0	48	0	0	0	0	0	98
% Trucks	100	2.2	33.3	0	2.3	0	0	0	0	0	33.3	6.4	0	0	6.5	0	0	0	0	0	3.3
Buses	0	1	0	0	1	0	0	0	0	0	0	1	0	0	1	0	0	0	0	0	2
% Buses	0	0.0	0	0	0.0	0	0	0	0	0	0	0.1	0	0	0.1	0	0	0	0	0	0.1

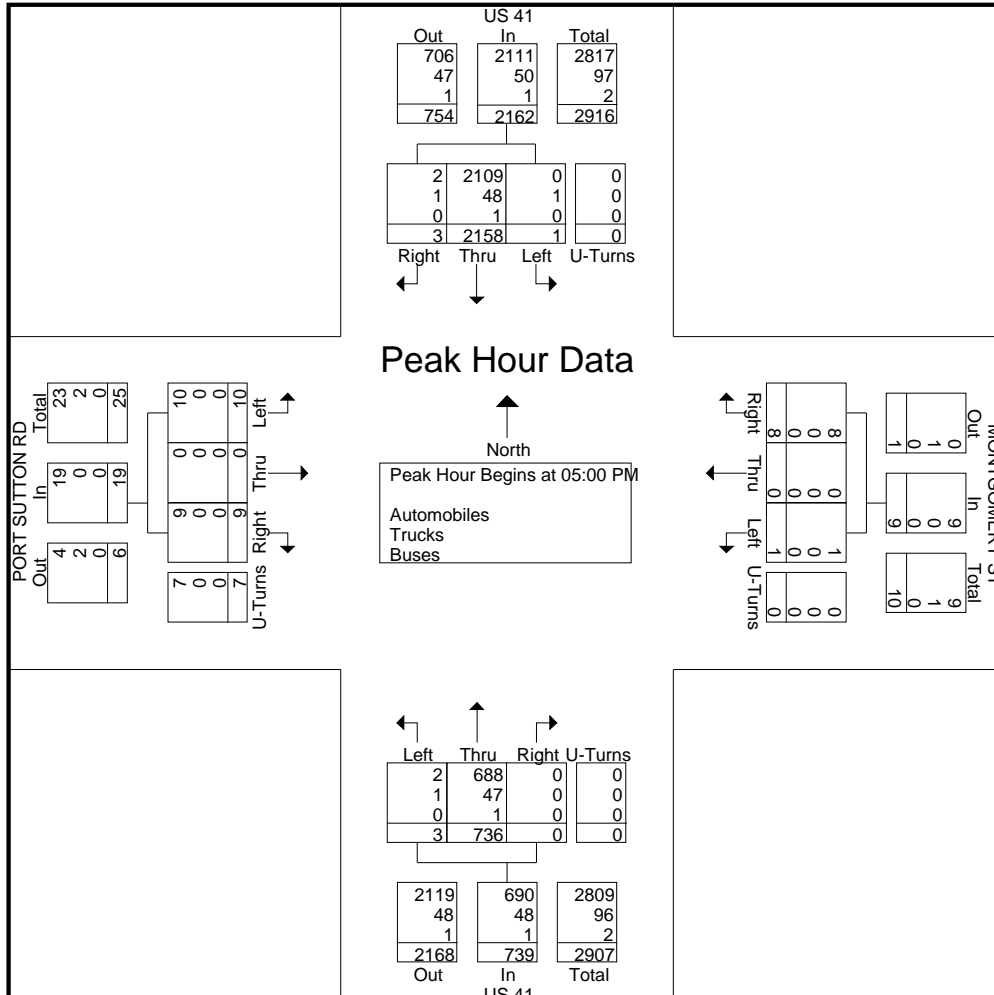



# Southern Traffic Services, Inc.

2911 Westfield Rd  
 Gulf Breeze, FL 32563  
 1-800-786-3374

*Traffic is our only business!*

US 41 @ Port Sutton Rd  
 Tampa, FL

File Name : 13015-10 US 41 @ Port Sutton Rd  
 Site Code : 13015-10  
 Start Date : 1/8/2013  
 Page No : 1

Groups Printed- Automobiles

Start Time	US 41 Southbound				MONTGOMERY ST Westbound				US 41 Northbound				PORT SUTTON RD Eastbound				Int. Total
	Left	Thru	Right	U-Turns	Left	Thru	Right	U-Turns	Left	Thru	Right	U-Turns	Left	Thru	Right	U-Turns	
07:00 AM	2	128	11	0	0	0	0	0	10	568	0	0	3	0	2	0	724
07:15 AM	2	116	5	0	0	0	0	0	1	509	0	1	2	0	1	2	639
07:30 AM	2	107	6	0	0	0	0	0	4	525	0	0	2	0	0	0	646
07:45 AM	0	144	6	0	0	0	2	0	4	506	1	0	2	0	0	1	666
Total	6	495	28	0	0	0	2	0	19	2108	1	1	9	0	3	3	2675
08:00 AM	0	150	6	0	0	0	1	0	2	393	1	0	7	0	1	1	562
08:15 AM	0	144	3	0	0	0	0	0	2	299	0	0	1	0	2	0	451
08:30 AM	1	104	2	0	0	0	1	0	3	326	0	0	1	0	2	0	440
08:45 AM	0	97	6	0	0	0	0	0	3	237	0	0	3	0	2	0	348
Total	1	495	17	0	0	0	2	0	10	1255	1	0	12	0	7	1	1801
<b>**BREAK**</b>																	
04:00 PM	2	331	2	0	0	0	1	0	1	162	0	0	7	0	7	2	515
04:15 PM	1	429	3	0	2	0	2	1	1	160	0	0	11	0	3	0	613
04:30 PM	1	443	6	0	0	0	2	0	2	152	0	0	3	0	3	0	612
04:45 PM	0	472	2	0	0	0	2	0	0	159	0	0	7	0	2	0	644
Total	4	1675	13	0	2	0	7	1	4	633	0	0	28	0	15	2	2384
05:00 PM	0	548	1	0	0	0	4	0	0	176	0	0	6	0	6	2	743
05:15 PM	0	528	0	0	1	0	2	0	0	173	0	0	3	0	1	2	710
05:30 PM	0	530	0	0	0	0	2	0	0	171	0	0	0	0	1	2	706
05:45 PM	0	503	1	0	0	0	0	0	2	168	0	0	1	0	1	1	677
Total	0	2109	2	0	1	0	8	0	2	688	0	0	10	0	9	7	2836
Grand Total	11	4774	60	0	3	0	19	1	35	4684	2	1	59	0	34	13	9696
Apprch %	0.2	98.5	1.2	0	13	0	82.6	4.3	0.7	99.2	0	0	55.7	0	32.1	12.3	
Total %	0.1	49.2	0.6	0	0	0	0.2	0	0.4	48.3	0	0	0.6	0	0.4	0.1	



# Southern Traffic Services, Inc.

2911 Westfield Rd  
Gulf Breeze, FL 32563  
1-800-786-3374

*Traffic is our only business!*

US 41 @ Port Sutton Rd  
Tampa, FL

File Name : 13015-10 US 41 @ Port Sutton Rd  
Site Code : 13015-10  
Start Date : 1/8/2013  
Page No : 2

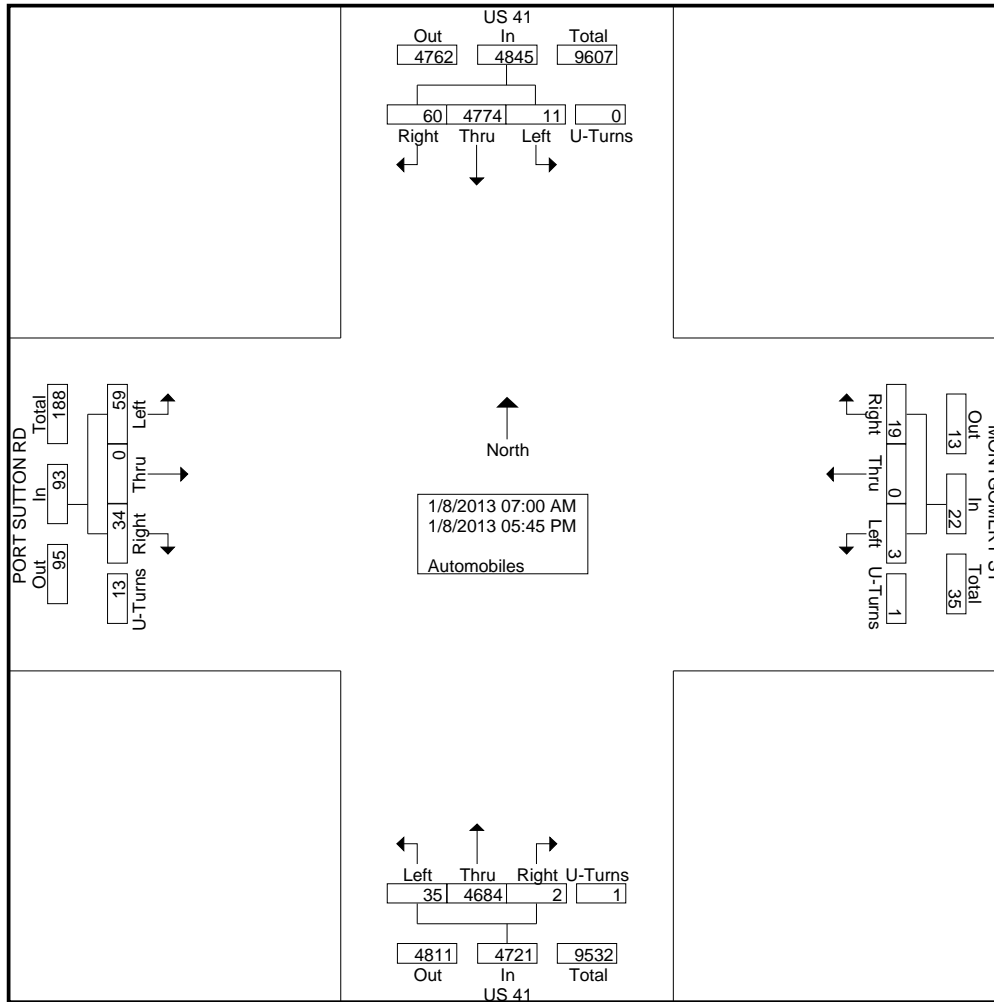



# Southern Traffic Services, Inc.

2911 Westfield Rd  
Gulf Breeze, FL 32563  
1-800-786-3374

*Traffic is our only business!*

US 41 @ Port Sutton Rd  
Tampa, FL

File Name : 13015-10 US 41 @ Port Sutton Rd  
Site Code : 13015-10  
Start Date : 1/8/2013  
Page No : 3

Start Time	US 41 Southbound				MONTGOMERY ST Westbound				US 41 Northbound				PORT SUTTON RD Eastbound				Int. Total				
	Thru	Right	U-Turns	App. Total	Left	Thru	Right	U-Turns	App. Total	Left	Thru	Right	U-Turns	App. Total	Left	Thru		Right	U-Turns	App. Total	
Peak Hour Analysis From 07:00 AM to 11:45 AM - Peak 1 of 1																					
Peak Hour for Entire Intersection Begins at 07:00 AM																					
07:00 AM	2	128	11	0	141	0	0	0	0	0	10	568	0	0	578	3	0	2	0	5	724
07:15 AM	2	116	5	0	123	0	0	0	0	0	1	509	0	1	511	2	0	1	2	5	639
07:30 AM	2	107	6	0	115	0	0	0	0	0	4	525	0	0	529	2	0	0	0	2	646
07:45 AM	0	144	6	0	150	0	0	2	0	2	4	506	1	0	511	2	0	0	1	3	666
Total Volume	6	495	28	0	529	0	0	2	0	2	19	2108	1	1	2129	9	0	3	3	15	2675
% App. Total	1.1	93.6	5.3	0		0	0	100	0		0.9	99	0	0		60	0	20	20		
PHF	.750	.859	.636	.000	.882	.000	.000	.250	.000	.250	.475	.928	.250	.250	.921	.750	.000	.375	.375	.750	.924

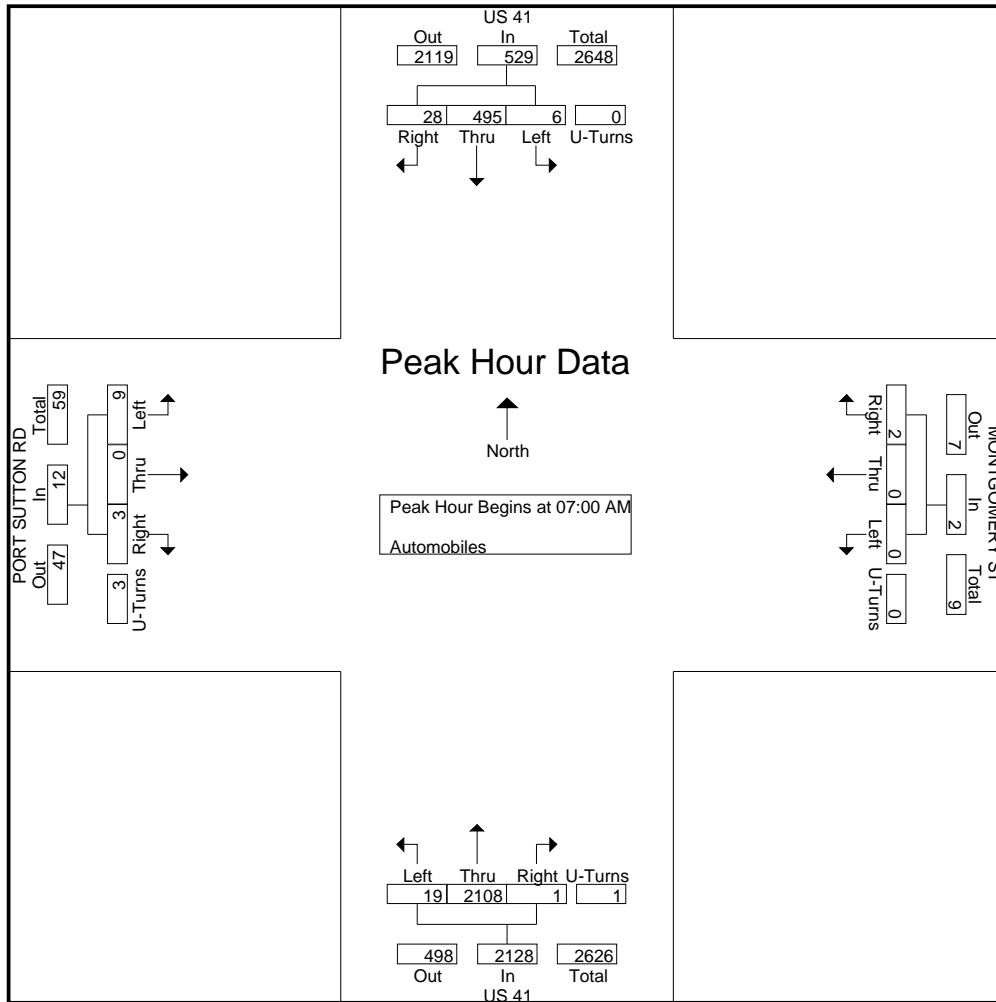



# Southern Traffic Services, Inc.

2911 Westfield Rd  
 Gulf Breeze, FL 32563  
 1-800-786-3374

*Traffic is our only business!*

US 41 @ Port Sutton Rd  
 Tampa, FL

File Name : 13015-10 US 41 @ Port Sutton Rd  
 Site Code : 13015-10  
 Start Date : 1/8/2013  
 Page No : 4

Start Time	US 41 Southbound					MONTGOMERY ST Westbound					US 41 Northbound					PORT SUTTON RD Eastbound					Int. Total
	Left	Thru	Right	U-Turns	App. Total	Left	Thru	Right	U-Turns	App. Total	Left	Thru	Right	U-Turns	App. Total	Left	Thru	Right	U-Turns	App. Total	
Peak Hour Analysis From 12:00 PM to 05:45 PM - Peak 1 of 1																					
Peak Hour for Entire Intersection Begins at 05:00 PM																					
05:00 PM	0	548	1	0	549	0	0	4	0	4	0	176	0	0	176	6	0	6	2	14	743
05:15 PM	0	528	0	0	528	1	0	2	0	3	0	173	0	0	173	3	0	1	2	6	710
05:30 PM	0	530	0	0	530	0	0	2	0	2	0	171	0	0	171	0	0	1	2	3	706
05:45 PM	0	503	1	0	504	0	0	0	0	0	2	168	0	0	170	1	0	1	1	3	677
Total Volume	0	2109	2	0	2111	1	0	8	0	9	2	688	0	0	690	10	0	9	7	26	2836
% App. Total	0	99.9	0.1	0		11.1	0	88.9	0		0.3	99.7	0	0		38.5	0	34.6	26.9		
PHF	.000	.962	.500	.000	.961	.250	.000	.500	.000	.563	.250	.977	.000	.000	.980	.417	.000	.375	.875	.464	.954

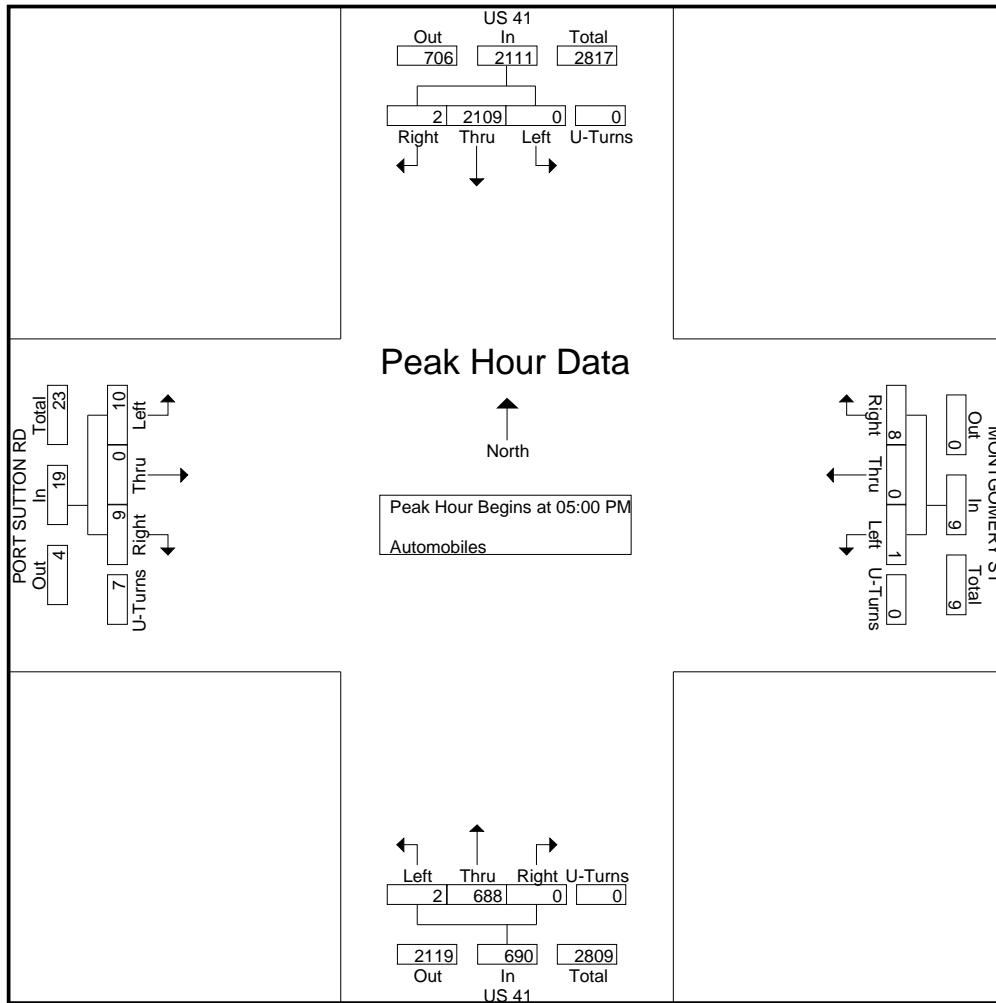





# Southern Traffic Services, Inc.

2911 Westfield Rd  
 Gulf Breeze, FL 32563  
 1-800-786-3374

*Traffic is our only business!*

US 41 @ Port Sutton Rd  
 Tampa, FL

File Name : 13015-10 US 41 @ Port Sutton Rd  
 Site Code : 13015-10  
 Start Date : 1/8/2013  
 Page No : 2

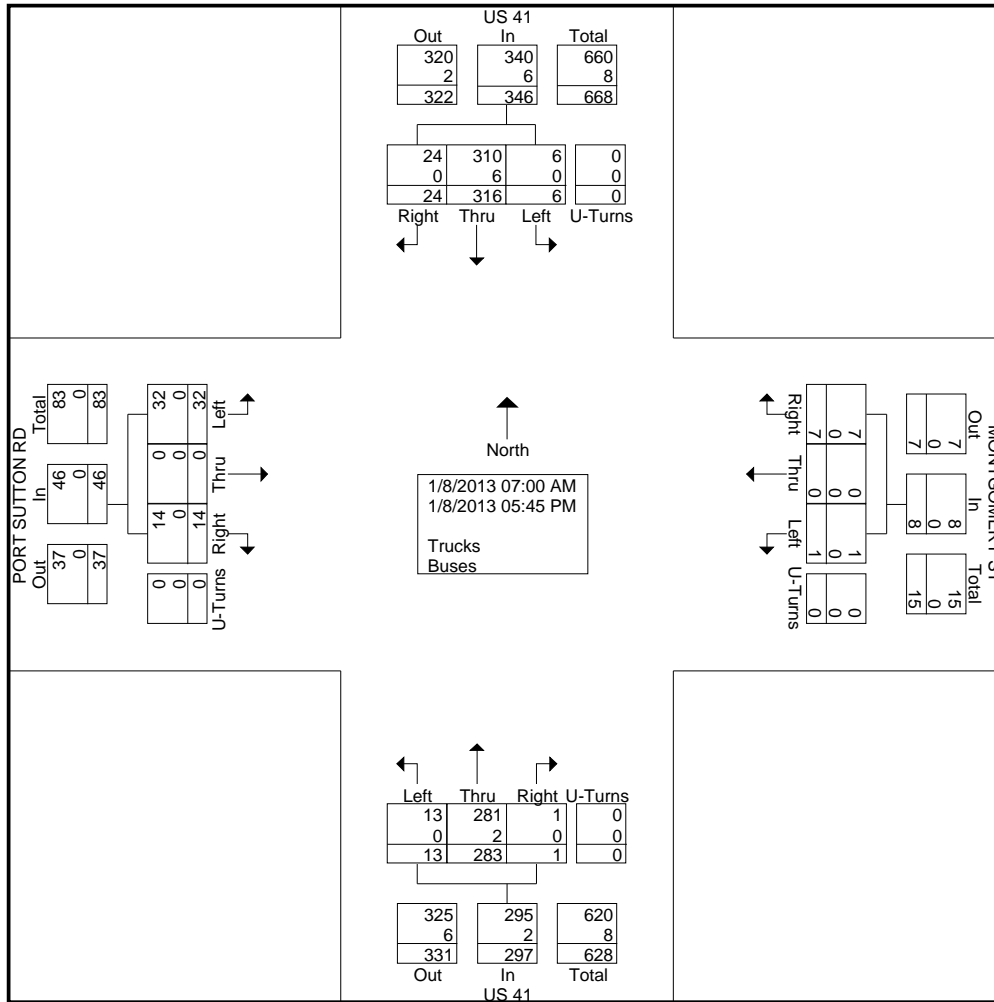



# Southern Traffic Services, Inc.

2911 Westfield Rd  
Gulf Breeze, FL 32563  
1-800-786-3374

*Traffic is our only business!*

US 41 @ Port Sutton Rd  
Tampa, FL

File Name : 13015-10 US 41 @ Port Sutton Rd  
Site Code : 13015-10  
Start Date : 1/8/2013  
Page No : 3

Start Time	US 41 Southbound				MONTGOMERY ST Westbound				US 41 Northbound				PORT SUTTON RD Eastbound				Int. Total				
	Thru	Right	U-Turns	App. Total	Left	Thru	Right	U-Turns	App. Total	Left	Thru	Right	U-Turns	App. Total	Left	Thru		Right	U-Turns	App. Total	
Peak Hour Analysis From 07:00 AM to 11:45 AM - Peak 1 of 1																					
Peak Hour for Entire Intersection Begins at 08:00 AM																					
08:00 AM	0	33	2	0	35	0	0	1	0	1	1	20	0	0	21	6	0	0	0	6	63
08:15 AM	1	27	3	0	31	0	0	1	0	1	2	24	0	0	26	6	0	1	0	7	65
08:30 AM	0	25	2	0	27	0	0	0	0	0	2	20	0	0	22	3	0	2	0	5	54
08:45 AM	0	31	3	0	34	1	0	1	0	2	0	29	0	0	29	2	0	3	0	5	70
Total Volume	1	116	10	0	127	1	0	3	0	4	5	93	0	0	98	17	0	6	0	23	252
% App. Total	0.8	91.3	7.9	0		25	0	75	0		5.1	94.9	0	0		73.9	0	26.1	0		
PHF	.250	.879	.833	.000	.907	.250	.000	.750	.000	.500	.625	.802	.000	.000	.845	.708	.000	.500	.000	.821	.900

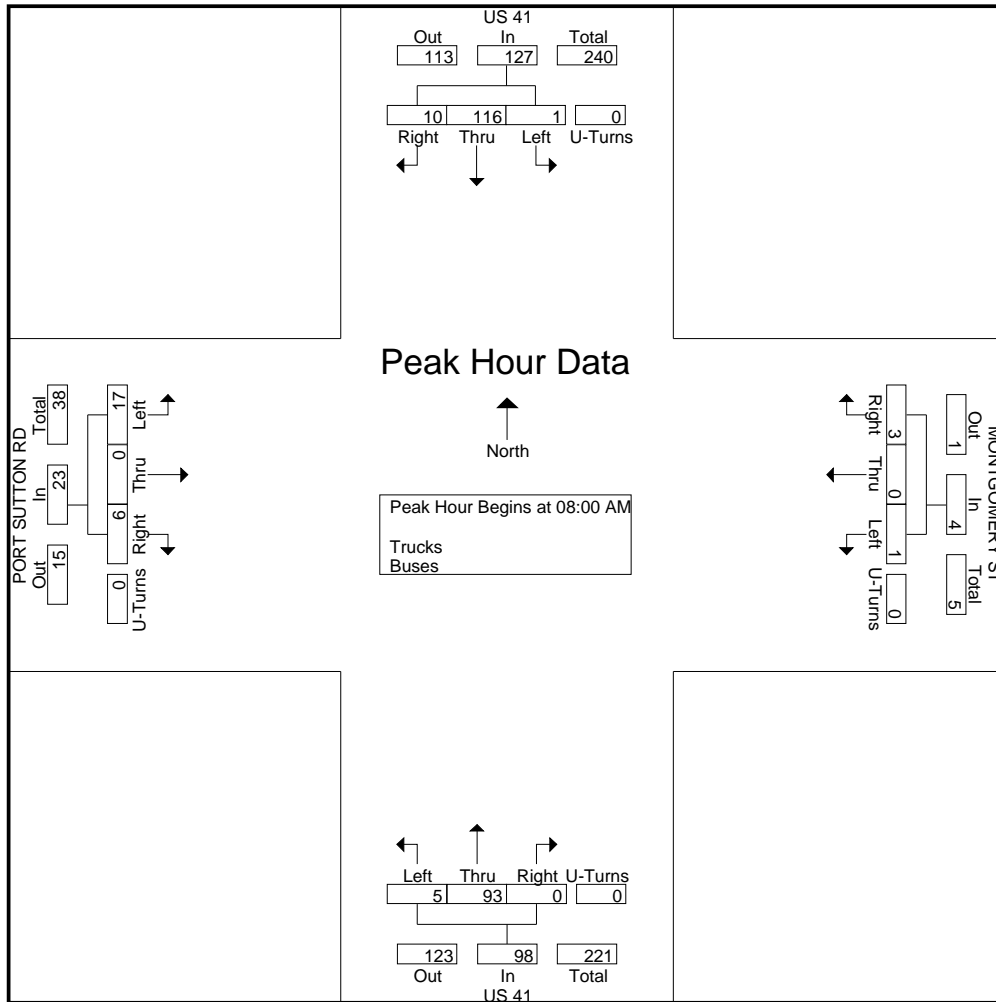





# Southern Traffic Services, Inc.

2911 Westfield Rd  
Gulf Breeze, FL 32563  
1-800-786-3374

*Traffic is our only business!*

US 41 @ Port Sutton Rd  
Tampa, FL

File Name : 13015-10 US 41 @ Port Sutton Rd  
Site Code : 13015-10  
Start Date : 1/8/2013  
Page No : 4

Start Time	US 41 Southbound					MONTGOMERY ST Westbound					US 41 Northbound					PORT SUTTON RD Eastbound					Int. Total
	Left	Thru	Right	U-Turns	App. Total	Left	Thru	Right	U-Turns	App. Total	Left	Thru	Right	U-Turns	App. Total	Left	Thru	Right	U-Turns	App. Total	
Peak Hour Analysis From 12:00 PM to 05:45 PM - Peak 1 of 1																					
Peak Hour for Entire Intersection Begins at 04:00 PM																					
04:00 PM	0	23	0	0	23	0	0	0	0	0	0	21	0	0	21	2	0	1	0	3	47
04:15 PM	2	16	0	0	18	0	0	0	0	0	1	16	1	0	18	4	0	1	0	5	41
04:30 PM	1	11	0	0	12	0	0	0	0	0	1	20	0	0	21	1	0	0	0	1	34
04:45 PM	1	14	0	0	15	0	0	0	0	0	0	12	0	0	12	1	0	2	0	3	30
Total Volume	4	64	0	0	68	0	0	0	0	0	2	69	1	0	72	8	0	4	0	12	152
% App. Total	5.9	94.1	0	0		0	0	0	0		2.8	95.8	1.4	0		66.7	0	33.3	0		
PHF	.500	.696	.000	.000	.739	.000	.000	.000	.000	.000	.500	.821	.250	.000	.857	.500	.000	.500	.000	.600	.809

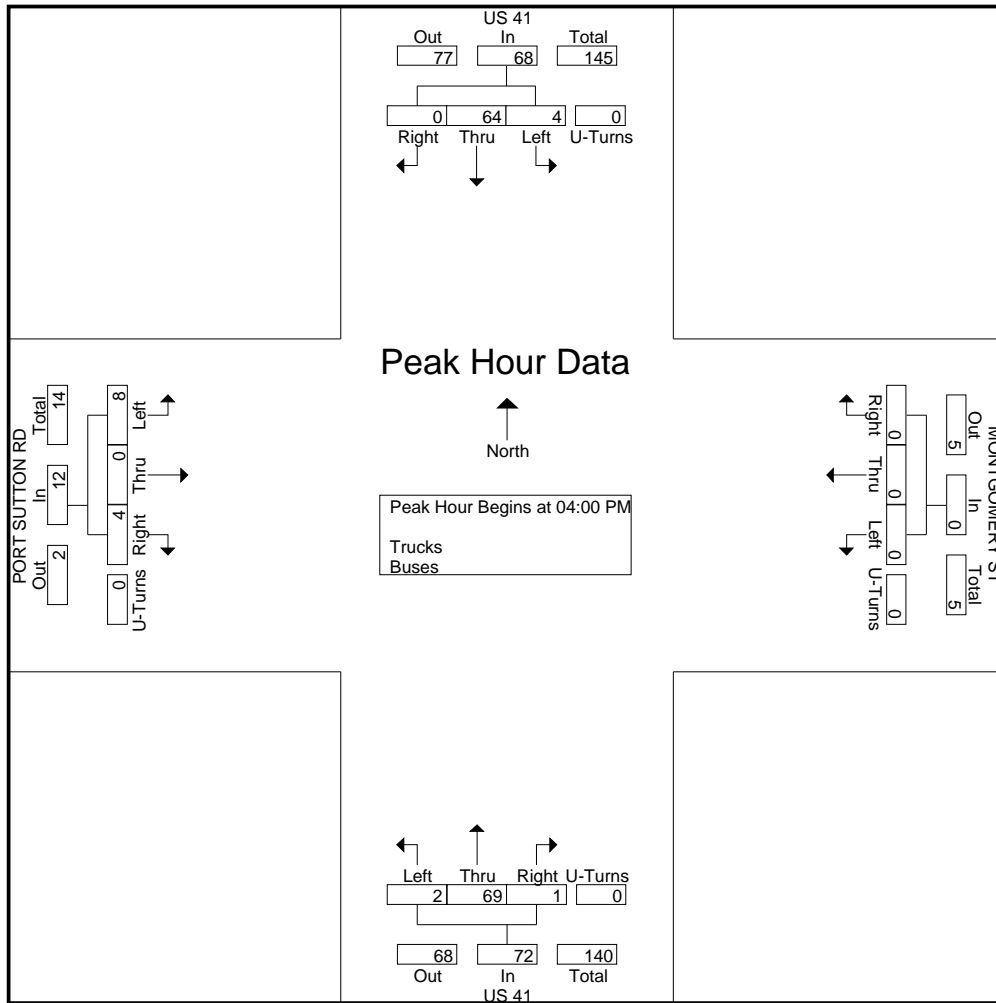



# Southern Traffic Services, Inc.

2911 Westfield Rd  
Gulf Breeze, FL 32563  
1-800-786-3374

*Traffic is our only business!*

US 41 @ Port Sutton Rd  
Tampa, FL

File Name : 13015-10 US 41 @ Port Sutton Rd Peds  
Site Code : 13015-10  
Start Date : 1/8/2013  
Page No : 1

Groups Printed- Peds

	US 41 Southbound	MONTGOMERY ST Westbound	US 41 Northbound	PORT SUTTON RD Eastbound	Int. Total
Start Time	Peds	Peds	Peds	Peds	
07:00 AM	0	0	0	0	0
07:15 AM	0	0	0	0	0
07:30 AM	0	0	0	0	0
07:45 AM	0	0	0	0	0
Total	0	0	0	0	0
08:00 AM	0	0	0	0	0
08:15 AM	0	0	1	0	1
08:30 AM	0	0	0	1	1
08:45 AM	0	0	0	0	0
Total	0	0	1	1	2
09:00 AM	0	0	0	0	0
09:15 AM	0	0	0	0	0
09:30 AM	0	0	0	0	0
09:45 AM	0	0	0	0	0
Total	0	0	0	0	0
10:00 AM	0	0	0	0	0
10:15 AM	0	0	0	0	0
10:30 AM	0	0	0	0	0
10:45 AM	0	0	0	0	0
Total	0	0	0	0	0
11:00 AM	0	0	0	0	0
11:15 AM	0	0	0	0	0
11:30 AM	0	0	0	0	0
11:45 AM	0	0	0	0	0
Total	0	0	0	0	0
12:00 PM	0	0	0	0	0
12:15 PM	0	0	0	0	0
12:30 PM	0	0	0	0	0
12:45 PM	0	0	0	0	0
Total	0	0	0	0	0
01:00 PM	0	0	0	0	0
01:15 PM	0	0	0	0	0
01:30 PM	0	0	0	0	0
01:45 PM	0	0	0	0	0
Total	0	0	0	0	0
02:00 PM	0	0	0	0	0
02:15 PM	0	0	0	0	0
02:30 PM	0	0	0	0	0
02:45 PM	0	0	0	0	0
Total	0	0	0	0	0
03:00 PM	0	0	0	0	0
03:15 PM	0	0	0	0	0
03:30 PM	0	0	0	0	0
03:45 PM	0	0	0	0	0
Total	0	0	0	0	0



# Southern Traffic Services, Inc.

2911 Westfield Rd  
 Gulf Breeze, FL 32563  
 1-800-786-3374

*Traffic is our only business!*

US 41 @ Port Sutton Rd  
 Tampa, FL

File Name : 13015-10 US 41 @ Port Sutton Rd Peds  
 Site Code : 13015-10  
 Start Date : 1/8/2013  
 Page No : 2

Groups Printed- Peds

	US 41 Southbound	MONTGOMERY ST Westbound	US 41 Northbound	PORT SUTTON RD Eastbound	Int. Total
Start Time	Peds	Peds	Peds	Peds	
04:00 PM	0	0	0	0	0
04:15 PM	0	0	0	0	0
04:30 PM	1	0	0	0	1
04:45 PM	0	0	0	0	0
<b>Total</b>	<b>1</b>	<b>0</b>	<b>0</b>	<b>0</b>	<b>1</b>
05:00 PM	0	1	0	2	3
05:15 PM	0	0	1	0	1
05:30 PM	0	0	0	0	0
05:45 PM	0	0	0	0	0
<b>Total</b>	<b>0</b>	<b>1</b>	<b>1</b>	<b>2</b>	<b>4</b>
<b>Grand Total</b>	<b>1</b>	<b>1</b>	<b>2</b>	<b>3</b>	<b>7</b>
Apprch %	100	100	100	100	
Total %	14.3	14.3	28.6	42.9	

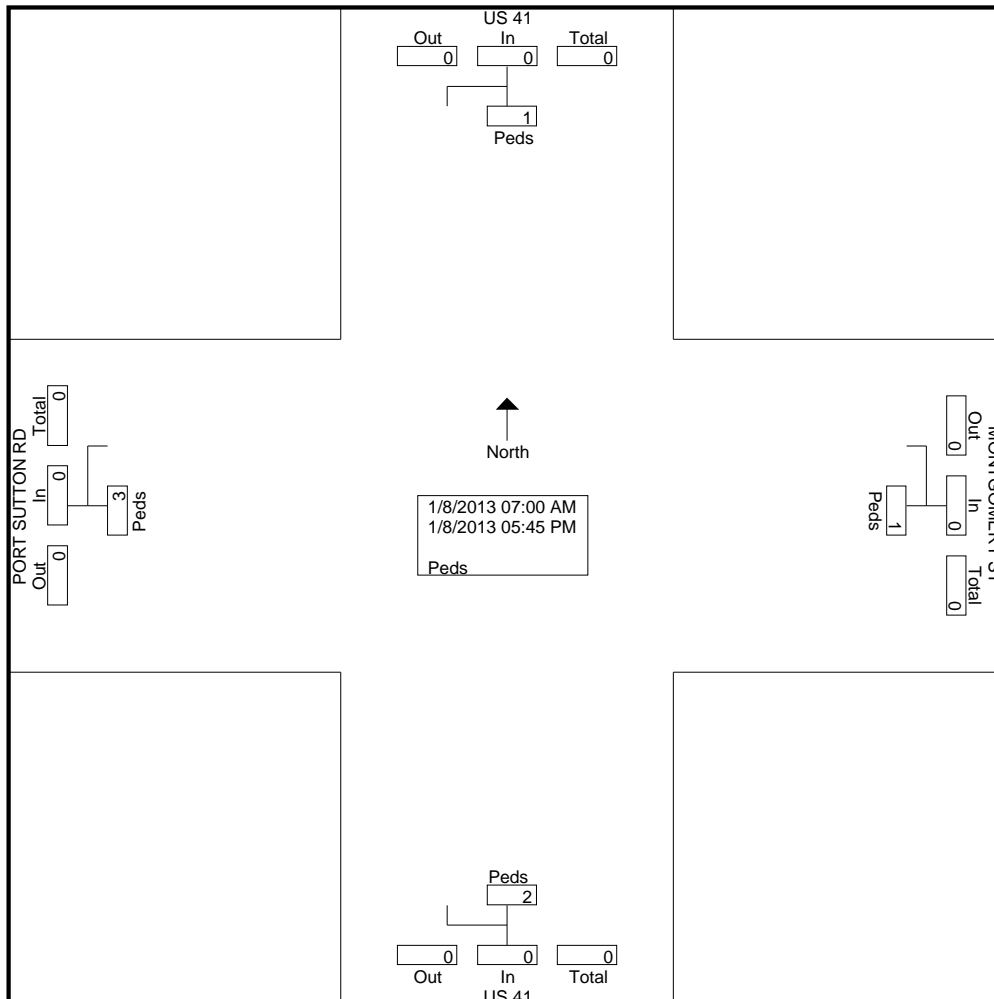

# Southern Traffic Services, Inc.

## Event Counts

**US 41 north of Port Sutton Road**

**Northbound**

**Datasets:**

**Site:** [101] I6011  
**Input A:** 5 - South bound A>B, North bound B>A. - Excluded from totals. (0)  
**Input B:** 0 - Unused or unknown. - Added to totals. (1)  
**Survey Duration:** 12:02 Monday, January 07, 2013 => 12:17 Friday, January 11, 2013  
**File:** G:\DATA\2013\Private\13015\diego\Data 1-7-13\UM101.eco (Plus)  
**Identifier:** S5002K8C MC56-L5 [MC55] (c)Microcom 19Oct04  
**Algorithm:** Event Count  
**Data type:** Axle sensors - Paired (Class, Speed, Count)

**Profile:**

**Filter time:** 0:00 Tuesday, January 08, 2013 => 0:00 Friday, January 11, 2013  
**Name:** Factory default profile  
**Scheme:** Count events divided by two.  
**Units:** Non metric (ft, mi, ft/s, mph, lb, ton)  
**In profile:** Events = 47684

**Tuesday, January 08, 2013=15823, 15 minute drops**

0000	0100	0200	0300	0400	0500	0600	0700	0800	0900	1000	1100	1200	1300	1400	1500	1600	1700	1800	1900	2000	2100	2200	2300	
61	58	51	136	256	688	1517	2326	1506	966	865	851	858	827	838	921	808	789	566	296	212	185	147	95	
14	17	13	27	38	114	275	609	446	250	233	217	216	207	166	237	225	238	166	93	44	46	44	30	16
13	14	11	24	46	156	373	552	400	268	207	230	203	133	232	207	192	176	168	73	47	43	46	20	25
16	16	20	45	77	190	278	607	383	222	209	187	225	251	215	293	214	202	130	79	69	49	31	26	20
18	11	7	40	95	228	591	558	277	226	216	217	214	236	225	184	177	173	102	51	52	47	26	19	14

AM Peak 0645 - 0745 (2359), AM PHF=0.97 PM Peak 1445 - 1545 (962), PM PHF=0.82

**Wednesday, January 09, 2013=15938, 15 minute drops**

0000	0100	0200	0300	0400	0500	0600	0700	0800	0900	1000	1100	1200	1300	1400	1500	1600	1700	1800	1900	2000	2100	2200	2300	
75	63	83	123	258	742	1625	2173	1493	923	854	684	922	823	864	950	866	774	611	319	204	239	166	104	
16	18	36	15	48	113	294	516	466	264	249	192	264	186	247	255	236	227	142	94	48	70	54	39	23
25	19	12	30	49	150	388	539	387	232	203	179	192	231	220	197	228	178	166	94	50	55	43	25	12
20	13	23	39	74	225	482	574	377	203	199	176	249	181	199	269	220	180	163	78	52	64	42	18	11
14	13	12	39	87	254	461	544	263	224	203	137	217	225	198	229	182	189	140	53	54	50	27	22	11

AM Peak 0700 - 0800 (2173), AM PHF=0.95 PM Peak 1530 - 1630 (962), PM PHF=0.89

**Thursday, January 10, 2013=15923, 15 minute drops**

0000	0100	0200	0300	0400	0500	0600	0700	0800	0900	1000	1100	1200	1300	1400	1500	1600	1700	1800	1900	2000	2100	2200	2300	
57	56	60	90	255	754	1581	2170	1468	946	778	870	812	848	871	1024	851	778	585	345	237	202	178	107	
23	24	12	12	26	127	289	500	421	249	178	228	215	227	226	267	235	199	168	131	59	58	47	15	15
12	4	17	27	65	165	364	546	447	235	218	208	182	207	228	246	229	212	176	92	62	57	55	42	18
11	19	17	30	84	222	393	576	318	233	177	216	207	220	198	296	203	188	147	71	73	49	47	27	9
11	9	14	21	80	240	535	548	282	229	205	218	208	194	219	215	184	179	94	51	43	38	29	23	13

AM Peak 0700 - 0800 (2170), AM PHF=0.94 PM Peak 1445 - 1545 (1028), PM PHF=0.87

# Southern Traffic Services, Inc.

## Event Counts

**US 41 north of Port Sutton Road**

**Southbound**

**Datasets:**

**Site:** [101] I6011  
**Input A:** 5 - South bound A>B, North bound B>A. - Added to totals. (1)  
**Input B:** 0 - Unused or unknown. - Excluded from totals. (0)  
**Survey Duration:** 12:02 Monday, January 07, 2013 => 12:17 Friday, January 11, 2013  
**File:** G:\DATA\2013\Private\13015\diego\Data 1-7-13\UM101.eco (Plus)  
**Identifier:** S5002K8C MC56-L5 [MC55] (c)Microcom 19Oct04  
**Algorithm:** Event Count  
**Data type:** Axle sensors - Paired (Class, Speed, Count)

**Profile:**

**Filter time:** 0:00 Tuesday, January 08, 2013 => 0:00 Friday, January 11, 2013  
**Name:** Factory default profile  
**Scheme:** Count events divided by two.  
**Units:** Non metric (ft, mi, ft/s, mph, lb, ton)  
**In profile:** Events = 50377

**Tuesday, January 08, 2013=16739, 15 minute drops**

0000	0100	0200	0300	0400	0500	0600	0700	0800	0900	1000	1100	1200	1300	1400	1500	1600	1700	1800	1900	2000	2100	2200	2300	
193	101	92	109	162	348	632	715	737	667	681	793	796	840	761	1501	1853	2136	1419	752	531	383	305	232	
85	26	23	13	38	40	139	183	208	186	160	192	211	182	223	349	372	538	448	224	151	97	110	58	26
51	31	25	27	26	78	158	176	222	158	185	188	190	240	232	336	443	546	387	170	164	95	79	69	28
30	18	23	32	40	112	166	145	156	174	174	187	208	223	213	405	521	535	334	183	116	102	71	55	29
27	26	21	37	58	118	169	211	151	149	162	226	187	195	93	411	517	517	250	175	100	89	45	50	19

AM Peak 1145 - 1245 (835), AM PHF=0.92 PM Peak 1645 - 1745 (2136), PM PHF=0.98

**Wednesday, January 09, 2013=16779, 15 minute drops**

0000	0100	0200	0300	0400	0500	0600	0700	0800	0900	1000	1100	1200	1300	1400	1500	1600	1700	1800	1900	2000	2100	2200	2300	
102	127	90	98	159	413	590	820	712	693	661	810	736	798	963	1344	1820	2175	1359	663	538	459	367	282	
26	39	28	24	39	54	149	242	162	161	168	193	162	190	237	282	424	587	412	146	149	129	104	73	45
28	29	31	29	31	89	105	200	210	187	148	194	186	219	220	330	447	528	413	183	145	100	109	67	42
29	34	16	29	50	133	231	180	172	172	175	216	209	180	254	325	465	539	293	192	123	131	65	72	29
19	25	15	16	39	137	105	198	168	173	170	207	179	209	252	407	484	521	241	142	121	99	89	70	38

AM Peak 0700 - 0800 (820), AM PHF=0.85 PM Peak 1700 - 1800 (2175), PM PHF=0.93

**Thursday, January 10, 2013=16859, 15 minute drops**

0000	0100	0200	0300	0400	0500	0600	0700	0800	0900	1000	1100	1200	1300	1400	1500	1600	1700	1800	1900	2000	2100	2200	2300	
154	96	104	102	182	323	698	731	554	744	682	745	868	798	987	1356	1811	2107	1428	745	581	420	385	258	
45	37	31	21	40	51	159	167	152	268	136	162	190	196	231	287	423	509	371	246	141	102	95	73	47
42	26	21	19	37	64	171	194	166	128	164	124	263	137	251	310	445	578	426	199	174	136	108	59	53
29	25	26	28	40	104	123	183	168	159	194	250	224	258	236	378	445	558	356	166	121	84	92	72	50
38	8	26	34	65	104	245	187	68	189	188	209	191	207	269	381	498	462	275	134	145	98	90	54	18

AM Peak 1130 - 1230 (912), AM PHF=0.87 PM Peak 1645 - 1745 (2143), PM PHF=0.93

# Southern Traffic Services, Inc.

## Event Counts

**US 41 south of Port Sutton Road**

**Northbound**

**Datasets:**

**Site:** [091] I9008  
**Input A:** 5 - South bound A>B, North bound B>A. - Excluded from totals. (0)  
**Input B:** 0 - Unused or unknown. - Added to totals. (1)  
**Survey Duration:** 12:00 Monday, January 07, 2013 => 12:33 Friday, January 11, 2013  
**File:** G:\DATA\2013\Private\13015\diego\Data 1-7-13\UM091.eco (Plus)  
**Identifier:** AQ656QPJ MC56-L5 [MC55] (c)Microcom 19Oct04  
**Algorithm:** Event Count  
**Data type:** Axle sensors - Paired (Class, Speed, Count)

**Profile:**

**Filter time:** 0:00 Tuesday, January 08, 2013 => 0:00 Friday, January 11, 2013  
**Name:** Factory default profile  
**Scheme:** Count events divided by two.  
**Units:** Non metric (ft, mi, ft/s, mph, lb, ton)  
**In profile:** Events = 48695

**Tuesday, January 08, 2013=16110, 15 minute drops**

0000	0100	0200	0300	0400	0500	0600	0700	0800	0900	1000	1100	1200	1300	1400	1500	1600	1700	1800	1900	2000	2100	2200	2300	
69	62	54	143	257	705	1604	2382	1477	992	900	850	871	866	833	957	803	791	570	288	212	185	147	92	
17	17	14	29	38	116	302	650	433	243	243	198	215	232	175	241	220	225	172	88	46	48	43	28	20
14	17	12	28	47	161	385	581	379	278	207	248	231	131	231	238	184	177	165	74	48	39	45	21	21
20	14	17	44	82	191	287	602	382	236	221	197	230	270	201	293	217	205	131	76	68	48	35	25	21
18	14	11	42	90	237	630	549	283	235	229	207	195	233	226	185	182	184	102	50	50	50	24	18	12

AM Peak 0645 - 0745 (2463), AM PHF=0.95 PM Peak 1445 - 1545 (998), PM PHF=0.85

**Wednesday, January 09, 2013=16305, 15 minute drops**

0000	0100	0200	0300	0400	0500	0600	0700	0800	0900	1000	1100	1200	1300	1400	1500	1600	1700	1800	1900	2000	2100	2200	2300	
74	61	87	125	267	760	1738	2244	1536	962	909	691	930	799	862	925	891	794	614	318	201	238	171	108	
20	22	38	17	48	111	311	529	478	288	271	202	276	176	248	228	231	239	147	91	49	66	54	39	24
21	14	11	34	48	151	416	554	407	240	202	176	191	226	224	187	230	178	169	99	49	60	47	28	13
21	13	25	36	79	244	508	601	377	217	211	183	253	170	198	271	237	184	163	78	48	63	43	20	11
12	12	13	38	92	254	503	560	274	217	225	130	210	227	192	239	193	193	135	50	55	49	27	21	12

AM Peak 0700 - 0800 (2244), AM PHF=0.93 PM Peak 1530 - 1630 (971), PM PHF=0.90

**Thursday, January 10, 2013=16280, 15 minute drops**

0000	0100	0200	0300	0400	0500	0600	0700	0800	0900	1000	1100	1200	1300	1400	1500	1600	1700	1800	1900	2000	2100	2200	2300	
60	60	67	93	258	766	1625	2243	1517	972	816	882	827	881	890	1027	873	786	602	316	238	197	180	104	
24	25	15	13	26	122	298	516	418	239	166	230	217	235	226	273	251	195	167	107	60	56	49	13	15
13	4	20	25	68	167	378	571	454	250	232	215	185	192	213	240	224	228	184	89	57	55	54	43	18
11	19	17	30	82	236	407	583	352	238	181	223	216	247	192	301	215	191	150	67	75	48	47	26	9
12	12	15	25	82	241	542	573	293	245	237	214	209	207	259	213	183	172	101	53	46	38	30	22	16

AM Peak 0700 - 0800 (2243), AM PHF=0.96 PM Peak 1445 - 1545 (1073), PM PHF=0.89

# Southern Traffic Services, Inc.

## Event Counts

**US 41 south of Port Sutton Road**

**Southbound**

**Datasets:**

**Site:** [091] I9008  
**Input A:** 5 - South bound A>B, North bound B>A. - Added to totals. (1)  
**Input B:** 0 - Unused or unknown. - Excluded from totals. (0)  
**Survey Duration:** 12:00 Monday, January 07, 2013 => 12:33 Friday, January 11, 2013  
**File:** G:\DATA\2013\Private\13015\diego\Data 1-7-13\UM091.eco (Plus)  
**Identifier:** AQ656QPJ MC56-L5 [MC55] (c)Microcom 19Oct04  
**Algorithm:** Event Count  
**Data type:** Axle sensors - Paired (Class, Speed, Count)

**Profile:**

**Filter time:** 0:00 Tuesday, January 08, 2013 => 0:00 Friday, January 11, 2013  
**Name:** Factory default profile  
**Scheme:** Count events divided by two.  
**Units:** Non metric (ft, mi, ft/s, mph, lb, ton)  
**In profile:** Events = 50877

**Tuesday, January 08, 2013=16803, 15 minute drops**

0000	0100	0200	0300	0400	0500	0600	0700	0800	0900	1000	1100	1200	1300	1400	1500	1600	1700	1800	1900	2000	2100	2200	2300	
205	112	97	118	162	357	612	703	760	680	661	813	773	868	756	1446	1813	2168	1442	778	546	387	303	243	
92	26	30	12	44	46	144	164	209	175	145	187	206	193	199	337	398	536	465	227	155	97	107	64	30
52	38	26	36	26	82	145	184	223	180	193	198	183	242	235	348	426	559	388	172	166	92	80	73	28
34	20	20	34	37	108	158	154	169	165	174	190	203	231	219	348	473	550	330	201	118	102	72	54	28
27	28	21	36	55	121	165	201	159	160	149	238	181	202	103	413	516	523	259	178	107	96	44	52	21

AM Peak 1115 - 1215 (832), AM PHF=0.87 PM Peak 1700 - 1800 (2168), PM PHF=0.97

**Wednesday, January 09, 2013=17055, 15 minute drops**

0000	0100	0200	0300	0400	0500	0600	0700	0800	0900	1000	1100	1200	1300	1400	1500	1600	1700	1800	1900	2000	2100	2200	2300	
107	136	93	100	166	430	558	832	730	695	694	860	743	808	969	1371	1790	2230	1386	678	551	466	369	293	
30	41	33	22	42	53	141	227	172	165	179	208	146	190	236	297	417	602	416	151	155	126	102	79	49
28	31	30	30	33	95	93	216	208	184	157	215	209	228	232	321	436	527	421	185	147	103	113	66	47
28	37	18	30	51	136	216	192	176	172	180	215	201	179	262	339	460	553	304	193	125	137	63	77	32
21	27	12	18	40	146	108	197	174	174	178	222	187	211	239	414	477	548	245	149	124	100	91	71	38

AM Peak 1100 - 1200 (860), AM PHF=0.97 PM Peak 1700 - 1800 (2230), PM PHF=0.93

**Thursday, January 10, 2013=17019, 15 minute drops**

0000	0100	0200	0300	0400	0500	0600	0700	0800	0900	1000	1100	1200	1300	1400	1500	1600	1700	1800	1900	2000	2100	2200	2300	
166	107	110	111	182	324	644	764	559	763	687	759	850	773	1006	1376	1815	2136	1451	769	595	418	388	266	
49	40	34	24	35	47	158	177	150	278	135	178	186	185	238	287	427	530	386	257	144	97	97	76	49
47	26	27	20	42	71	161	200	175	139	175	129	253	138	262	333	443	574	431	213	180	139	110	62	55
32	30	22	29	43	107	110	198	165	166	191	241	220	245	240	365	446	562	360	162	125	84	90	74	49
38	11	27	38	62	99	215	189	69	180	186	211	191	205	266	391	499	470	274	137	146	98	91	54	23

AM Peak 1130 - 1230 (891), AM PHF=0.88 PM Peak 1645 - 1745 (2165), PM PHF=0.94

# Southern Traffic Services, Inc.

## Event Counts

**Port Sutton Road west of US 41**

**Eastbound**

**Datasets:**

**Site:** [104] I5048  
**Input A:** 2 - East bound, A hit first. - Added to totals. (1)  
**Input B:** 0 - Unused or unknown. - Excluded from totals. (0)  
**Survey Duration:** 12:01 Monday, January 07, 2013 => 10:17 Friday, January 18, 2013  
**File:** G:\DATA\2013\Private\13015\diego\Data 1-7-13\UM104 EB.eco (Plus)  
**Identifier:** Q339EN1P MC56-L5 [MC55] (c)Microcom 19Oct04  
**Algorithm:** Event Count  
**Data type:** Axle sensors - Paired (Class, Speed, Count)

**Profile:**

**Filter time:** 0:00 Tuesday, January 08, 2013 => 0:00 Friday, January 11, 2013  
**Name:** Factory default profile  
**Scheme:** Count events divided by two.  
**Units:** Non metric (ft, mi, ft/s, mph, lb, ton)  
**In profile:** Events = 2417

**Tuesday, January 08, 2013=752, 15 minute drops**

0000	0100	0200	0300	0400	0500	0600	0700	0800	0900	1000	1100	1200	1300	1400	1500	1600	1700	1800	1900	2000	2100	2200	2300	
1	0	4	4	5	14	24	32	50	42	52	79	60	63	63	110	57	21	26	22	5	9	4	5	
0	0	0	0	1	4	0	6	16	9	11	17	23	18	14	36	15	14	5	8	1	0	0	1	0
0	0	0	1	0	1	4	10	11	10	11	19	8	13	10	22	27	4	1	4	0	1	0	2	1
0	0	2	0	0	2	6	10	10	9	17	30	9	18	22	33	6	1	3	4	2	6	0	1	0
1	0	2	3	4	7	14	6	13	14	13	13	20	14	17	19	9	2	17	6	2	2	4	1	0

AM Peak 1115 - 1215 (85), AM PHF=0.71 PM Peak 1500 - 1600 (110), PM PHF=0.76

**Wednesday, January 09, 2013=807, 15 minute drops**

0000	0100	0200	0300	0400	0500	0600	0700	0800	0900	1000	1100	1200	1300	1400	1500	1600	1700	1800	1900	2000	2100	2200	2300	
1	2	0	6	3	12	69	28	47	61	48	64	52	60	67	106	78	37	26	16	6	6	7	5	
0	2	0	1	0	8	12	7	13	13	10	19	8	11	16	43	29	15	3	7	2	1	2	2	1
1	0	0	0	1	1	10	6	7	19	11	13	18	18	13	22	26	9	3	4	0	1	2	0	1
0	0	0	2	0	2	17	13	16	10	9	14	9	14	22	27	17	7	5	3	3	3	1	2	1
0	0	0	3	2	1	30	2	11	19	18	18	17	17	16	14	6	6	15	2	1	1	2	1	0

AM Peak 0600 - 0700 (69), AM PHF=0.57 PM Peak 1445 - 1545 (108), PM PHF=0.63

**Thursday, January 10, 2013=858, 15 minute drops**

0000	0100	0200	0300	0400	0500	0600	0700	0800	0900	1000	1100	1200	1300	1400	1500	1600	1700	1800	1900	2000	2100	2200	2300	
3	2	3	4	5	15	46	36	52	41	53	68	70	58	88	145	65	28	23	28	10	8	3	4	
1	1	1	0	0	5	2	12	11	10	10	20	18	15	25	43	26	14	6	23	2	0	0	2	2
1	0	1	1	1	5	9	5	14	8	14	14	20	17	23	46	19	6	3	3	6	4	1	0	0
1	1	0	1	2	4	9	11	14	12	14	16	12	13	24	32	10	2	4	2	1	3	1	1	0
0	0	1	2	2	1	26	8	13	11	15	18	20	13	16	24	10	6	10	0	1	1	1	1	0

AM Peak 1130 - 1230 (72), AM PHF=0.90 PM Peak 1500 - 1600 (145), PM PHF=0.79



# Southern Traffic Services, Inc.

## Event Counts

**Port Sutton Road west of US 41**

**Westbound**

**Datasets:**

**Site:** [104] !C7018  
**Input A:** 4 - West bound, A hit first. - Added to totals. (1)  
**Input B:** 0 - Unused or unknown. - Excluded from totals. (0)  
**Survey Duration:** 12:01 Monday, January 07, 2013 => 12:20 Friday, January 11, 2013  
**File:** G:\DATA\2013\Private\13015\diego\Data 1-7-13\UM104wb.eco (Plus)  
**Identifier:** U760QBTN MC56-L5 [MC55] (c)Microcom 19Oct04  
**Algorithm:** Event Count  
**Data type:** Axle sensors - Paired (Class, Speed, Count)

**Profile:**

**Filter time:** 0:00 Tuesday, January 08, 2013 => 0:00 Friday, January 11, 2013  
**Name:** Factory default profile  
**Scheme:** Count events divided by two.  
**Units:** Non metric (ft, mi, ft/s, mph, lb, ton)  
**In profile:** Events = 2445

**Tuesday, January 08, 2013=793, 15 minute drops**

0000	0100	0200	0300	0400	0500	0600	0700	0800	0900	1000	1100	1200	1300	1400	1500	1600	1700	1800	1900	2000	2100	2200	2300	
1	1	12	5	20	23	112	78	49	55	78	63	76	57	49	46	22	7	18	8	4	4	4	1	
0	0	0	0	5	1	16	24	14	9	16	20	20	16	17	13	3	2	4	5	1	0	0	1	0
0	0	2	1	1	4	29	11	15	8	20	17	12	13	13	7	7	1	7	0	2	2	1	0	0
0	0	4	1	7	5	23	16	8	24	17	15	25	14	11	20	9	1	4	0	1	2	2	0	1
1	1	6	3	7	13	44	27	12	14	25	11	19	14	8	6	3	3	3	3	0	0	1	0	0

AM Peak 0615 - 0715 (120), AM PHF=0.68 PM Peak 1200 - 1300 (76), PM PHF=0.76

**Wednesday, January 09, 2013=784, 15 minute drops**

0000	0100	0200	0300	0400	0500	0600	0700	0800	0900	1000	1100	1200	1300	1400	1500	1600	1700	1800	1900	2000	2100	2200	2300	
1	3	7	11	17	30	105	64	53	50	54	65	71	46	71	48	33	7	18	9	4	3	10	4	
0	2	0	5	2	1	21	28	14	10	14	22	14	8	20	9	13	2	3	4	1	1	2	1	0
0	0	1	2	1	6	26	12	9	14	11	9	18	14	11	11	7	3	5	3	2	1	3	2	0
1	1	3	2	6	10	29	13	12	13	14	23	23	6	21	16	4	0	4	2	0	0	5	1	0
0	0	3	2	8	13	29	11	18	13	15	11	16	18	19	12	9	2	6	0	1	1	0	0	1

AM Peak 0615 - 0715 (112), AM PHF=0.97 PM Peak 1200 - 1300 (71), PM PHF=0.77

**Thursday, January 10, 2013=868, 15 minute drops**

0000	0100	0200	0300	0400	0500	0600	0700	0800	0900	1000	1100	1200	1300	1400	1500	1600	1700	1800	1900	2000	2100	2200	2300	
1	2	12	6	15	30	140	42	54	67	64	79	79	80	56	64	23	9	23	4	3	6	6	3	
0	1	2	0	3	3	29	17	14	13	6	14	22	24	20	23	3	3	5	2	1	2	0	1	1
0	0	2	0	1	4	29	8	11	9	20	16	28	16	11	17	8	1	8	0	0	3	2	0	0
0	0	5	2	3	8	34	8	21	15	22	34	16	23	13	12	4	1	5	2	1	0	3	1	3
1	1	3	4	8	15	48	9	8	30	16	15	13	17	12	12	8	4	5	0	1	1	1	1	0

AM Peak 0600 - 0700 (140), AM PHF=0.73 PM Peak 1215 - 1315 (81), PM PHF=0.72



# Southern Traffic Services, Inc.

2911 Westfield Rd  
Gulf Breeze, FL 32563  
1-800-786-3374

*Traffic is our only business!*

US 41 @ Hartford St  
Tampa, FL

File Name : 13015-11 US 41 @ Hartford St  
Site Code : 13015-11  
Start Date : 1/8/2013  
Page No : 1

Groups Printed- Automobiles - Trucks - Buses

Start Time	US 41 Southbound				HARTFORD ST Westbound				US 41 Northbound				HARTFORD ST Eastbound				Int. Total
	Left	Thru	Right	U-Turns	Left	Thru	Right	U-Turns	Left	Thru	Right	U-Turns	Left	Thru	Right	U-Turns	
07:00 AM	7	184	1	0	0	0	7	0	1	587	5	0	0	0	1	0	793
07:15 AM	7	160	6	0	1	0	7	0	2	558	3	0	0	0	0	0	744
07:30 AM	8	148	4	0	4	0	10	0	1	519	8	0	1	0	1	0	704
07:45 AM	15	171	1	0	3	0	16	0	4	498	1	1	2	0	0	0	712
<b>Total</b>	<b>37</b>	<b>663</b>	<b>12</b>	<b>0</b>	<b>8</b>	<b>0</b>	<b>40</b>	<b>0</b>	<b>8</b>	<b>2162</b>	<b>17</b>	<b>1</b>	<b>3</b>	<b>0</b>	<b>2</b>	<b>0</b>	<b>2953</b>
08:00 AM	2	192	1	0	3	0	11	0	0	433	5	0	0	0	0	0	647
08:15 AM	7	184	3	0	2	0	7	0	1	349	2	0	0	0	0	0	555
08:30 AM	13	125	3	0	4	0	1	2	1	356	3	0	1	0	0	0	509
08:45 AM	2	132	6	0	3	0	2	0	1	269	5	0	2	0	2	0	424
<b>Total</b>	<b>24</b>	<b>633</b>	<b>13</b>	<b>0</b>	<b>12</b>	<b>0</b>	<b>21</b>	<b>2</b>	<b>3</b>	<b>1407</b>	<b>15</b>	<b>0</b>	<b>3</b>	<b>0</b>	<b>2</b>	<b>0</b>	<b>2135</b>
<b>**BREAK**</b>																	
04:00 PM	4	359	2	0	3	0	12	0	0	193	5	0	8	2	1	0	589
04:15 PM	6	446	0	0	3	0	9	0	2	205	4	0	4	0	1	0	680
04:30 PM	11	444	1	0	1	0	5	0	0	188	3	0	3	0	2	0	658
04:45 PM	5	501	0	0	1	0	9	0	3	176	7	0	0	0	1	0	703
<b>Total</b>	<b>26</b>	<b>1750</b>	<b>3</b>	<b>0</b>	<b>8</b>	<b>0</b>	<b>35</b>	<b>0</b>	<b>5</b>	<b>762</b>	<b>19</b>	<b>0</b>	<b>15</b>	<b>2</b>	<b>5</b>	<b>0</b>	<b>2630</b>
05:00 PM	11	552	0	0	5	0	14	0	0	208	2	2	1	0	1	0	796
05:15 PM	10	551	1	0	6	0	10	0	0	182	3	0	4	0	1	0	768
05:30 PM	12	514	1	0	3	0	10	0	0	193	3	0	2	0	1	0	739
05:45 PM	6	533	2	0	2	0	10	0	1	175	1	0	0	0	0	0	730
<b>Total</b>	<b>39</b>	<b>2150</b>	<b>4</b>	<b>0</b>	<b>16</b>	<b>0</b>	<b>44</b>	<b>0</b>	<b>1</b>	<b>758</b>	<b>9</b>	<b>2</b>	<b>7</b>	<b>0</b>	<b>3</b>	<b>0</b>	<b>3033</b>
<b>Grand Total</b>	<b>126</b>	<b>5196</b>	<b>32</b>	<b>0</b>	<b>44</b>	<b>0</b>	<b>140</b>	<b>2</b>	<b>17</b>	<b>5089</b>	<b>60</b>	<b>3</b>	<b>28</b>	<b>2</b>	<b>12</b>	<b>0</b>	<b>10751</b>
Apprch %	2.4	97	0.6	0	23.7	0	75.3	1.1	0.3	98.5	1.2	0.1	66.7	4.8	28.6	0	
Total %	1.2	48.3	0.3	0	0.4	0	1.3	0	0.2	47.3	0.6	0	0.3	0	0.1	0	
Automobiles	103	4844	29	0	35	0	116	2	15	4767	52	3	25	2	10	0	10003
% Automobiles	81.7	93.2	90.6	0	79.5	0	82.9	100	88.2	93.7	86.7	100	89.3	100	83.3	0	93
Trucks	23	346	3	0	9	0	24	0	2	320	7	0	3	0	2	0	739
% Trucks	18.3	6.7	9.4	0	20.5	0	17.1	0	11.8	6.3	11.7	0	10.7	0	16.7	0	6.9
Buses	0	6	0	0	0	0	0	0	0	2	1	0	0	0	0	0	9
% Buses	0	0.1	0	0	0	0	0	0	0	0	1.7	0	0	0	0	0	0.1



# Southern Traffic Services, Inc.

2911 Westfield Rd  
 Gulf Breeze, FL 32563  
 1-800-786-3374

*Traffic is our only business!*

US 41 @ Hartford St  
 Tampa, FL

File Name : 13015-11 US 41 @ Hartford St  
 Site Code : 13015-11  
 Start Date : 1/8/2013  
 Page No : 2

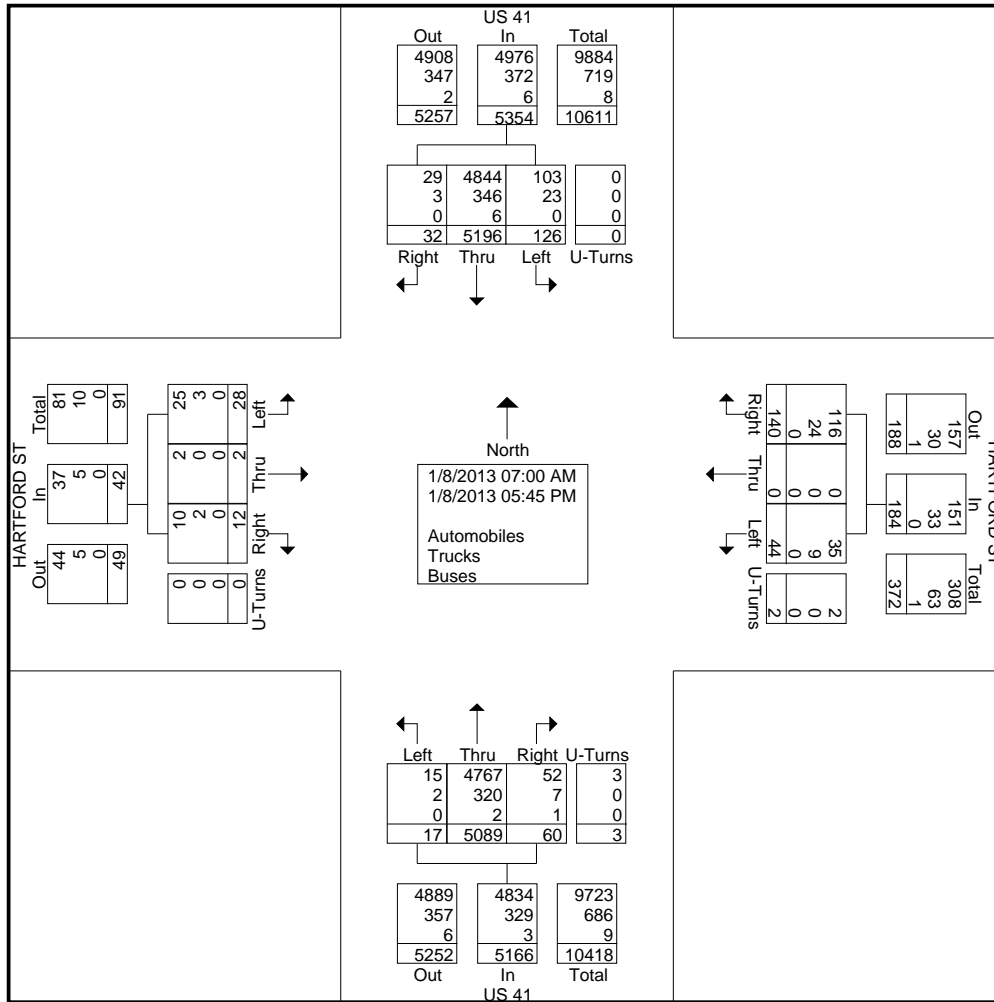



# Southern Traffic Services, Inc.

2911 Westfield Rd  
Gulf Breeze, FL 32563  
1-800-786-3374

*Traffic is our only business!*

US 41 @ Hartford St  
Tampa, FL

File Name : 13015-11 US 41 @ Hartford St  
Site Code : 13015-11  
Start Date : 1/8/2013  
Page No : 3

Start Time	US 41 Southbound				HARTFORD ST Westbound				US 41 Northbound				HARTFORD ST Eastbound				Int. Total				
	Thru	Right	U-Turns	App. Total	Left	Thru	Right	U-Turns	App. Total	Left	Thru	Right	U-Turns	App. Total	Left	Thru		Right	U-Turns	App. Total	
Peak Hour Analysis From 07:00 AM to 11:45 AM - Peak 1 of 1																					
Peak Hour for Entire Intersection Begins at 07:00 AM																					
07:00 AM	7	184	1	0	192	0	0	7	0	7	1	587	5	0	593	0	0	1	0	1	793
07:15 AM	7	160	6	0	173	1	0	7	0	8	2	558	3	0	563	0	0	0	0	0	744
07:30 AM	8	148	4	0	160	4	0	10	0	14	1	519	8	0	528	1	0	1	0	2	704
07:45 AM	15	171	1	0	187	3	0	16	0	19	4	498	1	1	504	2	0	0	0	2	712
Total Volume	37	663	12	0	712	8	0	40	0	48	8	2162	17	1	2188	3	0	2	0	5	2953
% App. Total	5.2	93.1	1.7	0		16.7	0	83.3	0		0.4	98.8	0.8	0		60	0	40	0		
PHF	.617	.901	.500	.000	.927	.500	.000	.625	.000	.632	.500	.921	.531	.250	.922	.375	.000	.500	.000	.625	.931
Automobiles	34	553	12	0	599	5	0	30	0	35	7	2079	14	1	2101	3	0	2	0	5	2740
% Automobiles	91.9	83.4	100	0	84.1	62.5	0	75.0	0	72.9	87.5	96.2	82.4	100	96.0	100	0	100	0	100	92.8
Trucks	3	107	0	0	110	3	0	10	0	13	1	82	2	0	85	0	0	0	0	0	208
% Trucks	8.1	16.1	0	0	15.4	37.5	0	25.0	0	27.1	12.5	3.8	11.8	0	3.9	0	0	0	0	0	7.0
Buses	0	3	0	0	3	0	0	0	0	0	0	1	1	0	2	0	0	0	0	0	5
% Buses	0	0.5	0	0	0.4	0	0	0	0	0	0	0.0	5.9	0	0.1	0	0	0	0	0	0.2

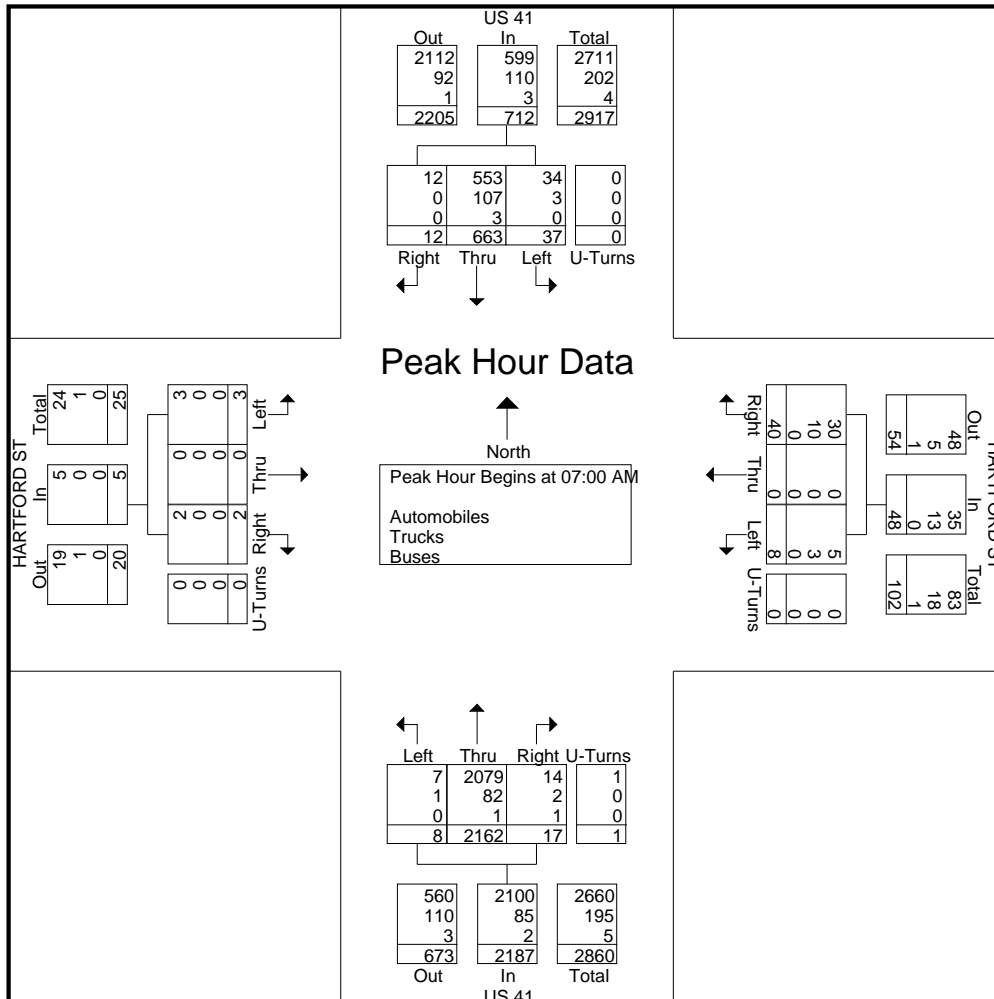



# Southern Traffic Services, Inc.

2911 Westfield Rd  
Gulf Breeze, FL 32563  
1-800-786-3374

*Traffic is our only business!*

US 41 @ Hartford St  
Tampa, FL

File Name : 13015-11 US 41 @ Hartford St  
Site Code : 13015-11  
Start Date : 1/8/2013  
Page No : 4

Start Time	US 41 Southbound					HARTFORD ST Westbound					US 41 Northbound					HARTFORD ST Eastbound					Int. Total
	Left	Thru	Right	U-Turns	App. Total	Left	Thru	Right	U-Turns	App. Total	Left	Thru	Right	U-Turns	App. Total	Left	Thru	Right	U-Turns	App. Total	

Peak Hour Analysis From 12:00 PM to 05:45 PM - Peak 1 of 1

Peak Hour for Entire Intersection Begins at 05:00 PM

05:00 PM	11	552	0	0	563	5	0	14	0	19	0	208	2	2	212	1	0	1	0	2	796
05:15 PM	10	551	1	0	562	6	0	10	0	16	0	182	3	0	185	4	0	1	0	5	768
05:30 PM	12	514	1	0	527	3	0	10	0	13	0	193	3	0	196	2	0	1	0	3	739
05:45 PM	6	533	2	0	541	2	0	10	0	12	1	175	1	0	177	0	0	0	0	0	730
Total Volume	39	2150	4	0	2193	16	0	44	0	60	1	758	9	2	770	7	0	3	0	10	3033
% App. Total	1.8	98	0.2	0		26.7	0	73.3	0		0.1	98.4	1.2	0.3		70	0	30	0		
PHF	.813	.974	.500	.000	.974	.667	.000	.786	.000	.789	.250	.911	.750	.250	.908	.438	.000	.750	.000	.500	.953
Automobiles	29	2103	3	0	2135	15	0	37	0	52	0	716	8	2	726	6	0	3	0	9	2922
% Automobiles	74.4	97.8	75.0	0	97.4	93.8	0	84.1	0	86.7	0	94.5	88.9	100	94.3	85.7	0	100	0	90.0	96.3
Trucks	10	46	1	0	57	1	0	7	0	8	1	41	1	0	43	1	0	0	0	1	109
% Trucks	25.6	2.1	25.0	0	2.6	6.3	0	15.9	0	13.3	100	5.4	11.1	0	5.6	14.3	0	0	0	10.0	3.6
Buses	0	1	0	0	1	0	0	0	0	0	0	1	0	0	1	0	0	0	0	0	2
% Buses	0	0.0	0	0	0.0	0	0	0	0	0	0	0.1	0	0	0.1	0	0	0	0	0	0.1

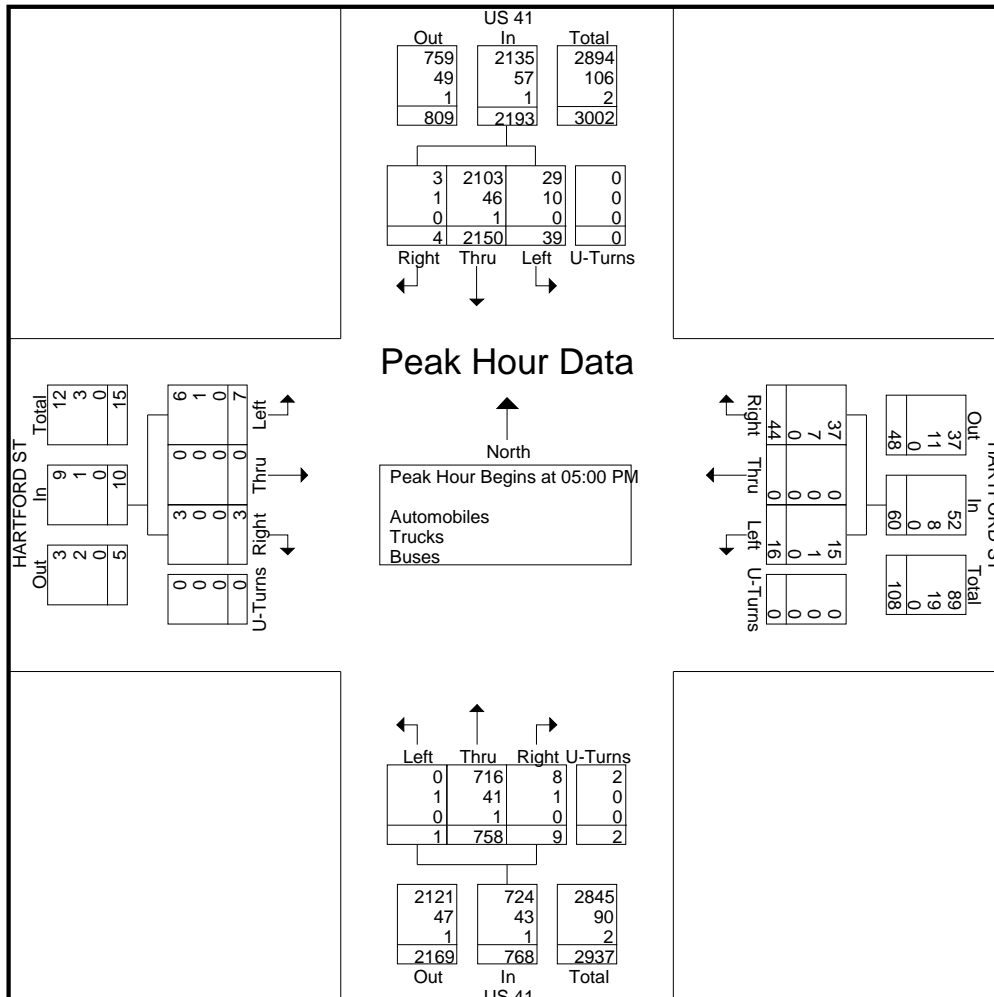



# Southern Traffic Services, Inc.

2911 Westfield Rd  
Gulf Breeze, FL 32563  
1-800-786-3374

*Traffic is our only business!*

US 41 @ Hartford St  
Tampa, FL

File Name : 13015-11 US 41 @ Hartford St  
Site Code : 13015-11  
Start Date : 1/8/2013  
Page No : 1

Groups Printed- Automobiles

Start Time	US 41 Southbound				HARTFORD ST Westbound				US 41 Northbound				HARTFORD ST Eastbound				Int. Total
	Left	Thru	Right	U-Turns	Left	Thru	Right	U-Turns	Left	Thru	Right	U-Turns	Left	Thru	Right	U-Turns	
07:00 AM	7	155	1	0	0	0	6	0	1	562	4	0	0	0	1	0	737
07:15 AM	5	133	6	0	1	0	4	0	2	543	3	0	0	0	0	0	697
07:30 AM	7	122	4	0	2	0	8	0	1	496	6	0	1	0	1	0	648
07:45 AM	15	143	1	0	2	0	12	0	3	478	1	1	2	0	0	0	658
Total	34	553	12	0	5	0	30	0	7	2079	14	1	3	0	2	0	2740
08:00 AM	2	152	1	0	2	0	9	0	0	399	5	0	0	0	0	0	570
08:15 AM	7	157	3	0	2	0	5	0	1	312	2	0	0	0	0	0	489
08:30 AM	13	104	3	0	2	0	1	2	1	331	3	0	1	0	0	0	461
08:45 AM	2	101	4	0	1	0	2	0	1	238	4	0	2	0	0	0	355
Total	24	514	11	0	7	0	17	2	3	1280	14	0	3	0	0	0	1875
<b>**BREAK**</b>																	
04:00 PM	3	336	2	0	3	0	10	0	0	170	3	0	7	2	1	0	537
04:15 PM	3	423	0	0	3	0	8	0	2	183	4	0	3	0	1	0	630
04:30 PM	7	433	1	0	1	0	5	0	0	173	2	0	3	0	2	0	627
04:45 PM	3	482	0	0	1	0	9	0	3	166	7	0	0	0	1	0	672
Total	16	1674	3	0	8	0	32	0	5	692	16	0	13	2	5	0	2466
05:00 PM	8	539	0	0	5	0	14	0	0	189	2	2	1	0	1	0	761
05:15 PM	7	539	0	0	5	0	9	0	0	173	2	0	3	0	1	0	739
05:30 PM	9	504	1	0	3	0	8	0	0	187	3	0	2	0	1	0	718
05:45 PM	5	521	2	0	2	0	6	0	0	167	1	0	0	0	0	0	704
Total	29	2103	3	0	15	0	37	0	0	716	8	2	6	0	3	0	2922
Grand Total	103	4844	29	0	35	0	116	2	15	4767	52	3	25	2	10	0	10003
Apprch %	2.1	97.3	0.6	0	22.9	0	75.8	1.3	0.3	98.6	1.1	0.1	67.6	5.4	27	0	
Total %	1	48.4	0.3	0	0.3	0	1.2	0	0.1	47.7	0.5	0	0.2	0	0.1	0	



# Southern Traffic Services, Inc.

2911 Westfield Rd  
Gulf Breeze, FL 32563  
1-800-786-3374

*Traffic is our only business!*

US 41 @ Hartford St  
Tampa, FL

File Name : 13015-11 US 41 @ Hartford St  
Site Code : 13015-11  
Start Date : 1/8/2013  
Page No : 2

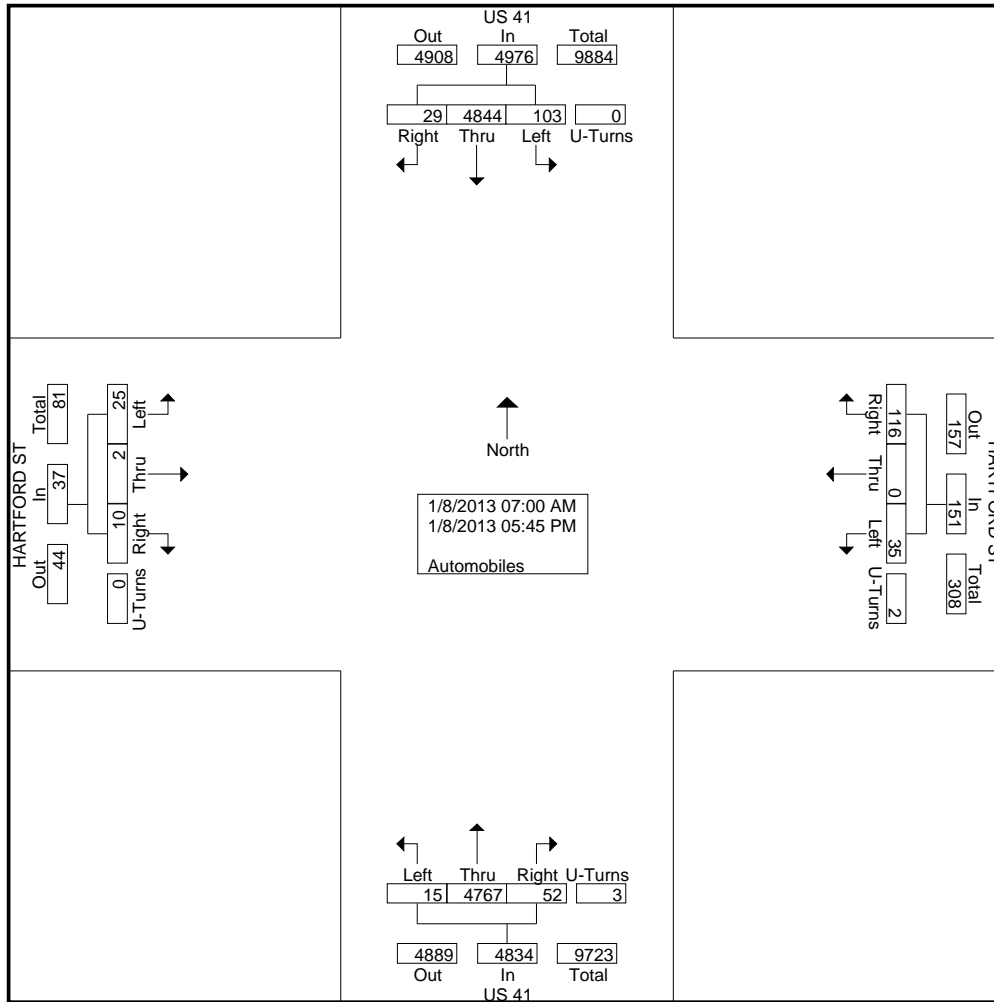



# Southern Traffic Services, Inc.

2911 Westfield Rd  
 Gulf Breeze, FL 32563  
 1-800-786-3374

*Traffic is our only business!*

US 41 @ Hartford St  
 Tampa, FL

File Name : 13015-11 US 41 @ Hartford St  
 Site Code : 13015-11  
 Start Date : 1/8/2013  
 Page No : 3

Start Time	US 41 Southbound				HARTFORD ST Westbound				US 41 Northbound				HARTFORD ST Eastbound				Int. Total				
	Thru	Right	U-Turns	App. Total	Left	Thru	Right	U-Turns	App. Total	Left	Thru	Right	U-Turns	App. Total	Left	Thru		Right	U-Turns	App. Total	
Peak Hour Analysis From 07:00 AM to 11:45 AM - Peak 1 of 1																					
Peak Hour for Entire Intersection Begins at 07:00 AM																					
07:00 AM	7	155	1	0	163	0	0	6	0	6	1	562	4	0	567	0	0	1	0	1	737
07:15 AM	5	133	6	0	144	1	0	4	0	5	2	543	3	0	548	0	0	0	0	0	697
07:30 AM	7	122	4	0	133	2	0	8	0	10	1	496	6	0	503	1	0	1	0	2	648
07:45 AM	15	143	1	0	159	2	0	12	0	14	3	478	1	1	483	2	0	0	0	2	658
Total Volume	34	553	12	0	599	5	0	30	0	35	7	2079	14	1	2101	3	0	2	0	5	2740
% App. Total	5.7	92.3	2	0		14.3	0	85.7	0		0.3	99	0.7	0		60	0	40	0		
PHF	.567	.892	.500	.000	.919	.625	.000	.625	.000	.625	.583	.925	.583	.250	.926	.375	.000	.500	.000	.625	.929

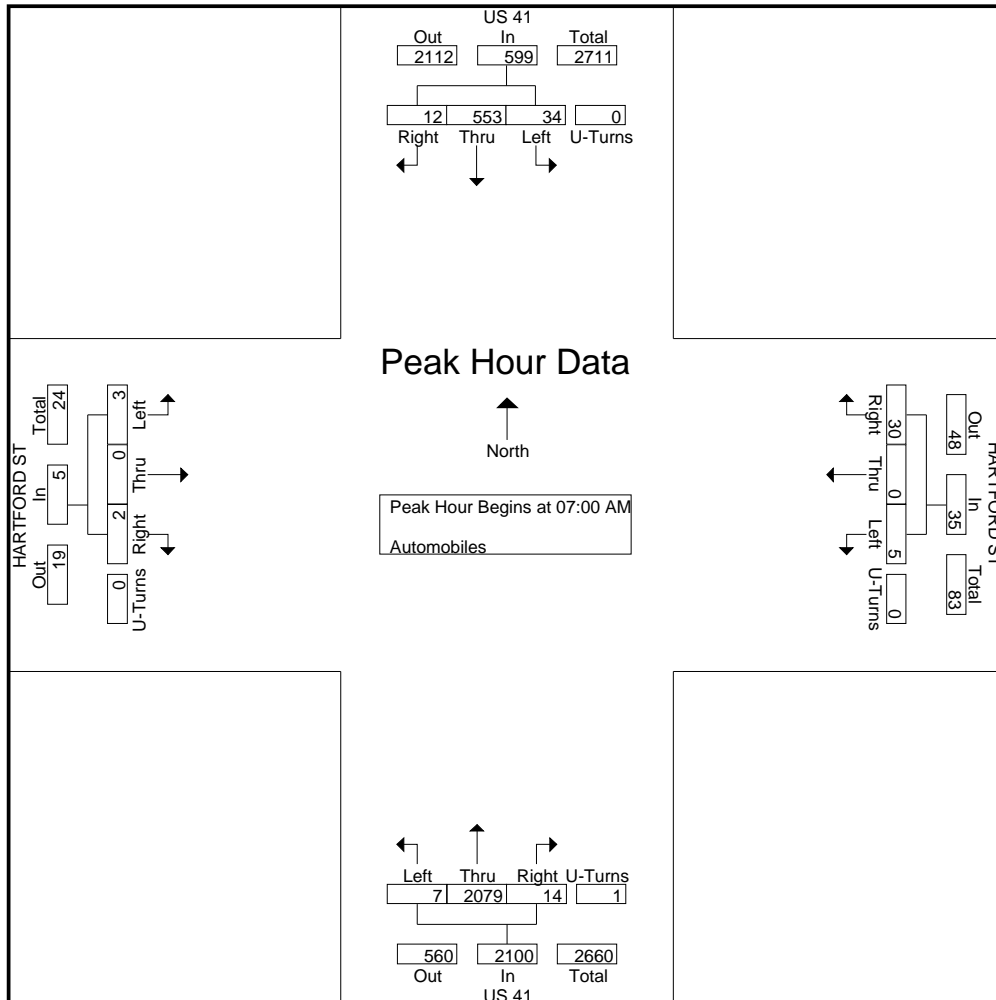





# Southern Traffic Services, Inc.

2911 Westfield Rd  
Gulf Breeze, FL 32563  
1-800-786-3374

*Traffic is our only business!*

US 41 @ Hartford St  
Tampa, FL

File Name : 13015-11 US 41 @ Hartford St  
Site Code : 13015-11  
Start Date : 1/8/2013  
Page No : 4

Start Time	US 41 Southbound					HARTFORD ST Westbound					US 41 Northbound					HARTFORD ST Eastbound					Int. Total
	Left	Thru	Right	U-Turns	App. Total	Left	Thru	Right	U-Turns	App. Total	Left	Thru	Right	U-Turns	App. Total	Left	Thru	Right	U-Turns	App. Total	
Peak Hour Analysis From 12:00 PM to 05:45 PM - Peak 1 of 1																					
Peak Hour for Entire Intersection Begins at 05:00 PM																					
05:00 PM	8	539	0	0	547	5	0	14	0	19	0	189	2	2	193	1	0	1	0	2	761
05:15 PM	7	539	0	0	546	5	0	9	0	14	0	173	2	0	175	3	0	1	0	4	739
05:30 PM	9	504	1	0	514	3	0	8	0	11	0	187	3	0	190	2	0	1	0	3	718
05:45 PM	5	521	2	0	528	2	0	6	0	8	0	167	1	0	168	0	0	0	0	0	704
Total Volume	29	2103	3	0	2135	15	0	37	0	52	0	716	8	2	726	6	0	3	0	9	2922
% App. Total	1.4	98.5	0.1	0		28.8	0	71.2	0		0	98.6	1.1	0.3		66.7	0	33.3	0		
PHF	.806	.975	.375	.000	.976	.750	.000	.661	.000	.684	.000	.947	.667	.250	.940	.500	.000	.750	.000	.563	.960

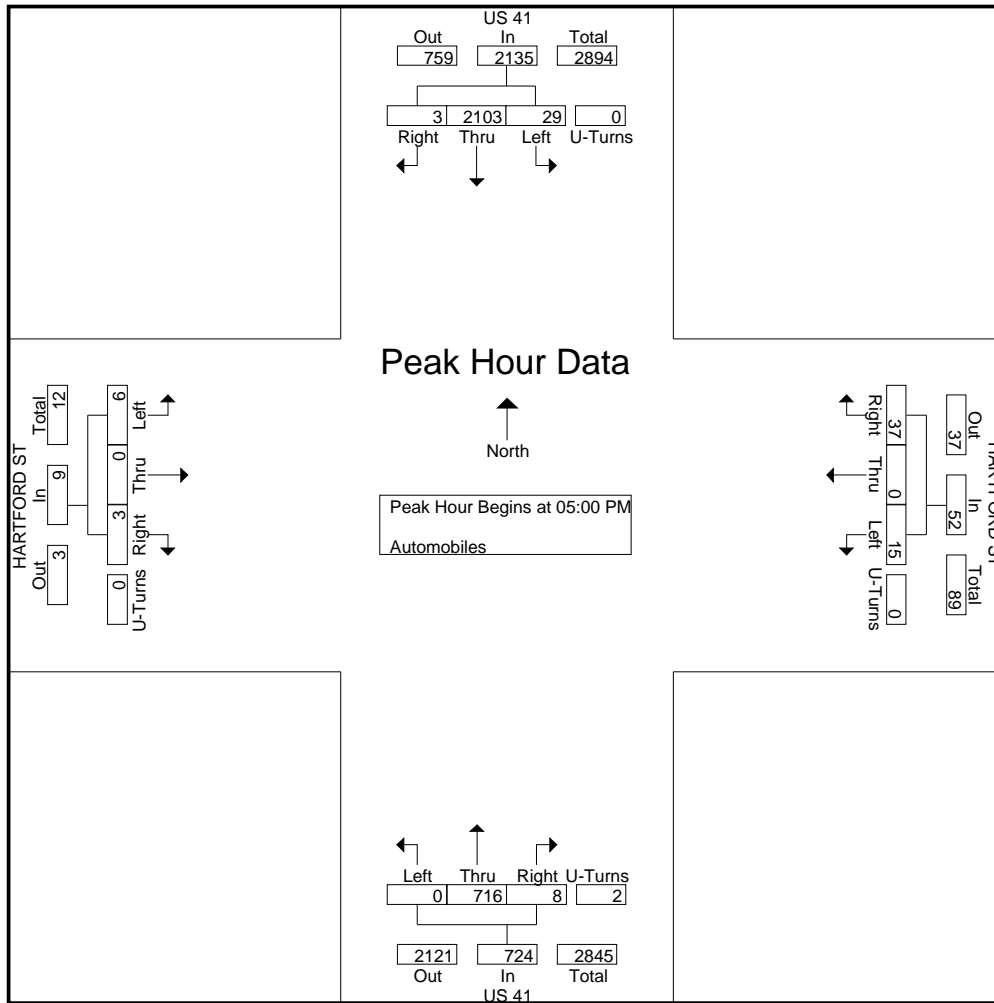



# Southern Traffic Services, Inc.

2911 Westfield Rd  
Gulf Breeze, FL 32563  
1-800-786-3374

*Traffic is our only business!*

US 41 @ Hartford St  
Tampa, FL

File Name : 13015-11 US 41 @ Hartford St  
Site Code : 13015-11  
Start Date : 1/8/2013  
Page No : 1

Groups Printed- Trucks - Buses

Start Time	US 41 Southbound				HARTFORD ST Westbound				US 41 Northbound				HARTFORD ST Eastbound				Int. Total	
	Left	Thru	Right	U-Turns	Left	Thru	Right	U-Turns	Left	Thru	Right	U-Turns	Left	Thru	Right	U-Turns		
07:00 AM	0	29	0	0	0	0	1	0	0	25	1	0	0	0	0	0	0	56
07:15 AM	2	27	0	0	0	0	3	0	0	15	0	0	0	0	0	0	0	47
07:30 AM	1	26	0	0	2	0	2	0	0	23	2	0	0	0	0	0	0	56
07:45 AM	0	28	0	0	1	0	4	0	1	20	0	0	0	0	0	0	0	54
<b>Total</b>	<b>3</b>	<b>110</b>	<b>0</b>	<b>0</b>	<b>3</b>	<b>0</b>	<b>10</b>	<b>0</b>	<b>1</b>	<b>83</b>	<b>3</b>	<b>0</b>	<b>0</b>	<b>0</b>	<b>0</b>	<b>0</b>	<b>0</b>	<b>213</b>
08:00 AM	0	40	0	0	1	0	2	0	0	34	0	0	0	0	0	0	0	77
08:15 AM	0	27	0	0	0	0	2	0	0	37	0	0	0	0	0	0	0	66
08:30 AM	0	21	0	0	2	0	0	0	0	25	0	0	0	0	0	0	0	48
08:45 AM	0	31	2	0	2	0	0	0	0	31	1	0	0	0	0	2	0	69
<b>Total</b>	<b>0</b>	<b>119</b>	<b>2</b>	<b>0</b>	<b>5</b>	<b>0</b>	<b>4</b>	<b>0</b>	<b>0</b>	<b>127</b>	<b>1</b>	<b>0</b>	<b>0</b>	<b>0</b>	<b>0</b>	<b>2</b>	<b>0</b>	<b>260</b>
<b>**BREAK**</b>																		
04:00 PM	1	23	0	0	0	0	2	0	0	23	2	0	1	0	0	0	0	52
04:15 PM	3	23	0	0	0	0	1	0	0	22	0	0	1	0	0	0	0	50
04:30 PM	4	11	0	0	0	0	0	0	0	15	1	0	0	0	0	0	0	31
04:45 PM	2	19	0	0	0	0	0	0	0	10	0	0	0	0	0	0	0	31
<b>Total</b>	<b>10</b>	<b>76</b>	<b>0</b>	<b>0</b>	<b>0</b>	<b>0</b>	<b>3</b>	<b>0</b>	<b>0</b>	<b>70</b>	<b>3</b>	<b>0</b>	<b>2</b>	<b>0</b>	<b>0</b>	<b>0</b>	<b>0</b>	<b>164</b>
05:00 PM	3	13	0	0	0	0	0	0	0	19	0	0	0	0	0	0	0	35
05:15 PM	3	12	1	0	1	0	1	0	0	9	1	0	1	0	0	0	0	29
05:30 PM	3	10	0	0	0	0	2	0	0	6	0	0	0	0	0	0	0	21
05:45 PM	1	12	0	0	0	0	4	0	1	8	0	0	0	0	0	0	0	26
<b>Total</b>	<b>10</b>	<b>47</b>	<b>1</b>	<b>0</b>	<b>1</b>	<b>0</b>	<b>7</b>	<b>0</b>	<b>1</b>	<b>42</b>	<b>1</b>	<b>0</b>	<b>1</b>	<b>0</b>	<b>0</b>	<b>0</b>	<b>0</b>	<b>111</b>
<b>Grand Total</b>	<b>23</b>	<b>352</b>	<b>3</b>	<b>0</b>	<b>9</b>	<b>0</b>	<b>24</b>	<b>0</b>	<b>2</b>	<b>322</b>	<b>8</b>	<b>0</b>	<b>3</b>	<b>0</b>	<b>2</b>	<b>0</b>	<b>0</b>	<b>748</b>
Apprch %	6.1	93.1	0.8	0	27.3	0	72.7	0	0.6	97	2.4	0	60	0	40	0	0	
Total %	3.1	47.1	0.4	0	1.2	0	3.2	0	0.3	43	1.1	0	0.4	0	0.3	0	0	
Trucks	23	346	3	0	9	0	24	0	2	320	7	0	3	0	2	0	0	739
% Trucks	100	98.3	100	0	100	0	100	0	100	99.4	87.5	0	100	0	100	0	0	98.8
Buses	0	6	0	0	0	0	0	0	0	2	1	0	0	0	0	0	0	9
% Buses	0	1.7	0	0	0	0	0	0	0	0.6	12.5	0	0	0	0	0	0	1.2



# Southern Traffic Services, Inc.

2911 Westfield Rd  
 Gulf Breeze, FL 32563  
 1-800-786-3374

*Traffic is our only business!*

US 41 @ Hartford St  
 Tampa, FL

File Name : 13015-11 US 41 @ Hartford St  
 Site Code : 13015-11  
 Start Date : 1/8/2013  
 Page No : 2

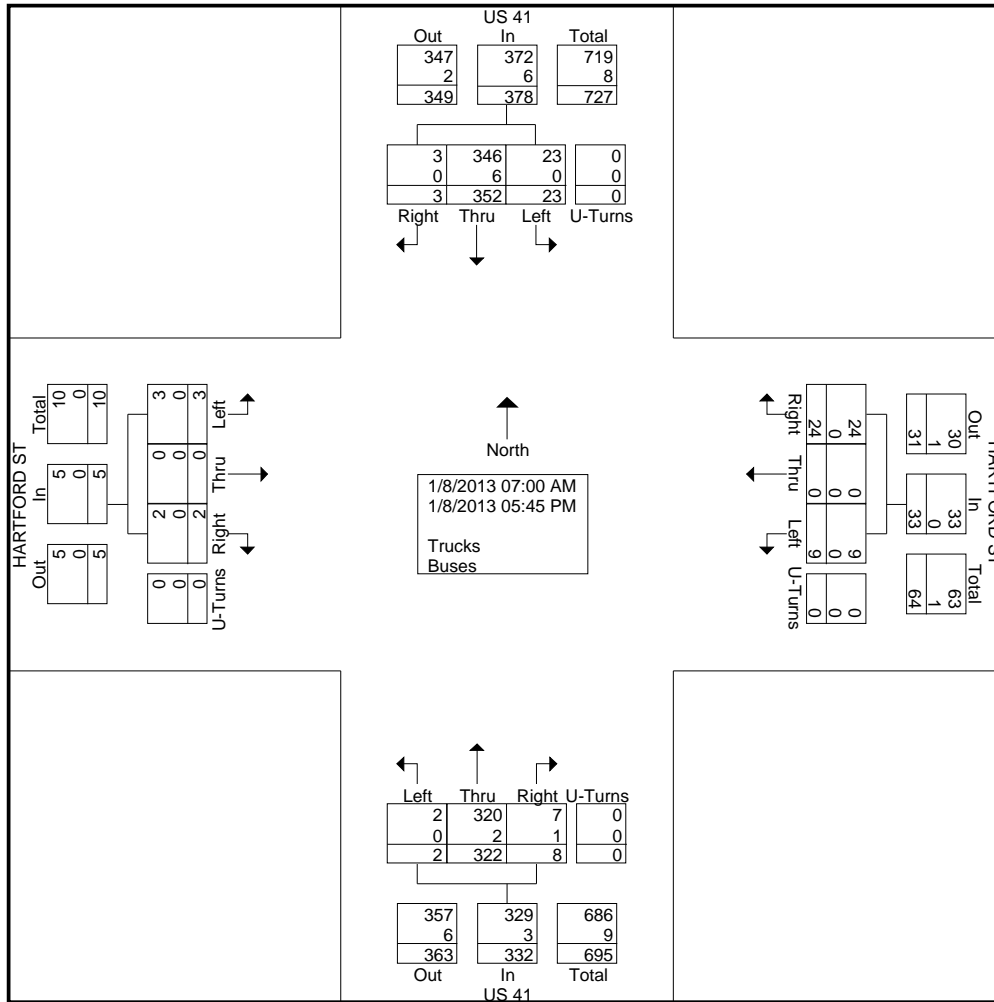



# Southern Traffic Services, Inc.

2911 Westfield Rd  
Gulf Breeze, FL 32563  
1-800-786-3374

*Traffic is our only business!*

US 41 @ Hartford St  
Tampa, FL

File Name : 13015-11 US 41 @ Hartford St  
Site Code : 13015-11  
Start Date : 1/8/2013  
Page No : 3

Start Time	US 41 Southbound				HARTFORD ST Westbound				US 41 Northbound				HARTFORD ST Eastbound				Int. Total				
	Thru	Right	U-Turns	App. Total	Left	Thru	Right	U-Turns	App. Total	Left	Thru	Right	U-Turns	App. Total	Left	Thru		Right	U-Turns	App. Total	
Peak Hour Analysis From 07:00 AM to 11:45 AM - Peak 1 of 1																					
Peak Hour for Entire Intersection Begins at 08:00 AM																					
08:00 AM	0	40	0	40	1	0	2	0	3	0	34	0	0	34	0	0	0	0	0	77	
08:15 AM	0	27	0	27	0	0	2	0	2	0	37	0	0	37	0	0	0	0	0	66	
08:30 AM	0	21	0	21	2	0	0	0	2	0	25	0	0	25	0	0	0	0	0	48	
08:45 AM	0	31	2	33	2	0	0	0	2	0	31	1	0	32	0	0	2	0	2	69	
Total Volume	0	119	2	121	5	0	4	0	9	0	127	1	0	128	0	0	2	0	2	260	
% App. Total	0	98.3	1.7	0	55.6	0	44.4	0	0	0	99.2	0.8	0	0	0	0	100	0	0		
PHF	.000	.744	.250	.000	.756	.625	.000	.500	.000	.750	.000	.858	.250	.000	.865	.000	.000	.250	.000	.250	.844

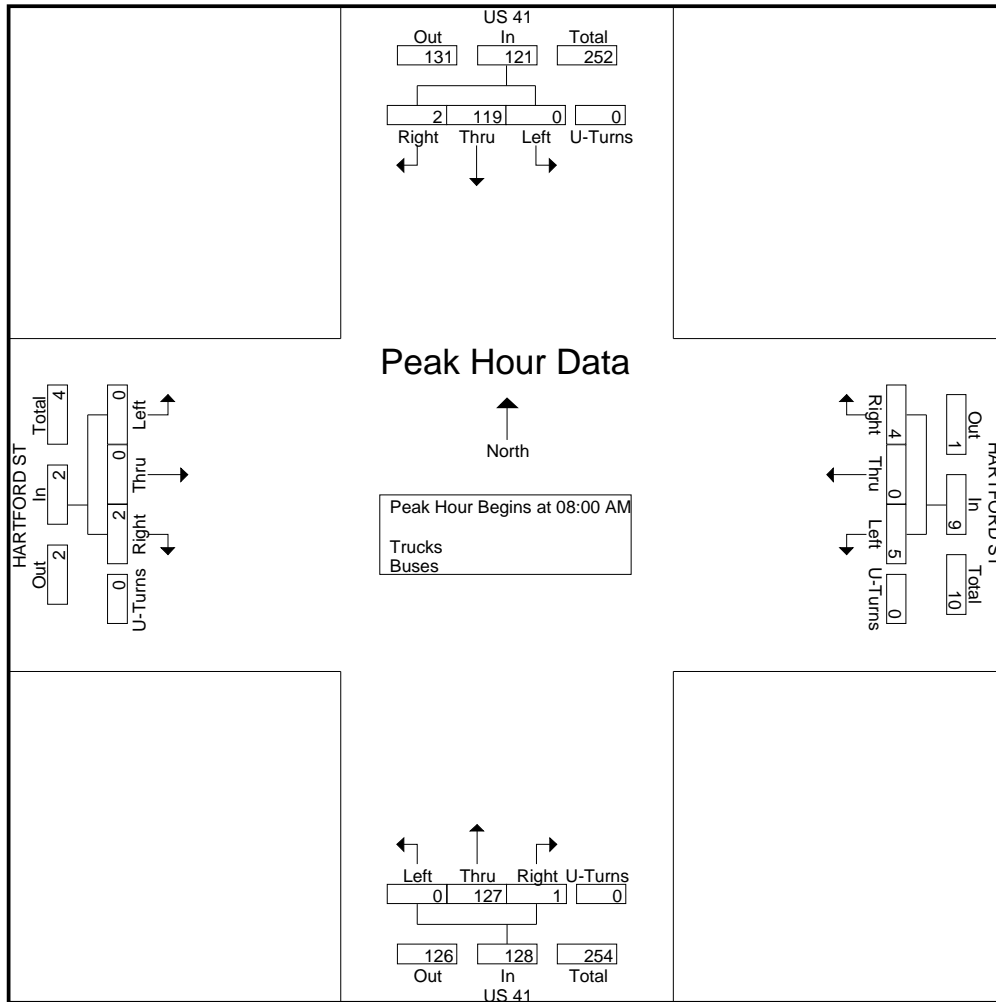



# Southern Traffic Services, Inc.

2911 Westfield Rd  
Gulf Breeze, FL 32563  
1-800-786-3374

*Traffic is our only business!*

US 41 @ Hartford St  
Tampa, FL

File Name : 13015-11 US 41 @ Hartford St  
Site Code : 13015-11  
Start Date : 1/8/2013  
Page No : 4

Start Time	US 41 Southbound					HARTFORD ST Westbound					US 41 Northbound					HARTFORD ST Eastbound					Int. Total
	Left	Thru	Right	U-Turns	App. Total	Left	Thru	Right	U-Turns	App. Total	Left	Thru	Right	U-Turns	App. Total	Left	Thru	Right	U-Turns	App. Total	
Peak Hour Analysis From 12:00 PM to 05:45 PM - Peak 1 of 1																					
Peak Hour for Entire Intersection Begins at 04:00 PM																					
04:00 PM	1	23	0	0	24	0	0	2	0	2	0	23	2	0	25	1	0	0	0	1	52
04:15 PM	3	23	0	0	26	0	0	1	0	1	0	22	0	0	22	1	0	0	0	1	50
04:30 PM	4	11	0	0	15	0	0	0	0	0	0	15	1	0	16	0	0	0	0	0	31
04:45 PM	2	19	0	0	21	0	0	0	0	0	0	10	0	0	10	0	0	0	0	0	31
Total Volume	10	76	0	0	86	0	0	3	0	3	0	70	3	0	73	2	0	0	0	2	164
% App. Total	11.6	88.4	0	0		0	0	100	0		0	95.9	4.1	0		100	0	0	0		
PHF	.625	.826	.000	.000	.827	.000	.000	.375	.000	.375	.000	.761	.375	.000	.730	.500	.000	.000	.000	.500	.788

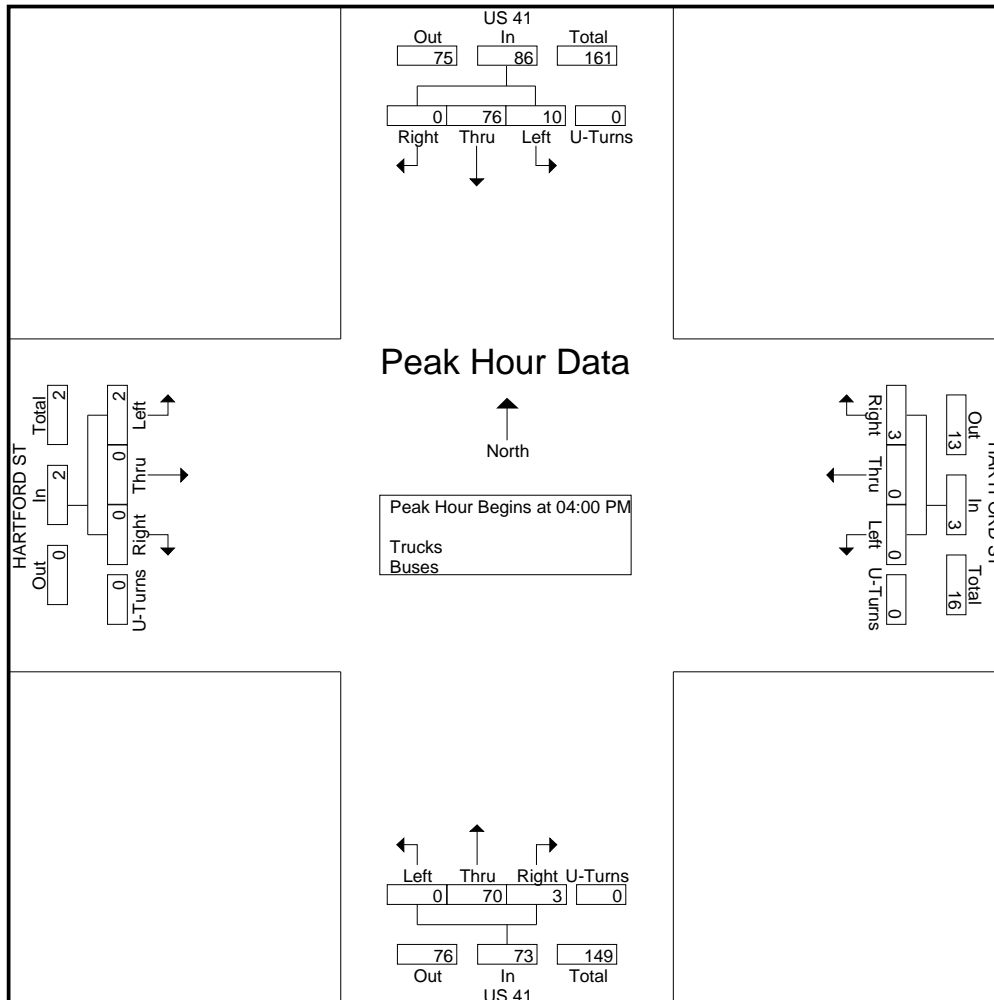



# Southern Traffic Services, Inc.

2911 Westfield Rd  
 Gulf Breeze, FL 32563  
 1-800-786-3374

*Traffic is our only business!*

US 41 @ Hartford St  
 Tampa, FL

File Name : 13015-11 US 41 @ Hartford St Peds  
 Site Code : 13015-11  
 Start Date : 1/8/2013  
 Page No : 1

Groups Printed- Peds

Start Time	US 41	HARTFORD ST	US 41	HARTFORD ST	Int. Total
	Southbound	Westbound	Northbound	Eastbound	
	Peds	Peds	Peds	Peds	
07:00 AM	0	0	0	0	0
07:15 AM	0	0	0	0	0
07:30 AM	0	0	0	0	0
07:45 AM	0	0	0	0	0
Total	0	0	0	0	0
08:00 AM	0	0	0	0	0
08:15 AM	0	0	1	1	2
08:30 AM	0	0	0	0	0
08:45 AM	0	0	0	0	0
Total	0	0	1	1	2
09:00 AM	0	0	0	0	0
09:15 AM	0	0	0	0	0
09:30 AM	0	0	0	0	0
09:45 AM	0	0	0	0	0
Total	0	0	0	0	0
10:00 AM	0	0	0	0	0
10:15 AM	0	0	0	0	0
10:30 AM	0	0	0	0	0
10:45 AM	0	0	0	0	0
Total	0	0	0	0	0
11:00 AM	0	0	0	0	0
11:15 AM	0	0	0	0	0
11:30 AM	0	0	0	0	0
11:45 AM	0	0	0	0	0
Total	0	0	0	0	0
12:00 PM	0	0	0	0	0
12:15 PM	0	0	0	0	0
12:30 PM	0	0	0	0	0
12:45 PM	0	0	0	0	0
Total	0	0	0	0	0
01:00 PM	0	0	0	0	0
01:15 PM	0	0	0	0	0
01:30 PM	0	0	0	0	0
01:45 PM	0	0	0	0	0
Total	0	0	0	0	0
02:00 PM	0	0	0	0	0
02:15 PM	0	0	0	0	0
02:30 PM	0	0	0	0	0
02:45 PM	0	0	0	0	0
Total	0	0	0	0	0
03:00 PM	0	0	0	0	0
03:15 PM	0	0	0	0	0
03:30 PM	0	0	0	0	0
03:45 PM	0	0	0	0	0
Total	0	0	0	0	0



# Southern Traffic Services, Inc.

2911 Westfield Rd  
 Gulf Breeze, FL 32563  
 1-800-786-3374

*Traffic is our only business!*

US 41 @ Hartford St  
 Tampa, FL

File Name : 13015-11 US 41 @ Hartford St Peds  
 Site Code : 13015-11  
 Start Date : 1/8/2013  
 Page No : 2

Groups Printed- Peds

	US 41 Southbound	HARTFORD ST Westbound	US 41 Northbound	HARTFORD ST Eastbound	Int. Total
Start Time	Peds	Peds	Peds	Peds	
04:00 PM	1	0	0	0	1
04:15 PM	1	0	0	0	1
04:30 PM	0	0	1	0	1
04:45 PM	0	0	0	0	0
Total	2	0	1	0	3
05:00 PM	1	0	0	0	1
05:15 PM	0	0	1	0	1
05:30 PM	0	0	0	0	0
05:45 PM	0	0	0	0	0
Total	1	0	1	0	2
Grand Total	3	0	3	1	7
Aprch %	100	0	100	100	
Total %	42.9	0	42.9	14.3	

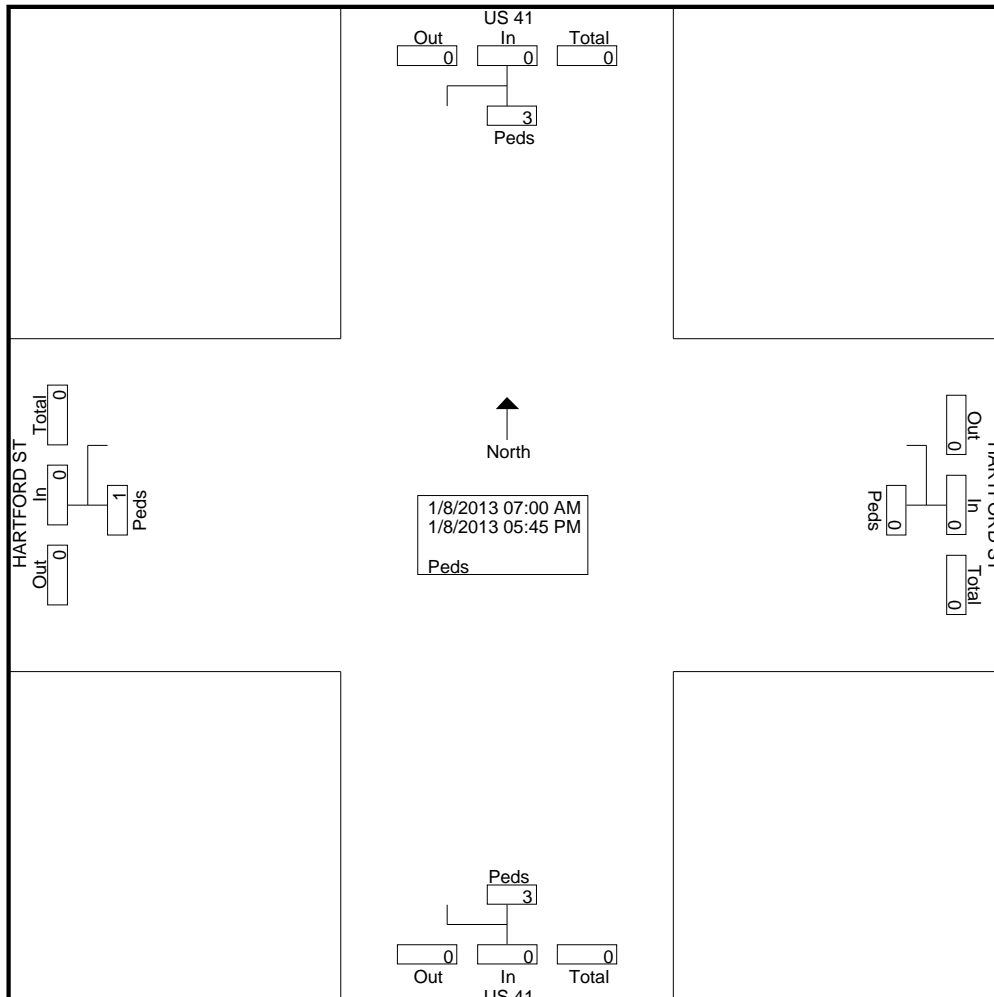

# Southern Traffic Services, Inc.

## Event Counts

**US 41 north of Hartford Street**

**Northbound**

**Datasets:**

**Site:** [111] I3  
**Input A:** 7 - North bound A>B, South bound B>A. - Added to totals. (1)  
**Input B:** 0 - Unused or unknown. - Excluded from totals. (0)  
**Survey Duration:** 12:03 Monday, January 07, 2013 => 12:10 Friday, January 11, 2013  
**File:** G:\DATA\2013\Private\13015\diego\Data 1-7-13\UM111.eco (Plus)  
**Identifier:** P576KJ52 MC56-L5 [MC55] (c)Microcom 19Oct04  
**Algorithm:** Event Count  
**Data type:** Axle sensors - Paired (Class, Speed, Count)

**Profile:**

**Filter time:** 0:00 Tuesday, January 08, 2013 => 0:00 Friday, January 11, 2013  
**Name:** Factory default profile  
**Scheme:** Count events divided by two.  
**Units:** Non metric (ft, mi, ft/s, mph, lb, ton)  
**In profile:** Events = 50822

**Tuesday, January 08, 2013=16881, 15 minute drops**

0000	0100	0200	0300	0400	0500	0600	0700	0800	0900	1000	1100	1200	1300	1400	1500	1600	1700	1800	1900	2000	2100	2200	2300	
72	69	63	157	299	722	1555	2375	1548	1009	926	874	963	898	899	1028	900	888	622	343	227	183	162	99	
21	21	15	25	55	127	308	624	456	258	255	219	267	226	185	266	247	260	186	105	51	45	47	31	20
17	17	13	24	58	163	387	590	418	286	233	234	216	157	253	231	230	216	186	86	54	43	46	20	23
15	18	27	51	79	192	279	612	375	231	194	204	246	271	223	315	238	216	142	92	66	52	37	28	21
19	13	8	57	107	240	581	549	299	234	244	217	234	244	238	216	185	196	108	60	56	43	32	20	19

AM Peak 0645 - 0745 (2407), AM PHF=0.96 PM Peak 1445 - 1545 (1050), PM PHF=0.83

**Wednesday, January 09, 2013=16977, 15 minute drops**

0000	0100	0200	0300	0400	0500	0600	0700	0800	0900	1000	1100	1200	1300	1400	1500	1600	1700	1800	1900	2000	2100	2200	2300	
83	84	89	136	311	782	1711	2319	1538	985	895	751	972	829	920	1004	947	874	624	378	209	262	165	109	
20	18	40	18	61	137	319	616	498	276	245	206	287	183	254	262	242	251	159	120	54	75	46	46	25
23	30	15	28	57	160	418	554	368	230	215	209	210	239	236	211	247	213	162	107	48	73	49	27	12
21	18	18	39	94	230	522	585	395	230	209	182	250	187	202	286	260	196	174	80	55	62	44	16	11
19	18	16	51	99	255	452	564	277	249	226	154	225	220	228	245	198	214	129	71	52	52	26	20	18

AM Peak 0700 - 0800 (2319), AM PHF=0.94 PM Peak 1530 - 1630 (1020), PM PHF=0.89

**Thursday, January 10, 2013=16964, 15 minute drops**

0000	0100	0200	0300	0400	0500	0600	0700	0800	0900	1000	1100	1200	1300	1400	1500	1600	1700	1800	1900	2000	2100	2200	2300	
66	63	64	104	288	778	1679	2257	1540	1041	819	910	846	907	944	1061	929	871	631	387	261	221	188	109	
25	24	10	12	32	134	321	483	467	296	172	246	227	232	245	264	252	227	179	128	63	63	46	20	19
12	11	21	25	67	169	397	566	458	253	237	196	190	229	243	246	240	225	190	108	75	64	58	44	19
11	19	19	37	96	245	397	620	344	250	200	228	220	231	216	330	228	211	160	86	75	52	52	25	21
18	9	14	30	93	230	564	588	271	242	210	240	209	215	240	221	209	208	102	65	48	42	32	20	12

AM Peak 0700 - 0800 (2257), AM PHF=0.91 PM Peak 1445 - 1545 (1080), PM PHF=0.82



# Southern Traffic Services, Inc.

## Event Counts

**US 41 north of Hartford Street**

**Southbound**

**Datasets:**

**Site:** [111] I3  
**Input A:** 7 - North bound A>B, South bound B>A. - Excluded from totals. (0)  
**Input B:** 0 - Unused or unknown. - Added to totals. (1)  
**Survey Duration:** 12:03 Monday, January 07, 2013 => 12:10 Friday, January 11, 2013  
**File:** G:\DATA\2013\Private\13015\diego\Data 1-7-13\UM111.eco (Plus)  
**Identifier:** P576KJ52 MC56-L5 [MC55] (c)Microcom 19Oct04  
**Algorithm:** Event Count  
**Data type:** Axle sensors - Paired (Class, Speed, Count)

**Profile:**

**Filter time:** 0:00 Tuesday, January 08, 2013 => 0:00 Friday, January 11, 2013  
**Name:** Factory default profile  
**Scheme:** Count events divided by two.  
**Units:** Non metric (ft, mi, ft/s, mph, lb, ton)  
**In profile:** Events = 54269

**Tuesday, January 08, 2013=18203, 15 minute drops**

0000	0100	0200	0300	0400	0500	0600	0700	0800	0900	1000	1100	1200	1300	1400	1500	1600	1700	1800	1900	2000	2100	2200	2300	
206	130	114	135	207	421	798	855	873	819	739	838	898	915	810	1532	1853	2201	1498	794	576	417	321	253	
98	36	28	15	48	62	192	234	236	233	177	190	235	186	238	375	375	544	472	229	165	108	115	62	29
49	38	34	38	34	94	186	207	246	196	197	208	207	276	236	339	470	581	418	181	172	97	86	79	33
31	25	28	43	53	129	210	180	200	209	190	207	235	243	241	405	500	533	344	205	134	112	77	58	30
28	31	24	39	72	136	210	234	191	181	175	233	221	210	95	413	508	543	264	179	105	100	43	54	21

AM Peak 0745 - 0845 (916), AM PHF=0.93 PM Peak 1700 - 1800 (2201), PM PHF=0.95

**Wednesday, January 09, 2013=17994, 15 minute drops**

0000	0100	0200	0300	0400	0500	0600	0700	0800	0900	1000	1100	1200	1300	1400	1500	1600	1700	1800	1900	2000	2100	2200	2300	
113	157	113	107	223	491	659	956	766	749	736	912	819	887	1046	1391	1880	2218	1398	675	547	494	371	286	
29	54	34	23	50	69	178	305	191	190	189	226	187	202	267	282	465	616	433	141	147	142	104	77	52
33	37	34	39	56	104	142	223	210	192	169	220	208	241	224	365	445	511	417	202	153	104	110	62	45
30	40	20	25	62	162	227	220	183	176	195	249	232	210	269	321	473	563	308	189	127	142	64	73	26
21	26	25	20	55	156	112	208	182	191	183	217	192	234	286	423	497	528	240	143	120	106	93	74	44

AM Peak 0700 - 0800 (956), AM PHF=0.78 PM Peak 1700 - 1800 (2218), PM PHF=0.90

**Thursday, January 10, 2013=18072, 15 minute drops**

0000	0100	0200	0300	0400	0500	0600	0700	0800	0900	1000	1100	1200	1300	1400	1500	1600	1700	1800	1900	2000	2100	2200	2300	
167	110	119	136	236	391	805	838	635	816	754	800	973	895	1055	1388	1859	2152	1443	775	610	445	398	272	
52	41	38	26	46	58	176	187	181	294	149	173	216	225	255	307	423	536	376	257	156	111	100	78	48
45	29	26	32	64	82	190	219	186	154	179	130	289	135	263	297	465	562	437	213	173	140	106	63	60
26	32	29	39	45	132	134	201	191	163	208	276	250	307	253	402	462	570	357	175	132	90	96	71	53
44	8	26	39	81	119	305	231	77	205	218	221	218	228	284	382	509	484	273	130	149	104	96	60	16

AM Peak 1130 - 1230 (1002), AM PHF=0.87 PM Peak 1645 - 1745 (2177), PM PHF=0.95

# Southern Traffic Services, Inc.

## Event Counts

US 41 south of Hartford Street

Northbound

**Datasets:**

**Site:** [112] !C5166  
**Input A:** 7 - North bound A>B, South bound B>A. - Added to totals. (1)  
**Input B:** 0 - Unused or unknown. - Excluded from totals. (0)  
**Survey Duration:** 8:56 Monday, January 28, 2013 => 12:01 Friday, February 01, 2013  
**File:** G:\DATA\2013\Private\13015\diego0128\13015\UM1122.eco (Plus)  
**Identifier:** R182KAGM MC56-L5 [MC55] (c)Microcom 19Oct04  
**Algorithm:** Event Count  
**Data type:** Axle sensors - Paired (Class, Speed, Count)

**Profile:**

**Filter time:** 0:00 Tuesday, January 29, 2013 => 0:00 Friday, February 01, 2013  
**Name:** Factory default profile  
**Scheme:** Count events divided by two.  
**Units:** Non metric (ft, mi, ft/s, mph, lb, ton)  
**In profile:** Events = 50290

**Tuesday, January 29, 2013=16764, 15 minute drops**

0000	0100	0200	0300	0400	0500	0600	0700	0800	0900	1000	1100	1200	1300	1400	1500	1600	1700	1800	1900	2000	2100	2200	2300	
59	54	54	117	274	657	1721	2092	1575	1066	880	943	926	921	993	1160	881	885	569	299	231	183	149	75	
20	21	14	26	58	63	441	466	514	291	219	251	256	236	226	277	235	266	173	85	82	48	53	28	22
17	9	12	21	52	184	403	585	330	282	208	223	268	228	225	256	185	234	156	81	34	52	41	17	8
9	10	9	38	82	210	445	564	385	257	225	227	208	234	281	346	257	201	138	78	59	41	30	15	7
13	14	19	32	82	200	432	477	346	236	228	242	194	223	261	281	204	184	102	55	56	42	25	15	16

AM Peak 0715 - 0815 (2140), AM PHF=0.91 PM Peak 1500 - 1600 (1160), PM PHF=0.84

**Wednesday, January 30, 2013=16974, 15 minute drops**

0000	0100	0200	0300	0400	0500	0600	0700	0800	0900	1000	1100	1200	1300	1400	1500	1600	1700	1800	1900	2000	2100	2200	2300	
53	53	52	113	284	715	1563	2170	1675	1005	957	943	900	876	986	1135	913	832	672	346	245	243	144	99	
22	14	11	20	53	126	297	486	503	293	275	262	255	220	280	287	248	255	194	114	70	75	27	26	18
8	7	10	22	57	169	105	564	522	286	238	212	221	209	232	275	214	204	153	95	61	60	46	20	14
7	19	13	37	79	194	619	527	328	229	195	234	223	234	215	282	234	205	183	72	61	58	39	30	18
16	13	18	34	95	226	542	593	322	197	249	235	201	213	259	291	217	168	142	65	53	50	32	23	5

AM Peak 0630 - 0730 (2211), AM PHF=0.89 PM Peak 1500 - 1600 (1135), PM PHF=0.98

**Thursday, January 31, 2013=16552, 15 minute drops**

0000	0100	0200	0300	0400	0500	0600	0700	0800	0900	1000	1100	1200	1300	1400	1500	1600	1700	1800	1900	2000	2100	2200	2300	
55	50	62	123	243	713	1649	2126	1541	975	831	841	933	891	917	1035	959	858	651	358	234	222	179	106	
18	16	17	26	32	116	316	444	454	215	211	203	244	215	212	274	233	257	192	121	69	71	58	37	27
14	13	20	24	51	174	394	559	403	292	200	145	223	263	244	282	238	196	169	93	65	56	52	25	12
18	13	14	47	65	200	439	564	383	229	217	288	256	176	234	193	241	199	141	79	54	51	39	24	10
5	8	11	26	95	223	500	559	301	239	203	205	210	237	227	286	247	206	149	65	46	44	30	20	20

AM Peak 0715 - 0815 (2136), AM PHF=0.95 PM Peak 1500 - 1600 (1035), PM PHF=0.90

# Southern Traffic Services, Inc.

## Event Counts

**US 41 south of Hartford Street**

**Southbound**

**Datasets:**

**Site:** [112] !C5166  
**Input A:** 7 - North bound A>B, South bound B>A. - Excluded from totals. (0)  
**Input B:** 0 - Unused or unknown. - Added to totals. (1)  
**Survey Duration:** 8:56 Monday, January 28, 2013 => 12:01 Friday, February 01, 2013  
**File:** G:\DATA\2013\Private\13015\diego0128\13015\UM1122.eco (Plus)  
**Identifier:** R182KAGM MC56-L5 [MC55] (c)Microcom 19Oct04  
**Algorithm:** Event Count  
**Data type:** Axle sensors - Paired (Class, Speed, Count)

**Profile:**

**Filter time:** 0:00 Tuesday, January 29, 2013 => 0:00 Friday, February 01, 2013  
**Name:** Factory default profile  
**Scheme:** Count events divided by two.  
**Units:** Non metric (ft, mi, ft/s, mph, lb, ton)  
**In profile:** Events = 53996

**Tuesday, January 29, 2013=17873, 15 minute drops**

0000	0100	0200	0300	0400	0500	0600	0700	0800	0900	1000	1100	1200	1300	1400	1500	1600	1700	1800	1900	2000	2100	2200	2300	
136	113	89	119	182	308	875	822	774	774	825	889	815	918	1154	1312	1906	2183	1364	831	524	454	300	206	
52	28	10	28	28	58	252	181	207	193	175	201	193	238	265	279	484	543	488	242	136	136	82	55	30
35	30	27	12	43	92	202	211	212	212	234	185	196	204	257	292	437	568	354	223	130	126	78	45	36
22	25	19	42	59	58	201	225	156	207	196	245	222	268	321	274	494	584	274	201	148	103	80	49	42
27	30	33	37	52	100	220	205	199	162	220	258	204	208	311	467	491	488	248	165	110	89	60	57	21

AM Peak 1130 - 1230 (892), AM PHF=0.86 PM Peak 1645 - 1745 (2186), PM PHF=0.94

**Wednesday, January 30, 2013=18052, 15 minute drops**

0000	0100	0200	0300	0400	0500	0600	0700	0800	0900	1000	1100	1200	1300	1400	1500	1600	1700	1800	1900	2000	2100	2200	2300	
129	96	80	137	164	528	797	811	824	745	530	942	853	908	1049	1414	1912	2179	1557	785	549	438	372	253	
30	36	14	22	38	80	146	195	171	174	183	318	202	212	258	273	406	536	501	232	147	126	135	51	40
36	20	15	30	47	112	207	150	245	175	164	193	235	217	256	327	331	545	436	219	141	124	78	73	36
42	23	24	45	29	163	201	222	212	215	155	254	211	248	261	383	660	527	368	186	122	78	82	67	30
21	17	27	40	50	173	243	244	196	181	28	177	205	231	274	431	515	571	252	148	139	110	77	62	27

AM Peak 1100 - 1200 (942), AM PHF=0.74 PM Peak 1630 - 1730 (2256), PM PHF=0.85

**Thursday, January 31, 2013=18071, 15 minute drops**

0000	0100	0200	0300	0400	0500	0600	0700	0800	0900	1000	1100	1200	1300	1400	1500	1600	1700	1800	1900	2000	2100	2200	2300	
133	99	93	139	169	479	791	862	770	641	726	850	892	871	1087	1428	1700	2314	1518	821	566	486	378	258	
40	23	17	27	27	73	152	211	226	166	172	203	240	228	214	284	436	594	467	233	143	133	119	76	34
36	22	34	36	28	89	211	208	206	169	173	199	213	198	292	345	449	651	443	202	159	116	90	63	43
30	28	23	35	53	131	219	223	175	155	190	218	219	234	275	416	443	464	355	200	146	127	89	66	46
27	26	19	41	61	186	209	220	163	151	191	230	220	211	306	383	372	605	253	186	118	110	80	53	42

AM Peak 1145 - 1245 (902), AM PHF=0.94 PM Peak 1700 - 1800 (2314), PM PHF=0.89

# Southern Traffic Services, Inc.

## Event Counts

**Hartford Street east of US 41**

**Eastbound**

**Datasets:**

**Site:** [113] !C1105  
**Input A:** 6 - West bound A>B, East bound B>A. - Added to totals. (1)  
**Input B:** 0 - Unused or unknown. - Subtracted from totals. (-1)  
**Survey Duration:** 17:22 Monday, January 14, 2013 => 15:04 Friday, January 18, 2013  
**File:** G:\DATA\2013\Private\13015\resets\UM113.eco (Plus)  
**Identifier:** DA6185Z1 MC56-L5 [MC55] (c)Microcom 19Oct04  
**Algorithm:** Event Count  
**Data type:** Axle sensors - Paired (Class, Speed, Count)

**Profile:**

**Filter time:** 0:00 Tuesday, January 15, 2013 => 0:00 Friday, January 18, 2013  
**Name:** Factory default profile  
**Scheme:** Count events divided by two.  
**Units:** Non metric (ft, mi, ft/s, mph, lb, ton)  
**In profile:** Events = 2430

**Tuesday, January 15, 2013=811, 15 minute drops**

0000	0100	0200	0300	0400	0500	0600	0700	0800	0900	1000	1100	1200	1300	1400	1500	1600	1700	1800	1900	2000	2100	2200	2300	
6	13	15	10	24	22	48	61	41	51	30	42	44	59	57	68	56	51	36	21	18	20	10	8	
0	3	1	10	6	5	3	10	10	12	9	11	11	15	23	14	11	18	16	7	5	5	5	4	3
3	0	4	0	11	2	11	13	11	7	4	15	12	14	6	31	22	13	6	8	1	6	1	0	4
0	1	7	0	3	8	21	14	15	17	8	9	11	15	16	9	10	12	9	0	2	4	4	1	1
3	9	3	0	4	7	13	24	5	15	9	7	10	15	12	14	13	8	5	6	10	5	0	3	7

AM Peak 0700 - 0800 (61), AM PHF=0.64 PM Peak 1430 - 1530 (73), PM PHF=0.59

**Wednesday, January 16, 2013=847, 15 minute drops**

0000	0100	0200	0300	0400	0500	0600	0700	0800	0900	1000	1100	1200	1300	1400	1500	1600	1700	1800	1900	2000	2100	2200	2300	
15	5	14	11	11	46	47	62	51	53	56	24	56	53	63	76	71	41	41	19	18	4	1	9	
3	2	6	3	0	8	10	15	15	6	15	8	8	18	24	14	22	6	10	7	3	0	0	1	0
4	3	0	4	3	11	4	20	15	10	11	4	25	11	26	8	10	14	12	6	2	0	0	6	7
1	0	6	1	0	4	23	18	10	14	14	5	11	11	7	27	18	7	16	7	5	2	1	1	0
7	0	2	3	8	23	10	9	11	23	16	7	12	13	6	27	21	14	3	-1	8	2	0	1	0

AM Peak 0630 - 0730 (68), AM PHF=0.74 PM Peak 1530 - 1630 (86), PM PHF=0.80

**Thursday, January 17, 2013=772, 15 minute drops**

0000	0100	0200	0300	0400	0500	0600	0700	0800	0900	1000	1100	1200	1300	1400	1500	1600	1700	1800	1900	2000	2100	2200	2300	
7	14	12	12	8	27	50	59	52	36	44	46	46	60	59	61	48	53	26	14	21	8	3	6	
0	4	4	1	3	11	5	18	20	7	7	8	11	25	18	19	12	25	8	4	2	2	3	1	0
7	1	3	2	1	0	4	7	11	16	7	9	10	12	17	10	16	9	4	5	2	2	0	3	2
0	3	5	4	2	6	20	29	10	3	14	8	13	10	14	13	6	7	11	4	10	2	0	1	1
0	6	0	5	2	10	21	5	11	10	16	21	12	13	10	19	14	12	3	1	7	2	0	1	0

AM Peak 0645 - 0745 (75), AM PHF=0.65 PM Peak 1230 - 1330 (62), PM PHF=0.62

# Southern Traffic Services, Inc.

## Event Counts

**Hartford Street east of US 41**

**Westbound**

**Datasets:**

**Site:** [113] !C1105  
**Input A:** 6 - West bound A>B, East bound B>A. - Excluded from totals. (0)  
**Input B:** 0 - Unused or unknown. - Added to totals. (1)  
**Survey Duration:** 17:22 Monday, January 14, 2013 => 15:04 Friday, January 18, 2013  
**File:** G:\DATA\2013\Private\13015\resets\UM113.eco (Plus)  
**Identifier:** DA6185Z1 MC56-L5 [MC55] (c)Microcom 19Oct04  
**Algorithm:** Event Count  
**Data type:** Axle sensors - Paired (Class, Speed, Count)

**Profile:**

**Filter time:** 0:00 Tuesday, January 15, 2013 => 0:00 Friday, January 18, 2013  
**Name:** Factory default profile  
**Scheme:** Count events divided by two.  
**Units:** Non metric (ft, mi, ft/s, mph, lb, ton)  
**In profile:** Events = 2416

**Tuesday, January 15, 2013=787, 15 minute drops**

0000	0100	0200	0300	0400	0500	0600	0700	0800	0900	1000	1100	1200	1300	1400	1500	1600	1700	1800	1900	2000	2100	2200	2300	
5	12	10	11	15	29	48	76	38	35	34	51	36	44	67	51	60	58	42	22	11	15	10	7	
3	3	3	4	3	5	9	21	9	7	11	11	9	11	13	7	17	17	11	10	6	4	4	3	6
0	2	5	4	2	7	19	13	13	13	4	12	7	9	26	10	13	11	13	0	2	2	1	1	2
0	3	0	3	3	9	9	22	9	8	10	12	10	6	16	20	20	11	8	6	2	8	3	1	2
2	4	2	0	7	8	11	20	7	7	9	16	10	18	12	14	10	19	10	6	1	1	2	2	2

AM Peak 0700 - 0800 (76), AM PHF=0.86 PM Peak 1345 - 1445 (73), PM PHF=0.70

**Wednesday, January 16, 2013=857, 15 minute drops**

0000	0100	0200	0300	0400	0500	0600	0700	0800	0900	1000	1100	1200	1300	1400	1500	1600	1700	1800	1900	2000	2100	2200	2300	
12	8	5	16	16	26	49	71	49	55	43	55	49	42	58	45	60	63	61	34	11	18	7	4	
6	3	2	5	2	5	11	17	10	17	16	8	10	9	15	11	21	17	17	7	4	5	5	0	1
2	1	0	5	7	2	9	7	13	5	9	20	13	10	19	8	17	15	18	8	3	2	0	2	1
2	2	1	1	3	9	18	21	13	15	9	14	15	15	12	12	8	16	10	14	3	5	0	1	4
2	2	2	5	4	10	11	26	13	18	9	13	11	8	12	14	14	15	16	5	1	6	2	1	3

AM Peak 0700 - 0800 (71), AM PHF=0.68 PM Peak 1730 - 1830 (66), PM PHF=0.92

**Thursday, January 17, 2013=772, 15 minute drops**

0000	0100	0200	0300	0400	0500	0600	0700	0800	0900	1000	1100	1200	1300	1400	1500	1600	1700	1800	1900	2000	2100	2200	2300	
9	8	9	14	18	22	43	64	42	32	48	42	41	53	53	61	43	69	44	25	10	13	7	2	
1	3	2	2	3	5	9	11	12	6	16	16	14	12	15	19	10	20	18	8	4	2	4	0	4
1	2	1	3	5	7	9	13	17	8	9	7	9	20	17	17	16	11	7	6	3	2	1	0	2
4	1	1	3	4	5	5	19	5	8	14	9	5	11	14	15	11	24	10	6	1	4	1	0	2
3	2	5	6	6	5	20	21	8	10	9	10	13	10	7	10	6	14	9	5	2	5	1	2	1

AM Peak 0730 - 0830 (69), AM PHF=0.82 PM Peak 1700 - 1800 (69), PM PHF=0.72

# Southern Traffic Services, Inc.

## Event Counts

**Hartford Street west of US 41**

**Eastbound**

**Datasets:**

**Site:** [114] ICC  
**Input A:** 8 - East bound A>B, West bound B>A. - Added to totals. (1)  
**Input B:** 0 - Unused or unknown. - Subtracted from totals. (-1)  
**Survey Duration:** 8:01 Monday, January 28, 2013 => 11:22 Friday, February 01, 2013  
**File:** G:\DATA\2013\Private\13015\diego0128\13015\UM114.eco (Plus)  
**Identifier:** A958WCNG MC56-1 [MC55] (c)Microcom 07/06/99  
**Algorithm:** Event Count  
**Data type:** Axle sensors - Paired (Class, Speed, Count)

**Profile:**

**Filter time:** 0:00 Tuesday, January 29, 2013 => 0:00 Friday, February 01, 2013  
**Name:** Factory default profile  
**Scheme:** Count events divided by two.  
**Units:** Non metric (ft, mi, ft/s, mph, lb, ton)  
**In profile:** Events = 432

**Tuesday, January 29, 2013=152, 15 minute drops**

0000	0100	0200	0300	0400	0500	0600	0700	0800	0900	1000	1100	1200	1300	1400	1500	1600	1700	1800	1900	2000	2100	2200	2300
0	0	0	1	0	1	6	5	5	17	9	9	17	15	8	13	23	12	3	3	2	2	1	0
0	0	0	0	0	0	1	1	1	2	1	3	5	5	1	3	8	7	1	0	0	0	1	0
0	0	0	0	0	0	2	1	0	3	2	1	6	4	4	4	4	2	1	1	2	0	0	0
0	0	0	0	0	0	2	3	0	7	3	2	4	5	2	1	5	1	0	1	0	2	0	0
0	0	0	1	0	1	0	4	5	3	3	2	1	1	5	6	2	1	1	0	0	0	0	0

AM Peak 1145 - 1245 (18), AM PHF=0.75 PM Peak 1600 - 1700 (23), PM PHF=0.72

**Wednesday, January 30, 2013=142, 15 minute drops**

0000	0100	0200	0300	0400	0500	0600	0700	0800	0900	1000	1100	1200	1300	1400	1500	1600	1700	1800	1900	2000	2100	2200	2300
0	0	1	0	2	3	6	10	8	12	14	8	17	8	8	8	21	8	5	0	0	3	0	0
0	0	0	0	0	1	0	3	1	3	3	2	6	1	1	4	12	5	0	0	0	0	0	0
0	0	0	0	1	0	2	4	1	2	2	1	2	1	2	3	4	1	1	0	0	1	0	0
0	0	1	0	1	1	2	0	3	2	3	1	4	4	5	1	2	2	3	0	0	2	0	0
0	0	0	0	0	1	2	3	3	5	6	4	5	2	0	0	3	0	1	0	0	0	0	0

AM Peak 1145 - 1245 (16), AM PHF=0.67 PM Peak 1600 - 1700 (21), PM PHF=0.44

**Thursday, January 31, 2013=138, 15 minute drops**

0000	0100	0200	0300	0400	0500	0600	0700	0800	0900	1000	1100	1200	1300	1400	1500	1600	1700	1800	1900	2000	2100	2200	2300
0	0	0	0	4	0	4	5	5	10	14	15	16	7	9	11	25	9	4	0	0	0	0	0
0	0	0	0	1	0	0	2	1	1	6	2	7	1	5	1	10	3	0	0	0	0	0	0
0	0	0	0	0	0	2	1	0	4	2	7	3	3	2	4	6	3	1	0	0	0	0	0
0	0	0	0	1	0	1	1	2	4	3	2	2	1	1	2	2	1	1	0	0	0	0	0
0	0	0	0	2	0	1	1	2	1	3	4	4	2	1	4	7	2	2	0	0	0	0	0

AM Peak 1115 - 1215 (20), AM PHF=0.71 PM Peak 1600 - 1700 (25), PM PHF=0.63

# Southern Traffic Services, Inc.

## Event Counts

**Hartford Street west of US 41**

**Westbound**

**Datasets:**

**Site:** [114] ICC  
**Input A:** 8 - East bound A>B, West bound B>A. - Excluded from totals. (0)  
**Input B:** 0 - Unused or unknown. - Added to totals. (1)  
**Survey Duration:** 8:01 Monday, January 28, 2013 => 11:22 Friday, February 01, 2013  
**File:** G:\DATA\2013\Private\13015\diego0128\13015\UM114.eco (Plus)  
**Identifier:** A958WCNG MC56-1 [MC55] (c)Microcom 07/06/99  
**Algorithm:** Event Count  
**Data type:** Axle sensors - Paired (Class, Speed, Count)

**Profile:**

**Filter time:** 0:00 Tuesday, January 29, 2013 => 0:00 Friday, February 01, 2013  
**Name:** Factory default profile  
**Scheme:** Count events divided by two.  
**Units:** Non metric (ft, mi, ft/s, mph, lb, ton)  
**In profile:** Events = 408

**Tuesday, January 29, 2013=143, 15 minute drops**

0000	0100	0200	0300	0400	0500	0600	0700	0800	0900	1000	1100	1200	1300	1400	1500	1600	1700	1800	1900	2000	2100	2200	2300
0	0	1	1	0	2	3	20	6	18	17	15	7	17	9	10	11	2	0	3	1	0	0	0
0	0	0	0	0	0	0	2	1	4	3	2	2	8	2	0	3	0	0	3	1	0	0	0
0	0	0	0	0	2	0	9	2	8	5	1	3	2	3	5	1	1	0	0	0	0	0	0
0	0	1	1	0	0	2	6	1	4	5	5	2	0	1	3	1	1	0	0	0	0	0	0
0	0	0	0	0	0	1	3	2	2	4	7	0	7	3	2	6	0	0	0	0	0	0	0

AM Peak 0700 - 0800 (20), AM PHF=0.56 PM Peak 1300 - 1400 (17), PM PHF=0.53

**Wednesday, January 30, 2013=138, 15 minute drops**

0000	0100	0200	0300	0400	0500	0600	0700	0800	0900	1000	1100	1200	1300	1400	1500	1600	1700	1800	1900	2000	2100	2200	2300
0	0	0	0	0	0	4	14	9	2	10	22	28	12	7	13	7	5	3	0	0	2	0	0
0	0	0	0	0	0	0	0	3	0	2	2	5	5	0	5	1	1	1	0	0	0	0	0
0	0	0	0	0	0	0	9	3	1	3	8	12	2	3	5	0	4	0	0	0	1	0	0
0	0	0	0	0	0	0	5	3	1	1	5	5	4	0	1	5	0	2	0	0	1	0	0
0	0	0	0	0	0	4	0	0	0	4	7	6	1	4	2	1	0	0	0	0	0	0	0

AM Peak 1130 - 1230 (29), AM PHF=0.60 PM Peak 1200 - 1300 (28), PM PHF=0.58

**Thursday, January 31, 2013=127, 15 minute drops**

0000	0100	0200	0300	0400	0500	0600	0700	0800	0900	1000	1100	1200	1300	1400	1500	1600	1700	1800	1900	2000	2100	2200	2300
0	0	0	0	0	0	8	21	8	10	3	6	18	10	11	15	10	3	3	1	0	0	0	0
0	0	0	0	0	0	0	3	1	3	1	3	3	3	5	1	0	1	3	0	0	0	0	0
0	0	0	0	0	0	0	6	4	1	1	1	9	4	0	3	5	1	0	0	0	0	0	0
0	0	0	0	0	0	3	7	1	1	1	1	2	3	5	4	4	0	0	0	0	0	0	0
0	0	0	0	0	0	5	5	2	5	0	1	4	0	1	7	1	1	0	1	0	0	0	0

AM Peak 0645 - 0745 (21), AM PHF=0.75 PM Peak 1200 - 1300 (18), PM PHF=0.50



# Southern Traffic Services, Inc.

2911 Westfield Rd  
Gulf Breeze, FL 32563  
1-800-786-3374

*Traffic is our only business!*

US 41 @ Causeway Blvd  
Tampa, FL

File Name : 13015-12 US 41 @ Causeway Blvd  
Site Code : 13015-12  
Start Date : 1/8/2013  
Page No : 1

Groups Printed- Automobiles - Trucks - Buses

Start Time	US 41 Southbound				CAUSEWAY BLVD Westbound				US 41 Northbound				CAUSEWAY BLVD Eastbound				Int. Total
	Left	Thru	Right	U-Turns	Left	Thru	Right	U-Turns	Left	Thru	Right	U-Turns	Left	Thru	Right	U-Turns	
07:00 AM	22	61	13	0	11	249	40	0	380	237	13	0	8	63	80	0	1177
07:15 AM	26	88	16	0	12	210	63	0	362	233	12	0	11	68	89	0	1190
07:30 AM	26	75	10	0	11	259	44	0	309	173	10	0	11	90	59	0	1077
07:45 AM	26	90	11	0	17	183	51	0	350	224	16	0	16	74	95	0	1153
<b>Total</b>	<b>100</b>	<b>314</b>	<b>50</b>	<b>0</b>	<b>51</b>	<b>901</b>	<b>198</b>	<b>0</b>	<b>1401</b>	<b>867</b>	<b>51</b>	<b>0</b>	<b>46</b>	<b>295</b>	<b>323</b>	<b>0</b>	<b>4597</b>
08:00 AM	29	78	14	0	15	192	41	1	246	138	16	0	9	87	96	0	962
08:15 AM	14	92	11	0	12	170	49	0	211	133	16	0	16	83	78	0	885
08:30 AM	34	81	11	0	9	137	30	0	203	130	15	0	6	52	61	1	770
08:45 AM	24	64	8	0	23	115	39	0	137	106	11	1	13	79	70	0	690
<b>Total</b>	<b>101</b>	<b>315</b>	<b>44</b>	<b>0</b>	<b>59</b>	<b>614</b>	<b>159</b>	<b>1</b>	<b>797</b>	<b>507</b>	<b>58</b>	<b>1</b>	<b>44</b>	<b>301</b>	<b>305</b>	<b>1</b>	<b>3307</b>
<b>**BREAK**</b>																	
04:00 PM	45	153	10	0	12	94	35	1	105	117	27	0	24	146	186	0	955
04:15 PM	32	165	8	0	16	96	39	1	87	105	21	0	22	182	238	0	1012
04:30 PM	50	173	10	0	15	84	29	0	120	94	21	0	17	150	248	0	1011
04:45 PM	55	181	4	0	15	70	41	0	84	97	28	0	12	195	276	0	1058
<b>Total</b>	<b>182</b>	<b>672</b>	<b>32</b>	<b>0</b>	<b>58</b>	<b>344</b>	<b>144</b>	<b>2</b>	<b>396</b>	<b>413</b>	<b>97</b>	<b>0</b>	<b>75</b>	<b>673</b>	<b>948</b>	<b>0</b>	<b>4036</b>
05:00 PM	66	190	7	0	12	95	35	1	127	99	28	0	14	223	322	0	1219
05:15 PM	54	240	4	0	19	83	27	0	97	99	25	0	22	181	306	0	1157
05:30 PM	48	186	4	0	8	95	44	0	102	101	22	0	13	222	313	0	1158
05:45 PM	53	181	3	0	11	70	24	0	102	100	9	0	9	173	335	0	1070
<b>Total</b>	<b>221</b>	<b>797</b>	<b>18</b>	<b>0</b>	<b>50</b>	<b>343</b>	<b>130</b>	<b>1</b>	<b>428</b>	<b>399</b>	<b>84</b>	<b>0</b>	<b>58</b>	<b>799</b>	<b>1276</b>	<b>0</b>	<b>4604</b>
<b>Grand Total</b>	<b>604</b>	<b>2098</b>	<b>144</b>	<b>0</b>	<b>218</b>	<b>2202</b>	<b>631</b>	<b>4</b>	<b>3022</b>	<b>2186</b>	<b>290</b>	<b>1</b>	<b>223</b>	<b>2068</b>	<b>2852</b>	<b>1</b>	<b>16544</b>
Apprch %	21.2	73.7	5.1	0	7.1	72.1	20.7	0.1	55	39.8	5.3	0	4.3	40.2	55.4	0	
Total %	3.7	12.7	0.9	0	1.3	13.3	3.8	0	18.3	13.2	1.8	0	1.3	12.5	17.2	0	
Automobiles	565	1871	105	0	192	2064	576	4	2859	1952	254	1	169	1909	2656	1	15178
% Automobiles	93.5	89.2	72.9	0	88.1	93.7	91.3	100	94.6	89.3	87.6	100	75.8	92.3	93.1	100	91.7
Trucks	35	225	36	0	26	132	47	0	163	233	36	0	53	145	192	0	1323
% Trucks	5.8	10.7	25	0	11.9	6	7.4	0	5.4	10.7	12.4	0	23.8	7	6.7	0	8
Buses	4	2	3	0	0	6	8	0	0	1	0	0	1	14	4	0	43
% Buses	0.7	0.1	2.1	0	0	0.3	1.3	0	0	0	0	0	0.4	0.7	0.1	0	0.3





# Southern Traffic Services, Inc.

2911 Westfield Rd  
 Gulf Breeze, FL 32563  
 1-800-786-3374

*Traffic is our only business!*

US 41 @ Causeway Blvd  
 Tampa, FL

File Name : 13015-12 US 41 @ Causeway Blvd  
 Site Code : 13015-12  
 Start Date : 1/8/2013  
 Page No : 2

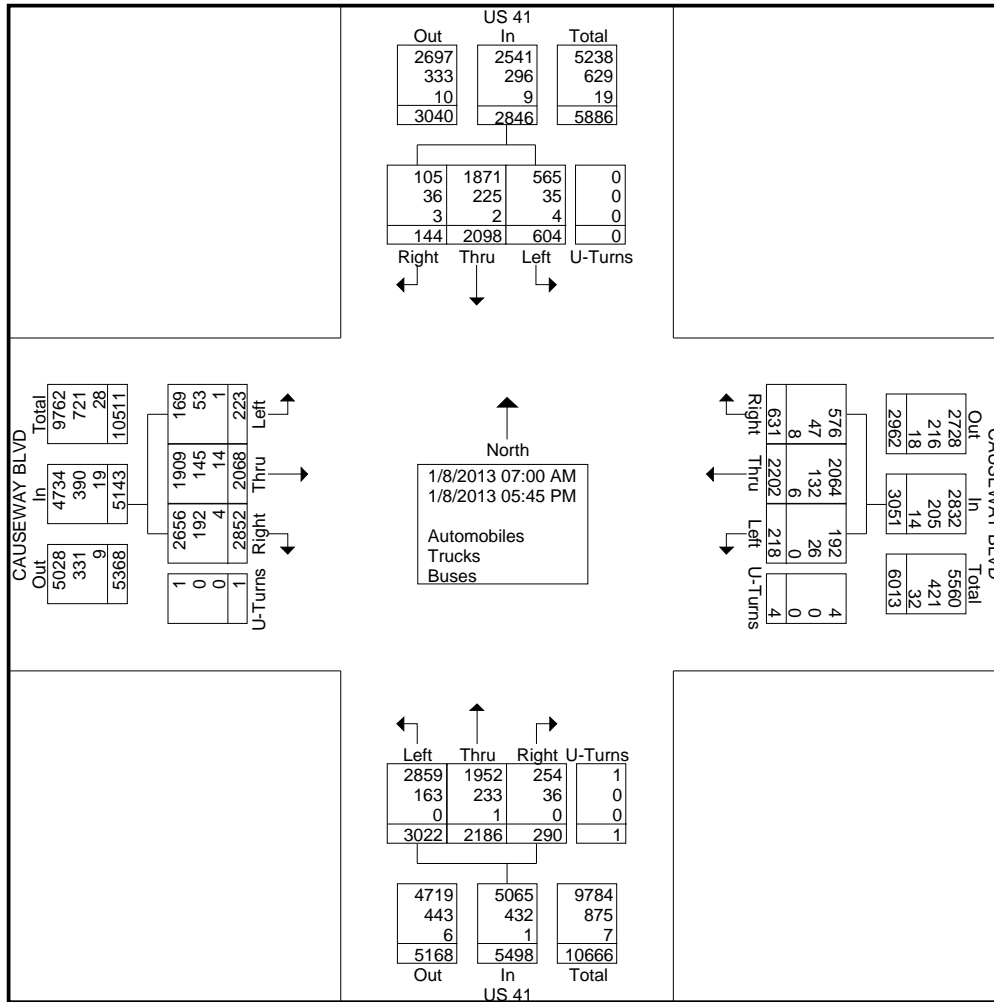



# Southern Traffic Services, Inc.

2911 Westfield Rd  
Gulf Breeze, FL 32563  
1-800-786-3374

*Traffic is our only business!*

US 41 @ Causeway Blvd  
Tampa, FL

File Name : 13015-12 US 41 @ Causeway Blvd  
Site Code : 13015-12  
Start Date : 1/8/2013  
Page No : 3

Start Time	US 41 Southbound				CAUSEWAY BLVD Westbound				US 41 Northbound				CAUSEWAY BLVD Eastbound				Int. Total				
	Thru	Right	U-Turns	App. Total	Left	Thru	Right	U-Turns	App. Total	Left	Thru	Right	U-Turns	App. Total	Left	Thru		Right	U-Turns	App. Total	
Peak Hour Analysis From 07:00 AM to 11:45 AM - Peak 1 of 1																					
Peak Hour for Entire Intersection Begins at 07:00 AM																					
07:00 AM	22	61	13	0	96	11	249	40	0	300	380	237	13	0	630	8	63	80	0	151	1177
07:15 AM	26	88	16	0	130	12	210	63	0	285	362	233	12	0	607	11	68	89	0	168	1190
07:30 AM	26	75	10	0	111	11	259	44	0	314	309	173	10	0	492	11	90	59	0	160	1077
07:45 AM	26	90	11	0	127	17	183	51	0	251	350	224	16	0	590	16	74	95	0	185	1153
Total Volume	100	314	50	0	464	51	901	198	0	1150	1401	867	51	0	2319	46	295	323	0	664	4597
% App. Total	21.6	67.7	10.8	0		4.4	78.3	17.2	0		60.4	37.4	2.2	0		6.9	44.4	48.6	0		
PHF	.962	.872	.781	.000	.892	.750	.870	.786	.000	.916	.922	.915	.797	.000	.920	.719	.819	.850	.000	.897	.966
Automobiles	85	247	40	0	372	48	858	183	0	1089	1348	799	45	0	2192	34	249	269	0	552	4205
% Automobiles	85.0	78.7	80.0	0	80.2	94.1	95.2	92.4	0	94.7	96.2	92.2	88.2	0	94.5	73.9	84.4	83.3	0	83.1	91.5
Trucks	12	65	10	0	87	3	42	14	0	59	53	68	6	0	127	12	43	53	0	108	381
% Trucks	12.0	20.7	20.0	0	18.8	5.9	4.7	7.1	0	5.1	3.8	7.8	11.8	0	5.5	26.1	14.6	16.4	0	16.3	8.3
Buses	3	2	0	0	5	0	1	1	0	2	0	0	0	0	0	0	3	1	0	4	11
% Buses	3.0	0.6	0	0	1.1	0	0.1	0.5	0	0.2	0	0	0	0	0	0	1.0	0.3	0	0.6	0.2

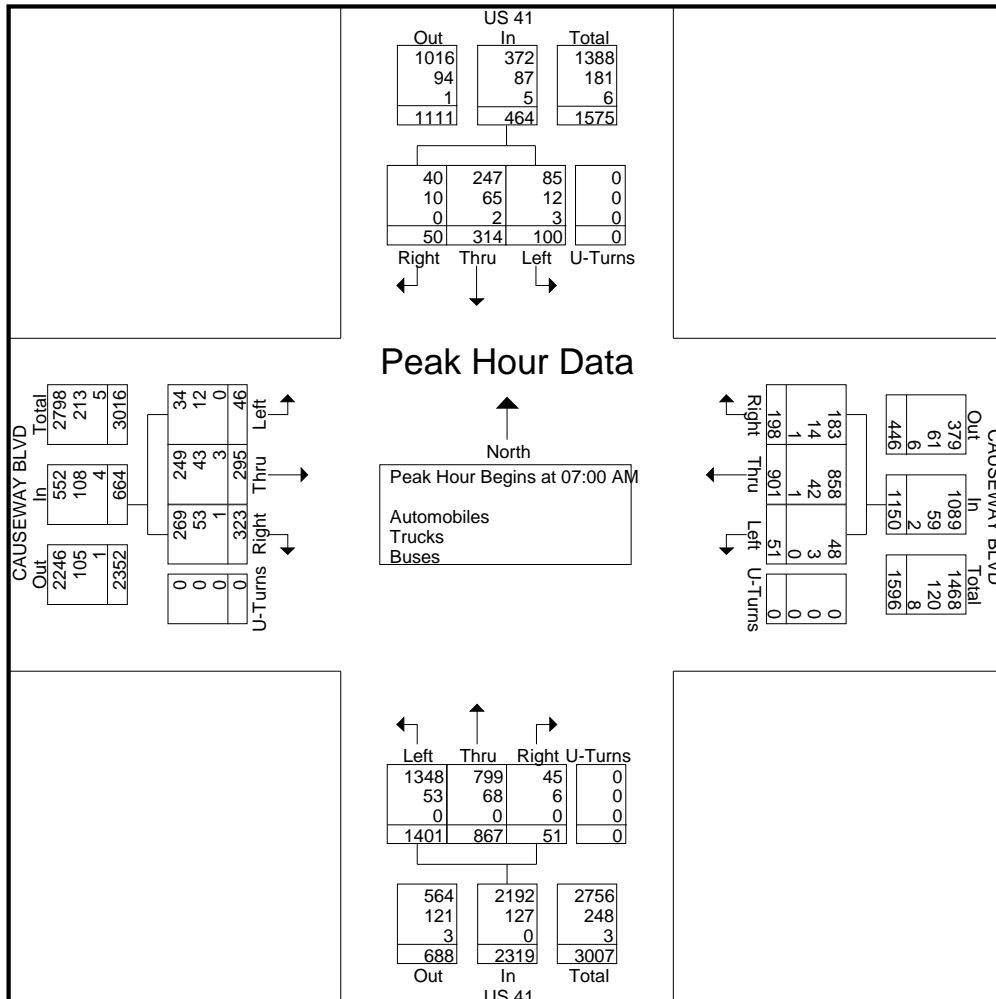



# Southern Traffic Services, Inc.

2911 Westfield Rd  
Gulf Breeze, FL 32563  
1-800-786-3374

*Traffic is our only business!*

US 41 @ Causeway Blvd  
Tampa, FL

File Name : 13015-12 US 41 @ Causeway Blvd  
Site Code : 13015-12  
Start Date : 1/8/2013  
Page No : 4

Start Time	US 41 Southbound					CAUSEWAY BLVD Westbound					US 41 Northbound					CAUSEWAY BLVD Eastbound					Int. Total
	Left	Thru	Right	U-Turns	App. Total	Left	Thru	Right	U-Turns	App. Total	Left	Thru	Right	U-Turns	App. Total	Left	Thru	Right	U-Turns	App. Total	

Peak Hour Analysis From 12:00 PM to 05:45 PM - Peak 1 of 1

Peak Hour for Entire Intersection Begins at 05:00 PM

05:00 PM	66	190	7	0	263	12	95	35	1	143	127	99	28	0	254	14	223	322	0	559	1219
05:15 PM	54	240	4	0	298	19	83	27	0	129	97	99	25	0	221	22	181	306	0	509	1157
05:30 PM	48	186	4	0	238	8	95	44	0	147	102	101	22	0	225	13	222	313	0	548	1158
05:45 PM	53	181	3	0	237	11	70	24	0	105	102	100	9	0	211	9	173	335	0	517	1070
Total Volume	221	797	18	0	1036	50	343	130	1	524	428	399	84	0	911	58	799	1276	0	2133	4604
% App. Total	21.3	76.9	1.7	0		9.5	65.5	24.8	0.2		47	43.8	9.2	0		2.7	37.5	59.8	0		
PHF	.837	.830	.643	.000	.869	.658	.903	.739	.250	.891	.843	.988	.750	.000	.897	.659	.896	.952	.000	.954	.944
Automobiles	216	766	15	0	997	47	326	117	1	491	407	361	78	0	846	49	770	1238	0	2057	4391
% Automobiles	97.7	96.1	83.3	0	96.2	94.0	95.0	90.0	100	93.7	95.1	90.5	92.9	0	92.9	84.5	96.4	97.0	0	96.4	95.4
Trucks	5	31	3	0	39	3	16	13	0	32	21	37	6	0	64	9	27	37	0	73	208
% Trucks	2.3	3.9	16.7	0	3.8	6.0	4.7	10.0	0	6.1	4.9	9.3	7.1	0	7.0	15.5	3.4	2.9	0	3.4	4.5
Buses	0	0	0	0	0	0	1	0	0	1	0	1	0	0	1	0	2	1	0	3	5
% Buses	0	0	0	0	0	0	0.3	0	0	0.2	0	0.3	0	0	0.1	0	0.3	0.1	0	0.1	0.1

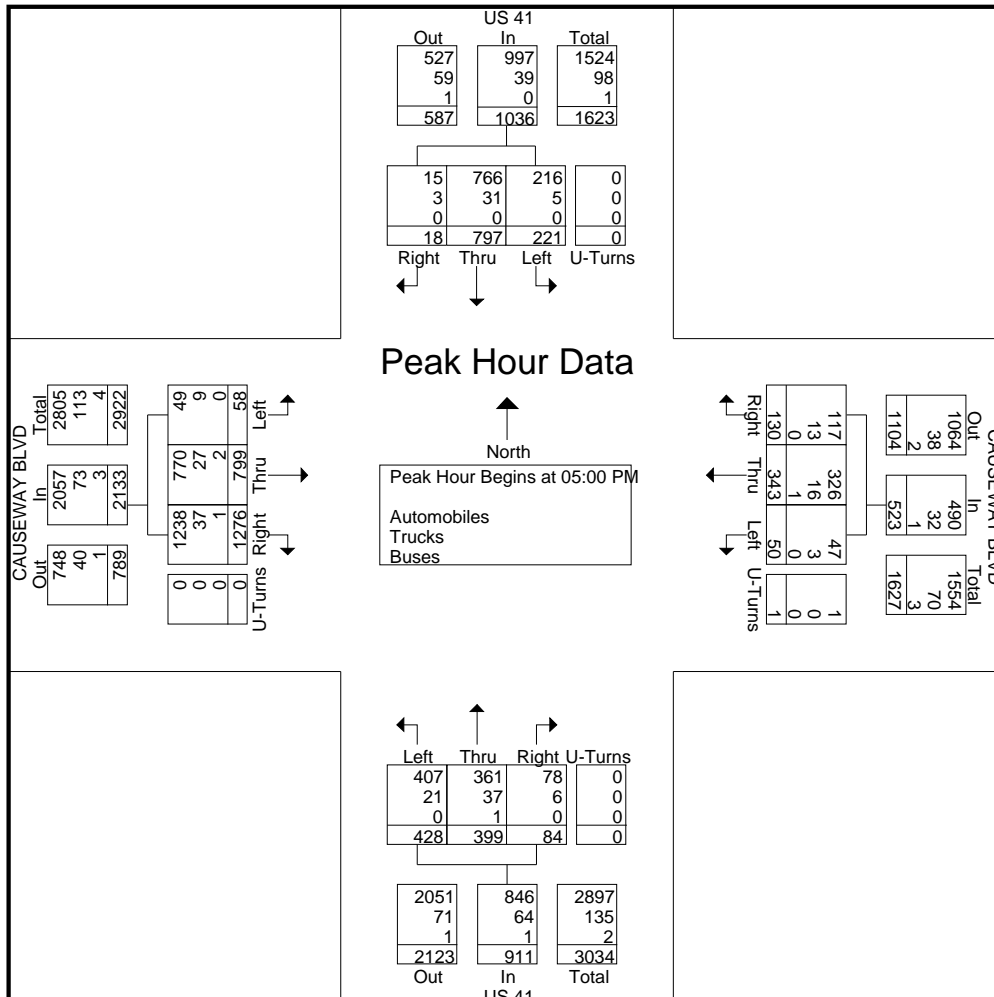



# Southern Traffic Services, Inc.

2911 Westfield Rd  
 Gulf Breeze, FL 32563  
 1-800-786-3374

*Traffic is our only business!*

US 41 @ Causeway Blvd  
 Tampa, FL

File Name : 13015-12 US 41 @ Causeway Blvd  
 Site Code : 13015-12  
 Start Date : 1/8/2013  
 Page No : 1

Groups Printed- Automobiles

Start Time	US 41 Southbound				CAUSEWAY BLVD Westbound				US 41 Northbound				CAUSEWAY BLVD Eastbound				Int. Total
	Left	Thru	Right	U-Turns	Left	Thru	Right	U-Turns	Left	Thru	Right	U-Turns	Left	Thru	Right	U-Turns	
07:00 AM	16	46	11	0	10	241	38	0	367	218	13	0	7	48	63	0	1078
07:15 AM	21	67	12	0	11	203	59	0	352	213	10	0	9	61	76	0	1094
07:30 AM	24	59	8	0	10	249	40	0	298	158	8	0	10	73	50	0	987
07:45 AM	24	75	9	0	17	165	46	0	331	210	14	0	8	67	80	0	1046
<b>Total</b>	<b>85</b>	<b>247</b>	<b>40</b>	<b>0</b>	<b>48</b>	<b>858</b>	<b>183</b>	<b>0</b>	<b>1348</b>	<b>799</b>	<b>45</b>	<b>0</b>	<b>34</b>	<b>249</b>	<b>269</b>	<b>0</b>	<b>4205</b>
08:00 AM	28	58	10	0	13	182	38	1	233	119	11	0	7	81	80	0	861
08:15 AM	14	73	6	0	11	163	47	0	192	113	14	0	13	75	65	0	786
08:30 AM	30	64	8	0	8	128	27	0	184	120	10	0	2	40	50	1	672
08:45 AM	20	50	4	0	19	105	36	0	121	85	10	1	4	69	54	0	578
<b>Total</b>	<b>92</b>	<b>245</b>	<b>28</b>	<b>0</b>	<b>51</b>	<b>578</b>	<b>148</b>	<b>1</b>	<b>730</b>	<b>437</b>	<b>45</b>	<b>1</b>	<b>26</b>	<b>265</b>	<b>249</b>	<b>1</b>	<b>2897</b>
<b>**BREAK**</b>																	
04:00 PM	42	137	7	0	8	80	31	1	98	104	25	0	20	136	173	0	862
04:15 PM	31	144	6	0	14	84	32	1	83	92	19	0	19	165	226	0	916
04:30 PM	44	163	6	0	12	76	26	0	115	74	17	0	12	140	237	0	922
04:45 PM	55	169	3	0	12	62	39	0	78	85	25	0	9	184	264	0	985
<b>Total</b>	<b>172</b>	<b>613</b>	<b>22</b>	<b>0</b>	<b>46</b>	<b>302</b>	<b>128</b>	<b>2</b>	<b>374</b>	<b>355</b>	<b>86</b>	<b>0</b>	<b>60</b>	<b>625</b>	<b>900</b>	<b>0</b>	<b>3685</b>
05:00 PM	63	177	5	0	10	93	32	1	116	91	26	0	11	215	306	0	1146
05:15 PM	54	232	4	0	19	78	26	0	96	88	23	0	19	174	299	0	1112
05:30 PM	46	179	4	0	8	87	37	0	98	91	21	0	12	216	306	0	1105
05:45 PM	53	178	2	0	10	68	22	0	97	91	8	0	7	165	327	0	1028
<b>Total</b>	<b>216</b>	<b>766</b>	<b>15</b>	<b>0</b>	<b>47</b>	<b>326</b>	<b>117</b>	<b>1</b>	<b>407</b>	<b>361</b>	<b>78</b>	<b>0</b>	<b>49</b>	<b>770</b>	<b>1238</b>	<b>0</b>	<b>4391</b>
<b>Grand Total</b>	<b>565</b>	<b>1871</b>	<b>105</b>	<b>0</b>	<b>192</b>	<b>2064</b>	<b>576</b>	<b>4</b>	<b>2859</b>	<b>1952</b>	<b>254</b>	<b>1</b>	<b>169</b>	<b>1909</b>	<b>2656</b>	<b>1</b>	<b>15178</b>
Apprch %	22.2	73.6	4.1	0	6.8	72.8	20.3	0.1	56.4	38.5	5	0	3.6	40.3	56.1	0	
Total %	3.7	12.3	0.7	0	1.3	13.6	3.8	0	18.8	12.9	1.7	0	1.1	12.6	17.5	0	



# Southern Traffic Services, Inc.

2911 Westfield Rd  
Gulf Breeze, FL 32563  
1-800-786-3374

*Traffic is our only business!*

US 41 @ Causeway Blvd  
Tampa, FL

File Name : 13015-12 US 41 @ Causeway Blvd  
Site Code : 13015-12  
Start Date : 1/8/2013  
Page No : 2

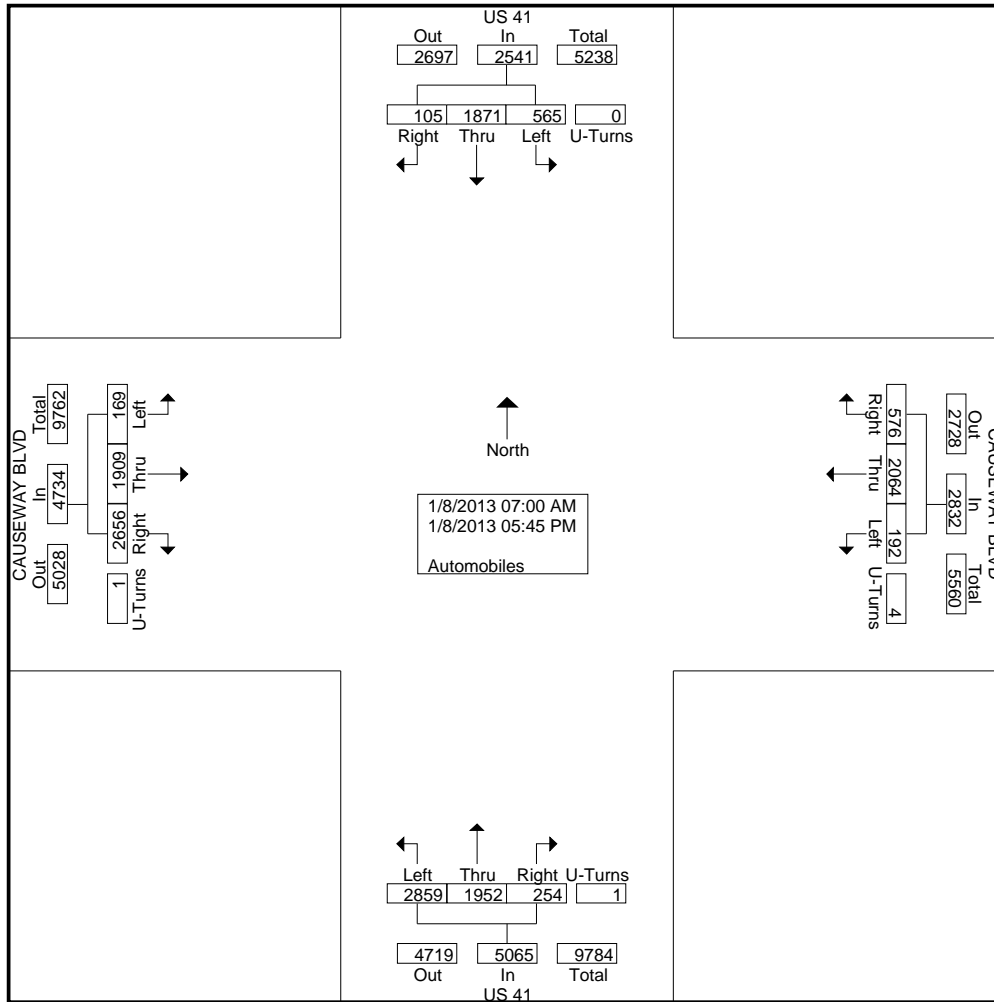



# Southern Traffic Services, Inc.

2911 Westfield Rd  
Gulf Breeze, FL 32563  
1-800-786-3374

*Traffic is our only business!*

US 41 @ Causeway Blvd  
Tampa, FL

File Name : 13015-12 US 41 @ Causeway Blvd  
Site Code : 13015-12  
Start Date : 1/8/2013  
Page No : 3

Start Time	US 41 Southbound				CAUSEWAY BLVD Westbound				US 41 Northbound				CAUSEWAY BLVD Eastbound				Int. Total				
	Thru	Right	U-Turns	App. Total	Left	Thru	Right	U-Turns	App. Total	Left	Thru	Right	U-Turns	App. Total	Left	Thru		Right	U-Turns	App. Total	
Peak Hour Analysis From 07:00 AM to 11:45 AM - Peak 1 of 1																					
Peak Hour for Entire Intersection Begins at 07:00 AM																					
07:00 AM	16	46	11	0	73	10	241	38	0	289	367	218	13	0	598	7	48	63	0	118	1078
07:15 AM	21	67	12	0	100	11	203	59	0	273	352	213	10	0	575	9	61	76	0	146	1094
07:30 AM	24	59	8	0	91	10	249	40	0	299	298	158	8	0	464	10	73	50	0	133	987
07:45 AM	24	75	9	0	108	17	165	46	0	228	331	210	14	0	555	8	67	80	0	155	1046
Total Volume	85	247	40	0	372	48	858	183	0	1089	1348	799	45	0	2192	34	249	269	0	552	4205
% App. Total	22.8	66.4	10.8	0		4.4	78.8	16.8	0		61.5	36.5	2.1	0		6.2	45.1	48.7	0		
PHF	.885	.823	.833	.000	.861	.706	.861	.775	.000	.911	.918	.916	.804	.000	.916	.850	.853	.841	.000	.890	.961

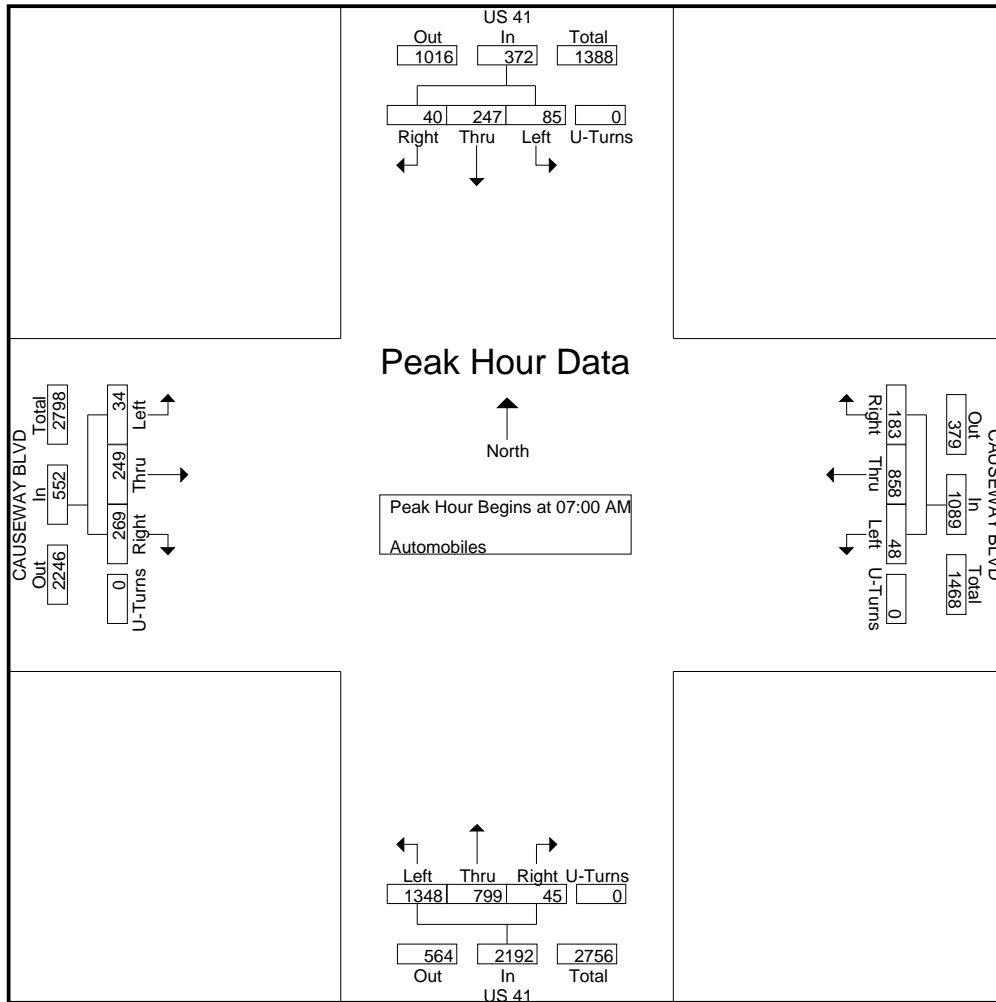



# Southern Traffic Services, Inc.

2911 Westfield Rd  
Gulf Breeze, FL 32563  
1-800-786-3374

*Traffic is our only business!*

US 41 @ Causeway Blvd  
Tampa, FL

File Name : 13015-12 US 41 @ Causeway Blvd  
Site Code : 13015-12  
Start Date : 1/8/2013  
Page No : 4

Start Time	US 41 Southbound					CAUSEWAY BLVD Westbound					US 41 Northbound					CAUSEWAY BLVD Eastbound					Int. Total
	Left	Thru	Right	U-Turns	App. Total	Left	Thru	Right	U-Turns	App. Total	Left	Thru	Right	U-Turns	App. Total	Left	Thru	Right	U-Turns	App. Total	
Peak Hour Analysis From 12:00 PM to 05:45 PM - Peak 1 of 1																					
Peak Hour for Entire Intersection Begins at 05:00 PM																					
05:00 PM	63	177	5	0	245	10	93	32	1	136	116	91	26	0	233	11	215	306	0	532	1146
05:15 PM	54	232	4	0	290	19	78	26	0	123	96	88	23	0	207	19	174	299	0	492	1112
05:30 PM	46	179	4	0	229	8	87	37	0	132	98	91	21	0	210	12	216	306	0	534	1105
05:45 PM	53	178	2	0	233	10	68	22	0	100	97	91	8	0	196	7	165	327	0	499	1028
Total Volume	216	766	15	0	997	47	326	117	1	491	407	361	78	0	846	49	770	1238	0	2057	4391
% App. Total	21.7	76.8	1.5	0		9.6	66.4	23.8	0.2		48.1	42.7	9.2	0		2.4	37.4	60.2	0		
PHF	.857	.825	.750	.000	.859	.618	.876	.791	.250	.903	.877	.992	.750	.000	.908	.645	.891	.946	.000	.963	.958

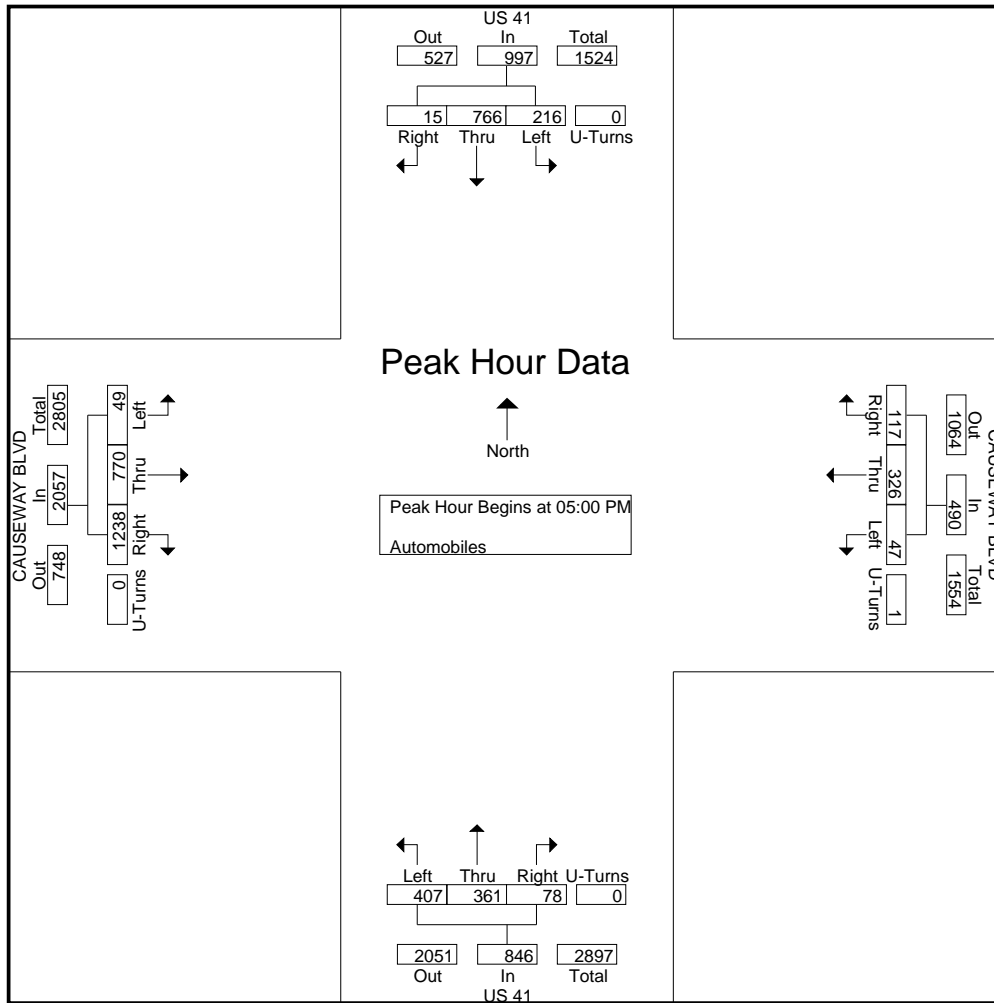



# Southern Traffic Services, Inc.

2911 Westfield Rd  
Gulf Breeze, FL 32563  
1-800-786-3374

*Traffic is our only business!*

US 41 @ Causeway Blvd  
Tampa, FL

File Name : 13015-12 US 41 @ Causeway Blvd  
Site Code : 13015-12  
Start Date : 1/8/2013  
Page No : 1

Groups Printed- Trucks - Buses

Start Time	US 41 Southbound				CAUSEWAY BLVD Westbound				US 41 Northbound				CAUSEWAY BLVD Eastbound				Int. Total
	Left	Thru	Right	U-Turns	Left	Thru	Right	U-Turns	Left	Thru	Right	U-Turns	Left	Thru	Right	U-Turns	
07:00 AM	6	15	2	0	1	8	2	0	13	19	0	0	1	15	17	0	99
07:15 AM	5	21	4	0	1	7	4	0	10	20	2	0	2	7	13	0	96
07:30 AM	2	16	2	0	1	10	4	0	11	15	2	0	1	17	9	0	90
07:45 AM	2	15	2	0	0	18	5	0	19	14	2	0	8	7	15	0	107
Total	15	67	10	0	3	43	15	0	53	68	6	0	12	46	54	0	392
08:00 AM	1	20	4	0	2	10	3	0	13	19	5	0	2	6	16	0	101
08:15 AM	0	19	5	0	1	7	2	0	19	20	2	0	3	8	13	0	99
08:30 AM	4	17	3	0	1	9	3	0	19	10	5	0	4	12	11	0	98
08:45 AM	4	14	4	0	4	10	3	0	16	21	1	0	9	10	16	0	112
Total	9	70	16	0	8	36	11	0	67	70	13	0	18	36	56	0	410
<b>**BREAK**</b>																	
04:00 PM	3	16	3	0	4	14	4	0	7	13	2	0	4	10	13	0	93
04:15 PM	1	21	2	0	2	12	7	0	4	13	2	0	3	17	12	0	96
04:30 PM	6	10	4	0	3	8	3	0	5	20	4	0	5	10	11	0	89
04:45 PM	0	12	1	0	3	8	2	0	6	12	3	0	3	11	12	0	73
Total	10	59	10	0	12	42	16	0	22	58	11	0	15	48	48	0	351
05:00 PM	3	13	2	0	2	2	3	0	11	8	2	0	3	8	16	0	73
05:15 PM	0	8	0	0	0	5	1	0	1	11	2	0	3	7	7	0	45
05:30 PM	2	7	0	0	0	8	7	0	4	10	1	0	1	6	7	0	53
05:45 PM	0	3	1	0	1	2	2	0	5	9	1	0	2	8	8	0	42
Total	5	31	3	0	3	17	13	0	21	38	6	0	9	29	38	0	213
Grand Total	39	227	39	0	26	138	55	0	163	234	36	0	54	159	196	0	1366
Apprch %	12.8	74.4	12.8	0	11.9	63	25.1	0	37.6	54	8.3	0	13.2	38.9	47.9	0	
Total %	2.9	16.6	2.9	0	1.9	10.1	4	0	11.9	17.1	2.6	0	4	11.6	14.3	0	
Trucks	35	225	36	0	26	132	47	0	163	233	36	0	53	145	192	0	1323
% Trucks	89.7	99.1	92.3	0	100	95.7	85.5	0	100	99.6	100	0	98.1	91.2	98	0	96.9
Buses	4	2	3	0	0	6	8	0	0	1	0	0	1	14	4	0	43
% Buses	10.3	0.9	7.7	0	0	4.3	14.5	0	0	0.4	0	0	1.9	8.8	2	0	3.1





# Southern Traffic Services, Inc.

2911 Westfield Rd  
 Gulf Breeze, FL 32563  
 1-800-786-3374

*Traffic is our only business!*

US 41 @ Causeway Blvd  
 Tampa, FL

File Name : 13015-12 US 41 @ Causeway Blvd  
 Site Code : 13015-12  
 Start Date : 1/8/2013  
 Page No : 2

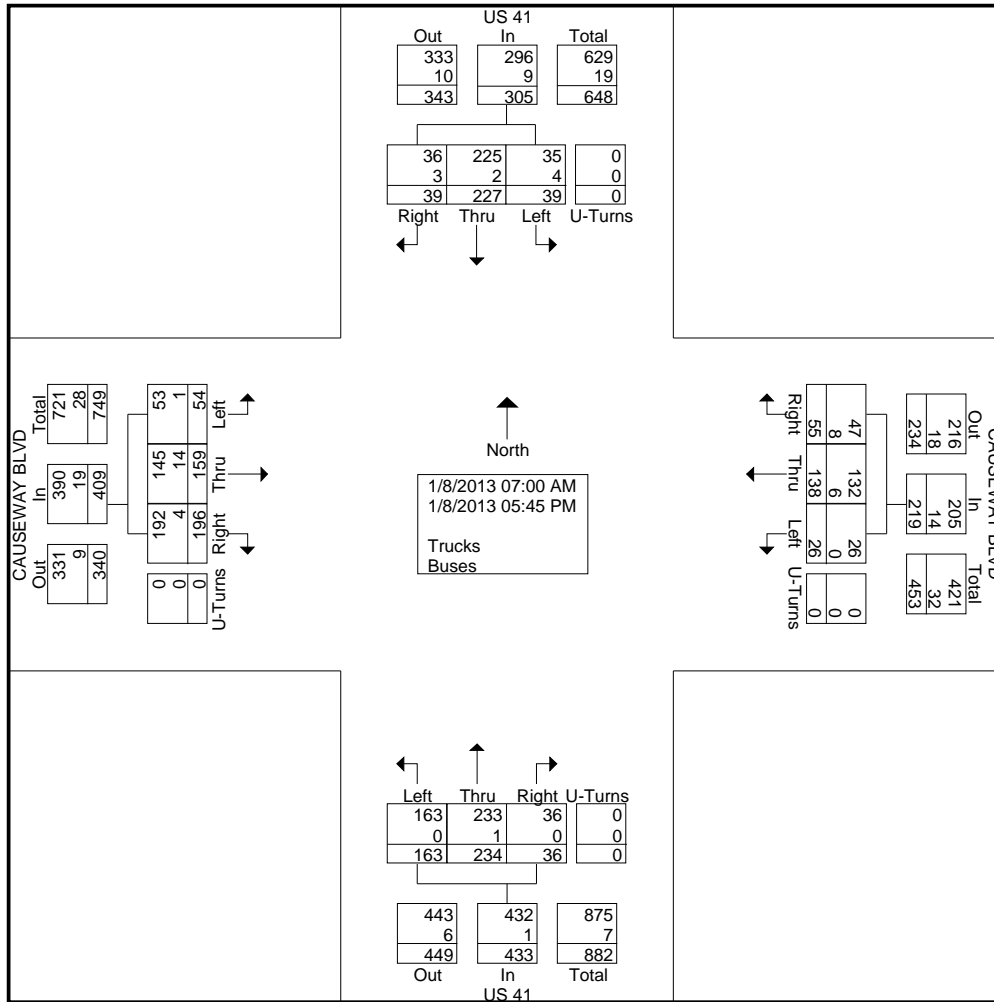



# Southern Traffic Services, Inc.

2911 Westfield Rd  
Gulf Breeze, FL 32563  
1-800-786-3374

*Traffic is our only business!*

US 41 @ Causeway Blvd  
Tampa, FL

File Name : 13015-12 US 41 @ Causeway Blvd  
Site Code : 13015-12  
Start Date : 1/8/2013  
Page No : 3

Start Time	US 41 Southbound				CAUSEWAY BLVD Westbound				US 41 Northbound				CAUSEWAY BLVD Eastbound				Int. Total				
	Thru	Right	U-Turns	App. Total	Left	Thru	Right	U-Turns	App. Total	Left	Thru	Right	U-Turns	App. Total	Left	Thru		Right	U-Turns	App. Total	
Peak Hour Analysis From 07:00 AM to 11:45 AM - Peak 1 of 1																					
Peak Hour for Entire Intersection Begins at 08:00 AM																					
08:00 AM	1	20	4	0	25	2	10	3	0	15	13	19	5	0	37	2	6	16	0	24	101
08:15 AM	0	19	5	0	24	1	7	2	0	10	19	20	2	0	41	3	8	13	0	24	99
08:30 AM	4	17	3	0	24	1	9	3	0	13	19	10	5	0	34	4	12	11	0	27	98
08:45 AM	4	14	4	0	22	4	10	3	0	17	16	21	1	0	38	9	10	16	0	35	112
Total Volume	9	70	16	0	95	8	36	11	0	55	67	70	13	0	150	18	36	56	0	110	410
% App. Total	9.5	73.7	16.8	0		14.5	65.5	20	0		44.7	46.7	8.7	0		16.4	32.7	50.9	0		
PHF	.563	.875	.800	.000	.950	.500	.900	.917	.000	.809	.882	.833	.650	.000	.915	.500	.750	.875	.000	.786	.915

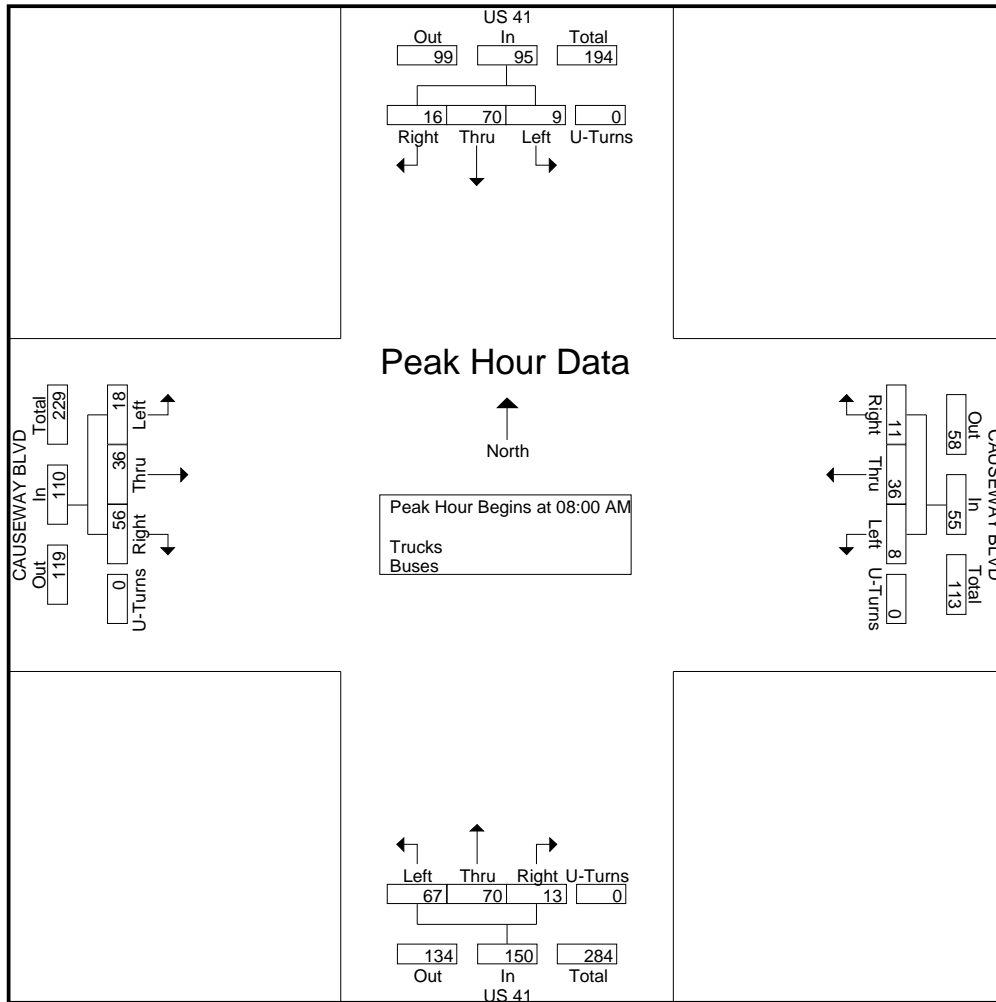



# Southern Traffic Services, Inc.

2911 Westfield Rd  
Gulf Breeze, FL 32563  
1-800-786-3374

*Traffic is our only business!*

US 41 @ Causeway Blvd  
Tampa, FL

File Name : 13015-12 US 41 @ Causeway Blvd  
Site Code : 13015-12  
Start Date : 1/8/2013  
Page No : 4

Start Time	US 41 Southbound					CAUSEWAY BLVD Westbound					US 41 Northbound					CAUSEWAY BLVD Eastbound					Int. Total
	Left	Thru	Right	U-Turns	App. Total	Left	Thru	Right	U-Turns	App. Total	Left	Thru	Right	U-Turns	App. Total	Left	Thru	Right	U-Turns	App. Total	
Peak Hour Analysis From 12:00 PM to 05:45 PM - Peak 1 of 1																					
Peak Hour for Entire Intersection Begins at 04:00 PM																					
04:00 PM	3	16	3	0	22	4	14	4	0	22	7	13	2	0	22	4	10	13	0	27	93
04:15 PM	1	21	2	0	24	2	12	7	0	21	4	13	2	0	19	3	17	12	0	32	96
04:30 PM	6	10	4	0	20	3	8	3	0	14	5	20	4	0	29	5	10	11	0	26	89
04:45 PM	0	12	1	0	13	3	8	2	0	13	6	12	3	0	21	3	11	12	0	26	73
Total Volume	10	59	10	0	79	12	42	16	0	70	22	58	11	0	91	15	48	48	0	111	351
% App. Total	12.7	74.7	12.7	0		17.1	60	22.9	0		24.2	63.7	12.1	0		13.5	43.2	43.2	0		
PHF	.417	.702	.625	.000	.823	.750	.750	.571	.000	.795	.786	.725	.688	.000	.784	.750	.706	.923	.000	.867	.914

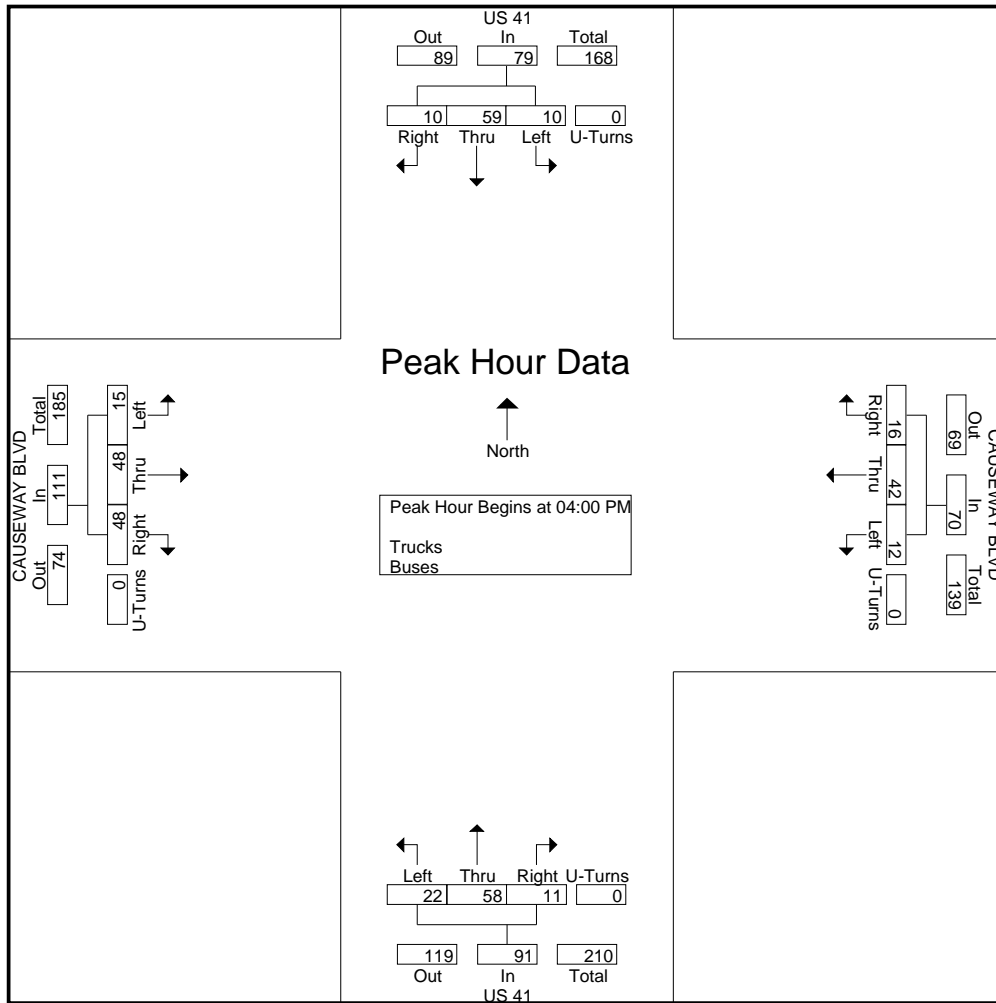



# Southern Traffic Services, Inc.

2911 Westfield Rd  
 Gulf Breeze, FL 32563  
 1-800-786-3374

*Traffic is our only business!*

US 41 @ Causeway Blvd  
 Tampa, FL

File Name : 13015-12 US 41 @ Causeway Blvd Peds  
 Site Code : 13015-12  
 Start Date : 1/8/2013  
 Page No : 1

Groups Printed- Peds

Start Time	US 41	CAUSEWAY BLVD	US 41	CAUSEWAY BLVD	Int. Total
	Southbound	Westbound	Northbound	Eastbound	
	Peds	Peds	Peds	Peds	
07:00 AM	0	0	0	0	0
07:15 AM	1	0	0	0	1
07:30 AM	0	0	0	0	0
07:45 AM	0	1	0	0	1
Total	1	1	0	0	2
08:00 AM	1	1	0	1	3
08:15 AM	0	1	0	0	1
08:30 AM	0	0	0	0	0
08:45 AM	0	0	0	0	0
Total	1	2	0	1	4
09:00 AM	0	0	0	0	0
09:15 AM	0	0	0	0	0
09:30 AM	0	0	0	0	0
09:45 AM	0	0	0	0	0
Total	0	0	0	0	0
10:00 AM	0	0	0	0	0
10:15 AM	0	0	0	0	0
10:30 AM	0	0	0	0	0
10:45 AM	0	0	0	0	0
Total	0	0	0	0	0
11:00 AM	0	0	0	0	0
11:15 AM	0	0	0	0	0
11:30 AM	0	0	0	0	0
11:45 AM	0	0	0	0	0
Total	0	0	0	0	0
12:00 PM	0	0	0	0	0
12:15 PM	0	0	0	0	0
12:30 PM	0	0	0	0	0
12:45 PM	0	0	0	0	0
Total	0	0	0	0	0
01:00 PM	0	0	0	0	0
01:15 PM	0	0	0	0	0
01:30 PM	0	0	0	0	0
01:45 PM	0	0	0	0	0
Total	0	0	0	0	0
02:00 PM	0	0	0	0	0
02:15 PM	0	0	0	0	0
02:30 PM	0	0	0	0	0
02:45 PM	0	0	0	0	0
Total	0	0	0	0	0
03:00 PM	0	0	0	0	0
03:15 PM	0	0	0	0	0
03:30 PM	0	0	0	0	0
03:45 PM	0	0	0	0	0
Total	0	0	0	0	0



# Southern Traffic Services, Inc.

2911 Westfield Rd  
 Gulf Breeze, FL 32563  
 1-800-786-3374

*Traffic is our only business!*

US 41 @ Causeway Blvd  
 Tampa, FL

File Name : 13015-12 US 41 @ Causeway Blvd Peds  
 Site Code : 13015-12  
 Start Date : 1/8/2013  
 Page No : 2

Groups Printed- Peds

	US 41 Southbound	CAUSEWAY BLVD Westbound	US 41 Northbound	CAUSEWAY BLVD Eastbound	Int. Total
	Peds	Peds	Peds	Peds	
Start Time					
04:00 PM	0	1	1	1	3
04:15 PM	0	0	0	2	2
04:30 PM	0	0	0	1	1
04:45 PM	0	0	0	1	1
Total	0	1	1	5	7
05:00 PM	0	0	0	0	0
05:15 PM	0	0	0	3	3
05:30 PM	1	0	0	0	1
05:45 PM	1	0	0	0	1
Total	2	0	0	3	5
Grand Total	4	4	1	9	18
Apprch %	100	100	100	100	
Total %	22.2	22.2	5.6	50	

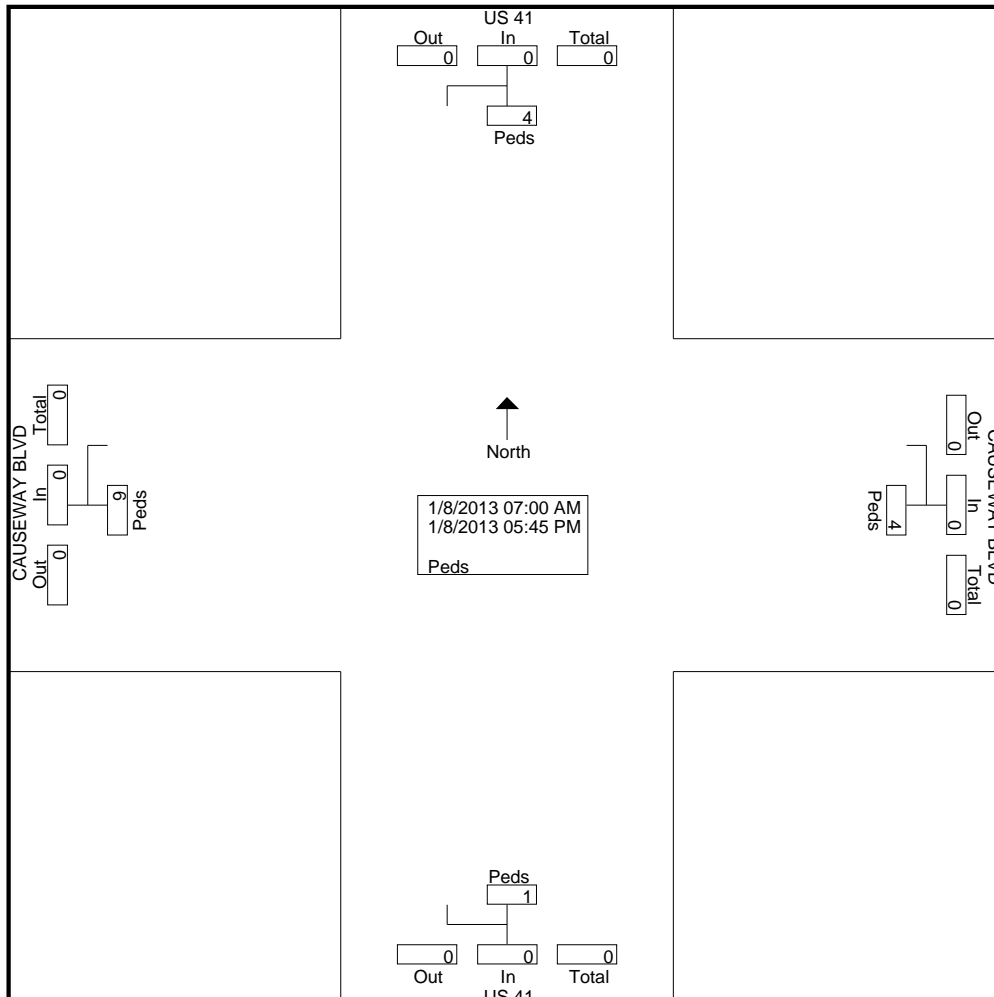

# Southern Traffic Services, Inc.

## Event Counts

**US 41 north of Causeway Blvd**

**Northbound**

**Datasets:**

**Site:** [121] I5136  
**Input A:** 1 - North bound, A hit first. - Added to totals. (1)  
**Input B:** 0 - Unused or unknown. - Excluded from totals. (0)  
**Survey Duration:** 17:21 Monday, January 14, 2013 => 14:58 Friday, January 18, 2013  
**File:** G:\DATA\2013\Private\13015\resets\UM121 NB.eco (Plus)  
**Identifier:** Q3051BN0 MC56-L5 [MC55] (c)Microcom 19Oct04  
**Algorithm:** Event Count  
**Data type:** Axle sensors - Paired (Class, Speed, Count)

**Profile:**

**Filter time:** 0:00 Tuesday, January 15, 2013 => 0:00 Friday, January 18, 2013  
**Name:** Factory default profile  
**Scheme:** Count events divided by two.  
**Units:** Non metric (ft, mi, ft/s, mph, lb, ton)  
**In profile:** Events = 37553

**Tuesday, January 15, 2013=12251, 15 minute drops**

0000	0100	0200	0300	0400	0500	0600	0700	0800	0900	1000	1100	1200	1300	1400	1500	1600	1700	1800	1900	2000	2100	2200	2300	
71	70	89	115	241	408	817	1245	944	724	716	738	766	807	873	815	693	676	474	331	228	168	130	112	
8	16	31	24	33	59	118	282	155	157	190	183	218	194	218	215	193	173	146	117	55	43	39	37	22
18	22	14	20	78	97	208	293	359	192	177	170	176	214	150	207	162	210	114	76	59	45	39	24	11
22	12	22	45	45	71	252	327	228	185	171	173	147	201	256	202	168	153	118	70	70	45	28	32	26
23	20	22	26	85	181	239	343	202	190	178	212	225	198	249	191	170	140	96	68	44	35	24	19	26

AM Peak 0700 - 0800 (1245), AM PHF=0.91 PM Peak 1430 - 1530 (927), PM PHF=0.91

**Wednesday, January 16, 2013=12400, 15 minute drops**

0000	0100	0200	0300	0400	0500	0600	0700	0800	0900	1000	1100	1200	1300	1400	1500	1600	1700	1800	1900	2000	2100	2200	2300	
85	83	67	98	180	381	816	1276	998	646	872	739	743	717	833	936	802	590	527	301	258	166	172	114	
22	27	9	25	38	51	141	220	298	165	280	156	187	180	201	211	194	185	165	92	79	49	63	25	29
11	19	21	21	52	90	174	362	225	194	228	192	178	171	211	262	243	165	120	77	67	51	41	34	26
26	15	18	29	55	113	244	358	255	154	157	213	173	173	197	227	191	131	133	54	53	19	47	39	24
26	22	19	23	35	127	257	336	220	133	207	178	205	193	224	236	174	109	109	78	59	47	21	16	31

AM Peak 0715 - 0815 (1354), AM PHF=0.94 PM Peak 1500 - 1600 (936), PM PHF=0.89

**Thursday, January 17, 2013=12902, 15 minute drops**

0000	0100	0200	0300	0400	0500	0600	0700	0800	0900	1000	1100	1200	1300	1400	1500	1600	1700	1800	1900	2000	2100	2200	2300	
110	63	91	115	238	460	757	1226	1032	794	823	812	738	844	814	950	847	641	477	350	287	168	146	119	
29	26	25	27	39	88	120	320	290	195	182	160	206	204	204	234	206	172	140	106	71	35	47	30	15
26	16	21	22	58	93	132	254	282	189	169	238	196	207	245	213	231	180	149	92	83	40	38	45	29
24	15	20	21	67	117	207	297	251	210	281	227	141	243	170	285	212	150	101	86	81	49	33	31	18
31	6	25	45	74	162	298	355	209	200	191	187	195	190	195	218	198	139	87	66	52	44	28	13	15

AM Peak 0700 - 0800 (1226), AM PHF=0.86 PM Peak 1500 - 1600 (950), PM PHF=0.83

# Southern Traffic Services, Inc.

## Event Counts

**US 41 north of Causeway Blvd**

**Southbound**

**Datasets:**

**Site:** [121] I9029  
**Input A:** 3 - South bound, A hit first. - Added to totals. (1)  
**Input B:** 0 - Unused or unknown. - Excluded from totals. (0)  
**Survey Duration:** 17:16 Monday, January 14, 2013 => 14:53 Friday, January 18, 2013  
**File:** G:\DATA\2013\Private\13015\resets\UM121 SB.eco (Plus)  
**Identifier:** AQ892A50 MC56-L5 [MC55] (c)Microcom 19Oct04  
**Algorithm:** Event Count  
**Data type:** Axle sensors - Paired (Class, Speed, Count)

**Profile:**

**Filter time:** 0:00 Tuesday, January 15, 2013 => 0:00 Friday, January 18, 2013  
**Name:** Factory default profile  
**Scheme:** Count events divided by two.  
**Units:** Non metric (ft, mi, ft/s, mph, lb, ton)  
**In profile:** Events = 35717

**Tuesday, January 15, 2013=11829, 15 minute drops**

0000	0100	0200	0300	0400	0500	0600	0700	0800	0900	1000	1100	1200	1300	1400	1500	1600	1700	1800	1900	2000	2100	2200	2300	
77	94	73	105	166	299	553	604	645	694	569	608	739	715	810	861	1021	1076	720	431	343	279	207	140	
15	19	19	19	21	42	98	154	167	180	126	138	199	196	210	195	250	307	182	116	98	78	61	46	18
23	19	13	34	37	68	129	141	154	169	143	166	176	182	165	240	215	271	202	96	71	58	58	29	19
17	37	20	25	47	83	194	146	158	175	154	145	197	161	232	180	274	255	169	111	99	64	54	28	18
22	19	21	27	61	106	132	163	166	170	146	159	167	176	203	246	282	243	167	108	75	79	34	37	16

AM Peak 1145 - 1245 (731), AM PHF=0.92 PM Peak 1630 - 1730 (1134), PM PHF=0.92

**Wednesday, January 16, 2013=12091, 15 minute drops**

0000	0100	0200	0300	0400	0500	0600	0700	0800	0900	1000	1100	1200	1300	1400	1500	1600	1700	1800	1900	2000	2100	2200	2300	
71	102	78	107	181	377	568	640	656	589	634	621	751	752	806	881	902	1062	931	469	349	262	183	119	
18	18	19	20	31	48	138	130	142	122	169	170	178	182	203	216	214	305	290	128	78	65	48	35	23
19	28	21	29	44	95	110	104	179	155	150	133	186	200	226	196	182	277	236	144	86	70	52	31	24
18	33	18	31	47	120	159	219	168	165	158	153	197	196	174	233	270	270	200	105	85	69	55	27	23
16	23	20	27	59	114	161	187	167	147	157	165	190	174	203	236	236	210	205	92	100	58	28	26	28

AM Peak 0730 - 0830 (727), AM PHF=0.83 PM Peak 1630 - 1730 (1088), PM PHF=0.89

**Thursday, January 17, 2013=11797, 15 minute drops**

0000	0100	0200	0300	0400	0500	0600	0700	0800	0900	1000	1100	1200	1300	1400	1500	1600	1700	1800	1900	2000	2100	2200	2300	
98	96	85	117	173	348	516	517	712	572	626	615	725	783	796	880	927	1051	760	456	318	319	202	105	
23	20	15	21	24	56	111	139	199	161	153	144	163	180	198	184	231	270	253	120	78	67	49	37	31
24	27	28	21	40	61	112	148	189	134	164	144	185	196	200	219	236	285	202	127	93	96	62	27	23
23	25	22	50	47	100	155	96	154	132	163	162	198	202	201	206	240	246	174	111	81	87	53	16	22
28	24	20	25	62	131	138	134	170	145	146	165	179	205	197	271	220	250	131	98	66	69	38	25	16

AM Peak 0800 - 0900 (712), AM PHF=0.89 PM Peak 1700 - 1800 (1051), PM PHF=0.92

# Southern Traffic Services, Inc.

## Event Counts

**US 41 south of Causeway Blvd**

**Northbound**

**Datasets:**

**Site:** [122] !8001  
**Input A:** 1 - North bound, A hit first. - Added to totals. (1)  
**Input B:** 0 - Unused or unknown. - Excluded from totals. (0)  
**Survey Duration:** 6:55 Monday, January 07, 2013 => 11:41 Friday, January 11, 2013  
**File:** G:\DATA\2013\Private\13015\diego\Data 1-7-13\UM122 NB.eco (Plus)  
**Identifier:** W66559ZK MC56-L5 [MC55] (c)Microcom 19Oct04  
**Algorithm:** Event Count  
**Data type:** Axle sensors - Paired (Class, Speed, Count)

**Profile:**

**Filter time:** 0:00 Tuesday, January 08, 2013 => 0:00 Friday, January 11, 2013  
**Name:** Factory default profile  
**Scheme:** Count events divided by two.  
**Units:** Non metric (ft, mi, ft/s, mph, lb, ton)  
**In profile:** Events = 54285

**Tuesday, January 08, 2013=17706, 15 minute drops**

0000	0100	0200	0300	0400	0500	0600	0700	0800	0900	1000	1100	1200	1300	1400	1500	1600	1700	1800	1900	2000	2100	2200	2300	
70	71	71	161	284	681	1445	2369	1551	1009	973	934	991	1119	853	1348	999	974	686	372	237	224	175	109	
23	20	17	27	52	127	288	687	485	280	261	223	267	261	203	505	272	311	198	112	54	47	52	33	27
14	18	19	25	53	159	390	582	385	272	251	229	235	204	301	242	248	224	214	97	53	50	53	22	21
15	15	23	54	74	181	247	573	371	230	193	245	235	291	248	378	254	235	157	101	73	67	40	34	24
18	18	12	55	105	214	520	527	310	227	268	237	254	363	101	223	225	204	117	62	57	60	30	20	21

AM Peak 0700 - 0800 (2369), AM PHF=0.86 PM Peak 1500 - 1600 (1348), PM PHF=0.67

**Wednesday, January 09, 2013=18215, 15 minute drops**

0000	0100	0200	0300	0400	0500	0600	0700	0800	0900	1000	1100	1200	1300	1400	1500	1600	1700	1800	1900	2000	2100	2200	2300	
93	89	96	140	328	737	1488	2583	1560	1037	999	829	1120	934	1015	1118	1066	976	716	440	233	281	213	124	
27	23	36	23	73	127	318	810	487	256	255	214	241	212	274	304	288	278	195	95	55	81	59	55	26
21	30	12	29	53	161	294	591	398	267	259	220	363	256	250	230	264	235	188	173	65	69	60	29	16
24	23	25	54	85	223	616	617	383	259	219	214	260	212	254	301	283	210	182	87	52	69	52	16	11
21	13	23	34	117	226	260	565	292	255	266	181	256	254	237	283	231	253	151	85	61	62	42	24	21

AM Peak 0700 - 0800 (2583), AM PHF=0.80 PM Peak 1530 - 1630 (1136), PM PHF=0.94

**Thursday, January 10, 2013=18364, 15 minute drops**

0000	0100	0200	0300	0400	0500	0600	0700	0800	0900	1000	1100	1200	1300	1400	1500	1600	1700	1800	1900	2000	2100	2200	2300	
74	72	82	110	287	764	1692	2332	1457	1302	927	1043	983	1076	1054	1134	1048	945	720	410	287	244	208	113	
26	29	19	15	32	145	301	502	451	527	208	272	265	270	272	274	299	261	205	138	60	73	52	17	29
16	10	18	30	66	162	381	577	478	255	257	140	215	108	252	253	269	223	219	109	81	62	61	40	20
11	20	21	34	98	227	246	631	342	266	217	357	250	429	271	340	240	235	180	87	82	61	57	32	19
21	13	24	31	91	230	764	622	186	254	245	274	253	269	259	267	240	226	116	76	64	48	38	24	13

AM Peak 0645 - 0745 (2474), AM PHF=0.81 PM Peak 1330 - 1430 (1222), PM PHF=0.71



# Southern Traffic Services, Inc.

## Event Counts

**US 41 south of Causeway Blvd**

**Southbound**

**Datasets:**

**Site:** [122] I3MM  
**Input A:** 3 - South bound, A hit first. - Added to totals. (1)  
**Input B:** 0 - Unused or unknown. - Excluded from totals. (0)  
**Survey Duration:** 7:00 Monday, January 07, 2013 => 11:44 Friday, January 11, 2013  
**File:** G:\DATA\2013\Private\13015\diego\Data 1-7-13\UM122 SB.eco (Plus)  
**Identifier:** M31226ZC MC56-6 [MC55] (c)Microcom 02/03/01  
**Algorithm:** Event Count  
**Data type:** Axle sensors - Paired (Class, Speed, Count)

**Profile:**

**Filter time:** 0:00 Tuesday, January 08, 2013 => 0:00 Friday, January 11, 2013  
**Name:** Factory default profile  
**Scheme:** Count events divided by two.  
**Units:** Non metric (ft, mi, ft/s, mph, lb, ton)  
**In profile:** Events = 57083

**Tuesday, January 08, 2013=18771, 15 minute drops**

0000	0100	0200	0300	0400	0500	0600	0700	0800	0900	1000	1100	1200	1300	1400	1500	1600	1700	1800	1900	2000	2100	2200	2300	
230	132	140	160	244	495	814	786	778	804	817	900	960	1042	984	1513	1871	2152	1482	812	597	445	343	270	
106	37	45	24	48	68	185	174	217	219	187	198	226	243	257	331	392	560	480	231	172	106	118	73	40
49	34	32	38	42	117	170	212	205	188	219	231	215	294	263	358	490	544	389	202	162	107	87	81	36
43	25	30	50	71	148	237	167	174	212	220	233	267	264	267	393	495	520	356	190	146	118	88	58	33
32	36	33	48	83	162	222	233	182	185	191	238	252	241	197	431	494	528	257	189	117	114	50	58	19

AM Peak 1145 - 1245 (946), AM PHF=0.89 PM Peak 1700 - 1800 (2152), PM PHF=0.96

**Wednesday, January 09, 2013=19161, 15 minute drops**

0000	0100	0200	0300	0400	0500	0600	0700	0800	0900	1000	1100	1200	1300	1400	1500	1600	1700	1800	1900	2000	2100	2200	2300	
128	172	124	142	261	583	833	954	855	861	820	998	944	990	1148	1417	1846	2187	1370	740	575	504	392	317	
40	53	34	38	62	80	172	246	225	226	217	234	234	216	286	285	440	578	405	213	147	138	111	86	56
36	46	34	43	69	143	198	239	199	220	189	256	219	278	257	383	458	533	394	182	169	120	112	79	50
33	48	29	25	73	175	232	247	235	211	212	262	261	259	287	331	466	537	315	190	125	136	72	74	43
19	25	27	36	57	185	231	222	196	204	202	246	230	237	318	418	482	539	256	155	134	110	97	78	46

AM Peak 1100 - 1200 (998), AM PHF=0.95 PM Peak 1700 - 1800 (2187), PM PHF=0.95

**Thursday, January 10, 2013=19151, 15 minute drops**

0000	0100	0200	0300	0400	0500	0600	0700	0800	0900	1000	1100	1200	1300	1400	1500	1600	1700	1800	1900	2000	2100	2200	2300	
195	153	138	142	256	482	874	900	830	838	833	944	1018	978	1136	1419	1871	2094	1450	791	630	453	431	295	
56	48	34	31	51	76	215	218	229	228	168	209	215	253	268	311	447	515	390	258	151	115	113	83	54
50	37	27	30	60	103	189	213	177	182	187	214	283	250	277	317	464	550	406	223	182	139	112	75	62
43	45	50	43	62	163	226	227	221	210	225	275	265	214	303	401	465	539	363	180	139	107	104	76	63
46	23	27	38	83	140	244	242	203	218	253	246	255	261	288	390	495	490	291	130	158	92	102	61	35

AM Peak 1130 - 1230 (1019), AM PHF=0.90 PM Peak 1645 - 1745 (2099), PM PHF=0.95

# Southern Traffic Services, Inc.

## Event Counts

**Causeway Blvd east of US 41**

**Eastbound**

**Datasets:**

**Site:** [123] !4467  
**Input A:** 8 - East bound A>B, West bound B>A. - Added to totals. (1)  
**Input B:** 0 - Unused or unknown. - Excluded from totals. (0)  
**Survey Duration:** 6:58 Monday, January 07, 2013 => 11:52 Friday, January 11, 2013  
**File:** G:\DATA\2013\Private\13015\diego\Data 1-7-13\UM123.eco (Plus)  
**Identifier:** P884EDXB MC56-L4 [MC55] (c)Microcom 19Sep03  
**Algorithm:** Event Count  
**Data type:** Axle sensors - Paired (Class, Speed, Count)

**Profile:**

**Filter time:** 0:00 Tuesday, January 08, 2013 => 0:00 Friday, January 11, 2013  
**Name:** Factory default profile  
**Scheme:** Count events divided by two.  
**Units:** Non metric (ft, mi, ft/s, mph, lb, ton)  
**In profile:** Events = 34664

**Tuesday, January 08, 2013=11502, 15 minute drops**

0000	0100	0200	0300	0400	0500	0600	0700	0800	0900	1000	1100	1200	1300	1400	1500	1600	1700	1800	1900	2000	2100	2200	2300	
211	107	109	103	162	226	353	499	497	509	572	598	614	591	726	880	1039	1163	784	473	396	430	252	208	
90	35	22	29	39	37	87	109	141	106	146	122	166	136	171	194	251	301	234	123	100	104	79	46	30
50	34	33	15	35	47	73	125	114	117	154	146	145	152	183	199	254	324	217	137	102	109	63	56	25
42	17	25	23	52	80	71	128	126	141	141	171	140	146	156	268	226	266	177	109	124	144	66	59	31
29	21	29	36	36	62	122	137	116	145	131	159	163	157	216	219	308	272	156	104	70	73	44	47	26

AM Peak 1115 - 1215 (642), AM PHF=0.94 PM Peak 1645 - 1745 (1199), PM PHF=0.93

**Wednesday, January 09, 2013=11624, 15 minute drops**

0000	0100	0200	0300	0400	0500	0600	0700	0800	0900	1000	1100	1200	1300	1400	1500	1600	1700	1800	1900	2000	2100	2200	2300	
112	117	82	102	147	255	362	493	535	508	547	601	598	647	693	872	1008	1126	840	544	459	382	322	272	
30	40	23	25	41	37	50	105	106	124	140	124	150	155	164	181	243	285	276	154	105	108	81	71	52
25	27	14	17	21	63	76	111	146	122	135	142	164	143	154	222	248	241	212	172	91	93	94	67	56
31	27	20	23	36	84	97	130	140	127	128	181	152	169	191	217	256	335	192	110	138	98	86	77	39
26	23	25	37	49	71	139	147	143	135	144	154	132	180	184	252	261	265	160	108	125	83	61	57	33

AM Peak 1130 - 1230 (649), AM PHF=0.90 PM Peak 1700 - 1800 (1126), PM PHF=0.84

**Thursday, January 10, 2013=11538, 15 minute drops**

0000	0100	0200	0300	0400	0500	0600	0700	0800	0900	1000	1100	1200	1300	1400	1500	1600	1700	1800	1900	2000	2100	2200	2300	
180	112	88	118	175	253	331	481	559	466	502	613	629	667	683	904	1015	1094	835	506	426	406	264	231	
52	25	19	25	25	43	49	106	120	125	116	135	171	152	154	199	253	287	254	153	100	88	71	65	35
56	29	26	38	47	73	78	113	149	120	123	163	163	153	151	206	221	296	216	112	121	87	74	65	47
39	32	25	25	57	60	99	119	150	105	134	153	160	220	205	277	255	270	185	134	95	145	62	60	35
33	26	18	30	46	77	105	143	140	116	129	162	135	142	173	222	286	241	180	107	110	86	57	41	44

AM Peak 1145 - 1245 (656), AM PHF=0.96 PM Peak 1645 - 1745 (1139), PM PHF=0.96

# Southern Traffic Services, Inc.

## Event Counts

**Causeway Blvd east of US 41**

**Westbound**

**Datasets:**

**Site:** [123] !4467  
**Input A:** 8 - East bound A>B, West bound B>A. - Excluded from totals. (0)  
**Input B:** 0 - Unused or unknown. - Added to totals. (1)  
**Survey Duration:** 6:58 Monday, January 07, 2013 => 11:52 Friday, January 11, 2013  
**File:** G:\DATA\2013\Private\13015\diego\Data 1-7-13\UM123.eco (Plus)  
**Identifier:** P884EDXB MC56-L4 [MC55] (c)Microcom 19Sep03  
**Algorithm:** Event Count  
**Data type:** Axle sensors - Paired (Class, Speed, Count)

**Profile:**

**Filter time:** 0:00 Tuesday, January 08, 2013 => 0:00 Friday, January 11, 2013  
**Name:** Factory default profile  
**Scheme:** Count events divided by two.  
**Units:** Non metric (ft, mi, ft/s, mph, lb, ton)  
**In profile:** Events = 32789

**Tuesday, January 08, 2013=10914, 15 minute drops**

0000	0100	0200	0300	0400	0500	0600	0700	0800	0900	1000	1100	1200	1300	1400	1500	1600	1700	1800	1900	2000	2100	2200	2300	
<b>81</b>	<b>51</b>	<b>83</b>	<b>105</b>	<b>160</b>	<b>428</b>	<b>1011</b>	<b>1316</b>	<b>896</b>	<b>618</b>	<b>556</b>	<b>528</b>	<b>625</b>	<b>610</b>	<b>600</b>	<b>598</b>	<b>585</b>	<b>549</b>	<b>451</b>	<b>319</b>	<b>243</b>	<b>218</b>	<b>174</b>	<b>109</b>	
18	12	26	18	19	68	150	315	249	137	154	133	157	144	140	151	165	144	125	95	78	56	55	24	17
18	26	17	27	37	94	230	348	254	178	120	128	156	166	153	140	151	145	135	84	66	53	49	44	28
22	7	23	30	53	122	272	304	208	137	152	134	147	152	175	148	140	153	96	76	47	58	35	23	7
23	6	17	30	51	144	359	349	185	166	130	133	165	148	132	159	129	107	95	64	52	51	35	18	20

AM Peak 0645 - 0745 (1326), AM PHF=0.92 PM Peak 1245 - 1345 (627), PM PHF=0.94

**Wednesday, January 09, 2013=10955, 15 minute drops**

0000	0100	0200	0300	0400	0500	0600	0700	0800	0900	1000	1100	1200	1300	1400	1500	1600	1700	1800	1900	2000	2100	2200	2300	
<b>72</b>	<b>59</b>	<b>84</b>	<b>93</b>	<b>150</b>	<b>439</b>	<b>842</b>	<b>1386</b>	<b>970</b>	<b>606</b>	<b>564</b>	<b>603</b>	<b>636</b>	<b>577</b>	<b>588</b>	<b>565</b>	<b>581</b>	<b>574</b>	<b>465</b>	<b>349</b>	<b>233</b>	<b>206</b>	<b>181</b>	<b>132</b>	
17	23	17	21	17	71	128	358	277	141	132	133	137	137	165	146	140	159	130	94	49	46	47	37	25
28	14	16	23	43	107	233	359	274	170	147	144	198	160	134	145	154	144	125	101	62	59	51	32	10
7	17	22	29	49	133	283	285	252	157	137	152	166	144	143	149	155	142	110	74	55	47	39	34	14
20	5	29	20	41	128	198	384	167	138	148	174	135	136	146	125	132	129	100	80	67	54	44	29	24

AM Peak 0700 - 0800 (1386), AM PHF=0.90 PM Peak 1200 - 1300 (636), PM PHF=0.80

**Thursday, January 10, 2013=10920, 15 minute drops**

0000	0100	0200	0300	0400	0500	0600	0700	0800	0900	1000	1100	1200	1300	1400	1500	1600	1700	1800	1900	2000	2100	2200	2300	
<b>73</b>	<b>68</b>	<b>94</b>	<b>122</b>	<b>152</b>	<b>439</b>	<b>951</b>	<b>1305</b>	<b>886</b>	<b>635</b>	<b>526</b>	<b>592</b>	<b>608</b>	<b>570</b>	<b>583</b>	<b>576</b>	<b>570</b>	<b>539</b>	<b>466</b>	<b>360</b>	<b>273</b>	<b>231</b>	<b>165</b>	<b>136</b>	
25	16	19	19	24	80	159	317	238	167	126	157	153	131	141	135	144	153	148	104	89	49	48	34	17
10	17	15	26	25	99	202	330	244	163	140	130	140	113	129	148	146	122	134	109	74	63	48	32	20
14	11	34	45	45	129	312	325	241	143	132	157	154	179	166	132	160	148	96	70	43	65	36	41	20
24	24	26	32	58	131	278	333	163	162	128	148	161	147	147	161	120	116	88	77	67	54	33	29	14

AM Peak 0700 - 0800 (1305), AM PHF=0.98 PM Peak 1545 - 1645 (611), PM PHF=0.95

# Southern Traffic Services, Inc.

## Event Counts

**Causeway Blvd west of US 41**

**Eastbound**

**Datasets:**

**Site:** [124] I9025  
**Input A:** 2 - East bound, A hit first. - Added to totals. (1)  
**Input B:** 0 - Unused or unknown. - Excluded from totals. (0)  
**Survey Duration:** 7:01 Monday, January 07, 2013 => 11:49 Friday, January 11, 2013  
**File:** G:\DATA\2013\Private\13015\diego\Data 1-7-13\UM124 EB.eco (Plus)  
**Identifier:** AR27RD3H MC56-L5 [MC55] (c)Microcom 19Oct04  
**Algorithm:** Event Count  
**Data type:** Axle sensors - Paired (Class, Speed, Count)

**Profile:**

**Filter time:** 0:00 Tuesday, January 08, 2013 => 0:00 Friday, January 11, 2013  
**Name:** Factory default profile  
**Scheme:** Count events divided by two.  
**Units:** Non metric (ft, mi, ft/s, mph, lb, ton)  
**In profile:** Events = 53399

**Tuesday, January 08, 2013=17802, 15 minute drops**

0000	0100	0200	0300	0400	0500	0600	0700	0800	0900	1000	1100	1200	1300	1400	1500	1600	1700	1800	1900	2000	2100	2200	2300	
333	160	148	153	237	416	614	760	736	698	697	763	818	837	940	1507	1759	2166	1384	746	644	539	407	340	
149	46	35	40	63	62	114	175	192	177	171	178	224	202	234	315	367	573	428	201	173	125	138	97	49
78	49	46	34	41	91	159	190	190	173	173	185	200	229	246	349	429	511	375	188	183	142	101	71	45
57	22	34	37	72	145	171	167	177	180	187	200	197	203	206	412	426	568	317	184	175	148	96	92	40
49	43	33	42	61	118	170	228	177	168	166	200	197	203	254	431	537	514	264	173	113	124	72	80	28

AM Peak 1130 - 1230 (824), AM PHF=0.92 PM Peak 1645 - 1745 (2189), PM PHF=0.96

**Wednesday, January 09, 2013=17860, 15 minute drops**

0000	0100	0200	0300	0400	0500	0600	0700	0800	0900	1000	1100	1200	1300	1400	1500	1600	1700	1800	1900	2000	2100	2200	2300	
162	175	127	129	255	429	638	765	720	688	711	840	790	918	1006	1425	1750	2055	1352	730	664	587	502	442	
49	67	36	29	70	62	110	165	175	168	191	177	224	196	258	252	428	519	387	202	160	152	133	119	75
45	36	27	28	50	102	156	204	180	163	168	230	187	248	230	383	431	461	413	203	150	141	155	95	77
40	39	35	29	74	146	178	188	189	184	178	216	197	238	255	364	415	553	288	175	185	145	109	116	65
28	33	29	43	61	119	194	208	176	173	174	217	182	236	263	426	476	522	264	150	169	149	105	112	50

AM Peak 1115 - 1215 (887), AM PHF=0.96 PM Peak 1700 - 1800 (2055), PM PHF=0.93

**Thursday, January 10, 2013=17737, 15 minute drops**

0000	0100	0200	0300	0400	0500	0600	0700	0800	0900	1000	1100	1200	1300	1400	1500	1600	1700	1800	1900	2000	2100	2200	2300	
267	175	145	151	270	434	639	744	741	632	698	749	850	886	1004	1385	1789	1930	1375	783	679	559	466	386	
75	45	37	38	58	68	136	169	172	140	160	172	203	208	230	298	426	515	356	252	158	119	117	96	71
77	44	36	40	71	106	137	196	199	168	157	198	247	236	220	299	392	481	367	198	202	149	129	110	71
65	52	45	35	77	138	174	201	191	168	189	189	218	225	284	411	452	492	346	184	147	158	126	97	60
50	34	27	38	64	122	192	178	179	156	192	190	182	217	270	377	519	442	306	149	172	133	94	83	47

AM Peak 1145 - 1245 (858), AM PHF=0.87 PM Peak 1645 - 1745 (2007), PM PHF=0.97

# Southern Traffic Services, Inc.

## Event Counts

**Causeway Blvd west of US 41**

**Westbound**

**Datasets:**

**Site:** [124] !8005  
**Input A:** 4 - West bound, A hit first. - Added to totals. (1)  
**Input B:** 0 - Unused or unknown. - Excluded from totals. (0)  
**Survey Duration:** 7:02 Monday, January 07, 2013 => 11:47 Friday, January 11, 2013  
**File:** G:\DATA\2013\Private\13015\diego\Data 1-7-13\UM124 WB.eco (Plus)  
**Identifier:** W00743F1 MC56-L5 [MC55] (c)Microcom 19Oct04  
**Algorithm:** Event Count  
**Data type:** Axle sensors - Paired (Class, Speed, Count)

**Profile:**

**Filter time:** 0:00 Tuesday, January 08, 2013 => 0:00 Friday, January 11, 2013  
**Name:** Factory default profile  
**Scheme:** Count events divided by two.  
**Units:** Non metric (ft, mi, ft/s, mph, lb, ton)  
**In profile:** Events = 50315

**Tuesday, January 08, 2013=16756, 15 minute drops**

0000	0100	0200	0300	0400	0500	0600	0700	0800	0900	1000	1100	1200	1300	1400	1500	1600	1700	1800	1900	2000	2100	2200	2300	
101	87	107	164	294	783	1695	2381	1620	990	853	722	792	846	792	835	911	829	680	387	256	265	223	143	
27	14	29	36	42	144	299	599	473	278	203	174	206	233	193	215	253	225	168	108	63	59	73	45	20
23	38	23	34	65	174	438	621	455	285	217	162	192	188	257	204	237	218	193	96	64	68	66	42	34
25	18	34	38	88	227	345	581	408	208	213	190	213	220	198	246	211	196	176	97	63	72	46	35	18
26	17	21	56	99	238	613	580	284	219	220	196	181	205	144	170	210	190	143	86	66	66	38	21	22

AM Peak 0645 - 0745 (2414), AM PHF=0.97 PM Peak 1600 - 1700 (911), PM PHF=0.90

**Wednesday, January 09, 2013=16860, 15 minute drops**

0000	0100	0200	0300	0400	0500	0600	0700	0800	0900	1000	1100	1200	1300	1400	1500	1600	1700	1800	1900	2000	2100	2200	2300	
94	98	117	187	293	788	1550	2333	1664	894	860	815	892	761	839	857	832	892	683	415	304	305	238	149	
20	32	30	34	47	121	294	560	493	250	210	183	166	176	202	227	196	260	199	103	74	73	67	39	26
34	29	23	50	65	174	341	640	469	214	239	207	288	207	241	191	217	211	186	132	76	90	73	48	11
18	27	36	63	90	234	588	554	415	210	197	220	226	180	225	212	224	222	171	94	65	62	52	30	14
22	10	28	40	91	259	327	579	287	220	214	205	212	198	171	227	195	199	127	86	89	80	46	32	19

AM Peak 0700 - 0800 (2333), AM PHF=0.91 PM Peak 1215 - 1315 (902), PM PHF=0.78

**Thursday, January 10, 2013=16699, 15 minute drops**

0000	0100	0200	0300	0400	0500	0600	0700	0800	0900	1000	1100	1200	1300	1400	1500	1600	1700	1800	1900	2000	2100	2200	2300	
70	107	128	160	287	796	1664	2304	1454	1026	792	847	793	790	850	845	848	822	667	429	312	308	245	155	
26	26	29	25	40	143	317	561	376	312	197	224	221	190	235	219	219	224	195	138	88	67	65	32	13
11	27	25	37	60	176	399	572	518	256	216	184	189	134	194	185	210	201	219	113	82	93	71	45	26
14	34	38	55	90	239	441	625	375	215	199	239	207	220	208	236	228	203	143	78	70	74	63	42	24
19	20	36	43	97	238	507	546	185	243	180	200	176	246	213	205	191	194	110	100	72	74	46	36	14

AM Peak 0700 - 0800 (2304), AM PHF=0.92 PM Peak 1330 - 1430 (895), PM PHF=0.91

**SPECIAL TURNING MOVEMENT COUNTS FOR  
ACCESS TO THE PORT**



# Southern Traffic Services, Inc.

2911 Westfield Rd  
Gulf Breeze, FL 32563  
1-800-786-3374

*Traffic is our only business!*

US 41 @ Riverview Dr  
Tampa, FL

File Name : 13015-8 US 41 @ RIVERVIEW DR  
Site Code : 13015-8  
Start Date : 1/10/2013  
Page No : 1

Groups Printed- Automobiles - Trucks - Buses

Start Time	US 41 Southbound				RIVERVIEW DR Westbound				US 41 Northbound				RIVERVIEW DR Eastbound				Int. Total
	Left	Thru	Right	U-Turns	Left	Thru	Right	U-Turns	Left	Thru	Right	U-Turns	Left	Thru	Right	U-Turns	
09:00 AM	12	143	7	0	18	5	10	0	4	155	28	0	2	0	10	0	394
09:15 AM	4	85	4	0	20	2	12	0	10	149	14	0	5	2	2	0	309
09:30 AM	4	95	4	0	15	3	6	0	8	139	21	0	1	2	3	0	301
09:45 AM	6	109	6	1	16	2	7	0	9	126	23	1	4	2	2	0	314
Total	26	432	21	1	69	12	35	0	31	569	86	1	12	6	17	0	1318
10:00 AM	4	86	1	0	34	1	11	0	5	103	36	0	3	2	6	0	292
10:15 AM	9	94	2	0	21	0	12	0	7	153	28	0	5	2	2	0	335
10:30 AM	3	87	1	0	24	3	6	0	7	56	21	1	2	0	8	0	219
10:45 AM	6	133	2	0	19	3	4	0	8	174	32	1	2	4	7	0	395
Total	22	400	6	0	98	7	33	0	27	486	117	2	12	8	23	0	1241
11:00 AM	10	96	4	0	29	0	10	0	3	112	40	0	5	5	0	0	314
11:15 AM	11	81	2	0	28	4	10	0	9	122	24	0	6	10	13	0	320
11:30 AM	7	106	4	0	27	4	11	0	4	111	36	0	5	7	5	0	327
11:45 AM	9	110	4	0	18	1	11	0	7	113	35	0	2	7	4	0	321
Total	37	393	14	0	102	9	42	0	23	458	135	0	18	29	22	0	1282
12:00 PM	6	112	4	0	34	9	4	0	4	108	34	0	3	5	12	0	335
12:15 PM	7	136	4	0	27	2	3	0	16	117	26	0	1	3	7	0	349
12:30 PM	14	135	0	0	32	5	3	0	18	122	27	4	6	11	4	0	381
12:45 PM	6	98	2	0	29	3	6	0	19	113	35	1	1	0	4	0	317
Total	33	481	10	0	122	19	16	0	57	460	122	5	11	19	27	0	1382
Grand Total	118	1706	51	1	391	47	126	0	138	1973	460	8	53	62	89	0	5223
Apprch %	6.3	90.9	2.7	0.1	69.3	8.3	22.3	0	5.4	76.5	17.8	0.3	26	30.4	43.6	0	
Total %	2.3	32.7	1	0	7.5	0.9	2.4	0	2.6	37.8	8.8	0.2	1	1.2	1.7	0	
Automobiles	109	1468	51	1	365	44	118	0	126	1753	438	8	49	61	76	0	4667
% Automobiles	92.4	86	100	100	93.4	93.6	93.7	0	91.3	88.8	95.2	100	92.5	98.4	85.4	0	89.4
Trucks	8	232	0	0	26	3	8	0	12	219	20	0	4	1	13	0	546
% Trucks	6.8	13.6	0	0	6.6	6.4	6.3	0	8.7	11.1	4.3	0	7.5	1.6	14.6	0	10.5
Buses	1	6	0	0	0	0	0	0	0	1	2	0	0	0	0	0	10
% Buses	0.8	0.4	0	0	0	0	0	0	0	0.1	0.4	0	0	0	0	0	0.2



# Southern Traffic Services, Inc.

2911 Westfield Rd  
 Gulf Breeze, FL 32563  
 1-800-786-3374

*Traffic is our only business!*

US 41 @ Riverview Dr  
 Tampa, FL

File Name : 13015-8 US 41 @ RIVERVIEW DR  
 Site Code : 13015-8  
 Start Date : 1/10/2013  
 Page No : 2

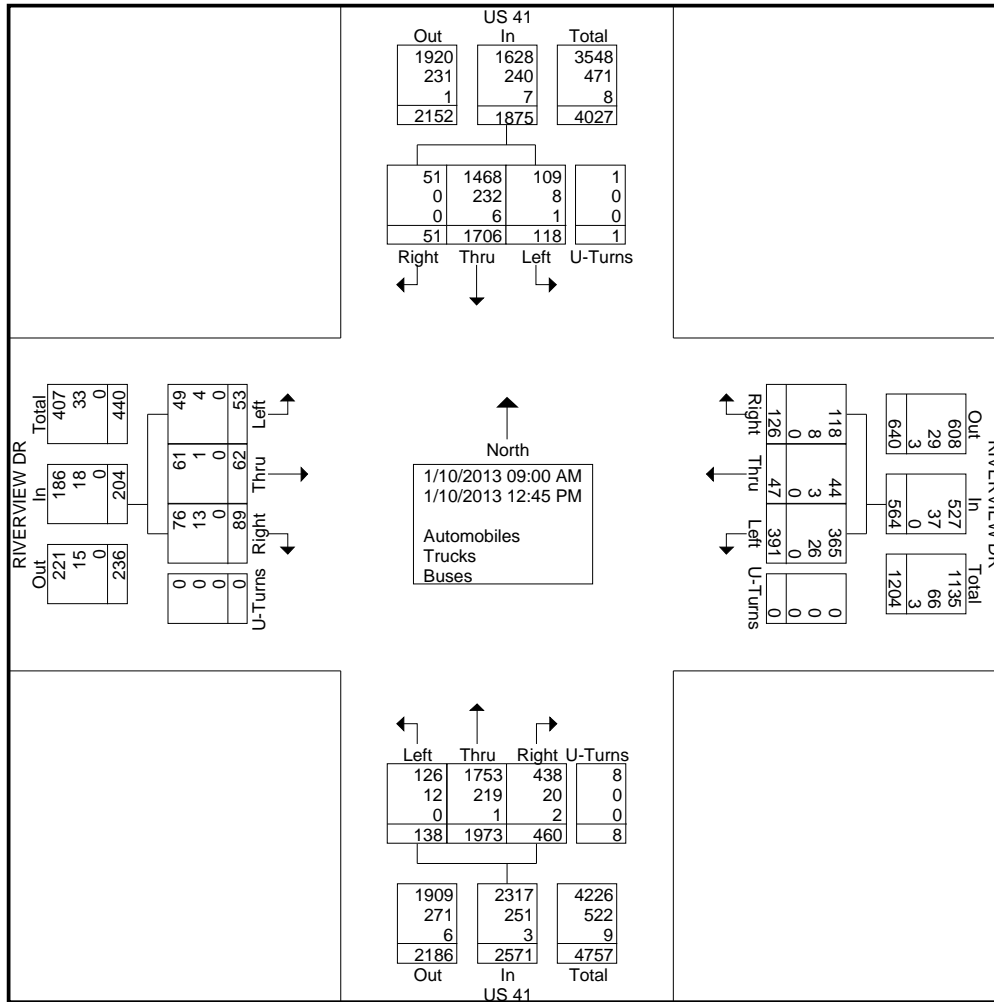





# Southern Traffic Services, Inc.

2911 Westfield Rd  
Gulf Breeze, FL 32563  
1-800-786-3374

*Traffic is our only business!*

US 41 @ Riverview Dr  
Tampa, FL

File Name : 13015-8 US 41 @ RIVERVIEW DR  
Site Code : 13015-8  
Start Date : 1/10/2013  
Page No : 3

Start Time	US 41 Southbound				RIVERVIEW DR Westbound				US 41 Northbound				RIVERVIEW DR Eastbound				Int. Total				
	Thru	Right	U-Turns	App. Total	Left	Thru	Right	U-Turns	App. Total	Left	Thru	Right	U-Turns	App. Total	Left	Thru		Right	U-Turns	App. Total	
Peak Hour Analysis From 09:00 AM to 12:45 PM - Peak 1 of 1																					
Peak Hour for Entire Intersection Begins at 11:45 AM																					
11:45 AM	9	110	4	0	123	18	1	11	0	30	7	113	35	0	155	2	7	4	0	13	321
12:00 PM	6	112	4	0	122	34	9	4	0	47	4	108	34	0	146	3	5	12	0	20	335
12:15 PM	7	136	4	0	147	27	2	3	0	32	16	117	26	0	159	1	3	7	0	11	349
12:30 PM	14	135	0	0	149	32	5	3	0	40	18	122	27	4	171	6	11	4	0	21	381
Total Volume	36	493	12	0	541	111	17	21	0	149	45	460	122	4	631	12	26	27	0	65	1386
% App. Total	6.7	91.1	2.2	0		74.5	11.4	14.1	0		7.1	72.9	19.3	0.6		18.5	40	41.5	0		
PHF	.643	.906	.750	.000	.908	.816	.472	.477	.000	.793	.625	.943	.871	.250	.923	.500	.591	.563	.000	.774	.909
Automobiles	35	430	12	0	477	108	16	19	0	143	41	411	115	4	571	11	25	26	0	62	1253
% Automobiles	97.2	87.2	100	0	88.2	97.3	94.1	90.5	0	96.0	91.1	89.3	94.3	100	90.5	91.7	96.2	96.3	0	95.4	90.4
Trucks	1	61	0	0	62	3	1	2	0	6	4	49	6	0	59	1	1	1	0	3	130
% Trucks	2.8	12.4	0	0	11.5	2.7	5.9	9.5	0	4.0	8.9	10.7	4.9	0	9.4	8.3	3.8	3.7	0	4.6	9.4
Buses	0	2	0	0	2	0	0	0	0	0	0	0	1	0	1	0	0	0	0	0	3
% Buses	0	0.4	0	0	0.4	0	0	0	0	0	0	0	0.8	0	0.2	0	0	0	0	0	0.2

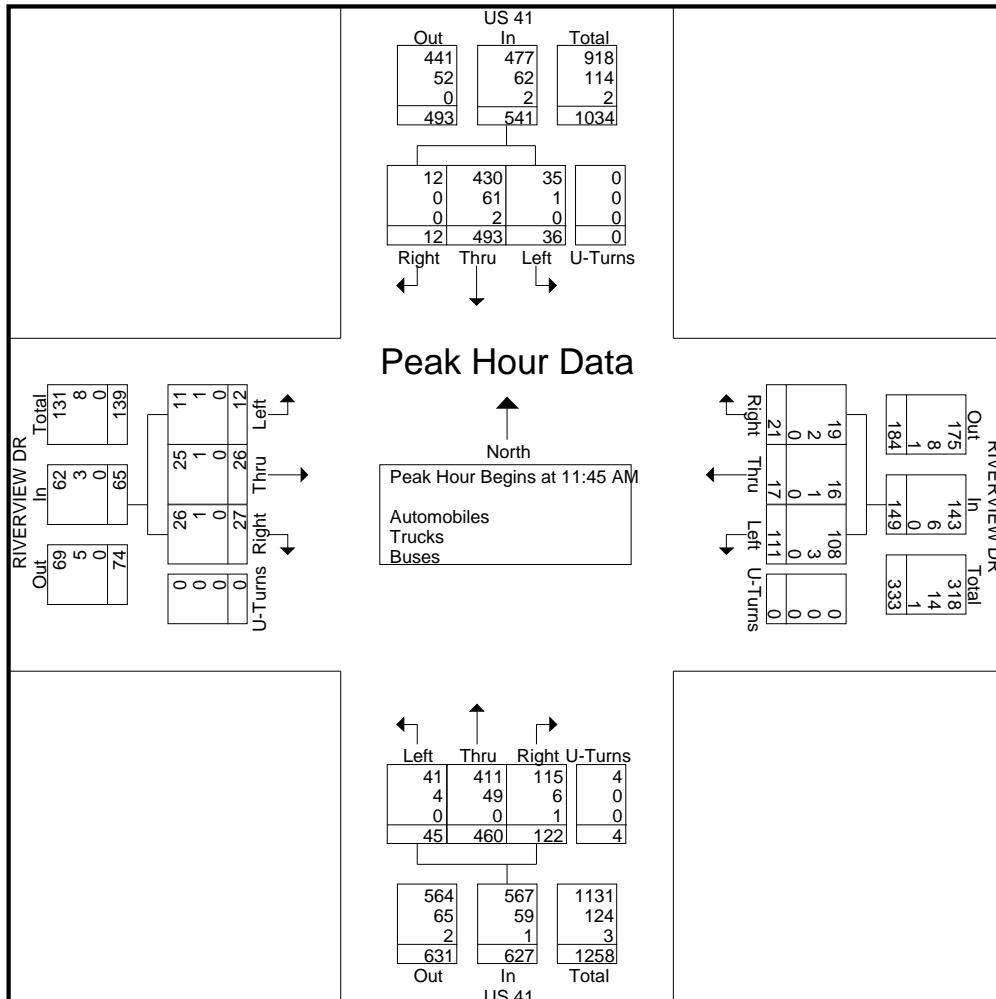



# Southern Traffic Services, Inc.

2911 Westfield Rd  
 Gulf Breeze, FL 32563  
 1-800-786-3374

*Traffic is our only business!*

US 41 @ Riverview Dr  
 Tampa, FL

File Name : 13015-8 US 41 @ RIVERVIEW DR  
 Site Code : 13015-8  
 Start Date : 1/10/2013  
 Page No : 1

Groups Printed- Automobiles

Start Time	US 41 Southbound				RIVERVIEW DR Westbound				US 41 Northbound				RIVERVIEW DR Eastbound				Int. Total
	Left	Thru	Right	U-Turns	Left	Thru	Right	U-Turns	Left	Thru	Right	U-Turns	Left	Thru	Right	U-Turns	
09:00 AM	11	119	7	0	16	5	9	0	4	144	26	0	1	0	9	0	351
09:15 AM	4	73	4	0	20	2	10	0	10	130	13	0	5	2	2	0	275
09:30 AM	3	88	4	0	13	2	6	0	7	122	21	0	1	2	2	0	271
09:45 AM	5	92	6	1	13	2	7	0	6	113	19	1	4	2	2	0	273
<b>Total</b>	<b>23</b>	<b>372</b>	<b>21</b>	<b>1</b>	<b>62</b>	<b>11</b>	<b>32</b>	<b>0</b>	<b>27</b>	<b>509</b>	<b>79</b>	<b>1</b>	<b>11</b>	<b>6</b>	<b>15</b>	<b>0</b>	<b>1170</b>
10:00 AM	3	77	1	0	30	1	11	0	5	91	35	0	3	2	2	0	261
10:15 AM	9	84	2	0	20	0	11	0	5	133	28	0	4	2	2	0	300
10:30 AM	2	72	1	0	23	3	6	0	7	50	21	1	2	0	6	0	194
10:45 AM	6	112	2	0	15	3	4	0	8	151	31	1	2	4	4	0	343
<b>Total</b>	<b>20</b>	<b>345</b>	<b>6</b>	<b>0</b>	<b>88</b>	<b>7</b>	<b>32</b>	<b>0</b>	<b>25</b>	<b>425</b>	<b>115</b>	<b>2</b>	<b>11</b>	<b>8</b>	<b>14</b>	<b>0</b>	<b>1098</b>
11:00 AM	8	82	4	0	29	0	10	0	3	101	38	0	4	5	0	0	284
11:15 AM	11	67	2	0	28	3	8	0	9	112	23	0	6	10	12	0	291
11:30 AM	6	88	4	0	24	4	11	0	4	95	35	0	5	7	5	0	288
11:45 AM	9	95	4	0	17	1	11	0	7	103	33	0	2	7	4	0	293
<b>Total</b>	<b>34</b>	<b>332</b>	<b>14</b>	<b>0</b>	<b>98</b>	<b>8</b>	<b>40</b>	<b>0</b>	<b>23</b>	<b>411</b>	<b>129</b>	<b>0</b>	<b>17</b>	<b>29</b>	<b>21</b>	<b>0</b>	<b>1156</b>
12:00 PM	6	100	4	0	33	8	3	0	4	94	32	0	3	5	12	0	304
12:15 PM	7	121	4	0	26	2	2	0	14	105	24	0	1	3	6	0	315
12:30 PM	13	114	0	0	32	5	3	0	16	109	26	4	5	10	4	0	341
12:45 PM	6	84	2	0	26	3	6	0	17	100	33	1	1	0	4	0	283
<b>Total</b>	<b>32</b>	<b>419</b>	<b>10</b>	<b>0</b>	<b>117</b>	<b>18</b>	<b>14</b>	<b>0</b>	<b>51</b>	<b>408</b>	<b>115</b>	<b>5</b>	<b>10</b>	<b>18</b>	<b>26</b>	<b>0</b>	<b>1243</b>
<b>Grand Total</b>	<b>109</b>	<b>1468</b>	<b>51</b>	<b>1</b>	<b>365</b>	<b>44</b>	<b>118</b>	<b>0</b>	<b>126</b>	<b>1753</b>	<b>438</b>	<b>8</b>	<b>49</b>	<b>61</b>	<b>76</b>	<b>0</b>	<b>4667</b>
Apprch %	6.7	90.1	3.1	0.1	69.3	8.3	22.4	0	5.4	75.4	18.8	0.3	26.3	32.8	40.9	0	
Total %	2.3	31.5	1.1	0	7.8	0.9	2.5	0	2.7	37.6	9.4	0.2	1	1.3	1.6	0	



# Southern Traffic Services, Inc.

2911 Westfield Rd  
Gulf Breeze, FL 32563  
1-800-786-3374

*Traffic is our only business!*

US 41 @ Riverview Dr  
Tampa, FL

File Name : 13015-8 US 41 @ RIVERVIEW DR  
Site Code : 13015-8  
Start Date : 1/10/2013  
Page No : 2

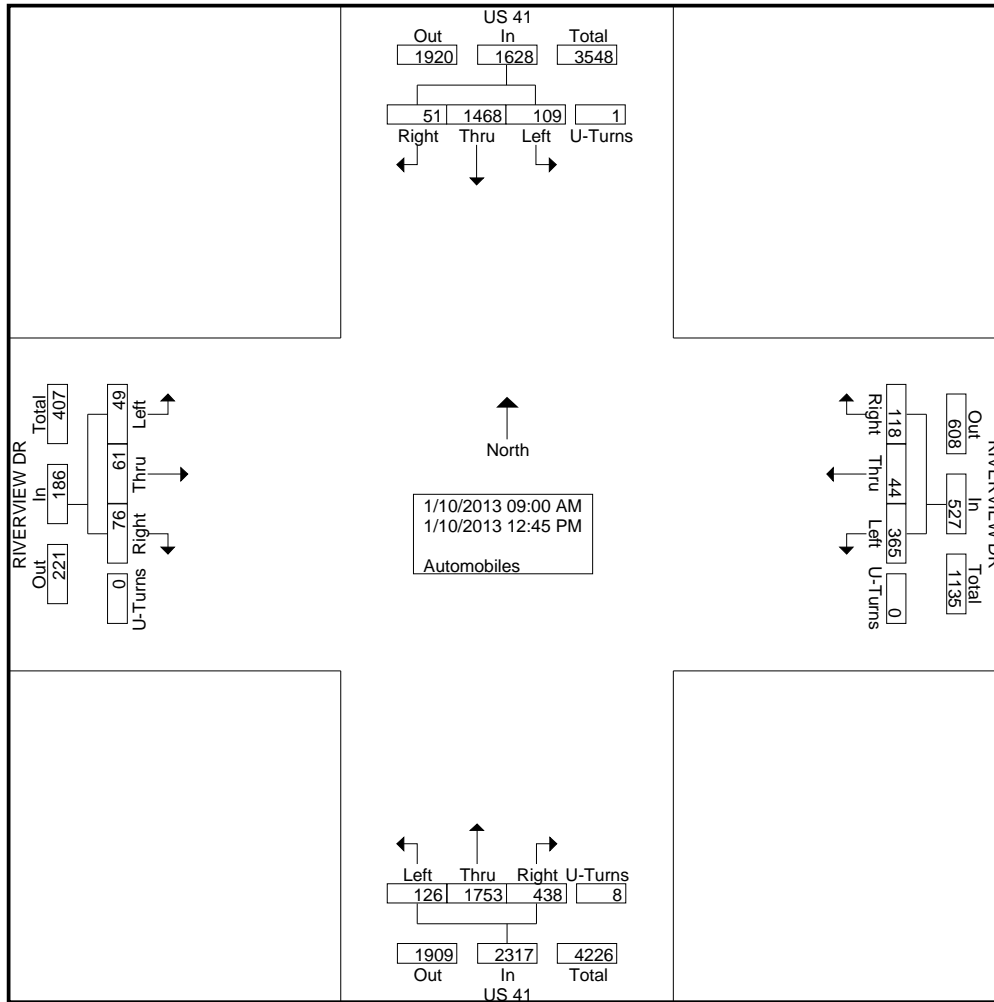



# Southern Traffic Services, Inc.

2911 Westfield Rd  
Gulf Breeze, FL 32563  
1-800-786-3374

*Traffic is our only business!*

US 41 @ Riverview Dr  
Tampa, FL

File Name : 13015-8 US 41 @ RIVERVIEW DR  
Site Code : 13015-8  
Start Date : 1/10/2013  
Page No : 3

Start Time	US 41 Southbound				RIVERVIEW DR Westbound				US 41 Northbound				RIVERVIEW DR Eastbound				Int. Total				
	Thru	Right	U-Turns	App. Total	Left	Thru	Right	U-Turns	App. Total	Left	Thru	Right	U-Turns	App. Total	Left	Thru		Right	U-Turns	App. Total	
Peak Hour Analysis From 09:00 AM to 12:45 PM - Peak 1 of 1																					
Peak Hour for Entire Intersection Begins at 11:45 AM																					
11:45 AM	9	95	4	0	108	17	1	11	0	29	7	103	33	0	143	2	7	4	0	13	293
12:00 PM	6	100	4	0	110	33	8	3	0	44	4	94	32	0	130	3	5	12	0	20	304
12:15 PM	7	121	4	0	132	26	2	2	0	30	14	105	24	0	143	1	3	6	0	10	315
12:30 PM	13	114	0	0	127	32	5	3	0	40	16	109	26	4	155	5	10	4	0	19	341
Total Volume	35	430	12	0	477	108	16	19	0	143	41	411	115	4	571	11	25	26	0	62	1253
% App. Total	7.3	90.1	2.5	0		75.5	11.2	13.3	0		7.2	72	20.1	0.7		17.7	40.3	41.9	0		
PHF	.673	.888	.750	.000	.903	.818	.500	.432	.000	.813	.641	.943	.871	.250	.921	.550	.625	.542	.000	.775	.919

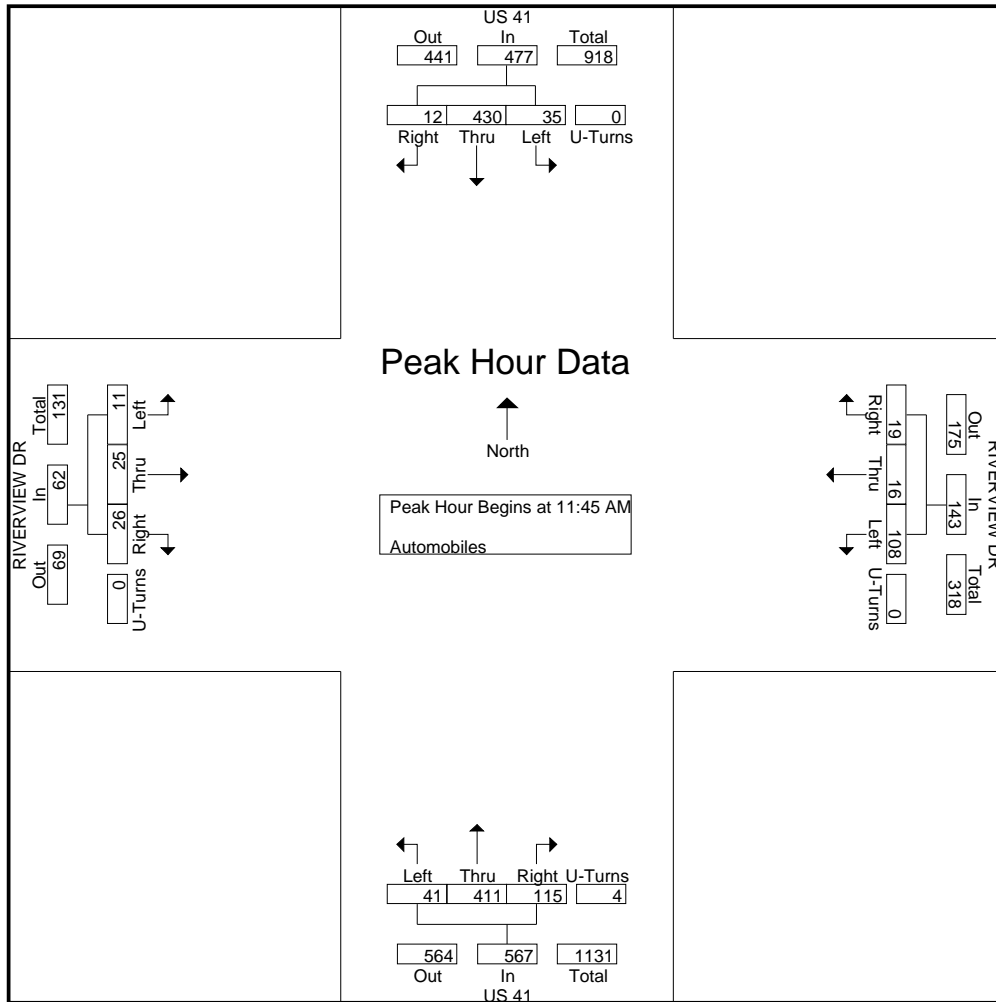



# Southern Traffic Services, Inc.

2911 Westfield Rd  
Gulf Breeze, FL 32563  
1-800-786-3374

*Traffic is our only business!*

US 41 @ Riverview Dr  
Tampa, FL

File Name : 13015-8 US 41 @ RIVERVIEW DR  
Site Code : 13015-8  
Start Date : 1/10/2013  
Page No : 1

Groups Printed- Trucks - Buses

Start Time	US 41 Southbound				RIVERVIEW DR Westbound				US 41 Northbound				RIVERVIEW DR Eastbound				Int. Total
	Left	Thru	Right	U-Turns	Left	Thru	Right	U-Turns	Left	Thru	Right	U-Turns	Left	Thru	Right	U-Turns	
09:00 AM	1	24	0	0	2	0	1	0	0	11	2	0	1	0	1	0	43
09:15 AM	0	12	0	0	0	0	2	0	0	19	1	0	0	0	0	0	34
09:30 AM	1	7	0	0	2	1	0	0	1	17	0	0	0	0	1	0	30
09:45 AM	1	17	0	0	3	0	0	0	3	13	4	0	0	0	0	0	41
Total	3	60	0	0	7	1	3	0	4	60	7	0	1	0	2	0	148
10:00 AM	1	9	0	0	4	0	0	0	0	12	1	0	0	0	4	0	31
10:15 AM	0	10	0	0	1	0	1	0	2	20	0	0	1	0	0	0	35
10:30 AM	1	15	0	0	1	0	0	0	0	6	0	0	0	0	2	0	25
10:45 AM	0	21	0	0	4	0	0	0	0	23	1	0	0	0	3	0	52
Total	2	55	0	0	10	0	1	0	2	61	2	0	1	0	9	0	143
11:00 AM	2	14	0	0	0	0	0	0	0	11	2	0	1	0	0	0	30
11:15 AM	0	14	0	0	0	1	2	0	0	10	1	0	0	0	1	0	29
11:30 AM	1	18	0	0	3	0	0	0	0	16	1	0	0	0	0	0	39
11:45 AM	0	15	0	0	1	0	0	0	0	10	2	0	0	0	0	0	28
Total	3	61	0	0	4	1	2	0	0	47	6	0	1	0	1	0	126
12:00 PM	0	12	0	0	1	1	1	0	0	14	2	0	0	0	0	0	31
12:15 PM	0	15	0	0	1	0	1	0	2	12	2	0	0	0	1	0	34
12:30 PM	1	21	0	0	0	0	0	0	2	13	1	0	1	1	0	0	40
12:45 PM	0	14	0	0	3	0	0	0	2	13	2	0	0	0	0	0	34
Total	1	62	0	0	5	1	2	0	6	52	7	0	1	1	1	0	139
Grand Total	9	238	0	0	26	3	8	0	12	220	22	0	4	1	13	0	556
Apprch %	3.6	96.4	0	0	70.3	8.1	21.6	0	4.7	86.6	8.7	0	22.2	5.6	72.2	0	
Total %	1.6	42.8	0	0	4.7	0.5	1.4	0	2.2	39.6	4	0	0.7	0.2	2.3	0	
Trucks	8	232	0	0	26	3	8	0	12	219	20	0	4	1	13	0	546
% Trucks	88.9	97.5	0	0	100	100	100	0	100	99.5	90.9	0	100	100	100	0	98.2
Buses	1	6	0	0	0	0	0	0	0	1	2	0	0	0	0	0	10
% Buses	11.1	2.5	0	0	0	0	0	0	0	0.5	9.1	0	0	0	0	0	1.8



# Southern Traffic Services, Inc.

2911 Westfield Rd  
 Gulf Breeze, FL 32563  
 1-800-786-3374

*Traffic is our only business!*

US 41 @ Riverview Dr  
 Tampa, FL

File Name : 13015-8 US 41 @ RIVERVIEW DR  
 Site Code : 13015-8  
 Start Date : 1/10/2013  
 Page No : 2

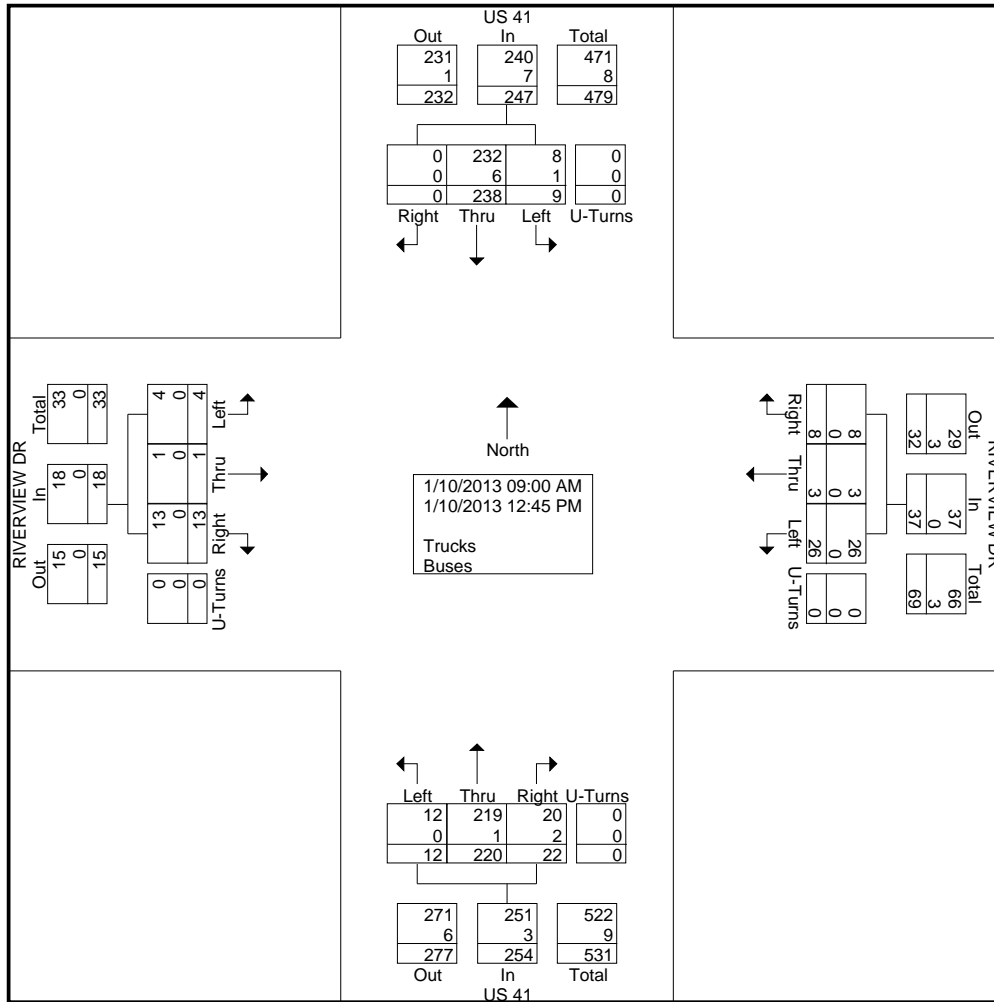



# Southern Traffic Services, Inc.

2911 Westfield Rd  
Gulf Breeze, FL 32563  
1-800-786-3374

*Traffic is our only business!*

US 41 @ Riverview Dr  
Tampa, FL

File Name : 13015-8 US 41 @ RIVERVIEW DR  
Site Code : 13015-8  
Start Date : 1/10/2013  
Page No : 3

Start Time	US 41 Southbound				RIVERVIEW DR Westbound				US 41 Northbound				RIVERVIEW DR Eastbound				Int. Total				
	Thru	Right	U-Turns	App. Total	Left	Thru	Right	U-Turns	App. Total	Left	Thru	Right	U-Turns	App. Total	Left	Thru		Right	U-Turns	App. Total	
Peak Hour Analysis From 09:00 AM to 12:45 PM - Peak 1 of 1																					
Peak Hour for Entire Intersection Begins at 10:45 AM																					
10:45 AM	0	21	0	0	21	4	0	0	0	4	0	23	1	0	24	0	0	3	0	3	52
11:00 AM	2	14	0	0	16	0	0	0	0	0	0	11	2	0	13	1	0	0	0	1	30
11:15 AM	0	14	0	0	14	0	1	2	0	3	0	10	1	0	11	0	0	1	0	1	29
11:30 AM	1	18	0	0	19	3	0	0	0	3	0	16	1	0	17	0	0	0	0	0	39
Total Volume	3	67	0	0	70	7	1	2	0	10	0	60	5	0	65	1	0	4	0	5	150
% App. Total	4.3	95.7	0	0		7.0	10	2.0	0		0	92.3	7.7	0		2.0	0	8.0	0		
PHF	.375	.798	.000	.000	.833	.438	.250	.250	.000	.625	.000	.652	.625	.000	.677	.250	.000	.333	.000	.417	.721

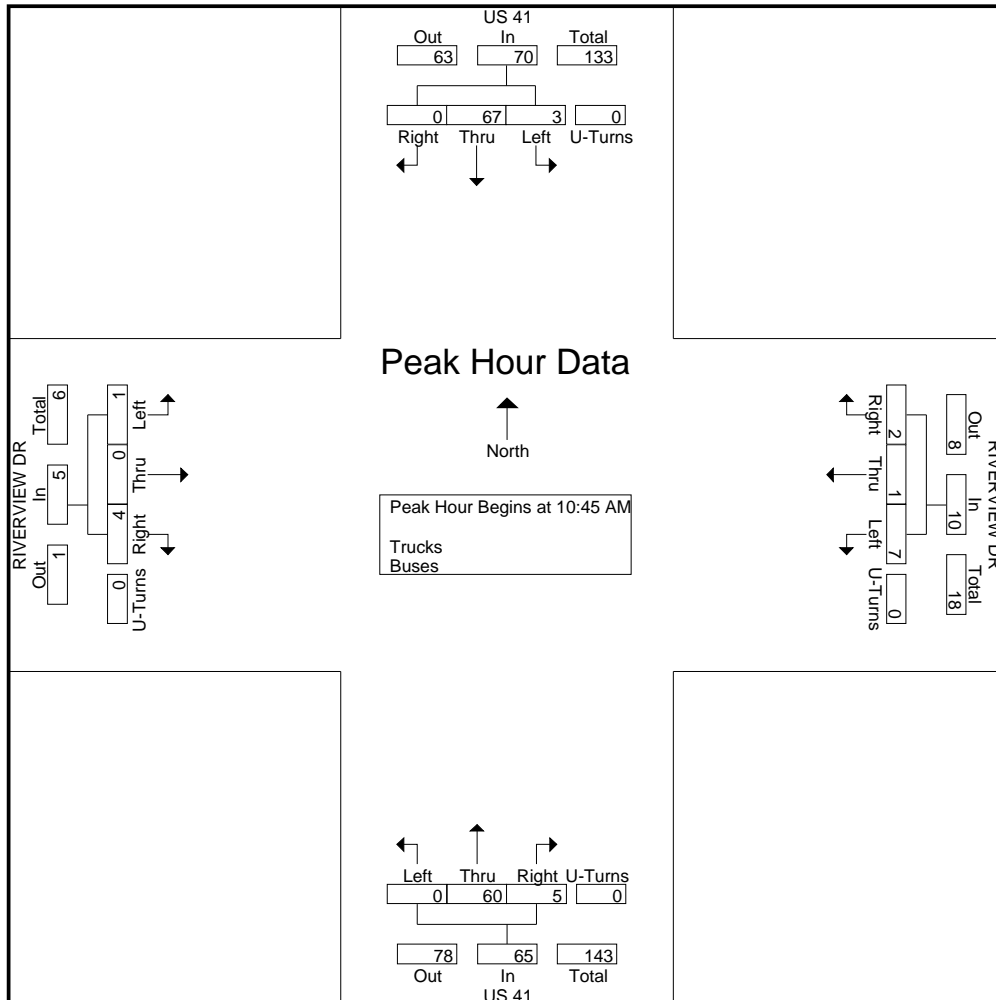



# Southern Traffic Services, Inc.

2911 Westfield Rd  
 Gulf Breeze, FL 32563  
 1-800-786-3374

*Traffic is our only business!*

File Name : 13015-8 US 41 @ RIVERVIEW DR Peds

Site Code : 13015-8

Start Date : 1/10/2013

Page No : 1

Groups Printed- Peds

	US 41 Southbound	RIVERVIEW DR Westbound	US 41 Northbound	RIVERVIEW DR Eastbound	
Start Time	Peds	Peds	Peds	Peds	Int. Total
09:00 AM	0	0	0	0	0
09:15 AM	0	0	0	0	0
09:30 AM	0	0	0	0	0
09:45 AM	0	0	0	0	0
Total	0	0	0	0	0
10:00 AM	0	0	1	0	1
10:15 AM	0	0	0	0	0
10:30 AM	0	0	0	0	0
10:45 AM	0	0	0	0	0
Total	0	0	1	0	1
11:00 AM	0	0	0	0	0
11:15 AM	0	0	0	1	1
11:30 AM	0	0	0	0	0
11:45 AM	0	0	0	0	0
Total	0	0	0	1	1
12:00 PM	0	0	0	1	1
12:15 PM	0	0	0	0	0
12:30 PM	0	0	0	0	0
12:45 PM	0	0	0	0	0
Total	0	0	0	1	1
Grand Total	0	0	1	2	3
Apprch %	0	0	100	100	
Total %	0	0	33.3	66.7	





# Southern Traffic Services, Inc.

2911 Westfield Rd  
Gulf Breeze, FL 32563  
1-800-786-3374

*Traffic is our only business!*

File Name : 13015-8 US 41 @ RIVERVIEW DR Peds

Site Code : 13015-8

Start Date : 1/10/2013

Page No : 2

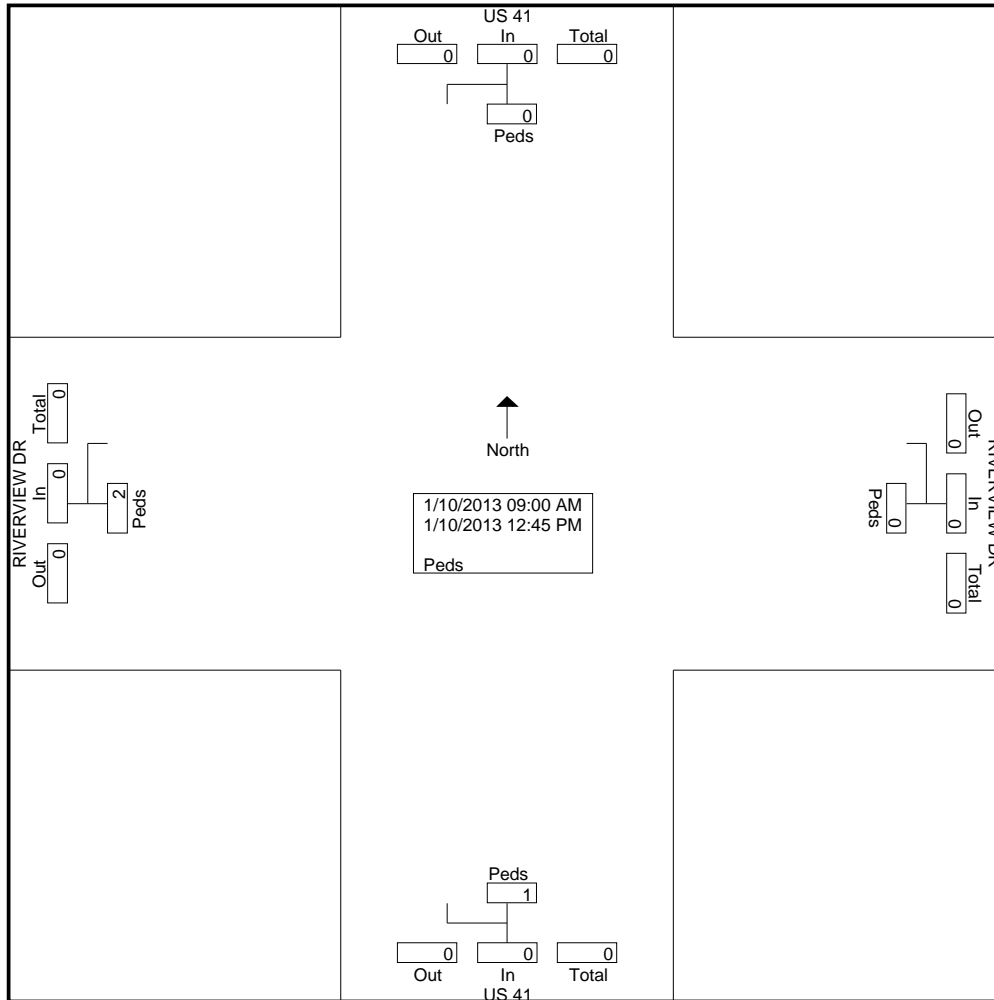





# Southern Traffic Services, Inc.

2911 Westfield Rd  
 Gulf Breeze, FL 32563  
 1-800-786-3374

*Traffic is our only business!*

US 41 @ Madison Ave  
 Tampa, FL

File Name : 13015-9 US 41 @ Madison Ave  
 Site Code : 13015-9  
 Start Date : 3/7/2013  
 Page No : 2

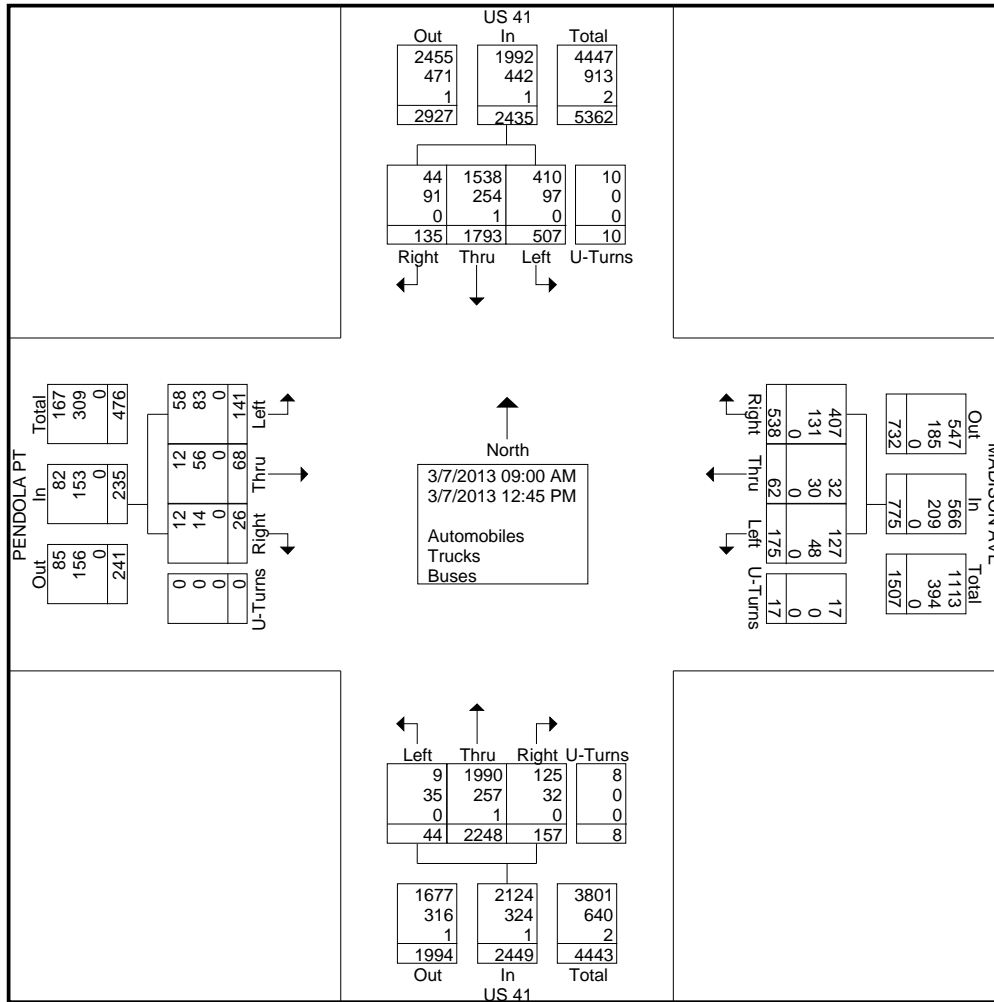



# Southern Traffic Services, Inc.

2911 Westfield Rd  
Gulf Breeze, FL 32563  
1-800-786-3374

*Traffic is our only business!*

US 41 @ Madison Ave  
Tampa, FL

File Name : 13015-9 US 41 @ Madison Ave  
Site Code : 13015-9  
Start Date : 3/7/2013  
Page No : 3

Start Time	US 41 Southbound					MADISON AVE Westbound					US 41 Northbound					PENDOLA PT Eastbound					Int. Total
	Thru	Right	U-Turns	App. Total	Left	Thru	Right	U-Turns	App. Total	Left	Thru	Right	U-Turns	App. Total	Left	Thru	Right	U-Turns	App. Total		
Peak Hour Analysis From 09:00 AM to 12:45 PM - Peak 1 of 1																					
Peak Hour for Entire Intersection Begins at 11:45 AM																					
11:45 AM	53	106	11	0	170	10	6	34	2	52	1	135	16	0	152	17	12	3	0	32	406
12:00 PM	46	131	6	2	185	14	12	32	2	60	4	144	12	1	161	19	2	2	0	23	429
12:15 PM	39	143	13	0	195	9	4	35	2	50	1	112	13	1	127	6	7	3	0	16	388
12:30 PM	39	135	9	1	184	18	5	38	1	62	2	130	6	1	139	9	0	3	0	12	397
Total Volume	177	515	39	3	734	51	27	139	7	224	8	521	47	3	579	51	21	11	0	83	1620
% App. Total	24.1	70.2	5.3	0.4		22.8	12.1	62.1	3.1		1.4	90	8.1	0.5		61.4	25.3	13.3	0		
PHF	.835	.900	.750	.375	.941	.708	.563	.914	.875	.903	.500	.905	.734	.750	.899	.671	.438	.917	.000	.648	.944
Automobiles	148	456	18	3	625	44	18	104	7	173	1	466	39	3	509	31	6	6	0	43	1350
% Automobiles	83.6	88.5	46.2	100	85.1	86.3	66.7	74.8	100	77.2	12.5	89.4	83.0	100	87.9	60.8	28.6	54.5	0	51.8	83.3
Trucks	29	59	21	0	109	7	9	35	0	51	7	55	8	0	70	20	15	5	0	40	270
% Trucks	16.4	11.5	53.8	0	14.9	13.7	33.3	25.2	0	22.8	87.5	10.6	17.0	0	12.1	39.2	71.4	45.5	0	48.2	16.7
Buses	0	0	0	0	0	0	0	0	0	0	0	0	0	0	0	0	0	0	0	0	0
% Buses	0	0	0	0	0	0	0	0	0	0	0	0	0	0	0	0	0	0	0	0	0

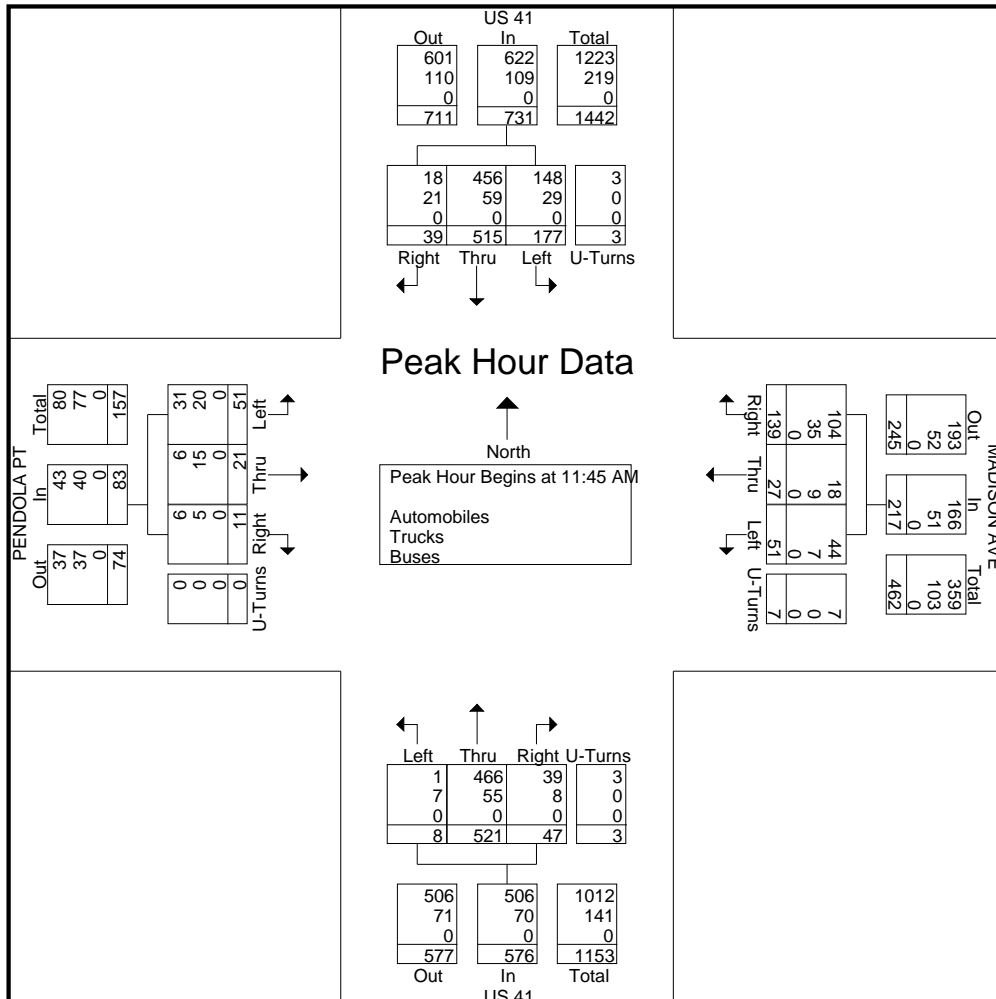



# Southern Traffic Services, Inc.

2911 Westfield Rd  
Gulf Breeze, FL 32563  
1-800-786-3374

*Traffic is our only business!*

US 41 @ Madison Ave  
Tampa, FL

File Name : 13015-9 US 41 @ Madison Ave  
Site Code : 13015-9  
Start Date : 3/7/2013  
Page No : 1

Groups Printed- Automobiles

Start Time	US 41 Southbound				MADISON AVE Westbound				US 41 Northbound				PENDOLA PT Eastbound				Int. Total
	Left	Thru	Right	U-Turns	Left	Thru	Right	U-Turns	Left	Thru	Right	U-Turns	Left	Thru	Right	U-Turns	
09:00 AM	25	85	5	0	5	0	41	3	3	174	8	0	4	0	0	0	353
09:15 AM	19	92	1	0	5	0	27	2	0	162	3	0	0	0	0	0	311
09:30 AM	26	81	3	0	5	1	26	0	0	128	10	0	0	0	0	0	280
09:45 AM	20	88	3	1	8	0	21	0	0	135	10	0	1	0	1	0	288
<b>Total</b>	<b>90</b>	<b>346</b>	<b>12</b>	<b>1</b>	<b>23</b>	<b>1</b>	<b>115</b>	<b>5</b>	<b>3</b>	<b>599</b>	<b>31</b>	<b>0</b>	<b>5</b>	<b>0</b>	<b>1</b>	<b>0</b>	<b>1232</b>
10:00 AM	16	86	0	1	12	1	18	1	0	130	7	0	2	1	2	0	277
10:15 AM	16	68	0	1	4	0	24	0	1	119	6	1	2	0	0	0	242
10:30 AM	23	114	1	0	10	3	27	1	1	103	10	0	4	0	0	0	297
10:45 AM	25	79	0	1	10	2	23	0	3	115	4	0	2	2	2	0	268
<b>Total</b>	<b>80</b>	<b>347</b>	<b>1</b>	<b>3</b>	<b>36</b>	<b>6</b>	<b>92</b>	<b>2</b>	<b>5</b>	<b>467</b>	<b>27</b>	<b>1</b>	<b>10</b>	<b>3</b>	<b>4</b>	<b>0</b>	<b>1084</b>
11:00 AM	21	68	2	0	10	1	23	0	0	120	4	2	5	1	1	0	258
11:15 AM	9	94	6	1	3	2	28	1	0	126	9	0	3	1	0	0	283
11:30 AM	42	119	2	1	3	1	22	1	0	122	6	1	2	1	0	0	323
11:45 AM	49	98	3	0	7	2	25	2	0	118	15	0	13	2	3	0	337
<b>Total</b>	<b>121</b>	<b>379</b>	<b>13</b>	<b>2</b>	<b>23</b>	<b>6</b>	<b>98</b>	<b>4</b>	<b>0</b>	<b>486</b>	<b>34</b>	<b>3</b>	<b>23</b>	<b>5</b>	<b>4</b>	<b>0</b>	<b>1201</b>
12:00 PM	41	112	4	2	12	8	22	2	1	125	9	1	11	1	1	0	352
12:15 PM	27	128	8	0	7	4	25	2	0	107	10	1	3	3	0	0	325
12:30 PM	31	118	3	1	18	4	32	1	0	116	5	1	4	0	2	0	336
12:45 PM	20	108	3	1	8	3	23	1	0	90	9	1	2	0	0	0	269
<b>Total</b>	<b>119</b>	<b>466</b>	<b>18</b>	<b>4</b>	<b>45</b>	<b>19</b>	<b>102</b>	<b>6</b>	<b>1</b>	<b>438</b>	<b>33</b>	<b>4</b>	<b>20</b>	<b>4</b>	<b>3</b>	<b>0</b>	<b>1282</b>
<b>Grand Total</b>	<b>410</b>	<b>1538</b>	<b>44</b>	<b>10</b>	<b>127</b>	<b>32</b>	<b>407</b>	<b>17</b>	<b>9</b>	<b>1990</b>	<b>125</b>	<b>8</b>	<b>58</b>	<b>12</b>	<b>12</b>	<b>0</b>	<b>4799</b>
Apprch %	20.5	76.8	2.2	0.5	21.8	5.5	69.8	2.9	0.4	93.3	5.9	0.4	70.7	14.6	14.6	0	
Total %	8.5	32	0.9	0.2	2.6	0.7	8.5	0.4	0.2	41.5	2.6	0.2	1.2	0.3	0.3	0	



# Southern Traffic Services, Inc.

2911 Westfield Rd  
Gulf Breeze, FL 32563  
1-800-786-3374

*Traffic is our only business!*

US 41 @ Madison Ave  
Tampa, FL

File Name : 13015-9 US 41 @ Madison Ave  
Site Code : 13015-9  
Start Date : 3/7/2013  
Page No : 2

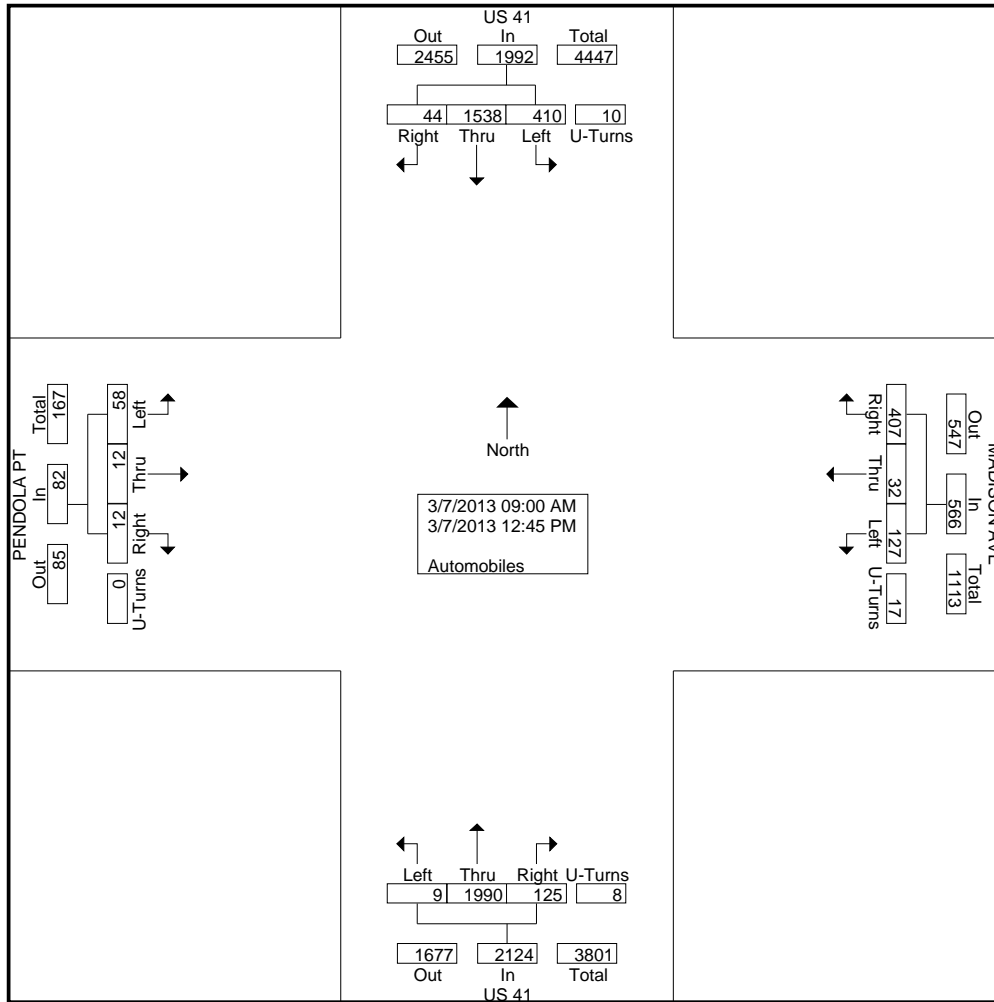



# Southern Traffic Services, Inc.

2911 Westfield Rd  
Gulf Breeze, FL 32563  
1-800-786-3374

*Traffic is our only business!*

US 41 @ Madison Ave  
Tampa, FL

File Name : 13015-9 US 41 @ Madison Ave  
Site Code : 13015-9  
Start Date : 3/7/2013  
Page No : 3

Start Time	US 41 Southbound				MADISON AVE Westbound				US 41 Northbound				PENDOLA PT Eastbound				Int. Total				
	Thru	Right	U-Turns	App. Total	Left	Thru	Right	U-Turns	App. Total	Left	Thru	Right	U-Turns	App. Total	Left	Thru		Right	U-Turns	App. Total	
Peak Hour Analysis From 09:00 AM to 12:45 PM - Peak 1 of 1																					
Peak Hour for Entire Intersection Begins at 11:45 AM																					
11:45 AM	49	98	3	0	150	7	2	25	2	36	0	118	15	0	133	13	2	3	0	18	337
12:00 PM	41	112	4	2	159	12	8	22	2	44	1	125	9	1	136	11	1	1	0	13	352
12:15 PM	27	128	8	0	163	7	4	25	2	38	0	107	10	1	118	3	3	0	0	6	325
12:30 PM	31	118	3	1	153	18	4	32	1	55	0	116	5	1	122	4	0	2	0	6	336
Total Volume	148	456	18	3	625	44	18	104	7	173	1	466	39	3	509	31	6	6	0	43	1350
% App. Total	23.7	73	2.9	0.5		25.4	10.4	60.1	4		0.2	91.6	7.7	0.6		72.1	14	14	0		
PHF	.755	.891	.563	.375	.959	.611	.563	.813	.875	.786	.250	.932	.650	.750	.936	.596	.500	.500	.000	.597	.959

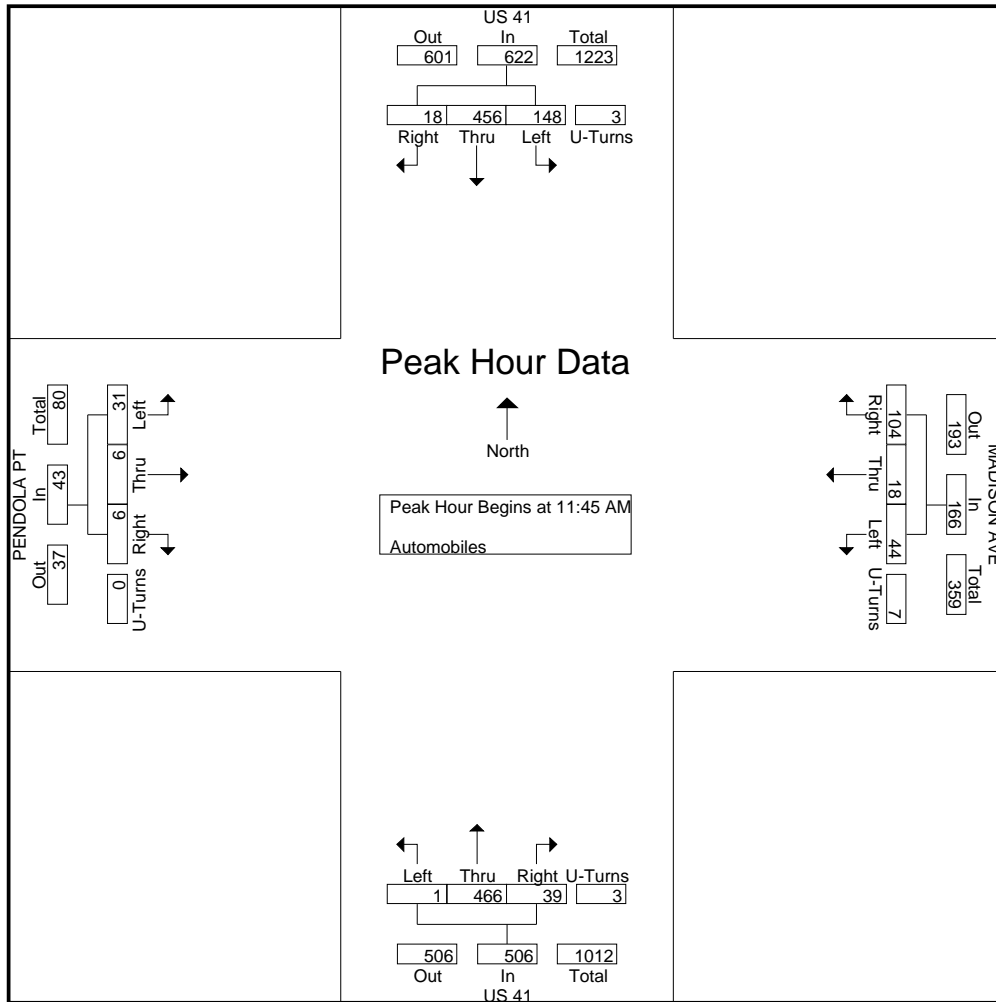



# Southern Traffic Services, Inc.

2911 Westfield Rd  
Gulf Breeze, FL 32563  
1-800-786-3374

*Traffic is our only business!*

US 41 @ Madison Ave  
Tampa, FL

File Name : 13015-9 US 41 @ Madison Ave  
Site Code : 13015-9  
Start Date : 3/7/2013  
Page No : 1

Groups Printed- Trucks - Buses

Start Time	US 41 Southbound				MADISON AVE Westbound				US 41 Northbound				PENDOLA PT Eastbound				Int. Total
	Left	Thru	Right	U-Turns	Left	Thru	Right	U-Turns	Left	Thru	Right	U-Turns	Left	Thru	Right	U-Turns	
09:00 AM	5	20	6	0	5	4	5	0	3	15	0	0	5	5	0	0	73
09:15 AM	5	12	1	0	4	0	10	0	2	11	2	0	4	6	1	0	58
09:30 AM	6	17	10	0	4	1	10	0	1	14	1	0	4	5	0	0	73
09:45 AM	6	15	5	0	1	1	8	0	2	24	4	0	10	1	2	0	79
Total	22	64	22	0	14	6	33	0	8	64	7	0	23	17	3	0	283
10:00 AM	9	13	9	0	5	1	8	0	2	24	1	0	2	5	0	0	79
10:15 AM	4	16	6	0	4	2	6	0	2	16	2	0	3	5	0	0	66
10:30 AM	5	26	6	0	4	1	9	0	4	15	2	0	1	2	0	0	75
10:45 AM	6	22	6	0	2	2	8	0	6	17	2	0	6	1	2	0	80
Total	24	77	27	0	15	6	31	0	14	72	7	0	12	13	2	0	300
11:00 AM	4	8	6	0	6	3	9	0	2	16	1	0	8	3	1	0	67
11:15 AM	3	9	8	0	2	2	6	0	2	18	3	0	5	4	1	0	63
11:30 AM	11	18	4	0	2	2	7	0	0	15	2	0	8	3	1	0	73
11:45 AM	4	8	8	0	3	4	9	0	1	17	1	0	4	10	0	0	69
Total	22	43	26	0	13	11	31	0	5	66	7	0	25	20	3	0	272
12:00 PM	5	19	2	0	2	4	10	0	3	19	3	0	8	1	1	0	77
12:15 PM	12	15	5	0	2	0	10	0	1	5	3	0	3	4	3	0	63
12:30 PM	8	17	6	0	0	1	6	0	2	14	1	0	5	0	1	0	61
12:45 PM	4	20	3	0	2	2	10	0	2	18	4	0	7	1	1	0	74
Total	29	71	16	0	6	7	36	0	8	56	11	0	23	6	6	0	275
Grand Total	97	255	91	0	48	30	131	0	35	258	32	0	83	56	14	0	1130
Apprch %	21.9	57.6	20.5	0	23	14.4	62.7	0	10.8	79.4	9.8	0	54.2	36.6	9.2	0	
Total %	8.6	22.6	8.1	0	4.2	2.7	11.6	0	3.1	22.8	2.8	0	7.3	5	1.2	0	
Trucks	97	254	91	0	48	30	131	0	35	257	32	0	83	56	14	0	1128
% Trucks	100	99.6	100	0	100	100	100	0	100	99.6	100	0	100	100	100	0	99.8
Buses	0	1	0	0	0	0	0	0	0	1	0	0	0	0	0	0	2
% Buses	0	0.4	0	0	0	0	0	0	0	0.4	0	0	0	0	0	0	0.2





# Southern Traffic Services, Inc.

2911 Westfield Rd  
 Gulf Breeze, FL 32563  
 1-800-786-3374

*Traffic is our only business!*

US 41 @ Madison Ave  
 Tampa, FL

File Name : 13015-9 US 41 @ Madison Ave  
 Site Code : 13015-9  
 Start Date : 3/7/2013  
 Page No : 2

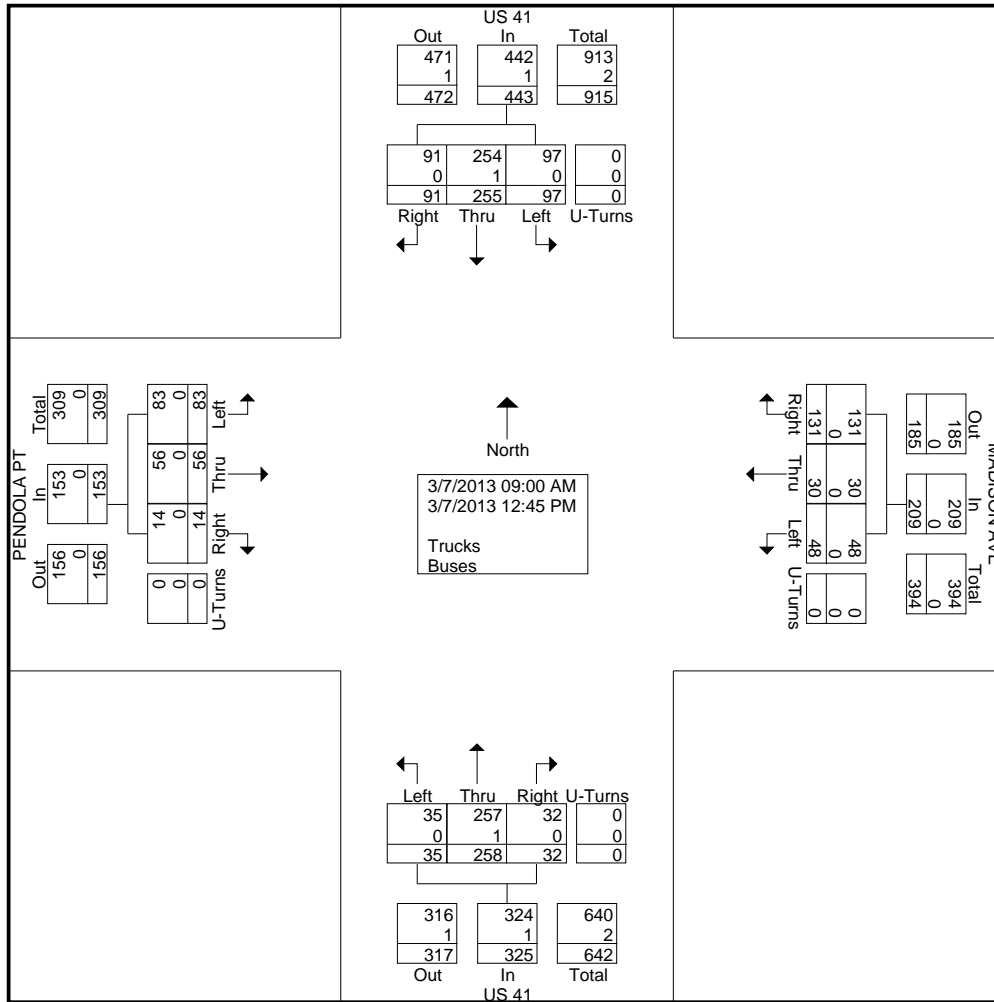



# Southern Traffic Services, Inc.

2911 Westfield Rd  
Gulf Breeze, FL 32563  
1-800-786-3374

*Traffic is our only business!*

US 41 @ Madison Ave  
Tampa, FL

File Name : 13015-9 US 41 @ Madison Ave  
Site Code : 13015-9  
Start Date : 3/7/2013  
Page No : 3

Start Time	US 41 Southbound				MADISON AVE Westbound				US 41 Northbound				PENDOLA PT Eastbound				Int. Total				
	Thru	Right	U-Turns	App. Total	Left	Thru	Right	U-Turns	App. Total	Left	Thru	Right	U-Turns	App. Total	Left	Thru		Right	U-Turns	App. Total	
Peak Hour Analysis From 09:00 AM to 12:45 PM - Peak 1 of 1																					
Peak Hour for Entire Intersection Begins at 10:00 AM																					
10:00 AM	9	13	9	0	31	5	1	8	0	14	2	24	1	0	27	2	5	0	0	7	79
10:15 AM	4	16	6	0	26	4	2	6	0	12	2	16	2	0	20	3	5	0	0	8	66
10:30 AM	5	26	6	0	37	4	1	9	0	14	4	15	2	0	21	1	2	0	0	3	75
10:45 AM	6	22	6	0	34	2	2	8	0	12	6	17	2	0	25	6	1	2	0	9	80
Total Volume	24	77	27	0	128	15	6	31	0	52	14	72	7	0	93	12	13	2	0	27	300
% App. Total	18.8	60.2	21.1	0		28.8	11.5	59.6	0		15.1	77.4	7.5	0		44.4	48.1	7.4	0		
PHF	.667	.740	.750	.000	.865	.750	.750	.861	.000	.929	.583	.750	.875	.000	.861	.500	.650	.250	.000	.750	.938

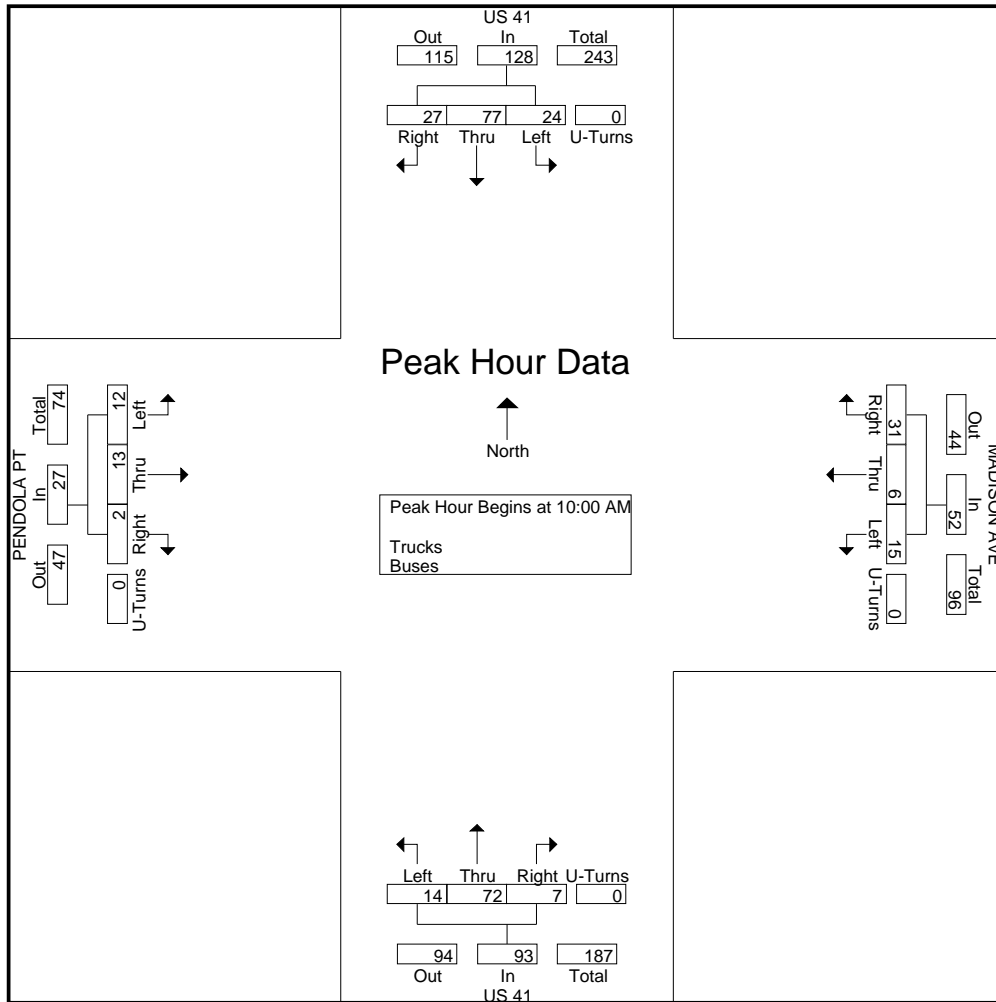



# Southern Traffic Services, Inc.

2911 Westfield Rd  
 Gulf Breeze, FL 32563  
 1-800-786-3374

*Traffic is our only business!*

File Name : 13015-9 US 41 @ Madison Ave Peds

Site Code : 13015-9

Start Date : 3/7/2013

Page No : 1

Groups Printed- Peds

	US 41 Southbound	MADISON AVE Westbound	US 41 Northbound	PENDOLA PT Eastbound	
Start Time	Peds	Peds	Peds	Peds	Int. Total
09:00 AM	0	0	0	0	0
09:15 AM	0	0	1	1	2
09:30 AM	0	0	0	0	0
09:45 AM	1	0	0	0	1
Total	1	0	1	1	3
10:00 AM	0	0	0	0	0
10:15 AM	0	0	0	0	0
10:30 AM	0	0	0	0	0
10:45 AM	0	0	0	0	0
Total	0	0	0	0	0
11:00 AM	0	0	1	0	1
11:15 AM	0	0	0	0	0
11:30 AM	0	0	0	0	0
11:45 AM	1	0	0	0	1
Total	1	0	1	0	2
12:00 PM	0	0	0	0	0
12:15 PM	0	0	0	0	0
12:30 PM	0	0	0	0	0
12:45 PM	0	0	0	0	0
Total	0	0	0	0	0
Grand Total	2	0	2	1	5
Apprch %	100	0	100	100	
Total %	40	0	40	20	





# Southern Traffic Services, Inc.

2911 Westfield Rd  
 Gulf Breeze, FL 32563  
 1-800-786-3374

*Traffic is our only business!*

US 41 @ Port Sutton Rd  
 Tampa, FL

File Name : 13015-10 US 41 @ Port Sutton Rd  
 Site Code : 13015-10  
 Start Date : 3/7/2013  
 Page No : 2

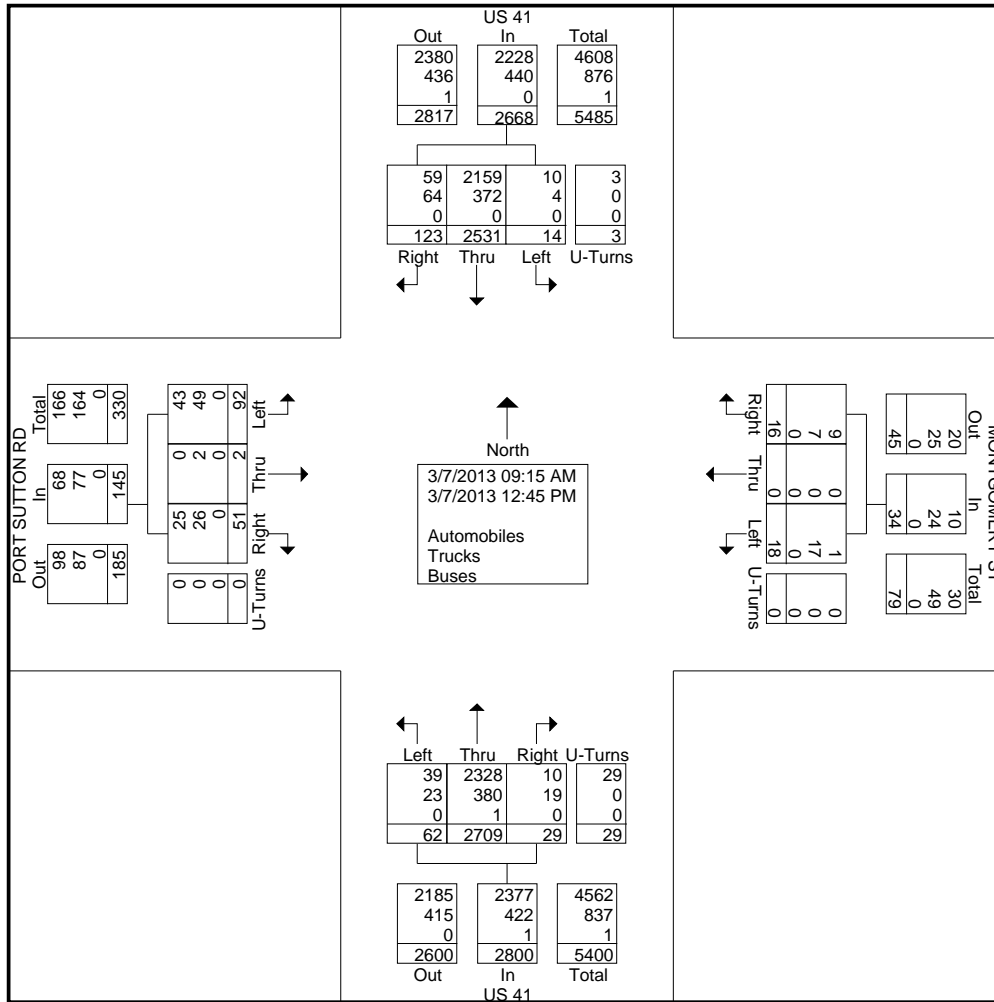



# Southern Traffic Services, Inc.

2911 Westfield Rd  
Gulf Breeze, FL 32563  
1-800-786-3374

*Traffic is our only business!*

US 41 @ Port Sutton Rd  
Tampa, FL

File Name : 13015-10 US 41 @ Port Sutton Rd  
Site Code : 13015-10  
Start Date : 3/7/2013  
Page No : 3

Start Time	US 41 Southbound				MONTGOMERY ST Westbound				US 41 Northbound				PORT SUTTON RD Eastbound				Int. Total				
	Thru	Right	U-Turns	App. Total	Left	Thru	Right	U-Turns	App. Total	Left	Thru	Right	U-Turns	App. Total	Left	Thru		Right	U-Turns	App. Total	
Peak Hour Analysis From 09:15 AM to 12:45 PM - Peak 1 of 1																					
Peak Hour for Entire Intersection Begins at 11:30 AM																					
11:30 AM	3	241	12	1	257	0	0	3	0	3	0	176	1	0	177	4	0	2	0	6	443
11:45 AM	0	182	8	0	190	1	0	3	0	4	2	179	4	1	186	7	0	2	0	9	389
12:00 PM	0	157	9	0	166	0	0	0	0	0	6	149	4	6	165	7	0	6	0	13	344
12:15 PM	0	189	8	0	197	1	0	2	0	3	4	190	3	4	201	10	1	8	0	19	420
Total Volume	3	769	37	1	810	2	0	8	0	10	12	694	12	11	729	28	1	18	0	47	1596
% App. Total	0.4	94.9	4.6	0.1		20	0	80	0		1.6	95.2	1.6	1.5		59.6	2.1	38.3	0		
PHF	.250	.798	.771	.250	.788	.500	.000	.667	.000	.625	.500	.913	.750	.458	.907	.700	.250	.563	.000	.618	.901
Automobiles	2	675	20	1	698	0	0	2	0	2	8	591	6	11	616	15	0	9	0	24	1340
% Automobiles	66.7	87.8	54.1	100	86.2	0	0	25.0	0	20.0	66.7	85.2	50.0	100	84.5	53.6	0	50.0	0	51.1	84.0
Trucks	1	94	17	0	112	2	0	6	0	8	4	102	6	0	112	13	1	9	0	23	255
% Trucks	33.3	12.2	45.9	0	13.8	100	0	75.0	0	80.0	33.3	14.7	50.0	0	15.4	46.4	100	50.0	0	48.9	16.0
Buses	0	0	0	0	0	0	0	0	0	0	0	1	0	0	1	0	0	0	0	0	1
% Buses	0	0	0	0	0	0	0	0	0	0	0	0.1	0	0	0.1	0	0	0	0	0	0.1

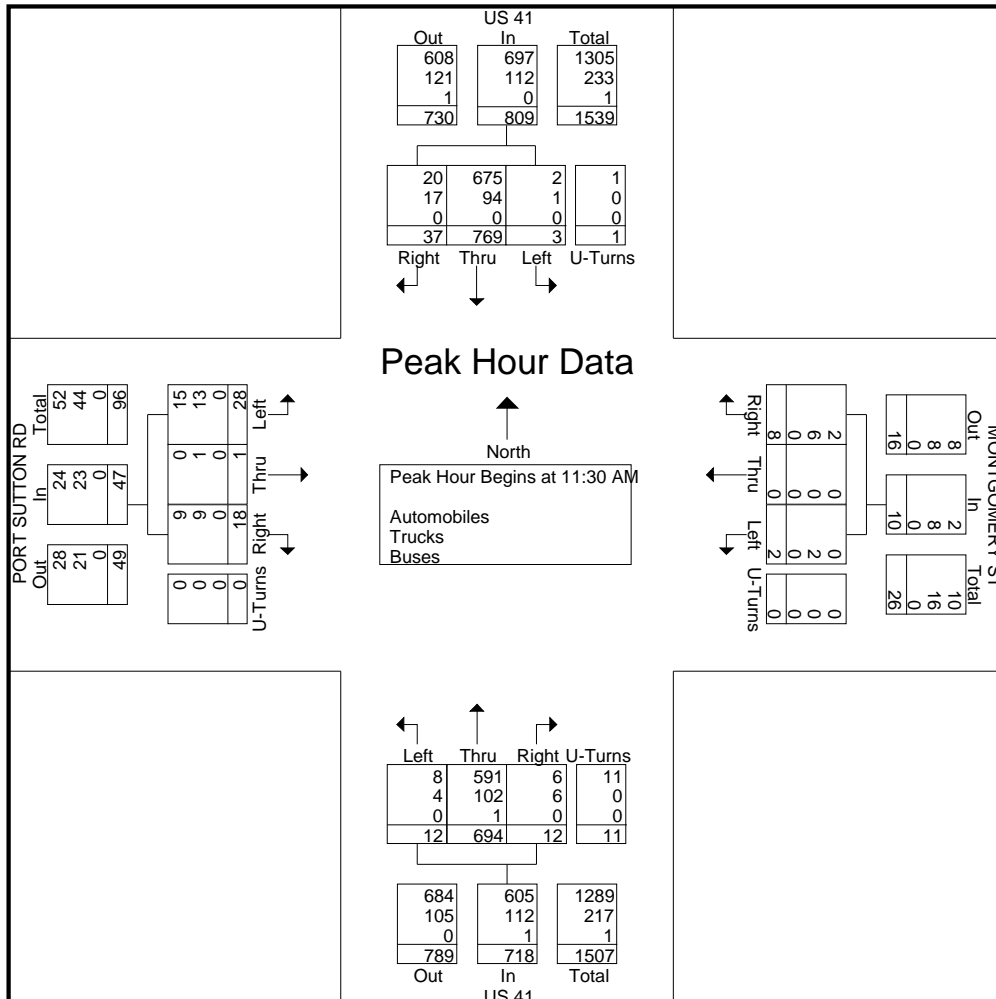



# Southern Traffic Services, Inc.

2911 Westfield Rd  
 Gulf Breeze, FL 32563  
 1-800-786-3374

*Traffic is our only business!*

US 41 @ Port Sutton Rd  
 Tampa, FL

File Name : 13015-10 US 41 @ Port Sutton Rd  
 Site Code : 13015-10  
 Start Date : 3/7/2013  
 Page No : 1

Groups Printed- Automobiles

Start Time	US 41 Southbound				MONTGOMERY ST Westbound				US 41 Northbound				PORT SUTTON RD Eastbound				Int. Total
	Left	Thru	Right	U-Turns	Left	Thru	Right	U-Turns	Left	Thru	Right	U-Turns	Left	Thru	Right	U-Turns	
09:15 AM	1	105	5	1	0	0	0	0	3	221	0	1	3	0	1	0	341
09:30 AM	1	121	3	0	0	0	0	0	1	164	0	2	2	0	1	0	295
09:45 AM	0	126	2	0	1	0	0	0	1	173	2	0	1	0	0	0	306
Total	2	352	10	1	1	0	0	0	5	558	2	3	6	0	2	0	942
10:00 AM	1	96	0	0	0	0	0	0	2	154	0	2	4	0	1	0	260
10:15 AM	0	137	2	0	0	0	0	0	1	138	0	1	0	0	4	0	283
10:30 AM	2	140	5	0	0	0	2	0	1	142	0	1	2	0	2	0	297
10:45 AM	0	149	1	0	0	0	1	0	2	159	1	4	4	0	3	0	324
Total	3	522	8	0	0	0	3	0	6	593	1	8	10	0	10	0	1164
11:00 AM	0	138	5	1	0	0	1	0	1	152	1	2	3	0	3	0	307
11:15 AM	0	154	2	0	0	0	0	0	6	139	0	2	1	0	1	0	305
11:30 AM	2	209	3	1	0	0	0	0	0	156	0	0	2	0	2	0	375
11:45 AM	0	161	4	0	0	0	1	0	1	152	2	1	4	0	1	0	327
Total	2	662	14	2	0	0	2	0	8	599	3	5	10	0	7	0	1314
12:00 PM	0	135	6	0	0	0	0	0	4	119	3	6	3	0	2	0	278
12:15 PM	0	170	7	0	0	0	1	0	3	164	1	4	6	0	4	0	360
12:30 PM	2	178	6	0	0	0	3	0	3	168	0	1	6	0	0	0	367
12:45 PM	1	140	8	0	0	0	0	0	10	127	0	2	2	0	0	0	290
Total	3	623	27	0	0	0	4	0	20	578	4	13	17	0	6	0	1295
Grand Total	10	2159	59	3	1	0	9	0	39	2328	10	29	43	0	25	0	4715
Apprch %	0.4	96.8	2.6	0.1	10	0	90	0	1.6	96.8	0.4	1.2	63.2	0	36.8	0	
Total %	0.2	45.8	1.3	0.1	0	0	0.2	0	0.8	49.4	0.2	0.6	0.9	0	0.5	0	



# Southern Traffic Services, Inc.

2911 Westfield Rd  
Gulf Breeze, FL 32563  
1-800-786-3374

*Traffic is our only business!*

US 41 @ Port Sutton Rd  
Tampa, FL

File Name : 13015-10 US 41 @ Port Sutton Rd  
Site Code : 13015-10  
Start Date : 3/7/2013  
Page No : 2

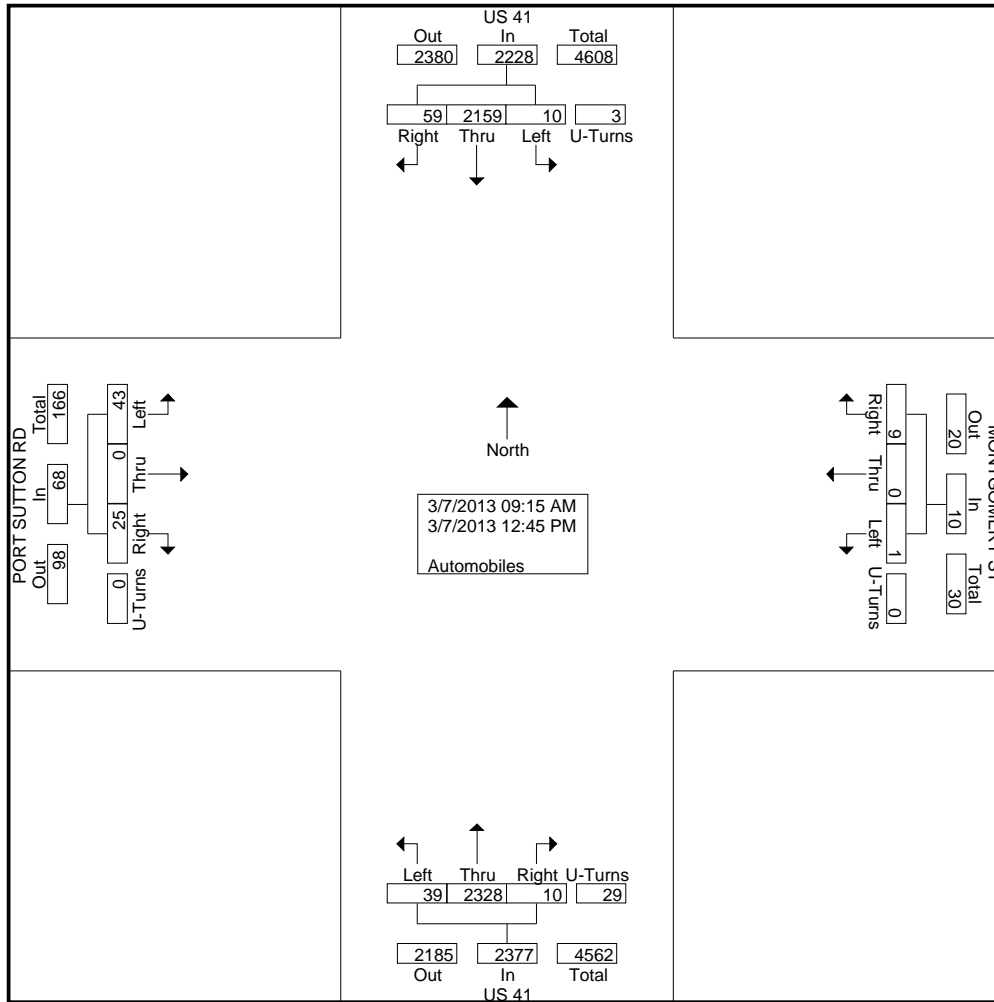





# Southern Traffic Services, Inc.

2911 Westfield Rd  
Gulf Breeze, FL 32563  
1-800-786-3374

*Traffic is our only business!*

US 41 @ Port Sutton Rd  
Tampa, FL

File Name : 13015-10 US 41 @ Port Sutton Rd  
Site Code : 13015-10  
Start Date : 3/7/2013  
Page No : 3

Start Time	US 41 Southbound				MONTGOMERY ST Westbound				US 41 Northbound				PORT SUTTON RD Eastbound				Int. Total				
	Thru	Right	U-Turns	App. Total	Left	Thru	Right	U-Turns	App. Total	Left	Thru	Right	U-Turns	App. Total	Left	Thru		Right	U-Turns	App. Total	
Peak Hour Analysis From 09:15 AM to 12:45 PM - Peak 1 of 1																					
Peak Hour for Entire Intersection Begins at 11:30 AM																					
11:30 AM	2	209	3	1	215	0	0	0	0	0	0	156	0	0	156	2	0	2	0	4	375
11:45 AM	0	161	4	0	165	0	0	1	0	1	1	152	2	1	156	4	0	1	0	5	327
12:00 PM	0	135	6	0	141	0	0	0	0	0	4	119	3	6	132	3	0	2	0	5	278
12:15 PM	0	170	7	0	177	0	0	1	0	1	3	164	1	4	172	6	0	4	0	10	360
Total Volume	2	675	20	1	698	0	0	2	0	2	8	591	6	11	616	15	0	9	0	24	1340
% App. Total	0.3	96.7	2.9	0.1		0	0	100	0		1.3	95.9	1	1.8		62.5	0	37.5	0		
PHF	.250	.807	.714	.250	.812	.000	.000	.500	.000	.500	.500	.901	.500	.458	.895	.625	.000	.563	.000	.600	.893

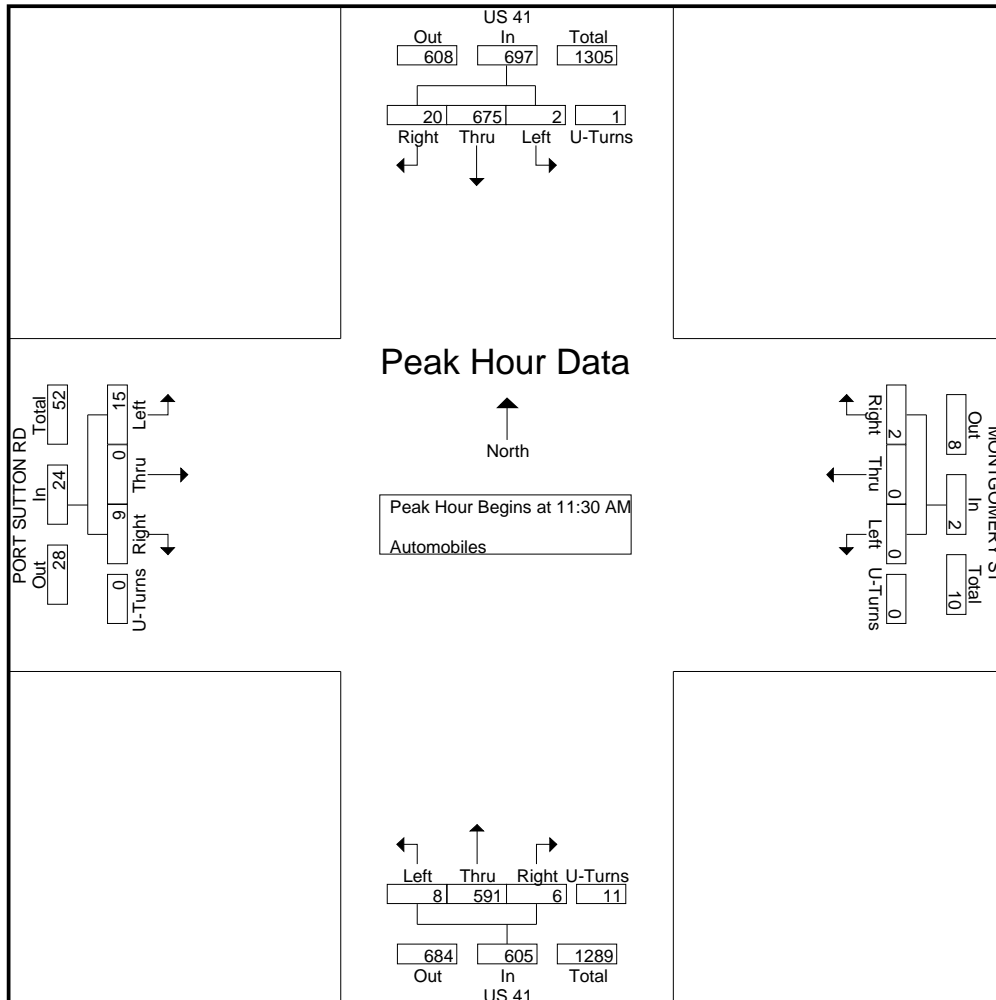



# Southern Traffic Services, Inc.

2911 Westfield Rd  
Gulf Breeze, FL 32563  
1-800-786-3374

*Traffic is our only business!*

US 41 @ Port Sutton Rd  
Tampa, FL

File Name : 13015-10 US 41 @ Port Sutton Rd  
Site Code : 13015-10  
Start Date : 3/7/2013  
Page No : 1

Groups Printed- Trucks - Buses

Start Time	US 41 Southbound				MONTGOMERY ST Westbound				US 41 Northbound				PORT SUTTON RD Eastbound				Int. Total
	Left	Thru	Right	U-Turns	Left	Thru	Right	U-Turns	Left	Thru	Right	U-Turns	Left	Thru	Right	U-Turns	
09:15 AM	0	15	5	0	0	0	0	0	3	22	2	0	2	0	0	0	49
09:30 AM	2	31	2	0	3	0	0	0	5	21	1	0	3	0	1	0	69
09:45 AM	0	21	5	0	0	0	0	0	2	27	1	0	5	0	2	0	63
Total	2	67	12	0	3	0	0	0	10	70	4	0	10	0	3	0	181
10:00 AM	0	24	2	0	3	0	0	0	3	31	1	0	2	0	2	0	68
10:15 AM	0	22	3	0	1	0	0	0	1	24	0	0	4	0	2	0	57
10:30 AM	0	29	7	0	1	0	0	0	0	23	3	0	2	0	4	0	69
10:45 AM	0	30	4	0	1	0	0	0	0	32	0	0	4	0	2	0	73
Total	0	105	16	0	6	0	0	0	4	110	4	0	12	0	10	0	267
11:00 AM	0	26	5	0	1	0	0	0	1	26	2	0	3	1	2	0	67
11:15 AM	0	25	3	0	1	0	0	0	3	24	0	0	6	0	1	0	63
11:30 AM	1	32	9	0	0	0	3	0	0	20	1	0	2	0	0	0	68
11:45 AM	0	21	4	0	1	0	2	0	1	27	2	0	3	0	1	0	62
Total	1	104	21	0	3	0	5	0	5	97	5	0	14	1	4	0	260
12:00 PM	0	22	3	0	0	0	0	0	2	30	1	0	4	0	4	0	66
12:15 PM	0	19	1	0	1	0	1	0	1	26	2	0	4	1	4	0	60
12:30 PM	0	31	5	0	2	0	0	0	1	20	0	0	4	0	0	0	63
12:45 PM	1	24	6	0	2	0	1	0	0	28	3	0	1	0	1	0	67
Total	1	96	15	0	5	0	2	0	4	104	6	0	13	1	9	0	256
Grand Total	4	372	64	0	17	0	7	0	23	381	19	0	49	2	26	0	964
Apprch %	0.9	84.5	14.5	0	70.8	0	29.2	0	5.4	90.1	4.5	0	63.6	2.6	33.8	0	
Total %	0.4	38.6	6.6	0	1.8	0	0.7	0	2.4	39.5	2	0	5.1	0.2	2.7	0	
Trucks	4	372	64	0	17	0	7	0	23	380	19	0	49	2	26	0	963
% Trucks	100	100	100	0	100	0	100	0	100	99.7	100	0	100	100	100	0	99.9
Buses	0	0	0	0	0	0	0	0	0	1	0	0	0	0	0	0	1
% Buses	0	0	0	0	0	0	0	0	0	0.3	0	0	0	0	0	0	0.1



# Southern Traffic Services, Inc.

2911 Westfield Rd  
 Gulf Breeze, FL 32563  
 1-800-786-3374

*Traffic is our only business!*

US 41 @ Port Sutton Rd  
 Tampa, FL

File Name : 13015-10 US 41 @ Port Sutton Rd  
 Site Code : 13015-10  
 Start Date : 3/7/2013  
 Page No : 2

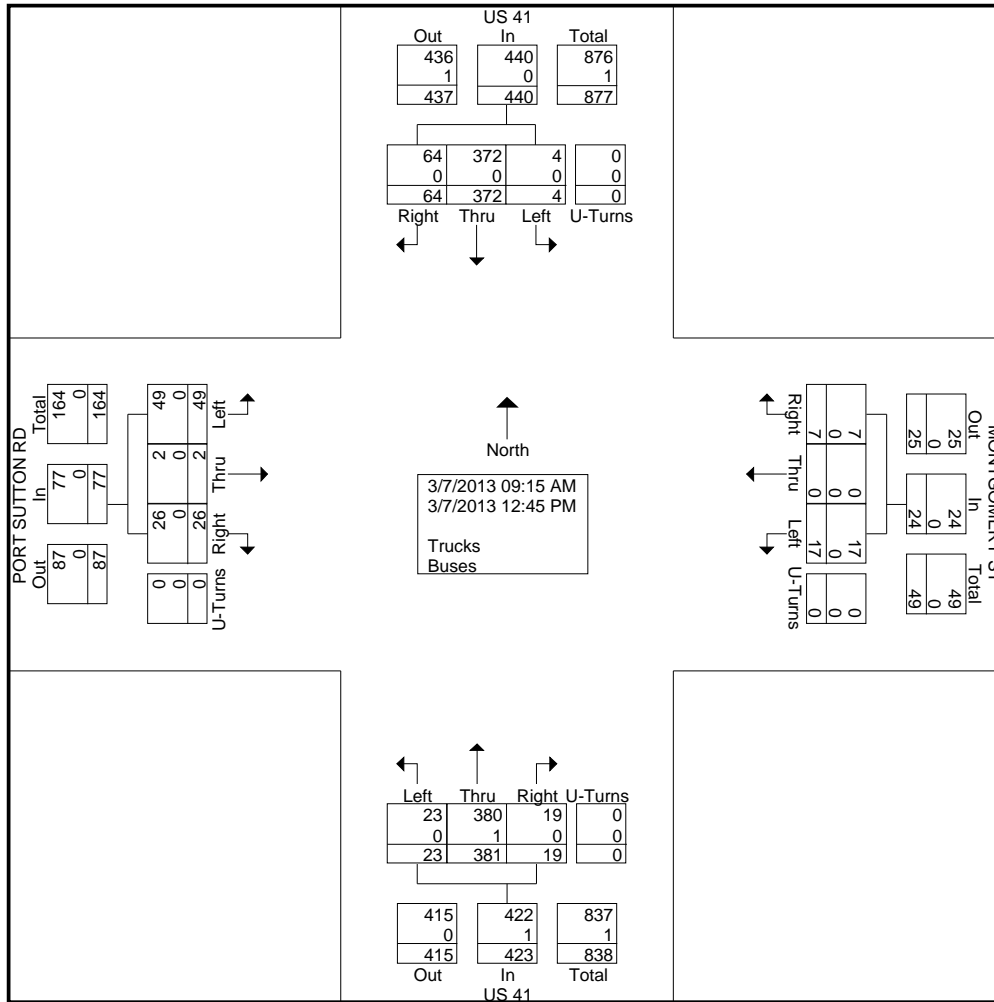



# Southern Traffic Services, Inc.

2911 Westfield Rd  
Gulf Breeze, FL 32563  
1-800-786-3374

*Traffic is our only business!*

US 41 @ Port Sutton Rd  
Tampa, FL

File Name : 13015-10 US 41 @ Port Sutton Rd  
Site Code : 13015-10  
Start Date : 3/7/2013  
Page No : 3

Start Time	US 41 Southbound				MONTGOMERY ST Westbound				US 41 Northbound				PORT SUTTON RD Eastbound				Int. Total				
	Thru	Right	U-Turns	App. Total	Left	Thru	Right	U-Turns	App. Total	Left	Thru	Right	U-Turns	App. Total	Left	Thru		Right	U-Turns	App. Total	
Peak Hour Analysis From 09:15 AM to 12:45 PM - Peak 1 of 1																					
Peak Hour for Entire Intersection Begins at 10:30 AM																					
10:30 AM	0	29	7	0	36	1	0	0	0	1	0	23	3	0	26	2	0	4	0	6	69
10:45 AM	0	30	4	0	34	1	0	0	0	1	0	32	0	0	32	4	0	2	0	6	73
11:00 AM	0	26	5	0	31	1	0	0	0	1	1	26	2	0	29	3	1	2	0	6	67
11:15 AM	0	25	3	0	28	1	0	0	0	1	3	24	0	0	27	6	0	1	0	7	63
Total Volume	0	110	19	0	129	4	0	0	0	4	4	105	5	0	114	15	1	9	0	25	272
% App. Total	0	85.3	14.7	0	100	0	0	0	0	100	3.5	92.1	4.4	0	100	60	4	36	0	100	272
PHF	.000	.917	.679	.000	.896	1.00	.000	.000	.000	1.00	.333	.820	.417	.000	.891	.625	.250	.563	.000	.893	.932

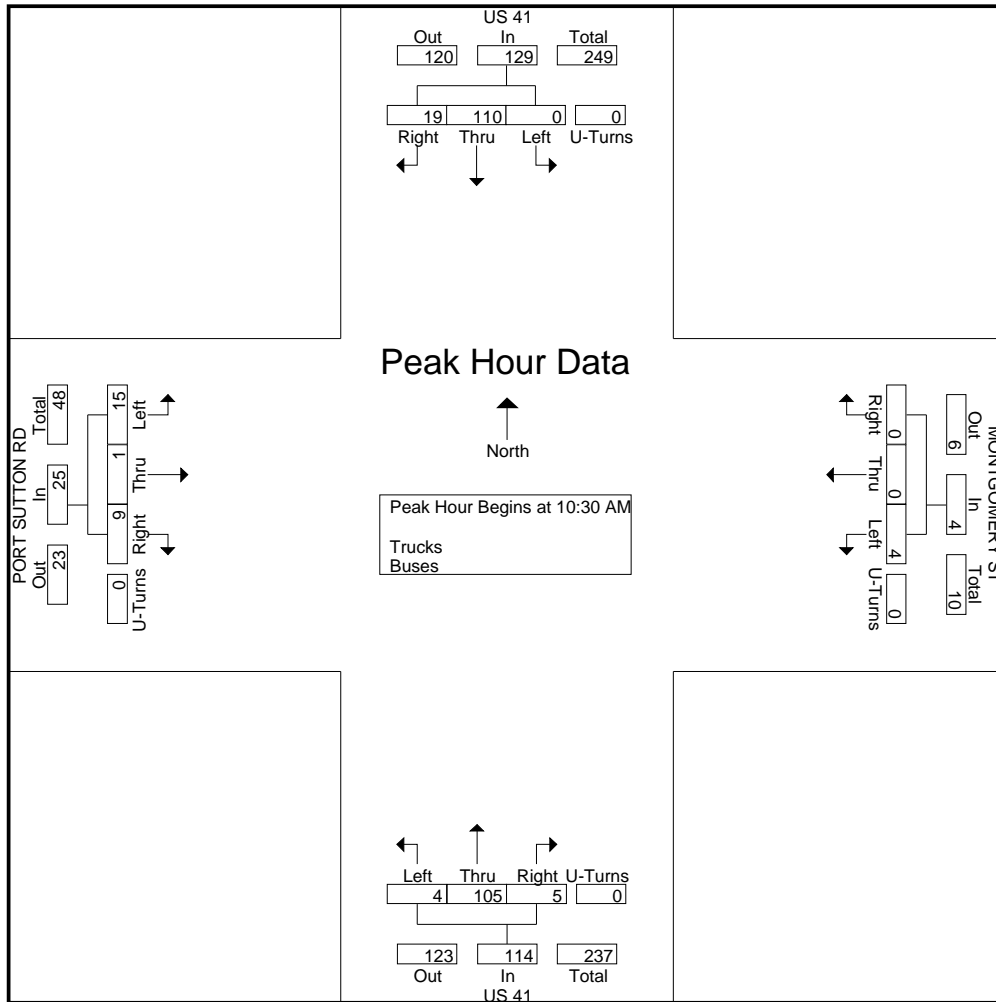



# Southern Traffic Services, Inc.

2911 Westfield Rd  
 Gulf Breeze, FL 32563  
 1-800-786-3374

*Traffic is our only business!*

File Name : 13015-10 US 41 @ Port Sutton Rd Peds

Site Code : 13015-10

Start Date : 3/7/2013

Page No : 1

Groups Printed- Peds

	US 41 Southbound	MONTGOMERY ST Westbound	US 41 Northbound	PORT SUTTON RD Eastbound	Int. Total
Start Time	Peds	Peds	Peds	Peds	
09:15 AM	0	0	0	0	0
09:30 AM	0	0	0	0	0
09:45 AM	0	0	0	0	0
Total	0	0	0	0	0
10:00 AM	0	0	0	0	0
10:15 AM	0	0	0	0	0
10:30 AM	0	0	0	0	0
10:45 AM	0	0	0	0	0
Total	0	0	0	0	0
11:00 AM	0	0	0	0	0
11:15 AM	1	0	0	0	1
11:30 AM	0	0	1	0	1
11:45 AM	1	0	0	0	1
Total	2	0	1	0	3
12:00 PM	0	0	0	0	0
12:15 PM	0	0	0	0	0
12:30 PM	0	0	0	0	0
12:45 PM	0	0	0	0	0
Total	0	0	0	0	0
Grand Total	2	0	1	0	3
Apprch %	100	0	100	0	
Total %	66.7	0	33.3	0	

## **72-HOUR CLASSIFICATION COUNTS**

## Traffic Count Data

Finance Number:  
 Location Code: 2  
 Count Location US 41 Between Kracker Avenue and Gibsonton Drive

TYPE OF COUNT: 72 Hour Class Classification Count

TIME OF COUNT:

Start Date:	1/8/2013	Start Time:	Midnight
End Date:	1/10/2013	End Time:	Midnight

VOLUMES:

Average Daily:	24,339	Peak Hour Start Time:	5:00 PM
Daily Truck Average:	2,072	Average Peak Hour:	2,230
		Max Hour Truck Average:	171
		Peak Hour Truck Average:	104

TRAVEL CHARACTERISTICS:

K MEASURED		D MEASURED	
K=	9%	D=	66%
T Max Hour	12%	T Daily	9%
T med (max)	5%	T med Daily	3%
T heavy (max)	7%	T heavy Daily	5%
T peak Hour	5%		
T med Peak Hour	3%	Axle Factor	0.95
T heavy Peak Hour	2%		

## Southern Traffic Services, Inc. Class Speed Matrix

**US 41 between Kracker Avenue & Gibsonton Drive**

**Northbound**

**27.82820 , -82.38197**

**Datasets:**

**Site:** [13] !9024  
**Site:** [13] !C7040  
**Direction:** 1 - North bound, A hit first., **Lane:** 1  
**Survey Duration:** 7:56 Monday, January 07, 2013 => 10:42 Friday, January 11, 2013  
**File:** G:\DATA\2013\Private\13015\marco\Jan -11-2013 DATA\UM13 NB Slow.eco (Plus)  
**Identifier:** U345XNKN MC56-L5 [MC55] (c)Microcom 19Oct04  
**Algorithm:** Factory default  
**Data type:** Axle sensors - Paired (Class, Speed, Count)

**Profile:**

**Filter time:** 0:00 Tuesday, January 08, 2013 => 0:00 Friday, January 11, 2013  
**Included classes:** 1, 2, 3, 4, 5, 6, 7, 8, 9, 10, 11, 12, 13, 14  
**Speed range:** 0 - 100 mph.  
**Direction:** North (bound)

**Speed (mph)**

**Speed Totals**

	Class															
	1	2	3	4	5	6	7	8	9	10	11	12	13	14		
0 - 5	.	1	.	.	.	.	.	.	.	.	.	.	.	.	1	0.0%
5 - 10	1	8	.	.	1	.	.	.	.	.	.	.	.	.	10	0.0%
10 - 15	5	19	2	.	.	1	.	.	.	.	.	.	.	.	27	0.1%
15 - 20	3	25	10	.	2	.	.	1	.	.	.	.	.	.	41	0.1%
20 - 25	.	48	13	.	3	4	.	3	.	.	.	.	.	.	71	0.2%
25 - 30	1	137	43	.	8	5	.	2	6	.	.	.	.	.	202	0.6%
30 - 35	2	351	170	.	37	16	.	11	9	.	.	.	1	.	597	1.6%
35 - 40	16	888	422	4	67	40	5	31	12	1	.	.	.	.	1486	4.1%
40 - 45	16	1532	684	4	108	103	8	49	44	.	.	.	.	.	2548	7.0%
45 - 50	35	3264	1350	14	191	150	20	164	136	8	.	.	3	.	5335	14.7%
50 - 55	95	6270	2529	17	305	174	19	212	227	14	.	.	6	.	9868	27.2%
55 - 60	125	6967	2575	9	251	126	7	150	138	5	.	.	3	.	10356	28.5%
60 - 65	94	3263	1086	.	79	28	.	38	30	2	.	.	.	.	4620	12.7%
65 - 70	25	661	226	.	19	4	.	4	5	2	.	.	.	.	946	2.6%
70 - 75	10	107	34	.	2	1	.	.	.	.	.	.	.	.	154	0.4%
75 - 80	1	12	6	.	.	.	.	.	.	.	.	.	.	.	19	0.1%
80 - 85	1	1	2	.	.	.	.	.	.	.	.	.	.	.	4	0.0%
85 - 90	.	1	.	.	.	.	.	.	.	.	.	.	.	.	1	0.0%
90 - 95	.	.	.	.	.	.	.	.	.	.	.	.	.	.	0	0.0%
95 - 100	.	.	.	.	.	.	.	.	.	.	.	.	.	.	0	0.0%
	<b>430</b>	<b>23555</b>	<b>9152</b>	<b>48</b>	<b>1073</b>	<b>652</b>	<b>59</b>	<b>665</b>	<b>607</b>	<b>32</b>	<b>0</b>	<b>0</b>	<b>13</b>	<b>0</b>	<b>36286</b>	
	<b>1.2%</b>	<b>64.9%</b>	<b>25.2%</b>	<b>0.1%</b>	<b>3.0%</b>	<b>1.8%</b>	<b>0.2%</b>	<b>1.8%</b>	<b>1.7%</b>	<b>0.1%</b>	<b>0.0%</b>	<b>0.0%</b>	<b>0.0%</b>	<b>0.0%</b>		
	<b>Class Totals</b>															



# Southern Traffic Services, Inc.

## Vehicle Counts

**US 41 between Kracker Avenue & Gibsonton Drive**

**Northbound**

**27.82820 , -82.38197**

**Datasets:**

**Site:** [13] !9024  
**Site:** [13] !C7040  
**Direction:** 1 - North bound, A hit first., **Lane:** 1  
**Survey Duration:** 7:56 Monday, January 07, 2013 => 10:42 Friday, January 11, 2013  
**File:** G:\DATA\2013\Private\13015\marco\Jan -11-2013 DATA\UM13 NB Slow.eco (Plus)  
**Identifier:** U345XNKN MC56-L5 [MC55] (c)Microcom 19Oct04  
**Algorithm:** Factory default  
**Data type:** Axle sensors - Paired (Class, Speed, Count)

**Profile:**

**Filter time:** 0:00 Tuesday, January 08, 2013 => 0:00 Friday, January 11, 2013  
**Included classes:** 1, 2, 3, 4, 5, 6, 7, 8, 9, 10, 11, 12, 13, 14  
**Speed range:** 0 - 100 mph.  
**Direction:** North (bound)  
**Separation:** All - (Headway)  
**Name:** Factory default profile  
**Scheme:** Vehicle classification (FLDOT)  
**Units:** Non metric (ft, mi, ft/s, mph, lb, ton)  
**In profile:** Vehicles = 36286

**Tuesday, January 08, 2013 - Total=12031, 15 minute drops**

0000	0100	0200	0300	0400	0500	0600	0700	0800	0900	1000	1100	1200	1300	1400	1500	1600	1700	1800	1900	2000	2100	2200	2300	
<b>40</b>	<b>28</b>	<b>19</b>	<b>53</b>	<b>135</b>	<b>478</b>	<b>1182</b>	<b>1518</b>	<b>982</b>	<b>665</b>	<b>569</b>	<b>605</b>	<b>637</b>	<b>644</b>	<b>725</b>	<b>822</b>	<b>735</b>	<b>773</b>	<b>515</b>	<b>305</b>	<b>216</b>	<b>170</b>	<b>123</b>	<b>92</b>	
10	8	5	15	17	75	229	383	299	146	135	167	133	158	159	200	181	186	140	91	41	46	35	24	15
11	9	4	14	23	113	294	370	267	170	147	164	167	172	193	190	160	216	156	96	51	43	34	31	21
13	7	5	15	40	134	288	399	221	182	154	131	168	162	198	247	195	198	128	76	65	42	26	30	17
6	4	5	9	55	156	371	366	195	167	133	143	169	152	175	185	199	173	91	42	59	39	28	7	11

**AM Peak 0645 - 0745 (1523), AM PHF=0.95 PM Peak 1500 - 1600 (822), PM PHF=0.83**

**Wednesday, January 09, 2013 - Total=12156, 15 minute drops**

0000	0100	0200	0300	0400	0500	0600	0700	0800	0900	1000	1100	1200	1300	1400	1500	1600	1700	1800	1900	2000	2100	2200	2300	
<b>64</b>	<b>31</b>	<b>33</b>	<b>55</b>	<b>125</b>	<b>530</b>	<b>1116</b>	<b>1519</b>	<b>975</b>	<b>708</b>	<b>613</b>	<b>576</b>	<b>628</b>	<b>636</b>	<b>696</b>	<b>808</b>	<b>725</b>	<b>774</b>	<b>560</b>	<b>307</b>	<b>242</b>	<b>222</b>	<b>130</b>	<b>83</b>	
15	7	8	15	17	88	201	357	311	196	148	144	142	184	167	198	185	214	166	108	58	75	43	29	16
21	11	7	16	33	101	298	366	255	157	167	137	161	142	175	158	168	206	142	75	78	56	31	15	15
17	8	10	13	31	153	307	416	214	180	144	145	158	155	191	257	189	195	115	67	51	46	30	21	4
11	5	8	11	44	188	310	380	195	175	154	150	167	155	163	195	183	159	137	57	55	45	26	18	7

**AM Peak 0700 - 0800 (1519), AM PHF=0.91 PM Peak 1500 - 1600 (808), PM PHF=0.79**

**Thursday, January 10, 2013 - Total=12099, 15 minute drops**

0000	0100	0200	0300	0400	0500	0600	0700	0800	0900	1000	1100	1200	1300	1400	1500	1600	1700	1800	1900	2000	2100	2200	2300	
<b>42</b>	<b>38</b>	<b>25</b>	<b>42</b>	<b>129</b>	<b>496</b>	<b>1130</b>	<b>1535</b>	<b>988</b>	<b>632</b>	<b>579</b>	<b>641</b>	<b>612</b>	<b>625</b>	<b>697</b>	<b>833</b>	<b>722</b>	<b>723</b>	<b>570</b>	<b>327</b>	<b>296</b>	<b>199</b>	<b>135</b>	<b>83</b>	
16	7	6	11	22	77	204	368	319	168	146	153	144	149	168	170	180	190	179	87	60	48	37	21	14
15	9	8	14	29	98	254	355	268	150	159	167	153	157	173	198	174	195	138	95	89	59	36	20	16
4	16	5	9	32	149	364	463	214	178	36	157	156	164	200	264	187	185	128	66	71	46	33	30	11
7	6	6	8	46	172	308	349	187	136	238	164	159	155	156	201	181	153	125	79	76	46	29	12	10

**AM Peak 0700 - 0800 (1535), AM PHF=0.83 PM Peak 1515 - 1615 (843), PM PHF=0.80**

# Southern Traffic Services, Inc.

## Classification Count

**US 41 between Kracker Avenue & Gibsonton Drive**

**Northbound**

**27.82820 , -82.38197**

**Datasets:**

**Site:** [13] !9024  
**Site:** [13] !C7040  
**Direction:** 1 - North bound, A hit first., **Lane:** 1  
**Survey Duration:** 7:56 Monday, January 07, 2013 => 10:42 Friday, January 11, 2013  
**File:** G:\DATA\2013\Private\13015\marco\Jan -11-2013 DATA\UM13 NB Slow.eco (Plus)  
**Identifier:** U345XNKN MC56-L5 [MC55] (c)Microcom 19Oct04  
**Algorithm:** Factory default  
**Data type:** Axle sensors - Paired (Class, Speed, Count)

**Profile:**

**Filter time:** 0:00 Tuesday, January 08, 2013 => 0:00 Friday, January 11, 2013  
**Included classes:** 1, 2, 3, 4, 5, 6, 7, 8, 9, 10, 11, 12, 13, 14  
**Speed range:** 0 - 100 mph.  
**Direction:** North (bound)

**Tuesday, January 08, 2013**

Time	Total	Cls 1	Cls 2	Cls 3	Cls 4	Cls 5	Cls 6	Cls 7	Cls 8	Cls 9	Cls 10	Cls 11	Cls 12	Cls 13	Cls 14
0000	10	0	7	3	0	0	0	0	0	0	0	0	0	0	0
0015	11	0	9	1	0	0	0	0	0	1	0	0	0	0	0
0030	13	0	5	7	0	0	0	0	0	1	0	0	0	0	0
0045	6	0	3	1	0	1	0	0	0	1	0	0	0	0	0
0100	8	0	4	4	0	0	0	0	0	0	0	0	0	0	0
0115	9	0	9	0	0	0	0	0	0	0	0	0	0	0	0
0130	7	0	4	2	0	0	0	0	0	1	0	0	0	0	0
0145	4	0	4	0	0	0	0	0	0	0	0	0	0	0	0
0200	5	0	4	0	0	0	0	0	0	1	0	0	0	0	0
0215	4	0	4	0	0	0	0	0	0	0	0	0	0	0	0
0230	5	0	4	1	0	0	0	0	0	0	0	0	0	0	0
0245	5	0	3	2	0	0	0	0	0	0	0	0	0	0	0
0300	15	0	12	2	0	0	0	0	1	0	0	0	0	0	0
0315	14	0	8	5	0	1	0	0	0	0	0	0	0	0	0
0330	15	0	10	5	0	0	0	0	0	0	0	0	0	0	0
0345	9	0	8	0	0	0	0	0	0	1	0	0	0	0	0
0400	17	0	12	4	0	0	1	0	0	0	0	0	0	0	0
0415	23	0	16	7	0	0	0	0	0	0	0	0	0	0	0
0430	40	0	28	8	0	0	2	0	0	2	0	0	0	0	0
0445	55	2	39	9	0	0	5	0	0	0	0	0	0	0	0
0500	75	1	52	19	0	1	1	0	0	1	0	0	0	0	0
0515	113	3	72	31	1	1	3	0	0	2	0	0	0	0	0
0530	134	0	96	34	0	1	2	0	1	0	0	0	0	0	0
0545	156	4	98	46	0	2	3	0	1	2	0	0	0	0	0
0600	229	2	142	70	1	6	3	0	1	4	0	0	0	0	0
0615	296	3	200	83	2	3	1	2	0	2	0	0	0	0	0
0630	286	0	195	78	0	3	2	1	2	5	0	0	0	0	0
0645	372	1	266	81	1	10	6	0	3	4	0	0	0	0	0
0700	382	2	283	83	1	6	3	0	2	2	0	0	0	0	0
0715	371	3	294	57	0	7	3	0	3	4	0	0	0	0	0
0730	398	6	280	91	0	9	2	3	2	5	0	0	0	0	0
0745	366	0	263	87	0	4	5	0	1	6	0	0	0	0	0
0800	299	1	194	78	0	17	2	0	5	2	0	0	0	0	0
0815	267	1	189	51	1	11	4	0	6	4	0	0	0	0	0
0830	221	1	144	54	1	8	9	0	3	0	1	0	0	0	0
0845	197	1	123	52	0	8	6	1	4	2	0	0	0	0	0
0900	144	1	88	44	0	4	2	0	3	1	0	0	0	1	0
0915	170	0	107	43	0	3	6	0	2	7	0	0	0	2	0
0930	182	1	110	49	0	2	9	3	4	4	0	0	0	0	0
0945	167	0	105	43	0	5	6	1	4	3	0	0	0	0	0
1000	135	2	76	37	0	1	6	2	5	4	2	0	0	0	0
1015	147	0	91	37	1	3	4	1	5	5	0	0	0	0	0



0245	8	0	6	2	0	0	0	0	0	0	0	0	0	0
0300	15	0	12	2	0	0	0	0	0	1	0	0	0	0
0315	16	0	11	3	0	2	0	0	0	0	0	0	0	0
0330	13	0	10	3	0	0	0	0	0	0	0	0	0	0
0345	11	0	7	4	0	0	0	0	0	0	0	0	0	0
0400	17	1	13	3	0	0	0	0	0	0	0	0	0	0
0415	34	1	22	9	0	1	0	0	1	0	0	0	0	0
0430	30	1	18	9	0	0	0	0	0	2	0	0	0	0
0445	44	3	26	10	0	0	3	0	1	1	0	0	0	0
0500	88	2	58	25	0	1	2	0	0	0	0	0	0	0
0515	102	3	65	30	0	1	1	0	0	2	0	0	0	0
0530	152	1	105	38	1	2	0	0	1	3	1	0	0	0
0545	188	3	128	50	0	3	1	0	1	1	1	0	0	0
0600	202	3	129	53	2	3	9	0	0	3	0	0	0	0
0615	297	3	202	83	2	2	3	0	0	1	0	0	0	1
0630	307	1	229	64	0	3	6	0	3	1	0	0	0	0
0645	313	3	233	64	0	6	4	0	2	1	0	0	0	0
0700	355	7	271	66	1	3	6	0	0	1	0	0	0	0
0715	365	5	284	65	0	4	5	0	2	0	0	0	0	0
0730	417	3	325	81	0	1	4	0	1	2	0	0	0	0
0745	380	5	278	78	0	2	12	0	2	3	0	0	0	0
0800	311	2	245	52	0	3	3	0	4	2	0	0	0	0
0815	254	4	178	54	0	6	4	1	4	2	1	0	0	0
0830	214	3	144	53	1	4	3	0	2	3	0	0	0	1
0845	195	2	134	49	0	3	3	1	3	0	0	0	0	0
0900	196	0	121	52	0	12	3	0	6	2	0	0	0	0
0915	158	0	110	34	0	3	4	0	2	5	0	0	0	0
0930	179	3	101	48	0	5	8	0	9	4	1	0	0	0
0945	175	1	107	43	0	11	7	2	2	2	0	0	0	0
1000	149	2	93	33	0	9	1	0	3	8	0	0	0	0
1015	166	2	101	35	0	11	9	0	4	4	0	0	0	0
1030	144	0	74	40	0	8	5	0	8	8	0	0	0	1
1045	154	0	89	48	0	6	2	0	3	4	1	0	0	1
1100	145	4	87	37	0	5	4	0	4	3	1	0	0	0
1115	136	0	79	39	0	4	1	0	8	5	0	0	0	0
1130	145	1	94	38	0	5	2	0	3	2	0	0	0	0
1145	150	1	86	42	1	8	2	3	5	2	0	0	0	0
1200	142	0	86	39	1	7	3	0	2	4	0	0	0	0
1215	161	1	102	32	0	9	5	0	7	5	0	0	0	0
1230	158	5	97	28	2	10	7	0	5	4	0	0	0	0
1245	167	4	89	54	1	8	3	0	2	6	0	0	0	0
1300	184	1	95	58	0	3	5	0	9	12	1	0	0	0
1315	142	2	81	41	1	3	5	0	6	3	0	0	0	0
1330	155	0	93	37	0	7	3	2	5	8	0	0	0	0
1345	155	3	92	36	1	10	3	1	2	6	1	0	0	0
1400	168	3	88	48	0	6	5	0	11	7	0	0	0	0
1415	174	5	101	43	1	8	7	1	4	4	0	0	0	0
1430	191	3	111	56	1	13	3	0	2	2	0	0	0	0
1445	163	3	99	37	0	12	5	0	4	3	0	0	0	0
1500	198	5	117	62	0	2	6	1	5	0	0	0	0	0
1515	158	0	84	56	0	9	1	1	5	2	0	0	0	0
1530	257	2	156	70	1	11	4	2	6	5	0	0	0	0
1545	196	2	113	63	0	5	4	0	6	3	0	0	0	0
1600	185	3	110	51	0	5	5	0	6	4	1	0	0	0
1615	167	2	85	58	2	5	5	0	5	5	0	0	0	0
1630	189	3	110	56	0	7	4	0	4	5	0	0	0	0
1645	183	0	119	47	0	6	4	1	0	6	0	0	0	0
1700	215	2	130	55	0	14	4	0	8	2	0	0	0	0
1715	205	3	127	63	0	3	3	0	4	2	0	0	0	0
1730	195	3	124	53	0	4	4	0	4	3	0	0	0	0
1745	159	2	112	37	0	4	2	1	0	1	0	0	0	0
1800	166	1	111	44	0	4	0	0	4	2	0	0	0	0
1815	142	4	97	32	0	3	1	0	4	1	0	0	0	0
1830	115	3	77	26	0	5	0	0	2	2	0	0	0	0
1845	137	3	88	38	0	5	1	0	1	1	0	0	0	0
1900	108	1	77	24	0	2	2	0	1	1	0	0	0	0
1915	75	1	57	15	0	0	0	0	0	2	0	0	0	0
1930	67	1	46	14	0	2	2	0	0	2	0	0	0	0
1945	57	0	39	16	0	1	0	0	0	1	0	0	0	0
2000	58	1	32	21	0	1	0	0	2	1	0	0	0	0

2015	78	1	56	16	0	3	0	0	2	0	0	0	0	0	0
2030	51	1	39	10	0	0	0	0	0	1	0	0	0	0	0
2045	55	0	40	13	0	2	0	0	0	0	0	0	0	0	0
2100	75	0	47	21	0	2	1	1	0	3	0	0	0	0	0
2115	56	1	45	9	0	0	1	0	0	0	0	0	0	0	0
2130	46	0	36	8	0	0	0	0	2	0	0	0	0	0	0
2145	45	0	33	8	0	4	0	0	0	0	0	0	0	0	0
2200	43	0	35	7	0	1	0	0	0	0	0	0	0	0	0
2215	32	0	26	4	0	1	0	0	0	1	0	0	0	0	0
2230	29	0	21	7	0	1	0	0	0	0	0	0	0	0	0
2245	26	0	18	5	0	0	0	0	1	2	0	0	0	0	0
2300	29	0	24	4	0	1	0	0	0	0	0	0	0	0	0
2315	15	0	4	6	0	1	4	0	0	0	0	0	0	0	0
2330	21	1	17	3	0	0	0	0	0	0	0	0	0	0	0
2345	18	1	12	3	0	1	0	0	1	0	0	0	0	0	0
<b>00-00</b>	<b>12156</b>	<b>147</b>	<b>7954</b>	<b>3000</b>	<b>19</b>	<b>349</b>	<b>232</b>	<b>18</b>	<b>217</b>	<b>207</b>	<b>9</b>	<b>0</b>	<b>0</b>	<b>4</b>	<b>0</b>

**Thursday, January 10, 2013**

Time	Total	Cls													
		1	2	3	4	5	6	7	8	9	10	11	12	13	14
0000	16	0	11	5	0	0	0	0	0	0	0	0	0	0	0
0015	15	1	9	4	0	1	0	0	0	0	0	0	0	0	0
0030	4	0	3	1	0	0	0	0	0	0	0	0	0	0	0
0045	7	0	5	2	0	0	0	0	0	0	0	0	0	0	0
0100	7	1	2	2	0	0	1	0	0	1	0	0	0	0	0
0115	9	0	8	0	0	0	0	0	0	1	0	0	0	0	0
0130	16	0	15	1	0	0	0	0	0	0	0	0	0	0	0
0145	6	0	3	1	0	0	0	0	0	2	0	0	0	0	0
0200	6	0	4	2	0	0	0	0	0	0	0	0	0	0	0
0215	8	0	4	4	0	0	0	0	0	0	0	0	0	0	0
0230	5	0	3	1	0	0	0	0	0	1	0	0	0	0	0
0245	6	0	2	4	0	0	0	0	0	0	0	0	0	0	0
0300	11	1	9	0	0	1	0	0	0	0	0	0	0	0	0
0315	14	0	9	2	0	2	0	0	0	1	0	0	0	0	0
0330	9	1	6	1	0	0	0	0	0	1	0	0	0	0	0
0345	8	0	5	2	0	0	0	0	0	0	1	0	0	0	0
0400	22	1	17	4	0	0	0	0	0	0	0	0	0	0	0
0415	29	1	22	5	0	0	0	0	1	0	0	0	0	0	0
0430	32	1	17	14	0	0	0	0	0	0	0	0	0	0	0
0445	47	2	33	9	0	1	2	0	0	0	0	0	0	0	0
0500	76	5	45	23	0	0	2	0	0	1	0	0	0	0	0
0515	98	3	58	28	0	5	3	0	1	0	0	0	0	0	0
0530	150	1	100	44	0	2	1	0	0	2	0	0	0	0	0
0545	171	2	121	43	1	2	0	0	2	0	0	0	0	0	0
0600	204	2	132	62	1	5	1	0	0	1	0	0	0	0	0
0615	254	2	177	65	1	4	1	0	3	0	0	0	0	1	0
0630	364	3	257	92	0	7	2	0	2	1	0	0	0	0	0
0645	308	2	227	67	0	5	4	0	2	1	0	0	0	0	0
0700	368	2	290	68	2	1	3	0	2	0	0	0	0	0	0
0715	356	3	264	78	0	5	2	0	2	2	0	0	0	0	0
0730	462	6	337	101	1	6	5	0	6	0	0	0	0	0	0
0745	349	5	262	75	0	3	4	0	0	0	0	0	0	0	0
0800	320	3	234	68	0	6	5	0	4	0	0	0	0	0	0
0815	268	1	194	58	0	6	5	0	0	4	0	0	0	0	0
0830	213	1	138	52	0	11	5	0	5	1	0	0	0	0	0
0845	187	2	136	36	0	5	2	0	3	3	0	0	0	0	0
0900	169	1	115	36	0	7	2	1	2	4	0	0	0	1	0
0915	149	2	89	39	1	3	3	0	3	9	0	0	0	0	0
0930	178	4	114	38	0	7	3	0	5	7	0	0	0	0	0
0945	137	0	84	40	0	2	0	0	5	6	0	0	0	0	0
1000	145	1	92	33	0	7	1	2	4	4	1	0	0	0	0
1015	159	2	86	43	0	7	4	0	9	8	0	0	0	0	0
1030	36	0	21	11	0	1	1	0	1	1	0	0	0	0	0
1045	238	6	144	58	0	4	6	0	7	13	0	0	0	0	0
1100	153	2	101	35	0	6	1	0	5	3	0	0	0	0	0
1115	167	5	106	36	0	3	1	0	7	8	1	0	0	0	0
1130	157	1	94	43	0	6	2	1	3	6	1	0	0	0	0
1145	164	4	97	41	0	12	1	0	5	3	1	0	0	0	0
1200	146	1	94	38	0	5	0	0	6	2	0	0	0	0	0
1215	152	4	93	39	0	4	1	0	5	6	0	0	0	0	0

1230	155	5	82	47	0	7	2	0	7	5	0	0	0	0	0
1245	159	0	102	45	0	4	4	0	2	2	0	0	0	0	0
1300	149	4	87	40	0	7	3	0	2	5	1	0	0	0	0
1315	157	4	84	46	0	8	3	0	5	7	0	0	0	0	0
1330	164	1	99	38	1	7	4	0	8	5	1	0	0	0	0
1345	155	2	82	41	1	11	8	0	6	4	0	0	0	0	0
1400	168	6	90	50	0	6	6	1	6	3	0	0	0	0	0
1415	173	2	107	43	0	10	3	0	5	1	2	0	0	0	0
1430	200	2	115	50	1	17	9	0	3	3	0	0	0	0	0
1445	156	4	96	36	0	7	4	0	4	4	1	0	0	0	0
1500	171	3	96	51	0	12	1	2	4	2	0	0	0	0	0
1515	198	5	104	62	0	6	6	1	10	4	0	0	0	0	0
1530	263	2	148	92	0	8	3	0	4	6	0	0	0	0	0
1545	201	3	119	52	0	5	8	0	8	5	1	0	0	0	0
1600	180	2	104	53	0	8	3	0	4	5	1	0	0	0	0
1615	174	2	104	44	1	13	3	0	1	6	0	0	0	0	0
1630	187	3	110	52	0	9	1	1	5	6	0	0	0	0	0
1645	181	4	108	50	0	4	3	0	4	7	1	0	0	0	0
1700	190	2	113	64	0	7	1	0	2	1	0	0	0	0	0
1715	195	4	131	50	0	4	0	0	3	3	0	0	0	0	0
1730	185	1	115	56	0	8	1	0	3	1	0	0	0	0	0
1745	153	2	97	40	0	8	1	0	3	2	0	0	0	0	0
1800	179	3	109	57	0	5	1	0	3	1	0	0	0	0	0
1815	138	3	95	32	0	1	0	0	4	3	0	0	0	0	0
1830	128	4	86	30	0	2	0	0	6	0	0	0	0	0	0
1845	125	1	89	27	0	3	1	0	2	2	0	0	0	0	0
1900	87	1	61	22	0	1	0	0	2	0	0	0	0	0	0
1915	95	1	72	15	0	4	2	0	0	1	0	0	0	0	0
1930	66	0	47	16	0	1	1	0	0	0	1	0	0	0	0
1945	79	2	54	19	0	0	1	0	1	2	0	0	0	0	0
2000	60	3	40	14	0	1	1	0	0	1	0	0	0	0	0
2015	89	1	61	19	0	0	0	0	2	4	2	0	0	0	0
2030	71	3	48	18	0	2	0	0	0	0	0	0	0	0	0
2045	76	3	51	17	0	2	2	0	0	1	0	0	0	0	0
2100	48	1	26	15	0	2	1	0	1	2	0	0	0	0	0
2115	59	1	38	19	0	0	1	0	0	0	0	0	0	0	0
2130	46	1	34	8	0	1	2	0	0	0	0	0	0	0	0
2145	46	0	39	4	0	2	1	0	0	0	0	0	0	0	0
2200	37	1	25	7	0	2	2	0	0	0	0	0	0	0	0
2215	36	1	28	4	0	1	0	0	0	2	0	0	0	0	0
2230	33	1	26	5	0	0	0	0	0	1	0	0	0	0	0
2245	29	1	20	5	0	2	0	0	0	0	1	0	0	0	0
2300	21	0	14	7	0	0	0	0	0	0	0	0	0	0	0
2315	20	0	14	5	0	0	1	0	0	0	0	0	0	0	0
2330	30	2	19	9	0	0	0	0	0	0	0	0	0	0	0
2345	12	0	9	2	0	0	0	0	1	0	0	0	0	0	0
<b>00-00</b>	<b>12099</b>	<b>182</b>	<b>7887</b>	<b>3032</b>	<b>11</b>	<b>360</b>	<b>168</b>	<b>9</b>	<b>221</b>	<b>210</b>	<b>17</b>	<b>0</b>	<b>0</b>	<b>2</b>	<b>0</b>

**Grand Total**

<b>Time</b>	<b>Total</b>	<b>Cls</b>	<b>Cls</b>	<b>Cls</b>	<b>Cls</b>	<b>Cls</b>	<b>Cls</b>	<b>Cls</b>	<b>Cls</b>	<b>Cls</b>	<b>Cls</b>	<b>Cls</b>	<b>Cls</b>	<b>Cls</b>	<b>Cls</b>
--		<b>1</b>	<b>2</b>	<b>3</b>	<b>4</b>	<b>5</b>	<b>6</b>	<b>7</b>	<b>8</b>	<b>9</b>	<b>10</b>	<b>11</b>	<b>12</b>	<b>13</b>	<b>14</b>
--	36286	430	23555	9152	48	1073	652	59	665	607	32	0	0	13	0

## Southern Traffic Services, Inc. Class Speed Matrix

**US 41 between Kracker Avenue & Gibsonton Drive**

**Southbound**

**27.82820 , -82.38197**

**Datasets:**

**Site:** [13] !CC  
**Site:** [13] !C6543  
**Direction:** 3 - South bound, A hit first., Lane: 1  
**Survey Duration:** 7:57 Monday, January 07, 2013 => 10:56 Friday, January 11, 2013  
**File:** G:\DATA\2013\Private\13015\marco\Jan -11-2013 DATA\UM13 SB Slow.eco (Plus)  
**Identifier:** T583MW10 MC56-L5 [MC55] (c)Microcom 19Oct04  
**Algorithm:** Factory default  
**Data type:** Axle sensors - Paired (Class, Speed, Count)

**Profile:**

**Filter time:** 0:00 Tuesday, January 08, 2013 => 0:00 Friday, January 11, 2013  
**Included classes:** 1, 2, 3, 4, 5, 6, 7, 8, 9, 10, 11, 12, 13, 14  
**Speed range:** 0 - 100 mph.  
**Direction:** South (bound)

**Speed (mph)**

	Class														<u>Speed Totals</u>	
	1	2	3	4	5	6	7	8	9	10	11	12	13	14		
0 - 5	.	.	.	.	.	.	.	.	.	.	.	.	.	.	0	0.0%
5 - 10	1	3	.	.	.	.	.	.	.	.	.	.	.	.	4	0.0%
10 - 15	3	12	5	.	1	.	.	.	.	.	.	.	.	.	21	0.1%
15 - 20	4	10	5	.	1	2	1	.	.	.	.	.	.	.	23	0.1%
20 - 25	3	38	20	.	7	2	.	3	2	.	.	.	.	.	75	0.2%
25 - 30	2	48	35	1	7	4	1	4	.	.	.	.	.	.	102	0.3%
30 - 35	1	100	73	.	11	9	2	6	2	.	.	.	.	.	204	0.6%
35 - 40	10	335	175	10	51	19	13	19	5	.	.	.	1	.	638	1.7%
40 - 45	7	1031	544	6	86	55	10	48	33	3	.	.	.	.	1823	5.0%
45 - 50	37	3108	1420	13	207	113	39	113	89	16	.	.	4	.	5159	14.0%
50 - 55	89	6804	2883	15	337	162	37	208	168	16	.	.	.	.	10719	29.2%
55 - 60	129	7480	3082	11	328	125	10	156	151	7	.	.	2	.	11481	31.3%
60 - 65	94	3358	1387	4	117	33	.	42	47	3	.	.	1	.	5086	13.8%
65 - 70	32	752	307	1	27	18	.	5	11	.	.	.	.	.	1153	3.1%
70 - 75	8	128	40	.	3	1	.	.	.	.	.	.	.	.	180	0.5%
75 - 80	5	28	10	.	1	.	.	.	.	.	.	.	.	.	44	0.1%
80 - 85	3	4	3	.	.	.	.	.	.	.	.	.	.	.	10	0.0%
85 - 90	3	.	.	.	.	.	.	.	.	.	.	.	.	.	3	0.0%
90 - 95	3	.	.	.	.	.	.	.	.	.	.	.	.	.	3	0.0%
95 - 100	1	.	1	.	.	.	.	.	.	.	.	.	.	.	2	0.0%
	<b>435</b>	<b>23239</b>	<b>9990</b>	<b>61</b>	<b>1184</b>	<b>543</b>	<b>113</b>	<b>604</b>	<b>508</b>	<b>45</b>	<b>0</b>	<b>0</b>	<b>8</b>	<b>0</b>	<b>36730</b>	
	<b>1.2%</b>	<b>63.3%</b>	<b>27.2%</b>	<b>0.2%</b>	<b>3.2%</b>	<b>1.5%</b>	<b>0.3%</b>	<b>1.6%</b>	<b>1.4%</b>	<b>0.1%</b>	<b>0.0%</b>	<b>0.0%</b>	<b>0.0%</b>	<b>0.0%</b>		
	<b>Class Totals</b>															

# Southern Traffic Services, Inc.

## Vehicle Counts

**US 41 between Kracker Avenue & Gibsonton Drive**

**Southbound**

**27.82820 , -82.38197**

**Datasets:**

**Site:** [13] !CC  
**Site:** [13] !C6543  
**Direction:** 3 - South bound, A hit first., Lane: 1  
**Survey Duration:** 7:57 Monday, January 07, 2013 => 10:56 Friday, January 11, 2013  
**File:** G:\DATA\2013\Private\13015\marco\Jan -11-2013 DATA\UM13 SB Slow.eco (Plus)  
**Identifier:** T583MW10 MC56-L5 [MC55] (c)Microcom 19Oct04  
**Algorithm:** Factory default  
**Data type:** Axle sensors - Paired (Class, Speed, Count)

**Profile:**

**Filter time:** 0:00 Tuesday, January 08, 2013 => 1:00 Friday, January 11, 2013  
**Included classes:** 1, 2, 3, 4, 5, 6, 7, 8, 9, 10, 11, 12, 13, 14  
**Speed range:** 0 - 100 mph.  
**Direction:** South (bound)  
**Separation:** All - (Headway)  
**Name:** Factory default profile  
**Scheme:** Vehicle classification (FLDOT)  
**Units:** Non metric (ft, mi, ft/s, mph, lb, ton)  
**In profile:** Vehicles = 36730

**Tuesday, January 08, 2013 - Total=12180, 15 minute drops**

0000	0100	0200	0300	0400	0500	0600	0700	0800	0900	1000	1100	1200	1300	1400	1500	1600	1700	1800	1900	2000	2100	2200	2300	
127	52	39	48	82	196	529	642	523	524	482	573	560	609	650	986	1266	1461	1100	574	452	311	251	143	
39	13	7	11	8	20	98	156	128	121	112	133	154	136	164	157	306	345	337	163	126	77	84	33	22
62	13	7	9	24	38	145	158	136	136	130	141	150	109	179	240	289	381	331	132	131	79	72	38	31
18	14	16	16	24	64	136	174	147	134	112	158	113	217	163	289	337	374	228	136	105	70	57	43	15
8	12	9	12	26	74	150	154	112	133	128	141	143	147	144	300	334	361	204	143	90	85	38	29	8

AM Peak 0700 - 0800 (642), AM PHF=0.92 PM Peak 1700 - 1800 (1461), PM PHF=0.96

**Wednesday, January 09, 2013 - Total=12300, 15 minute drops**

0000	0100	0200	0300	0400	0500	0600	0700	0800	0900	1000	1100	1200	1300	1400	1500	1600	1700	1800	1900	2000	2100	2200	2300	
76	54	50	37	66	226	533	662	558	509	535	514	623	606	709	976	1247	1459	1040	583	436	375	264	162	
22	13	13	6	10	18	110	154	130	127	141	125	157	159	157	189	307	332	338	163	118	102	84	49	26
31	16	14	14	18	36	124	149	148	136	133	136	140	133	186	230	290	422	277	107	117	96	62	33	25
15	17	15	9	15	70	165	188	139	107	132	141	173	155	179	271	336	354	226	190	104	101	65	49	21
8	8	8	8	23	102	134	171	141	139	129	112	153	159	187	286	314	351	199	123	97	76	53	31	23

AM Peak 0700 - 0800 (662), AM PHF=0.88 PM Peak 1715 - 1815 (1465), PM PHF=0.87

**Thursday, January 10, 2013 - Total=12250, 15 minute drops**

0000	0100	0200	0300	0400	0500	0600	0700	0800	0900	1000	1100	1200	1300	1400	1500	1600	1700	1800	1900	2000	2100	2200	2300	
95	68	46	36	75	208	537	688	463	525	465	539	582	594	745	960	1230	1482	1031	632	500	316	263	170	
26	15	9	8	12	26	109	152	101	140	101	131	144	146	151	218	294	342	288	202	155	91	63	13	32
25	13	14	9	17	39	151	173	148	118	111	128	151	151	198	223	309	397	275	168	112	94	73	76	38
21	22	14	10	19	55	148	190	130	139	119	141	143	101	182	234	279	385	251	148	109	64	65	38	26
23	18	9	9	27	88	129	173	84	128	134	139	144	196	214	285	348	358	217	114	124	67	62	43	19

AM Peak 0700 - 0800 (688), AM PHF=0.91 PM Peak 1700 - 1800 (1482), PM PHF=0.93



# Southern Traffic Services, Inc.

## Classification Count

**US 41 between Kracker Avenue & Gibsonton Drive**

**Southbound**

**27.82820 , -82.38197**

**Datasets:**

**Site:** [13] ICC  
**Site:** [13] IC6543  
**Direction:** 3 - South bound, A hit first., Lane: 1  
**Survey Duration:** 7:57 Monday, January 07, 2013 => 10:56 Friday, January 11, 2013  
**File:** G:\DATA\2013\Private\13015\marco\Jan -11-2013 DATA\UM13 SB Slow.eco (Plus)  
**Identifier:** T583MW10 MC56-L5 [MC55] (c)Microcom 19Oct04  
**Algorithm:** Factory default  
**Data type:** Axle sensors - Paired (Class, Speed, Count)

**Profile:**

**Filter time:** 0:00 Tuesday, January 08, 2013 => 0:00 Friday, January 11, 2013  
**Included classes:** 1, 2, 3, 4, 5, 6, 7, 8, 9, 10, 11, 12, 13, 14  
**Speed range:** 0 - 100 mph.  
**Direction:** South (bound)

**Tuesday, January 08, 2013**

Time	Total	Cls 1	Cls 2	Cls 3	Cls 4	Cls 5	Cls 6	Cls 7	Cls 8	Cls 9	Cls 10	Cls 11	Cls 12	Cls 13	Cls 14
0000	39	1	35	3	0	0	0	0	0	0	0	0	0	0	0
0015	63	0	49	14	0	0	0	0	0	0	0	0	0	0	0
0030	17	0	12	5	0	0	0	0	0	0	0	0	0	0	0
0045	8	0	6	2	0	0	0	0	0	0	0	0	0	0	0
0100	13	0	8	4	0	1	0	0	0	0	0	0	0	0	0
0115	13	1	8	4	0	0	0	0	0	0	0	0	0	0	0
0130	14	0	11	3	0	0	0	0	0	0	0	0	0	0	0
0145	12	0	9	2	1	0	0	0	0	0	0	0	0	0	0
0200	7	0	4	2	0	1	0	0	0	0	0	0	0	0	0
0215	7	0	4	3	0	0	0	0	0	0	0	0	0	0	0
0230	16	0	9	6	0	0	0	0	1	0	0	0	0	0	0
0245	9	0	6	2	0	0	0	0	1	0	0	0	0	0	0
0300	11	1	4	4	0	1	0	0	0	1	0	0	0	0	0
0315	9	0	4	2	0	0	2	0	0	1	0	0	0	0	0
0330	16	0	8	5	0	0	1	0	0	2	0	0	0	0	0
0345	12	0	7	3	0	0	0	0	0	2	0	0	0	0	0
0400	8	0	1	3	0	0	0	0	1	3	0	0	0	0	0
0415	24	0	12	5	0	1	3	0	2	1	0	0	0	0	0
0430	24	0	16	4	0	0	2	0	0	2	0	0	0	0	0
0445	26	0	11	7	0	1	5	0	0	2	0	0	0	0	0
0500	20	0	16	1	0	0	1	0	0	2	0	0	0	0	0
0515	38	0	17	13	1	1	3	0	1	2	0	0	0	0	0
0530	64	1	30	20	0	4	6	0	0	3	0	0	0	0	0
0545	74	1	32	34	0	2	3	0	0	2	0	0	0	0	0
0600	98	2	52	35	0	1	4	0	1	3	0	0	0	0	0
0615	145	1	65	60	0	6	5	0	5	2	1	0	0	0	0
0630	137	2	64	49	1	10	6	0	2	3	0	0	0	0	0
0645	149	1	73	53	1	12	3	1	1	3	1	0	0	0	0
0700	156	1	92	40	1	4	7	1	7	3	0	0	0	0	0
0715	158	1	101	37	0	7	5	1	3	3	0	0	0	0	0
0730	174	1	96	55	1	8	3	0	5	5	0	0	0	0	0
0745	154	0	82	50	1	9	4	0	3	3	1	0	0	1	0
0800	128	0	70	37	0	8	3	1	6	2	1	0	0	0	0
0815	137	0	69	42	0	7	3	3	7	6	0	0	0	0	0
0830	146	1	77	45	2	7	7	0	1	6	0	0	0	0	0
0845	112	0	54	45	0	4	3	0	2	3	1	0	0	0	0
0900	121	3	60	35	1	7	4	0	7	4	0	0	0	0	0
0915	136	0	68	43	2	6	5	3	6	2	1	0	0	0	0
0930	134	0	76	42	0	7	3	2	3	1	0	0	0	0	0
0945	133	0	78	35	0	4	6	3	3	4	0	0	0	0	0
1000	112	0	60	35	0	7	3	1	3	2	1	0	0	0	0
1015	130	1	71	41	0	9	2	2	3	1	0	0	0	0	0

1030	112	2	57	31	0	4	6	3	6	3	0	0	0	0	0
1045	128	0	66	43	0	4	4	0	7	4	0	0	0	0	0
1100	133	1	73	39	0	7	1	2	3	7	0	0	0	0	0
1115	141	1	74	43	0	2	6	5	3	7	0	0	0	0	0
1130	158	0	85	50	0	9	2	5	2	4	1	0	0	0	0
1145	141	3	86	32	0	6	6	1	3	4	0	0	0	0	0
1200	154	2	68	61	0	5	7	3	2	5	1	0	0	0	0
1215	150	0	75	53	0	9	3	1	4	4	1	0	0	0	0
1230	113	2	65	36	0	6	1	0	2	1	0	0	0	0	0
1245	143	4	74	41	0	2	7	4	3	8	0	0	0	0	0
1300	136	4	71	44	0	5	4	2	4	2	0	0	0	0	0
1315	109	0	65	31	0	5	0	1	6	1	0	0	0	0	0
1330	218	2	132	57	0	13	3	3	5	3	0	0	0	0	0
1345	146	0	86	42	0	8	4	1	3	2	0	0	0	0	0
1400	164	2	93	53	0	4	2	4	5	1	0	0	0	0	0
1415	179	1	113	43	1	14	3	1	0	3	0	0	0	0	0
1430	163	0	89	61	1	5	1	2	0	4	0	0	0	0	0
1445	144	1	85	43	0	6	2	3	2	2	0	0	0	0	0
1500	157	2	95	45	0	8	1	1	4	1	0	0	0	0	0
1515	240	4	146	70	0	10	2	1	7	0	0	0	0	0	0
1530	290	6	175	88	0	7	6	0	6	2	0	0	0	0	0
1545	299	3	208	77	0	5	2	1	2	1	0	0	0	0	0
1600	307	3	178	106	1	11	2	1	4	1	0	0	0	0	0
1615	288	3	188	79	0	7	6	0	2	3	0	0	0	0	0
1630	337	2	240	71	0	15	1	0	5	2	1	0	0	0	0
1645	334	4	234	80	0	10	0	1	3	2	0	0	0	0	0
1700	345	3	236	88	0	9	6	0	2	1	0	0	0	0	0
1715	381	5	269	92	2	9	2	0	1	1	0	0	0	0	0
1730	374	3	278	86	1	5	0	0	1	0	0	0	0	0	0
1745	363	5	256	85	0	10	2	0	2	3	0	0	0	0	0
1800	335	1	247	75	0	6	2	0	3	1	0	0	0	0	0
1815	331	2	235	83	0	7	1	0	3	0	0	0	0	0	0
1830	229	4	165	53	0	2	3	0	1	1	0	0	0	0	0
1845	203	0	143	53	0	4	1	0	2	0	0	0	0	0	0
1900	163	6	110	41	0	1	4	0	1	0	0	0	0	0	0
1915	132	1	97	32	0	1	1	0	0	0	0	0	0	0	0
1930	136	0	97	34	0	3	2	0	0	0	0	0	0	0	0
1945	143	0	104	34	0	2	2	0	1	0	0	0	0	0	0
2000	126	2	85	31	0	4	2	0	0	2	0	0	0	0	0
2015	131	1	96	30	0	3	0	0	0	1	0	0	0	0	0
2030	105	0	79	23	0	0	1	0	0	2	0	0	0	0	0
2045	91	0	74	14	0	2	1	0	0	0	0	0	0	0	0
2100	76	1	50	22	0	2	1	0	0	0	0	0	0	0	0
2115	79	3	55	20	0	1	0	0	0	0	0	0	0	0	0
2130	70	1	47	16	0	3	2	0	1	0	0	0	0	0	0
2145	85	1	55	26	0	1	1	0	1	0	0	0	0	0	0
2200	85	0	72	12	0	0	0	0	1	0	0	0	0	0	0
2215	71	0	56	13	0	1	0	0	1	0	0	0	0	0	0
2230	57	3	32	19	0	1	1	0	1	0	0	0	0	0	0
2245	38	2	30	6	0	0	0	0	0	0	0	0	0	0	0
2300	33	0	28	4	0	0	0	0	0	1	0	0	0	0	0
2315	38	0	26	11	0	0	0	0	0	1	0	0	0	0	0
2330	43	0	34	9	0	0	0	0	0	0	0	0	0	0	0
2345	29	0	21	7	0	0	0	0	0	1	0	0	0	0	0
<b>00-00</b>	<b>12180</b>	<b>115</b>	<b>7625</b>	<b>3368</b>	<b>18</b>	<b>399</b>	<b>219</b>	<b>64</b>	<b>188</b>	<b>172</b>	<b>11</b>	<b>0</b>	<b>0</b>	<b>1</b>	<b>0</b>

**Wednesday, January 09, 2013**

Time	Total	Cls 1	Cls 2	Cls 3	Cls 4	Cls 5	Cls 6	Cls 7	Cls 8	Cls 9	Cls 10	Cls 11	Cls 12	Cls 13	Cls 14
0000	22	0	16	4	0	0	1	0	0	1	0	0	0	0	0
0015	31	0	19	11	0	1	0	0	0	0	0	0	0	0	0
0030	15	0	12	2	0	1	0	0	0	0	0	0	0	0	0
0045	8	0	5	2	0	0	0	0	0	1	0	0	0	0	0
0100	13	0	10	3	0	0	0	0	0	0	0	0	0	0	0
0115	16	0	10	4	0	0	0	0	1	1	0	0	0	0	0
0130	17	0	11	3	0	2	0	0	0	1	0	0	0	0	0
0145	8	0	6	2	0	0	0	0	0	0	0	0	0	0	0
0200	13	0	8	4	0	0	0	0	1	0	0	0	0	0	0
0215	14	0	8	4	0	1	0	0	0	1	0	0	0	0	0
0230	15	0	13	1	0	0	0	0	0	1	0	0	0	0	0

0245	8	0	6	2	0	0	0	0	0	0	0	0	0	0	0
0300	6	0	3	3	0	0	0	0	0	0	0	0	0	0	0
0315	14	0	11	2	0	0	0	0	0	1	0	0	0	0	0
0330	9	0	3	5	0	0	0	0	0	1	0	0	0	0	0
0345	8	0	6	2	0	0	0	0	0	0	0	0	0	0	0
0400	10	0	4	5	0	0	0	0	0	1	0	0	0	0	0
0415	18	0	10	6	0	0	0	0	2	0	0	0	0	0	0
0430	15	0	11	4	0	0	0	0	0	0	0	0	0	0	0
0445	23	0	12	6	0	1	0	0	1	3	0	0	0	0	0
0500	18	0	11	6	0	0	0	0	0	1	0	0	0	0	0
0515	36	0	10	17	0	2	1	0	2	4	0	0	0	0	0
0530	70	2	27	24	0	2	8	0	0	7	0	0	0	0	0
0545	102	3	48	34	0	6	7	0	2	1	0	0	0	1	0
0600	110	1	54	37	1	2	8	1	1	4	0	0	0	1	0
0615	125	2	73	39	0	2	2	0	3	4	0	0	0	0	0
0630	164	2	81	60	0	7	7	1	2	4	0	0	0	0	0
0645	134	1	64	42	1	12	10	0	2	2	0	0	0	0	0
0700	154	1	88	39	2	8	2	1	2	11	0	0	0	0	0
0715	149	2	101	32	0	4	5	2	1	1	1	0	0	0	0
0730	188	1	115	52	2	10	2	0	4	2	0	0	0	0	0
0745	171	1	104	43	0	3	3	1	9	7	0	0	0	0	0
0800	131	1	77	36	0	8	1	0	6	1	1	0	0	0	0
0815	148	0	78	47	1	8	3	0	4	6	1	0	0	0	0
0830	139	2	64	47	0	4	5	0	11	3	2	0	0	1	0
0845	140	1	80	42	0	2	6	2	4	2	1	0	0	0	0
0900	127	1	65	46	0	8	0	1	5	1	0	0	0	0	0
0915	136	2	68	47	1	6	1	0	5	5	0	0	0	1	0
0930	107	0	60	32	1	4	3	0	6	1	0	0	0	0	0
0945	139	0	84	35	0	7	1	0	11	1	0	0	0	0	0
1000	141	0	75	39	0	11	1	2	6	6	1	0	0	0	0
1015	133	1	75	40	0	6	2	1	1	6	1	0	0	0	0
1030	133	1	82	37	1	5	3	0	2	2	0	0	0	0	0
1045	128	0	67	37	0	3	7	2	4	8	0	0	0	0	0
1100	125	2	63	41	1	8	1	1	3	4	1	0	0	0	0
1115	136	6	75	38	0	5	4	1	4	3	0	0	0	0	0
1130	141	2	82	40	0	7	1	2	4	3	0	0	0	0	0
1145	112	1	58	39	1	10	1	0	2	0	0	0	0	0	0
1200	157	1	81	56	0	10	2	2	3	2	0	0	0	0	0
1215	140	1	88	36	1	8	1	1	2	2	0	0	0	0	0
1230	174	1	99	57	0	8	1	0	4	4	0	0	0	0	0
1245	152	1	96	41	0	4	2	0	3	5	0	0	0	0	0
1300	159	4	82	51	0	7	4	1	6	4	0	0	0	0	0
1315	133	0	71	40	0	10	2	2	5	3	0	0	0	0	0
1330	155	1	93	42	0	11	1	1	5	0	1	0	0	0	0
1345	159	4	97	42	0	7	3	0	3	3	0	0	0	0	0
1400	157	3	90	45	1	10	2	0	2	4	0	0	0	0	0
1415	187	2	117	52	2	5	2	0	3	4	0	0	0	0	0
1430	178	1	120	45	2	5	1	0	4	0	0	0	0	0	0
1445	187	5	107	55	0	9	4	2	3	2	0	0	0	0	0
1500	189	1	122	49	1	5	1	1	7	2	0	0	0	0	0
1515	230	1	137	68	0	12	4	0	6	2	0	0	0	0	0
1530	272	5	167	76	2	10	3	1	5	3	0	0	0	0	0
1545	285	4	179	88	1	8	1	0	2	2	0	0	0	0	0
1600	307	3	201	82	2	12	2	0	4	1	0	0	0	0	0
1615	290	4	194	67	1	12	5	0	5	2	0	0	0	0	0
1630	337	5	209	105	0	9	4	0	5	0	0	0	0	0	0
1645	314	6	200	90	0	12	1	1	3	1	0	0	0	0	0
1700	332	8	234	75	0	10	1	0	4	0	0	0	0	0	0
1715	421	5	314	88	2	5	2	0	1	3	1	0	0	0	0
1730	354	1	269	78	0	2	2	1	0	1	0	0	0	0	0
1745	351	4	248	88	1	5	1	0	3	1	0	0	0	0	0
1800	338	6	235	86	1	6	3	0	1	0	0	0	0	0	0
1815	278	1	192	78	0	6	0	0	1	0	0	0	0	0	0
1830	225	5	157	56	0	4	2	0	0	1	0	0	0	0	0
1845	199	3	142	47	0	4	2	0	1	0	0	0	0	0	0
1900	163	0	110	47	0	4	1	0	0	1	0	0	0	0	0
1915	108	1	67	35	0	3	1	0	1	0	0	0	0	0	0
1930	190	1	145	38	0	4	0	0	1	1	0	0	0	0	0
1945	124	1	82	34	0	5	1	0	1	0	0	0	0	0	0
2000	117	0	93	22	0	0	1	0	1	0	0	0	0	0	0

2015	116	3	80	29	0	3	0	0	1	0	0	0	0	0	0
2030	104	1	79	23	0	1	0	0	0	0	0	0	0	0	0
2045	97	4	59	31	0	2	0	0	1	0	0	0	0	0	0
2100	102	2	73	27	0	0	0	0	0	0	0	0	0	0	0
2115	96	1	74	18	0	1	1	0	1	0	0	0	0	0	0
2130	101	3	80	17	0	1	0	0	0	0	0	0	0	0	0
2145	76	0	65	9	0	1	0	0	1	0	0	0	0	0	0
2200	84	1	66	16	0	0	0	0	1	0	0	0	0	0	0
2215	62	1	46	15	0	0	0	0	0	0	0	0	0	0	0
2230	65	4	46	15	0	0	0	0	0	0	0	0	0	0	0
2245	53	1	39	9	0	2	2	0	0	0	0	0	0	0	0
2300	49	1	41	6	0	0	1	0	0	0	0	0	0	0	0
2315	33	0	26	6	0	1	0	0	0	0	0	0	0	0	0
2330	50	1	35	10	0	2	0	0	0	2	0	0	0	0	0
2345	30	0	26	4	0	0	0	0	0	0	0	0	0	0	0
<b>00-00</b>	<b>12300</b>	<b>148</b>	<b>7786</b>	<b>3337</b>	<b>29</b>	<b>412</b>	<b>163</b>	<b>31</b>	<b>211</b>	<b>168</b>	<b>11</b>	<b>0</b>	<b>0</b>	<b>4</b>	<b>0</b>

**Thursday, January 10, 2013**

Time	Total	Cls													
		1	2	3	4	5	6	7	8	9	10	11	12	13	14
0000	26	1	14	9	0	0	1	0	1	0	0	0	0	0	0
0015	25	1	15	9	0	0	0	0	0	0	0	0	0	0	0
0030	21	0	13	6	0	1	0	0	0	1	0	0	0	0	0
0045	23	1	14	6	0	0	1	0	0	1	0	0	0	0	0
0100	15	2	10	2	0	1	0	0	0	0	0	0	0	0	0
0115	13	0	12	1	0	0	0	0	0	0	0	0	0	0	0
0130	22	0	17	2	0	1	0	0	0	2	0	0	0	0	0
0145	18	1	9	7	0	1	0	0	0	0	0	0	0	0	0
0200	9	0	7	2	0	0	0	0	0	0	0	0	0	0	0
0215	14	1	9	3	0	1	0	0	0	0	0	0	0	0	0
0230	14	0	10	1	0	0	0	0	0	3	0	0	0	0	0
0245	9	0	8	0	0	1	0	0	0	0	0	0	0	0	0
0300	8	0	5	3	0	0	0	0	0	0	0	0	0	0	0
0315	9	0	9	0	0	0	0	0	0	0	0	0	0	0	0
0330	10	0	4	3	0	0	1	0	1	0	1	0	0	0	0
0345	9	0	4	3	0	0	1	0	0	1	0	0	0	0	0
0400	12	1	8	2	0	1	0	0	0	0	0	0	0	0	0
0415	17	0	9	7	0	0	0	0	0	1	0	0	0	0	0
0430	20	0	12	3	0	1	2	0	0	2	0	0	0	0	0
0445	26	0	13	9	0	1	0	0	1	2	0	0	0	0	0
0500	26	1	10	9	0	1	2	0	0	3	0	0	0	0	0
0515	39	0	23	11	0	2	1	0	0	1	1	0	0	0	0
0530	55	0	27	19	0	3	2	0	0	4	0	0	0	0	0
0545	88	3	44	32	0	2	3	0	0	4	0	0	0	0	0
0600	110	6	50	40	1	2	5	0	3	3	0	0	0	0	0
0615	150	1	73	59	0	4	4	0	2	7	0	0	0	0	0
0630	148	3	73	55	0	8	3	1	3	2	0	0	0	0	0
0645	130	2	69	38	1	11	3	0	4	1	1	0	0	0	0
0700	151	2	93	35	1	10	4	0	1	5	0	0	0	0	0
0715	173	0	104	47	0	8	3	0	6	5	0	0	0	0	0
0730	190	1	115	54	1	8	3	0	3	5	0	0	0	0	0
0745	174	0	99	57	0	5	2	0	7	4	0	0	0	0	0
0800	100	1	51	40	0	5	0	1	1	0	1	0	0	0	0
0815	148	2	73	51	0	8	5	0	5	3	1	0	0	0	0
0830	131	0	71	38	0	7	3	1	3	6	1	0	0	1	0
0845	84	0	55	21	0	3	1	0	1	2	1	0	0	0	0
0900	139	1	77	38	0	7	5	0	4	5	2	0	0	0	0
0915	118	1	70	27	0	7	3	0	6	4	0	0	0	0	0
0930	139	2	70	48	0	8	5	1	5	0	0	0	0	0	0
0945	128	1	66	46	1	5	4	0	5	0	0	0	0	0	0
1000	101	1	55	30	1	3	1	0	7	2	1	0	0	0	0
1015	111	0	63	33	0	6	0	0	5	2	2	0	0	0	0
1030	119	0	60	38	0	8	2	1	7	3	0	0	0	0	0
1045	134	2	69	39	0	6	4	0	9	4	1	0	0	0	0
1100	131	0	76	41	0	3	1	0	3	7	0	0	0	0	0
1115	128	1	82	29	0	5	1	1	4	5	0	0	0	0	0
1130	141	2	79	45	0	5	3	1	2	3	1	0	0	0	0
1145	139	1	78	43	0	3	3	0	3	6	2	0	0	0	0
1200	144	0	70	53	0	7	1	0	7	3	3	0	0	0	0
1215	152	3	85	45	0	6	1	0	6	6	0	0	0	0	0

1230	142	3	87	37	0	4	5	0	4	2	0	0	0	0	0
1245	145	0	92	40	0	4	3	0	2	4	0	0	0	0	0
1300	145	3	85	40	0	8	2	0	2	3	2	0	0	0	0
1315	151	2	84	45	0	5	5	0	4	6	0	0	0	0	0
1330	101	2	62	26	0	3	5	0	2	1	0	0	0	0	0
1345	196	2	118	57	1	6	2	0	7	3	0	0	0	0	0
1400	152	0	91	47	0	2	1	0	5	6	0	0	0	0	0
1415	197	4	127	46	0	7	7	0	4	1	0	0	0	1	0
1430	182	3	107	55	1	12	3	0	0	1	0	0	0	0	0
1445	216	3	125	64	1	5	3	1	10	3	1	0	0	0	0
1500	216	2	131	68	0	10	2	0	1	2	0	0	0	0	0
1515	223	0	140	66	1	5	4	1	4	2	0	0	0	0	0
1530	234	10	137	68	0	6	4	1	6	2	0	0	0	0	0
1545	285	4	191	67	2	13	0	0	6	0	1	0	0	1	0
1600	294	3	193	87	0	4	2	0	2	3	0	0	0	0	0
1615	311	6	227	59	0	10	2	0	4	3	0	0	0	0	0
1630	279	7	177	78	0	9	5	0	2	1	0	0	0	0	0
1645	346	7	245	81	0	7	2	0	3	1	0	0	0	0	0
1700	342	6	231	91	0	10	2	0	1	1	0	0	0	0	0
1715	397	7	285	93	1	6	3	0	2	0	0	0	0	0	0
1730	386	8	284	81	1	7	1	0	4	0	0	0	0	0	0
1745	357	2	254	88	0	8	2	0	3	0	0	0	0	0	0
1800	288	4	210	67	0	7	0	0	0	0	0	0	0	0	0
1815	275	2	211	51	0	6	2	0	1	2	0	0	0	0	0
1830	251	5	183	54	0	5	0	0	3	1	0	0	0	0	0
1845	217	0	152	56	0	6	0	0	1	2	0	0	0	0	0
1900	202	1	133	60	0	5	0	0	3	0	0	0	0	0	0
1915	168	3	122	36	0	3	4	0	0	0	0	0	0	0	0
1930	148	2	102	40	0	3	1	0	0	0	0	0	0	0	0
1945	114	2	86	25	0	1	0	0	0	0	0	0	0	0	0
2000	155	2	111	41	0	1	0	0	0	0	0	0	0	0	0
2015	112	1	82	26	0	2	0	0	1	0	0	0	0	0	0
2030	109	1	74	30	0	1	0	2	1	0	0	0	0	0	0
2045	125	0	88	31	0	4	2	0	0	0	0	0	0	0	0
2100	90	5	66	17	0	1	0	1	0	0	0	0	0	0	0
2115	94	1	70	22	0	0	1	0	0	0	0	0	0	0	0
2130	64	3	46	14	0	0	0	1	0	0	0	0	0	0	0
2145	67	0	57	6	0	0	1	2	1	0	0	0	0	0	0
2200	63	1	50	11	0	1	0	0	0	0	0	0	0	0	0
2215	73	5	56	10	0	1	0	1	0	0	0	0	0	0	0
2230	65	3	39	23	0	0	0	0	0	0	0	0	0	0	0
2245	62	0	50	10	0	0	1	1	0	0	0	0	0	0	0
2300	13	1	11	1	0	0	0	0	0	0	0	0	0	0	0
2315	76	0	63	12	0	0	0	0	1	0	0	0	0	0	0
2330	39	0	32	7	0	0	0	0	0	0	0	0	0	0	0
2345	42	1	29	12	0	0	0	0	0	0	0	0	0	0	0
<b>00-00</b>	<b>12250</b>	<b>172</b>	<b>7828</b>	<b>3285</b>	<b>14</b>	<b>373</b>	<b>161</b>	<b>18</b>	<b>205</b>	<b>168</b>	<b>23</b>	<b>0</b>	<b>0</b>	<b>3</b>	<b>0</b>

**Grand Total**

<b>Time</b>	<b>Total</b>	<b>Cls</b>	<b>Cls</b>	<b>Cls</b>	<b>Cls</b>	<b>Cls</b>	<b>Cls</b>	<b>Cls</b>	<b>Cls</b>	<b>Cls</b>	<b>Cls</b>	<b>Cls</b>	<b>Cls</b>	<b>Cls</b>	<b>Cls</b>
--		<b>1</b>	<b>2</b>	<b>3</b>	<b>4</b>	<b>5</b>	<b>6</b>	<b>7</b>	<b>8</b>	<b>9</b>	<b>10</b>	<b>11</b>	<b>12</b>	<b>13</b>	<b>14</b>
--	36730	435	23239	9990	61	1184	543	113	604	508	45	0	0	8	0

## Traffic Count Data

Finance Number:  
 Location Code:                   1  
 Count Location       US 41 Between Gibsonton Drive and Madison Avenue

TYPE OF COUNT:       72 Hour Class Classification Count

TIME OF COUNT:

Start Date:	1/8/2013	Start Time:	Midnight
End Date:	1/10/2013	End Time:	Midnight

VOLUMES:

	Average Daily:	23,942	Peak Hour Start Time:	5:00 PM
	Daily Truck Average:	2,266	Average Peak Hour:	2,359
			Max Hour Truck Average:	192
			Peak Hour Truck Average:	107

TRAVEL CHARACTERISTICS:

K MEASURED

D MEASURED

	K=	10%		D=	77%
	T Max Hour	18%		T Daily	9%
	T med (max)	6%		T med Daily	4%
	T heavy (max)	13%		T heavy Daily	6%
	T peak Hour	5%			
	T med Peak Hour	2%		Axle Factor	0.94
	T heavy Peak Hour	2%			

## Southern Traffic Services, Inc. Class Speed Matrix

**US 41 between Gibsonton Drive & CR 676A (Madison Avenue)      Northbound      27.87745 , -82.39227**

**Datasets:**

**Site:** [14] !6529  
**Site:** [14] !4206  
**Direction:** 1 - North bound, A hit first., **Lane:** 1  
**Survey Duration:** 6:50 Monday, January 07, 2013 => 12:23 Friday, January 11, 2013  
**File:** G:\DATA\2013\Private\13015\diego\Data 1-7-13\UM14 NB Slow.eco (Plus)  
**Identifier:** P321CE0K MC56-L4 [MC55] (c)Microcom 19Sep03  
**Algorithm:** Factory default  
**Data type:** Axle sensors - Paired (Class, Speed, Count)

**Profile:**

**Filter time:** 0:00 Tuesday, January 08, 2013 => 0:00 Friday, January 11, 2013  
**Included classes:** 1, 2, 3, 4, 5, 6, 7, 8, 9, 10, 11, 12, 13, 14  
**Speed range:** 0 - 100 mph.  
**Direction:** North (bound)

<u>Speed (mph)</u>	<u>Class</u>														<u>Speed Totals</u>	
	1	2	3	4	5	6	7	8	9	10	11	12	13	14		
0 - 5	.	.	.	.	.	.	.	.	.	.	.	.	.	.	0	0.0%
5 - 10	.	.	.	.	.	.	.	.	.	.	.	.	.	.	0	0.0%
10 - 15	2	.	.	.	.	.	.	.	.	.	.	.	.	.	2	0.0%
15 - 20	.	2	.	.	.	1	.	.	.	.	.	.	.	.	3	0.0%
20 - 25	.	4	1	.	.	1	.	1	6	.	.	.	.	.	13	0.0%
25 - 30	1	5	2	.	2	4	1	1	10	.	.	.	.	.	26	0.1%
30 - 35	.	25	13	1	19	7	3	3	21	.	.	.	.	.	92	0.3%
35 - 40	.	117	59	6	22	16	3	14	39	1	.	.	.	.	277	0.8%
40 - 45	6	334	147	1	26	37	3	21	22	.	.	.	2	.	599	1.7%
45 - 50	4	643	281	1	54	52	9	61	45	3	.	.	3	.	1156	3.4%
50 - 55	34	2031	905	4	129	84	17	118	113	7	.	.	3	.	3445	10.0%
55 - 60	81	4936	2278	2	281	140	20	195	244	28	.	.	7	.	8212	23.8%
60 - 65	99	6687	2901	11	324	118	7	122	174	21	.	.	4	.	10468	30.4%
65 - 70	87	4470	1915	2	168	39	.	55	54	6	.	.	2	.	6798	19.7%
70 - 75	45	1531	770	.	71	11	.	14	7	2	.	.	.	.	2451	7.1%
75 - 80	21	385	239	1	24	.	1	1	1	1	.	.	.	.	674	2.0%
80 - 85	15	79	55	.	6	2	.	2	.	.	.	.	.	.	159	0.5%
85 - 90	5	21	13	.	.	.	.	1	.	.	.	.	.	.	40	0.1%
90 - 95	2	8	2	.	.	.	.	.	.	.	.	.	.	.	12	0.0%
95 - 100	1	4	3	.	.	.	.	.	.	.	.	.	.	.	8	0.0%
	<b>403</b>	<b>21282</b>	<b>9584</b>	<b>29</b>	<b>1126</b>	<b>512</b>	<b>64</b>	<b>609</b>	<b>736</b>	<b>69</b>	<b>0</b>	<b>0</b>	<b>21</b>	<b>0</b>	<b>34435</b>	
	<b>1.2%</b>	<b>61.8%</b>	<b>27.8%</b>	<b>0.1%</b>	<b>3.3%</b>	<b>1.5%</b>	<b>0.2%</b>	<b>1.8%</b>	<b>2.1%</b>	<b>0.2%</b>	<b>0.0%</b>	<b>0.0%</b>	<b>0.1%</b>	<b>0.0%</b>		
	<b>Class Totals</b>															

# Southern Traffic Services, Inc.

## Vehicle Counts

**US 41 between Gibsonton Drive & CR 676A (Madison Avenue) Northbound 27.87745 , -82.39227**

**Datasets:**

**Site:** [14] !6529  
**Site:** [14] !4206  
**Direction:** 1 - North bound, A hit first., Lane: 1  
**Survey Duration:** 6:50 Monday, January 07, 2013 => 12:23 Friday, January 11, 2013  
**File:** G:\DATA\2013\Private\13015\diego\Data 1-7-13\UM14 NB Slow.eco (Plus)  
**Identifier:** P321CE0K MC56-L4 [MC55] (c)Microcom 19Sep03  
**Algorithm:** Factory default  
**Data type:** Axle sensors - Paired (Class, Speed, Count)

**Profile:**

**Filter time:** 0:00 Tuesday, January 08, 2013 => 0:00 Friday, January 11, 2013  
**Included classes:** 1, 2, 3, 4, 5, 6, 7, 8, 9, 10, 11, 12, 13, 14  
**Speed range:** 0 - 100 mph.  
**Direction:** North (bound)  
**Separation:** All - (Headway)  
**Name:** Factory default profile  
**Scheme:** Vehicle classification (FLDOT)  
**Units:** Non metric (ft, mi, ft/s, mph, lb, ton)  
**In profile:** Vehicles = 34435

**Tuesday, January 08, 2013 - Total=11488, 15 minute drops**

0000	0100	0200	0300	0400	0500	0600	0700	0800	0900	1000	1100	1200	1300	1400	1500	1600	1700	1800	1900	2000	2100	2200	2300	
41	34	28	81	165	603	1402	1792	1161	675	589	530	553	553	514	588	523	577	389	213	156	154	98	69	
10	10	11	14	21	106	247	415	357	133	151	127	125	156	107	165	124	128	130	66	40	42	25	19	15
10	11	4	22	37	136	259	471	304	208	155	148	133	32	146	130	143	146	101	53	34	44	32	20	11
11	8	7	25	50	173	435	482	279	182	148	126	152	219	136	165	137	154	82	66	51	34	14	20	13
10	5	6	20	57	188	461	424	221	152	135	129	143	146	125	128	119	149	76	28	31	34	27	10	8

AM Peak 0645 - 0745 (1829), AM PHF=0.95 PM Peak 1330 - 1430 (618), PM PHF=0.71

**Wednesday, January 09, 2013 - Total=11536, 15 minute drops**

0000	0100	0200	0300	0400	0500	0600	0700	0800	0900	1000	1100	1200	1300	1400	1500	1600	1700	1800	1900	2000	2100	2200	2300	
47	36	40	83	187	644	1394	1815	1136	674	547	416	585	507	557	585	544	536	436	242	158	176	124	67	
15	7	8	7	26	114	266	425	335	191	154	127	199	133	158	146	140	148	106	71	39	50	38	23	8
11	11	8	21	40	125	367	456	305	164	136	120	70	138	143	141	125	119	120	83	38	55	34	15	16
13	8	11	29	58	186	389	486	256	152	116	145	184	115	132	150	143	137	108	53	46	40	26	13	6
8	10	13	26	63	219	372	448	240	167	141	24	132	121	124	148	136	132	102	35	35	31	26	16	9

AM Peak 0700 - 0800 (1815), AM PHF=0.93 PM Peak 1230 - 1330 (587), PM PHF=0.80

**Thursday, January 10, 2013 - Total=11411, 15 minute drops**

0000	0100	0200	0300	0400	0500	0600	0700	0800	0900	1000	1100	1200	1300	1400	1500	1600	1700	1800	1900	2000	2100	2200	2300	
39	29	33	66	186	599	1353	1844	1142	668	540	536	507	528	521	583	564	522	385	228	173	168	124	73	
8	3	6	12	10	105	255	468	359	176	120	134	122	132	122	139	162	124	118	83	44	46	30	22	6
16	7	8	20	47	112	361	458	325	194	162	135	118	122	130	136	132	142	108	60	43	46	42	14	19
6	12	8	22	71	177	307	460	252	154	78	141	141	146	136	180	134	128	66	52	48	36	33	23	7
9	7	11	12	58	205	430	458	206	144	180	126	126	128	133	128	136	128	93	33	38	40	19	14	11

AM Peak 0700 - 0800 (1844), AM PHF=0.99 PM Peak 1515 - 1615 (606), PM PHF=0.84



# Southern Traffic Services, Inc.

## Classification Count

**US 41 between Gibsonton Drive & CR 676A (Madison Avenue) Northbound 27.87745 , -82.39227**

**Datasets:**

**Site:** [14] !6529  
**Site:** [14] !4206  
**Direction:** 1 - North bound, A hit first., Lane: 1  
**Survey Duration:** 6:50 Monday, January 07, 2013 => 12:23 Friday, January 11, 2013  
**File:** G:\DATA\2013\Private\13015\diego\Data 1-7-13\UM14 NB Slow.eco (Plus)  
**Identifier:** P321CE0K MC56-L4 [MC55] (c)Microcom 19Sep03  
**Algorithm:** Factory default  
**Data type:** Axle sensors - Paired (Class, Speed, Count)

**Profile:**

**Filter time:** 0:00 Tuesday, January 08, 2013 => 0:00 Friday, January 11, 2013  
**Included classes:** 1, 2, 3, 4, 5, 6, 7, 8, 9, 10, 11, 12, 13, 14  
**Speed range:** 0 - 100 mph.  
**Direction:** North (bound)

**Tuesday, January 08, 2013**

Time	Total	Cls 1	Cls 2	Cls 3	Cls 4	Cls 5	Cls 6	Cls 7	Cls 8	Cls 9	Cls 10	Cls 11	Cls 12	Cls 13	Cls 14
0000	10	0	8	1	0	0	0	0	1	0	0	0	0	0	0
0015	10	0	7	3	0	0	0	0	0	0	0	0	0	0	0
0030	11	0	5	3	1	0	1	0	0	1	0	0	0	0	0
0045	10	0	4	2	0	1	0	0	0	3	0	0	0	0	0
0100	10	0	6	1	0	1	0	0	0	2	0	0	0	0	0
0115	11	0	8	1	0	0	0	0	0	2	0	0	0	0	0
0130	8	0	5	2	0	0	0	0	0	1	0	0	0	0	0
0145	5	0	4	1	0	0	0	0	0	0	0	0	0	0	0
0200	11	0	8	1	0	0	0	0	0	2	0	0	0	0	0
0215	4	0	2	2	0	0	0	0	0	0	0	0	0	0	0
0230	7	0	6	0	0	0	0	0	0	1	0	0	0	0	0
0245	6	0	5	1	0	0	0	0	0	0	0	0	0	0	0
0300	14	0	9	4	0	0	0	0	0	1	0	0	0	0	0
0315	22	0	14	5	0	1	0	0	0	2	0	0	0	0	0
0330	25	0	15	9	0	0	0	0	0	1	0	0	0	0	0
0345	20	0	13	5	0	0	0	0	0	2	0	0	0	0	0
0400	21	0	16	4	0	0	0	0	0	1	0	0	0	0	0
0415	37	0	24	12	0	0	0	0	0	1	0	0	0	0	0
0430	50	0	31	17	0	0	0	0	1	1	0	0	0	0	0
0445	57	2	37	16	0	0	2	0	0	0	0	0	0	0	0
0500	106	2	80	19	0	3	0	0	1	1	0	0	0	0	0
0515	136	3	90	33	1	5	1	0	0	3	0	0	0	0	0
0530	173	4	114	54	0	0	0	0	0	1	0	0	0	0	0
0545	189	3	121	57	0	3	1	0	1	3	0	0	0	0	0
0600	246	3	167	67	0	3	1	0	2	3	0	0	0	0	0
0615	259	4	162	77	1	7	2	1	0	4	1	0	0	0	0
0630	435	1	295	120	0	5	1	2	5	6	0	0	0	0	0
0645	461	4	322	115	0	12	1	0	2	5	0	0	0	0	0
0700	415	1	313	91	0	6	0	0	2	2	0	0	0	0	0
0715	471	4	364	89	0	7	0	0	2	5	0	0	0	0	0
0730	484	5	353	104	0	10	3	0	3	6	0	0	0	0	0
0745	422	4	296	97	0	13	1	2	3	6	0	0	0	0	0
0800	358	3	259	83	0	7	2	0	2	2	0	0	0	0	0
0815	305	2	196	78	1	9	6	1	8	3	1	0	0	0	0
0830	277	2	140	107	0	14	5	0	4	2	3	0	0	0	0
0845	221	0	107	91	0	11	6	1	3	1	1	0	0	0	0
0900	133	1	67	42	0	13	3	0	5	1	1	0	0	0	0
0915	208	3	111	64	1	12	3	0	6	4	3	0	0	1	0
0930	182	0	96	67	0	6	5	2	1	5	0	0	0	0	0
0945	152	2	65	57	0	9	9	0	6	4	0	0	0	0	0
1000	151	0	74	58	0	6	7	0	3	2	1	0	0	0	0
1015	155	1	79	55	0	4	6	2	3	1	2	0	0	2	0

1030	149	0	83	51	1	2	3	2	2	4	1	0	0	0	0
1045	134	1	63	52	1	3	4	0	5	3	0	0	0	2	0
1100	127	2	61	42	0	10	3	2	3	3	1	0	0	0	0
1115	148	0	69	59	0	9	5	1	2	2	1	0	0	0	0
1130	126	1	50	52	0	5	4	1	8	4	0	0	0	1	0
1145	129	0	54	50	0	7	6	5	3	4	0	0	0	0	0
1200	125	0	51	51	0	9	6	0	4	4	0	0	0	0	0
1215	134	0	61	49	1	5	7	0	7	3	1	0	0	0	0
1230	151	2	65	60	0	9	7	1	3	3	1	0	0	0	0
1245	143	2	71	44	0	8	5	1	8	4	0	0	0	0	0
1300	156	2	68	59	0	11	13	0	1	2	0	0	0	0	0
1315	32	0	16	10	0	1	2	0	3	0	0	0	0	0	0
1330	219	1	99	76	0	19	12	1	5	6	0	0	0	0	0
1345	146	0	67	51	1	8	5	0	9	4	0	0	0	1	0
1400	108	3	51	33	1	8	4	2	2	4	0	0	0	0	0
1415	145	1	61	56	0	8	4	1	7	7	0	0	0	0	0
1430	136	3	69	45	0	9	3	0	4	3	0	0	0	0	0
1445	129	1	52	43	0	9	8	0	9	6	1	0	0	0	0
1500	161	1	71	60	0	17	5	0	5	2	0	0	0	0	0
1515	130	2	70	40	0	8	3	1	4	2	0	0	0	0	0
1530	165	1	94	57	0	6	2	0	3	2	0	0	0	0	0
1545	128	1	76	39	0	4	1	1	5	0	0	0	0	1	0
1600	124	1	65	36	0	5	3	1	7	6	0	0	0	0	0
1615	143	1	93	33	0	6	1	2	4	3	0	0	0	0	0
1630	137	0	89	31	0	7	0	0	5	4	0	0	0	1	0
1645	119	1	80	27	0	2	3	0	5	1	0	0	0	0	0
1700	128	0	78	37	0	4	1	0	3	5	0	0	0	0	0
1715	146	1	85	48	0	3	3	0	3	2	1	0	0	0	0
1730	154	0	95	52	0	5	0	0	2	0	0	0	0	0	0
1745	149	0	98	34	0	12	1	0	4	0	0	0	0	0	0
1800	130	1	79	41	0	4	0	0	3	2	0	0	0	0	0
1815	101	0	63	32	0	2	0	0	2	2	0	0	0	0	0
1830	82	1	53	23	0	1	0	1	2	1	0	0	0	0	0
1845	76	1	40	28	0	3	0	0	1	2	0	0	0	1	0
1900	66	1	41	16	1	3	0	0	1	2	1	0	0	0	0
1915	53	2	35	12	0	3	0	0	0	1	0	0	0	0	0
1930	66	2	47	12	0	2	1	0	1	1	0	0	0	0	0
1945	28	0	20	7	0	0	0	0	0	1	0	0	0	0	0
2000	40	0	23	12	0	3	0	0	0	2	0	0	0	0	0
2015	34	0	20	12	0	1	0	0	0	1	0	0	0	0	0
2030	51	0	33	15	0	0	0	0	1	2	0	0	0	0	0
2045	31	0	19	6	0	2	0	0	1	3	0	0	0	0	0
2100	42	0	25	11	0	3	0	0	0	3	0	0	0	0	0
2115	44	0	29	11	0	2	0	0	0	2	0	0	0	0	0
2130	34	1	20	8	0	2	0	0	0	3	0	0	0	0	0
2145	34	0	24	7	0	0	0	0	0	3	0	0	0	0	0
2200	25	0	18	5	0	2	0	0	0	0	0	0	0	0	0
2215	32	0	23	6	0	1	0	0	0	2	0	0	0	0	0
2230	14	0	10	3	0	0	0	0	0	1	0	0	0	0	0
2245	27	0	19	6	0	0	0	0	1	1	0	0	0	0	0
2300	19	0	14	5	0	0	0	0	0	0	0	0	0	0	0
2315	20	1	11	6	0	1	0	0	0	1	0	0	0	0	0
2330	20	1	11	7	0	0	0	0	0	1	0	0	0	0	0
2345	10	0	10	0	0	0	0	0	0	0	0	0	0	0	0
<b>00-00</b>	<b>11488</b>	<b>93</b>	<b>6890</b>	<b>3383</b>	<b>11</b>	<b>422</b>	<b>191</b>	<b>34</b>	<b>212</b>	<b>221</b>	<b>21</b>	<b>0</b>	<b>0</b>	<b>10</b>	<b>0</b>

**Wednesday, January 09, 2013**

Time	Total	Cls 1	Cls 2	Cls 3	Cls 4	Cls 5	Cls 6	Cls 7	Cls 8	Cls 9	Cls 10	Cls 11	Cls 12	Cls 13	Cls 14
0000	15	0	11	1	0	1	0	0	0	2	0	0	0	0	0
0015	11	0	7	2	1	1	0	0	0	0	0	0	0	0	0
0030	13	0	7	4	0	0	0	0	0	2	0	0	0	0	0
0045	8	0	4	4	0	0	0	0	0	0	0	0	0	0	0
0100	8	0	7	0	0	0	0	0	0	1	0	0	0	0	0
0115	10	0	5	4	0	1	0	0	0	0	0	0	0	0	0
0130	8	0	4	1	0	0	2	0	0	1	0	0	0	0	0
0145	10	0	3	4	0	0	1	0	0	2	0	0	0	0	0
0200	8	0	5	0	0	0	0	0	0	3	0	0	0	0	0
0215	8	0	7	0	0	0	0	0	1	0	0	0	0	0	0
0230	11	0	5	3	0	0	1	0	2	0	0	0	0	0	0

0245	13	0	8	2	0	3	0	0	0	0	0	0	0	0
0300	7	0	5	2	0	0	0	0	0	0	0	0	0	0
0315	21	0	12	5	0	1	0	0	0	3	0	0	0	0
0330	29	0	20	7	0	0	0	0	0	2	0	0	0	0
0345	26	0	19	6	0	0	0	0	1	0	0	0	0	0
0400	26	1	11	11	0	0	0	0	0	3	0	0	0	0
0415	40	1	28	9	0	1	1	0	0	0	0	0	0	0
0430	59	3	38	16	0	0	0	0	0	2	0	0	0	0
0445	62	0	37	19	0	2	2	0	1	1	0	0	0	0
0500	114	7	70	30	0	6	1	0	0	0	0	0	0	0
0515	126	3	74	43	0	2	1	0	0	3	0	0	0	0
0530	187	4	115	58	0	3	0	0	1	6	0	0	0	0
0545	217	1	138	72	0	2	0	0	1	2	0	0	0	1
0600	266	6	175	68	0	10	1	0	1	5	0	0	0	0
0615	367	4	227	121	0	4	3	0	2	6	0	0	0	0
0630	389	7	261	104	1	8	0	0	4	3	0	0	0	1
0645	373	5	251	100	0	5	5	0	5	2	0	0	0	0
0700	424	5	312	92	0	9	1	0	3	2	0	0	0	0
0715	456	4	334	107	0	4	0	0	3	4	0	0	0	0
0730	486	7	352	108	0	8	6	0	3	2	0	0	0	0
0745	448	5	317	114	0	6	2	0	4	0	0	0	0	0
0800	335	8	230	81	0	7	1	0	4	3	0	0	0	1
0815	305	5	213	75	0	1	0	1	6	2	1	0	0	1
0830	257	1	179	60	0	9	0	0	5	3	0	0	0	0
0845	239	4	141	69	0	15	0	0	3	5	1	0	0	1
0900	191	1	126	48	0	7	0	0	5	4	0	0	0	0
0915	164	0	105	40	0	3	7	1	4	3	1	0	0	0
0930	152	1	77	51	0	7	4	1	4	4	3	0	0	0
0945	167	1	92	53	1	7	3	3	1	3	3	0	0	0
1000	154	3	83	45	0	8	3	1	4	6	1	0	0	0
1015	136	2	77	31	0	11	1	2	4	8	0	0	0	0
1030	116	2	68	32	0	4	5	0	2	3	0	0	0	0
1045	142	0	76	42	0	9	2	0	5	7	0	0	0	1
1100	126	0	76	32	0	5	2	1	4	6	0	0	0	0
1115	121	5	61	28	0	10	3	0	5	9	0	0	0	0
1130	144	2	78	43	1	4	5	0	7	4	0	0	0	0
1145	24	0	17	5	0	2	0	0	0	0	0	0	0	0
1200	199	0	108	51	1	12	7	2	7	11	0	0	0	0
1215	70	1	40	21	0	4	1	0	2	1	0	0	0	0
1230	184	3	105	45	0	8	8	1	4	10	0	0	0	0
1245	132	3	74	37	0	6	3	0	3	5	1	0	0	0
1300	133	1	64	48	0	3	2	0	7	7	1	0	0	0
1315	138	3	75	43	0	3	3	0	5	5	1	0	0	0
1330	115	1	60	39	0	5	2	0	4	4	0	0	0	0
1345	121	2	69	30	1	3	5	1	2	6	2	0	0	0
1400	158	2	90	39	0	7	4	2	6	7	1	0	0	0
1415	143	5	79	43	0	6	4	0	0	6	0	0	0	0
1430	132	2	75	42	0	3	1	0	5	3	1	0	0	0
1445	124	0	60	42	0	9	7	1	1	4	0	0	0	0
1500	146	4	77	46	1	7	6	0	4	1	0	0	0	0
1515	142	0	76	46	0	12	1	1	3	3	0	0	0	0
1530	149	2	85	40	0	5	1	2	8	5	1	0	0	0
1545	149	1	83	54	0	3	3	0	2	2	0	0	0	1
1600	139	1	82	43	0	3	3	0	2	4	1	0	0	0
1615	125	3	76	28	0	5	8	0	2	3	0	0	0	0
1630	143	1	85	35	0	6	6	0	4	4	1	0	0	1
1645	137	0	83	40	0	4	3	1	2	3	1	0	0	0
1700	148	1	90	38	0	4	5	0	5	4	1	0	0	0
1715	118	0	75	36	0	1	1	0	3	2	0	0	0	0
1730	138	1	87	40	0	2	4	0	3	1	0	0	0	0
1745	131	3	78	39	0	3	4	1	1	2	0	0	0	0
1800	106	1	65	30	0	3	1	0	2	3	1	0	0	0
1815	120	2	83	26	0	4	0	0	3	2	0	0	0	0
1830	108	4	65	27	0	5	1	0	4	2	0	0	0	0
1845	102	3	62	30	0	4	0	0	1	2	0	0	0	0
1900	72	0	53	15	0	1	3	0	0	0	0	0	0	0
1915	82	2	51	24	0	0	1	0	2	2	0	0	0	0
1930	53	1	31	13	1	5	0	0	1	1	0	0	0	0
1945	35	2	23	9	0	0	0	0	0	1	0	0	0	0
2000	39	0	30	6	0	1	0	0	1	1	0	0	0	0

2015	38	0	28	7	0	0	0	0	1	2	0	0	0	0	0
2030	46	2	31	11	0	1	0	0	0	1	0	0	0	0	0
2045	35	0	29	5	0	0	0	0	0	1	0	0	0	0	0
2100	50	0	31	16	0	0	0	0	0	3	0	0	0	0	0
2115	55	2	38	13	0	0	0	0	0	2	0	0	0	0	0
2130	40	0	34	5	0	0	0	0	1	0	0	0	0	0	0
2145	31	0	25	6	0	0	0	0	0	0	0	0	0	0	0
2200	38	0	29	7	0	1	0	0	0	1	0	0	0	0	0
2215	34	0	29	4	0	0	0	0	0	1	0	0	0	0	0
2230	26	0	18	5	0	1	0	0	0	2	0	0	0	0	0
2245	26	0	15	10	0	0	0	0	0	1	0	0	0	0	0
2300	23	0	18	3	0	2	0	0	0	0	0	0	0	0	0
2315	15	0	9	4	0	0	0	0	0	2	0	0	0	0	0
2330	13	0	7	5	0	1	0	0	0	0	0	0	0	0	0
2345	16	0	12	3	0	0	0	0	1	0	0	0	0	0	0
<b>00-00</b>	<b>11536</b>	<b>157</b>	<b>7260</b>	<b>3101</b>	<b>8</b>	<b>339</b>	<b>161</b>	<b>22</b>	<b>197</b>	<b>260</b>	<b>23</b>	<b>0</b>	<b>0</b>	<b>8</b>	<b>0</b>

**Thursday, January 10, 2013**

Time	Total	Cls													
		1	2	3	4	5	6	7	8	9	10	11	12	13	14
0000	8	0	5	1	0	1	0	0	1	0	0	0	0	0	0
0015	16	0	11	5	0	0	0	0	0	0	0	0	0	0	0
0030	6	0	4	2	0	0	0	0	0	0	0	0	0	0	0
0045	9	1	6	2	0	0	0	0	0	0	0	0	0	0	0
0100	3	0	1	1	0	0	0	0	0	1	0	0	0	0	0
0115	7	0	2	2	0	1	0	0	0	2	0	0	0	0	0
0130	12	0	7	4	0	0	0	0	0	1	0	0	0	0	0
0145	7	0	4	1	0	0	0	0	0	2	0	0	0	0	0
0200	6	0	4	2	0	0	0	0	0	0	0	0	0	0	0
0215	8	0	7	1	0	0	0	0	0	0	0	0	0	0	0
0230	8	0	4	1	0	1	1	0	0	1	0	0	0	0	0
0245	11	0	7	4	0	0	0	0	0	0	0	0	0	0	0
0300	12	1	9	1	0	0	0	0	0	1	0	0	0	0	0
0315	20	0	13	4	0	2	0	0	0	1	0	0	0	0	0
0330	22	1	13	5	0	1	0	0	0	2	0	0	0	0	0
0345	12	0	5	6	0	0	0	0	0	1	0	0	0	0	0
0400	10	0	7	3	0	0	0	0	0	0	0	0	0	0	0
0415	47	1	30	12	0	1	1	0	0	2	0	0	0	0	0
0430	71	1	43	24	0	1	0	0	0	2	0	0	0	0	0
0445	58	1	31	20	0	2	3	0	0	1	0	0	0	0	0
0500	105	6	66	25	0	1	3	0	1	2	1	0	0	0	0
0515	112	2	70	35	0	3	1	0	0	1	0	0	0	0	0
0530	177	4	96	64	0	5	0	0	1	7	0	0	0	0	0
0545	205	6	131	64	1	1	0	0	2	0	0	0	0	0	0
0600	255	1	176	70	0	7	0	0	1	0	0	0	0	0	0
0615	363	3	225	117	0	10	1	0	2	5	0	0	0	0	0
0630	305	4	213	80	0	4	1	0	2	1	0	0	0	0	0
0645	430	8	292	115	1	10	3	0	0	1	0	0	0	0	0
0700	468	6	337	112	0	8	0	0	4	1	0	0	0	0	0
0715	458	3	327	107	0	9	2	0	4	6	0	0	0	0	0
0730	461	4	318	124	0	5	0	0	7	3	0	0	0	0	0
0745	457	9	321	111	0	8	1	0	6	1	0	0	0	0	0
0800	359	5	247	90	0	9	3	0	3	2	0	0	0	0	0
0815	325	0	232	76	0	8	3	0	1	5	0	0	0	0	0
0830	253	2	159	70	1	10	2	0	6	3	0	0	0	0	0
0845	205	1	131	59	2	6	0	0	2	3	1	0	0	0	0
0900	176	1	115	47	0	3	4	1	2	3	0	0	0	0	0
0915	194	2	121	48	0	5	3	0	7	8	0	0	0	0	0
0930	154	6	85	39	0	7	5	0	2	8	0	0	0	2	0
0945	145	1	80	51	0	5	0	0	3	5	0	0	0	0	0
1000	119	2	68	34	0	3	3	1	4	3	1	0	0	0	0
1015	162	1	91	46	0	9	2	0	7	6	0	0	0	0	0
1030	78	1	43	25	0	0	1	0	4	4	0	0	0	0	0
1045	181	1	103	45	0	9	7	0	5	10	1	0	0	0	0
1100	134	0	76	42	0	5	3	0	6	2	0	0	0	0	0
1115	134	2	83	27	0	5	2	0	9	5	1	0	0	0	0
1130	141	2	72	37	0	10	6	0	7	5	2	0	0	0	0
1145	126	4	76	32	0	5	1	1	1	5	1	0	0	0	0
1200	122	0	73	29	0	8	1	0	5	6	0	0	0	0	0
1215	118	1	63	39	0	6	1	0	3	5	0	0	0	0	0

1230	141	4	74	41	0	7	2	0	5	8	0	0	0	0	0
1245	126	2	69	38	1	4	2	0	6	4	0	0	0	0	0
1300	132	4	74	33	0	8	3	0	1	7	2	0	0	0	0
1315	122	2	68	34	0	6	4	1	3	4	0	0	0	0	0
1330	146	2	67	42	1	11	1	0	10	10	2	0	0	0	0
1345	128	1	73	31	2	6	6	0	6	3	0	0	0	0	0
1400	122	2	63	36	0	9	5	1	3	2	1	0	0	0	0
1415	130	3	72	38	0	6	4	1	2	3	1	0	0	0	0
1430	138	0	69	47	0	6	7	0	6	3	0	0	0	0	0
1445	131	0	71	41	0	9	7	0	1	2	0	0	0	0	0
1500	139	1	77	34	0	10	5	1	4	6	1	0	0	0	0
1515	136	1	64	43	0	10	8	0	6	4	0	0	0	0	0
1530	180	0	99	61	0	6	4	0	3	7	0	0	0	0	0
1545	128	0	72	35	0	3	10	0	1	6	1	0	0	0	0
1600	162	2	95	44	0	7	5	0	7	2	0	0	0	0	0
1615	132	4	79	29	1	7	6	0	2	4	0	0	0	0	0
1630	135	3	80	35	0	6	3	0	2	5	1	0	0	0	0
1645	135	1	79	39	0	3	0	1	5	6	1	0	0	0	0
1700	124	2	78	33	0	3	2	0	0	5	1	0	0	0	0
1715	142	3	95	38	0	2	0	0	2	1	1	0	0	0	0
1730	128	1	85	31	0	5	0	0	2	4	0	0	0	0	0
1745	128	2	77	44	0	4	0	0	1	0	0	0	0	0	0
1800	118	0	77	34	0	4	0	0	2	1	0	0	0	0	0
1815	108	1	71	31	0	1	0	0	1	3	0	0	0	0	0
1830	66	0	44	19	0	0	0	0	2	1	0	0	0	0	0
1845	94	1	56	29	0	4	0	0	1	2	0	0	0	1	0
1900	82	2	47	30	0	3	0	0	0	0	0	0	0	0	0
1915	60	2	39	11	0	6	0	0	0	2	0	0	0	0	0
1930	52	0	30	15	0	4	2	0	0	1	0	0	0	0	0
1945	33	0	23	8	0	0	0	0	0	1	1	0	0	0	0
2000	44	2	26	13	0	0	1	0	0	2	0	0	0	0	0
2015	43	0	24	11	0	2	0	0	3	1	2	0	0	0	0
2030	48	1	33	9	0	0	1	0	1	2	1	0	0	0	0
2045	38	3	21	11	0	1	0	0	0	2	0	0	0	0	0
2100	46	0	32	11	0	1	1	0	1	0	0	0	0	0	0
2115	46	2	35	6	0	1	0	0	0	2	0	0	0	0	0
2130	36	1	31	3	0	0	1	0	0	0	0	0	0	0	0
2145	40	1	33	4	0	1	1	0	0	0	0	0	0	0	0
2200	30	0	19	8	0	2	0	0	1	0	0	0	0	0	0
2215	42	1	30	7	0	0	2	0	0	2	0	0	0	0	0
2230	33	1	20	8	0	1	1	0	0	2	0	0	0	0	0
2245	19	0	12	4	0	2	0	0	0	0	1	0	0	0	0
2300	22	0	13	5	0	0	2	0	1	1	0	0	0	0	0
2315	14	0	7	6	0	0	0	0	0	1	0	0	0	0	0
2330	23	0	15	7	0	0	0	0	1	0	0	0	0	0	0
2345	14	1	11	2	0	0	0	0	0	0	0	0	0	0	0
00-00	11411	153	7132	3100	10	365	160	8	200	255	25	0	0	3	0

**Grand Total**

Time	Total	Cls 1	Cls 2	Cls 3	Cls 4	Cls 5	Cls 6	Cls 7	Cls 8	Cls 9	Cls 10	Cls 11	Cls 12	Cls 13	Cls 14
--	34435	403	21282	9584	29	1126	512	64	609	736	69	0	0	21	0

## Southern Traffic Services, Inc. Class Speed Matrix

**US 41 between Gibsonton Drive & CR 676A (Madison Avenue)      Southbound      27.87745 , -82.39227**

**Datasets:**

**Site:** [14] !8029  
**Site:** [14] !7058  
**Direction:** 3 - South bound, A hit first., Lane: 1  
**Survey Duration:** 6:51 Monday, January 07, 2013 => 12:25 Friday, January 11, 2013  
**File:** G:\DATA\2013\Private\13015\diego\Data 1-7-13\UM14 SB Slow.eco (Plus)  
**Identifier:** U327QAYJ MC56-L5 [MC55] (c)Microcom 19Oct04  
**Algorithm:** Factory default  
**Data type:** Axle sensors - Paired (Class, Speed, Count)

**Profile:**

**Filter time:** 0:00 Tuesday, January 08, 2013 => 0:00 Friday, January 11, 2013  
**Included classes:** 1, 2, 3, 4, 5, 6, 7, 8, 9, 10, 11, 12, 13, 14  
**Speed range:** 0 - 100 mph.  
**Direction:** South (bound)

Speed (mph)	Class														Speed Totals	
	1	2	3	4	5	6	7	8	9	10	11	12	13	14		
0 - 5	1	5	1	1	1	.	.	.	.	.	.	.	.	.	9	0.0%
5 - 10	1	14	12	.	2	2	.	.	.	.	.	.	.	.	31	0.1%
10 - 15	5	42	25	.	3	8	1	1	.	.	.	.	.	.	85	0.2%
15 - 20	6	80	34	.	4	2	2	3	3	1	.	.	.	.	135	0.4%
20 - 25	5	119	52	.	4	5	.	2	6	.	.	.	.	.	193	0.5%
25 - 30	5	143	48	.	12	2	.	1	11	1	.	.	1	.	224	0.6%
30 - 35	8	156	76	1	22	1	3	3	16	.	.	.	.	.	286	0.8%
35 - 40	4	166	81	3	18	6	3	6	40	2	.	.	1	.	330	0.9%
40 - 45	5	255	99	7	24	23	10	15	67	.	.	.	.	.	505	1.4%
45 - 50	16	821	387	4	53	48	13	56	80	6	1	.	4	.	1489	4.0%
50 - 55	45	2903	1316	6	201	94	16	138	138	25	.	.	2	.	4884	13.1%
55 - 60	96	6584	3044	8	373	120	58	190	299	33	4	1	6	.	10816	28.9%
60 - 65	92	6847	3146	13	388	82	24	148	199	20	1	1	1	.	10962	29.3%
65 - 70	80	3323	1687	2	172	33	2	52	57	8	1	2	2	.	5421	14.5%
70 - 75	37	950	490	2	54	7	.	8	7	.	.	.	.	.	1555	4.2%
75 - 80	16	197	105	.	12	.	.	1	1	.	.	.	.	.	332	0.9%
80 - 85	9	49	30	.	2	1	.	.	.	.	.	.	.	.	91	0.2%
85 - 90	6	15	12	.	2	.	.	.	.	.	.	.	.	.	35	0.1%
90 - 95	2	4	.	.	.	.	.	.	.	.	.	.	.	.	6	0.0%
95 - 100	.	.	1	.	.	.	.	.	.	.	.	.	.	.	1	0.0%
	<b>439</b>	<b>22673</b>	<b>10646</b>	<b>47</b>	<b>1347</b>	<b>434</b>	<b>132</b>	<b>624</b>	<b>924</b>	<b>96</b>	<b>7</b>	<b>4</b>	<b>17</b>	<b>0</b>	<b>37390</b>	
	<b>1.2%</b>	<b>60.6%</b>	<b>28.5%</b>	<b>0.1%</b>	<b>3.6%</b>	<b>1.2%</b>	<b>0.4%</b>	<b>1.7%</b>	<b>2.5%</b>	<b>0.3%</b>	<b>0.0%</b>	<b>0.0%</b>	<b>0.0%</b>	<b>0.0%</b>		
	<b>Class Totals</b>															

# Southern Traffic Services, Inc.

## Vehicle Counts

**US 41 between Gibsonton Drive & CR 676A (Madison Avenue) Southbound 27.87745, -82.39227**

**Datasets:**

**Site:** [14] !8029  
**Site:** [14] !7058  
**Direction:** 3 - South bound, A hit first., Lane: 1  
**Survey Duration:** 6:51 Monday, January 07, 2013 => 12:25 Friday, January 11, 2013  
**File:** G:\DATA\2013\Private\13015\diego\Data 1-7-13\UM14 SB Slow.eco (Plus)  
**Identifier:** U327QAYJ MC56-L5 [MC55] (c)Microcom 19Oct04  
**Algorithm:** Factory default  
**Data type:** Axle sensors - Paired (Class, Speed, Count)

**Profile:**

**Filter time:** 0:00 Tuesday, January 08, 2013 => 1:00 Friday, January 11, 2013  
**Included classes:** 1, 2, 3, 4, 5, 6, 7, 8, 9, 10, 11, 12, 13, 14  
**Speed range:** 0 - 100 mph.  
**Direction:** South (bound)  
**Separation:** All - (Headway)  
**Name:** Factory default profile  
**Scheme:** Vehicle classification (FLDOT)  
**Units:** Non metric (ft, mi, ft/s, mph, lb, ton)  
**In profile:** Vehicles = 37390

**Tuesday, January 08, 2013 - Total=12458, 15 minute drops**

0000	0100	0200	0300	0400	0500	0600	0700	0800	0900	1000	1100	1200	1300	1400	1500	1600	1700	1800	1900	2000	2100	2200	2300	
168	76	52	63	79	165	334	415	458	445	432	517	478	595	577	1114	1532	1829	1241	637	472	341	247	191	
70	18	15	10	23	28	88	100	121	115	98	109	112	169	153	220	323	450	409	196	131	85	94	52	30
52	27	16	15	15	37	66	94	126	104	125	134	151	39	176	270	383	459	330	143	141	83	60	53	26
27	16	12	21	19	45	91	106	116	117	108	123	119	237	143	285	396	474	290	156	104	80	62	51	22
19	15	9	17	22	55	89	115	95	109	101	151	96	150	105	339	430	446	212	142	96	93	31	35	13

AM Peak 1130 - 1230 (537), AM PHF=0.89 PM Peak 1700 - 1800 (1829), PM PHF=0.96

**Wednesday, January 09, 2013 - Total=12477, 15 minute drops**

0000	0100	0200	0300	0400	0500	0600	0700	0800	0900	1000	1100	1200	1300	1400	1500	1600	1700	1800	1900	2000	2100	2200	2300	
91	85	58	45	81	192	334	443	474	436	443	453	585	522	665	1066	1461	1826	1220	584	473	392	309	239	
30	28	17	13	20	20	83	107	114	123	122	129	153	132	163	213	330	484	396	154	133	104	79	64	37
26	18	25	11	19	38	65	109	133	113	108	143	146	143	156	232	373	488	332	145	119	66	94	58	30
22	23	8	17	21	64	108	125	124	84	102	141	149	139	181	258	377	420	269	162	123	133	76	54	28
13	16	8	4	21	70	78	102	103	116	111	40	137	108	165	363	381	434	223	123	98	89	60	63	24

AM Peak 1045 - 1145 (524), AM PHF=0.92 PM Peak 1700 - 1800 (1826), PM PHF=0.94

**Thursday, January 10, 2013 - Total=12455, 15 minute drops**

0000	0100	0200	0300	0400	0500	0600	0700	0800	0900	1000	1100	1200	1300	1400	1500	1600	1700	1800	1900	2000	2100	2200	2300	
119	81	60	46	81	165	364	452	356	484	440	455	532	510	702	1055	1480	1786	1249	669	488	347	331	203	
37	28	23	11	20	30	95	113	102	170	93	110	132	140	165	206	359	461	373	213	128	79	76	58	40
30	18	11	10	19	31	102	106	106	89	108	92	144	106	166	243	350	470	315	200	133	119	84	48	38
28	24	14	12	23	44	76	123	103	105	95	130	152	139	179	252	390	466	313	139	108	69	99	54	35
24	11	12	13	19	60	91	110	45	120	144	123	104	125	192	354	381	389	248	117	119	80	72	43	22

AM Peak 1145 - 1245 (551), AM PHF=0.91 PM Peak 1700 - 1800 (1786), PM PHF=0.95

# Southern Traffic Services, Inc.

## Classification Count

**US 41 between Gibsonton Drive & CR 676A (Madison Avenue)      Southbound      27.87745 , -82.39227**

**Datasets:**

**Site:** [14] !8029  
**Site:** [14] !7058  
**Direction:** 3 - South bound, A hit first., Lane: 1  
**Survey Duration:** 6:51 Monday, January 07, 2013 => 12:25 Friday, January 11, 2013  
**File:** G:\DATA\2013\Private\13015\diego\Data 1-7-13\UM14 SB Slow.eco (Plus)  
**Identifier:** U327QAYJ MC56-L5 [MC55] (c)Microcom 19Oct04  
**Algorithm:** Factory default  
**Data type:** Axle sensors - Paired (Class, Speed, Count)

**Profile:**

**Filter time:** 0:00 Tuesday, January 08, 2013 => 0:00 Friday, January 11, 2013  
**Included classes:** 1, 2, 3, 4, 5, 6, 7, 8, 9, 10, 11, 12, 13, 14  
**Speed range:** 0 - 100 mph.  
**Direction:** South (bound)

**Tuesday, January 08, 2013**

Time	Total	Cls 1	Cls 2	Cls 3	Cls 4	Cls 5	Cls 6	Cls 7	Cls 8	Cls 9	Cls 10	Cls 11	Cls 12	Cls 13	Cls 14
0000	69	0	54	14	0	0	1	0	0	0	0	0	0	0	0
0015	52	0	36	15	0	0	0	0	0	1	0	0	0	0	0
0030	27	0	17	7	0	1	0	0	0	2	0	0	0	0	0
0045	19	0	13	3	0	3	0	0	0	0	0	0	0	0	0
0100	18	0	12	5	0	1	0	0	0	0	0	0	0	0	0
0115	27	1	18	4	0	0	0	0	0	3	0	0	0	1	0
0130	16	0	8	6	0	0	0	1	0	1	0	0	0	0	0
0145	15	0	10	2	1	1	0	0	0	0	0	0	1	0	0
0200	15	0	10	3	0	1	0	0	0	1	0	0	0	0	0
0215	16	0	8	6	0	0	0	0	0	1	0	0	1	0	0
0230	12	0	6	5	0	0	0	0	0	1	0	0	0	0	0
0245	9	0	7	1	0	1	0	0	0	0	0	0	0	0	0
0300	10	0	6	3	0	0	0	0	0	1	0	0	0	0	0
0315	15	0	7	4	0	0	0	0	0	4	0	0	0	0	0
0330	21	0	10	8	0	0	0	0	0	3	0	0	0	0	0
0345	17	0	10	4	0	0	0	0	1	2	0	0	0	0	0
0400	23	0	5	6	0	1	1	0	3	6	1	0	0	0	0
0415	15	0	6	4	0	0	1	0	1	3	0	0	0	0	0
0430	20	0	12	5	0	0	0	0	1	2	0	0	0	0	0
0445	21	0	7	7	0	1	1	0	1	4	0	0	0	0	0
0500	28	0	12	10	1	0	0	0	0	5	0	0	0	0	0
0515	37	0	17	9	1	1	4	0	1	4	0	0	0	0	0
0530	45	1	14	21	0	2	3	0	0	4	0	0	0	0	0
0545	55	0	26	20	0	1	4	0	1	3	0	0	0	0	0
0600	88	0	34	43	0	4	4	0	1	2	0	0	0	0	0
0615	66	0	30	24	0	5	2	0	1	3	1	0	0	0	0
0630	91	4	41	35	0	3	3	0	0	4	1	0	0	0	0
0645	89	0	37	41	0	1	4	2	1	2	1	0	0	0	0
0700	100	0	62	19	0	2	5	0	6	6	0	0	0	0	0
0715	94	0	50	22	1	7	3	1	2	8	0	0	0	0	0
0730	106	0	46	40	0	9	1	0	2	7	1	0	0	0	0
0745	116	0	51	36	0	11	7	0	6	3	2	0	0	0	0
0800	120	0	55	38	0	10	2	2	6	3	3	0	0	1	0
0815	126	0	46	54	1	8	4	3	3	6	1	0	0	0	0
0830	116	1	52	41	1	8	0	1	4	7	0	0	0	1	0
0845	95	2	44	27	0	9	7	0	2	2	1	0	0	1	0
0900	115	2	42	42	0	10	4	1	7	5	2	0	0	0	0
0915	104	0	49	32	2	7	2	6	1	4	1	0	0	0	0
0930	119	1	59	42	0	5	1	0	3	7	1	0	0	0	0
0945	107	0	45	34	0	9	8	3	3	4	1	0	0	0	0
1000	98	0	47	32	1	6	1	1	3	5	2	0	0	0	0
1015	125	0	60	40	0	10	2	3	4	5	1	0	0	0	0



1030	108	0	45	35	0	10	6	2	8	1	1	0	0	0	0
1045	101	0	40	39	0	7	2	2	3	8	0	0	0	0	0
1100	109	2	57	36	0	4	1	1	1	7	0	0	0	0	0
1115	134	1	51	44	0	10	5	9	3	10	1	0	0	0	0
1130	123	2	70	32	0	6	3	1	5	4	0	0	0	0	0
1145	151	2	72	38	0	8	5	2	10	11	3	0	0	0	0
1200	112	0	49	44	0	6	5	0	3	5	0	0	0	0	0
1215	151	3	73	52	0	13	1	1	4	2	2	0	0	0	0
1230	119	0	57	38	0	8	2	4	3	7	0	0	0	0	0
1245	96	2	55	24	0	1	2	3	2	6	1	0	0	0	0
1300	170	2	87	51	0	8	4	2	10	6	0	0	0	0	0
1315	38	0	25	10	0	2	0	0	1	0	0	0	0	0	0
1330	237	0	134	60	0	19	4	4	5	9	2	0	0	0	0
1345	151	1	69	56	0	10	2	4	3	6	0	0	0	0	0
1400	153	6	80	42	1	6	7	5	3	2	1	0	0	0	0
1415	175	2	104	47	0	11	2	1	3	5	0	0	0	0	0
1430	143	0	73	50	0	6	0	6	3	5	0	0	0	0	0
1445	105	3	51	31	0	5	4	1	5	5	0	0	0	0	0
1500	220	0	133	61	0	13	2	3	5	3	0	0	0	0	0
1515	270	5	170	79	0	12	2	0	1	1	0	0	0	0	0
1530	285	3	176	88	1	9	1	1	3	3	0	0	0	0	0
1545	339	1	202	115	2	10	1	0	5	3	0	0	0	0	0
1600	323	3	195	103	0	12	0	1	8	1	0	0	0	0	0
1615	383	5	250	103	0	11	3	0	7	4	0	0	0	0	0
1630	398	3	288	91	0	11	0	0	1	4	0	0	0	0	0
1645	428	2	273	127	0	16	1	1	4	3	0	0	0	1	0
1700	450	5	301	119	0	17	1	0	2	5	0	0	0	0	0
1715	459	3	327	108	0	15	2	0	1	3	0	0	0	0	0
1730	474	6	342	112	0	7	3	0	1	3	0	0	0	0	0
1745	446	2	317	113	0	10	1	0	2	1	0	0	0	0	0
1800	409	2	277	115	1	11	0	0	3	0	0	0	0	0	0
1815	331	5	223	93	0	5	0	0	1	4	0	0	0	0	0
1830	290	5	201	75	0	6	0	0	3	0	0	0	0	0	0
1845	211	0	139	62	0	5	1	1	2	1	0	0	0	0	0
1900	196	6	137	47	0	5	1	0	0	0	0	0	0	0	0
1915	143	0	107	32	0	2	0	0	2	0	0	0	0	0	0
1930	156	1	107	43	0	1	1	0	0	3	0	0	0	0	0
1945	142	0	98	38	0	2	0	0	3	1	0	0	0	0	0
2000	132	3	86	36	0	5	0	0	0	1	0	0	0	1	0
2015	140	0	101	36	0	1	0	0	1	1	0	0	0	0	0
2030	104	0	79	23	0	1	0	0	0	1	0	0	0	0	0
2045	96	0	70	24	0	0	0	0	0	2	0	0	0	0	0
2100	85	3	48	30	0	1	0	1	1	0	1	0	0	0	0
2115	83	3	52	23	0	1	0	0	2	1	0	1	0	0	0
2130	81	0	54	21	0	4	0	0	2	0	0	0	0	0	0
2145	92	0	66	22	0	1	0	0	3	0	0	0	0	0	0
2200	94	0	65	24	0	1	0	0	1	3	0	0	0	0	0
2215	60	1	42	16	0	1	0	0	0	0	0	0	0	0	0
2230	62	5	36	18	0	1	0	0	1	1	0	0	0	0	0
2245	31	0	23	6	0	0	1	0	0	1	0	0	0	0	0
2300	52	0	36	14	0	1	0	0	0	1	0	0	0	0	0
2315	53	0	33	20	0	0	0	0	0	0	0	0	0	0	0
2330	51	1	35	13	0	1	1	0	0	0	0	0	0	0	0
2345	35	1	25	7	0	0	0	0	0	2	0	0	0	0	0
<b>00-00</b>	<b>12457</b>	<b>112</b>	<b>7487</b>	<b>3600</b>	<b>14</b>	<b>477</b>	<b>152</b>	<b>80</b>	<b>204</b>	<b>290</b>	<b>32</b>	<b>1</b>	<b>2</b>	<b>6</b>	<b>0</b>

**Wednesday, January 09, 2013**

<b>Time</b>	<b>Total</b>	<b>Cls</b>	<b>Cls</b>	<b>Cls</b>	<b>Cls</b>	<b>Cls</b>	<b>Cls</b>	<b>Cls</b>	<b>Cls</b>	<b>Cls</b>	<b>Cls</b>	<b>Cls</b>	<b>Cls</b>	<b>Cls</b>	<b>Cls</b>
		<b>1</b>	<b>2</b>	<b>3</b>	<b>4</b>	<b>5</b>	<b>6</b>	<b>7</b>	<b>8</b>	<b>9</b>	<b>10</b>	<b>11</b>	<b>12</b>	<b>13</b>	<b>14</b>
0000	30	0	22	6	0	0	0	0	1	1	0	0	0	0	0
0015	26	0	21	4	0	1	0	0	0	0	0	0	0	0	0
0030	22	0	13	8	0	1	0	0	0	0	0	0	0	0	0
0045	13	0	9	2	0	0	0	0	0	2	0	0	0	0	0
0100	28	0	22	6	0	0	0	0	0	0	0	0	0	0	0
0115	18	0	9	3	0	0	0	0	1	3	0	1	1	0	0
0130	23	0	13	5	0	2	0	0	0	3	0	0	0	0	0
0145	16	0	12	1	0	1	0	0	1	0	0	1	0	0	0
0200	17	1	7	4	0	0	0	0	1	4	0	0	0	0	0
0215	25	0	14	7	1	1	0	0	0	2	0	0	0	0	0
0230	8	0	6	1	0	0	0	0	0	1	0	0	0	0	0

0245	8	0	6	2	0	0	0	0	0	0	0	0	0	0
0300	13	0	9	4	0	0	0	0	0	0	0	0	0	0
0315	11	0	7	3	0	0	0	0	1	0	0	0	0	0
0330	17	0	6	8	0	1	0	0	2	0	0	0	0	0
0345	4	0	2	2	0	0	0	0	0	0	0	0	0	0
0400	20	0	7	7	0	1	0	1	1	3	0	0	0	0
0415	19	0	10	2	0	0	0	0	2	5	0	0	0	0
0430	21	0	12	2	0	1	0	0	2	4	0	0	0	0
0445	21	0	11	7	0	0	1	0	1	1	0	0	0	0
0500	20	0	10	6	0	1	0	0	0	3	0	0	0	0
0515	38	0	17	14	0	0	0	0	5	2	0	0	0	0
0530	64	1	15	24	0	0	12	0	0	11	1	0	0	0
0545	70	1	33	16	0	3	11	0	2	4	0	0	0	0
0600	83	0	40	28	0	2	7	0	0	6	0	0	0	0
0615	65	1	32	22	1	3	0	0	2	4	0	0	0	0
0630	108	0	57	29	0	8	7	0	2	5	0	0	0	0
0645	78	0	38	21	0	4	8	0	0	7	0	0	0	0
0700	108	0	60	29	1	1	4	2	3	8	0	0	0	0
0715	108	1	61	27	0	4	3	0	3	8	1	0	0	0
0730	125	0	66	33	0	6	1	1	5	12	1	0	0	0
0745	102	0	48	30	0	3	4	0	6	10	1	0	0	0
0800	116	0	60	35	0	11	1	0	5	4	0	0	0	0
0815	131	1	60	46	0	7	2	1	2	9	2	0	0	1
0830	124	3	56	34	0	6	6	1	5	9	4	0	0	0
0845	103	1	64	26	0	3	3	0	0	6	0	0	0	0
0900	123	3	55	40	0	9	2	1	4	9	0	0	0	0
0915	113	0	49	42	0	8	0	1	3	9	1	0	0	0
0930	84	0	46	27	0	2	1	0	5	2	0	0	0	1
0945	116	0	57	38	0	8	1	0	6	6	0	0	0	0
1000	122	0	55	42	0	14	0	0	1	8	2	0	0	0
1015	108	0	58	24	0	13	0	0	1	11	1	0	0	0
1030	102	0	54	31	0	7	3	0	2	5	0	0	0	0
1045	112	2	38	36	1	10	8	2	3	9	3	0	0	0
1100	128	2	60	47	0	5	2	1	2	7	2	0	0	0
1115	143	3	79	31	0	8	6	0	7	8	1	0	0	0
1130	141	0	73	34	0	17	1	0	8	6	2	0	0	0
1145	40	1	20	12	0	3	1	0	3	0	0	0	0	0
1200	153	1	81	44	0	10	5	1	4	5	1	0	0	1
1215	146	1	91	36	3	5	1	4	1	4	0	0	0	0
1230	149	1	80	51	0	7	1	0	2	7	0	0	0	0
1245	137	1	77	38	0	7	1	2	3	8	0	0	0	0
1300	133	5	66	39	0	5	2	3	9	4	0	0	0	0
1315	142	0	74	40	0	8	3	1	6	6	4	0	0	0
1330	139	3	76	42	0	7	1	1	5	4	0	0	0	0
1345	108	1	56	35	1	6	2	0	2	4	1	0	0	0
1400	163	4	101	42	0	9	0	0	2	5	0	0	0	0
1415	156	3	91	47	0	6	4	0	0	5	0	0	0	0
1430	181	3	108	51	2	8	1	0	2	6	0	0	0	0
1445	165	1	99	52	1	7	1	1	3	0	0	0	0	0
1500	213	1	126	63	0	5	2	2	9	4	1	0	0	0
1515	232	2	139	71	0	10	4	0	3	3	0	0	0	0
1530	258	0	153	92	0	6	1	0	2	4	0	0	0	0
1545	363	10	212	115	0	16	2	0	4	3	1	0	0	0
1600	330	4	196	107	0	12	1	0	7	3	0	0	0	0
1615	373	9	242	105	0	10	3	0	2	2	0	0	0	0
1630	377	7	249	103	2	8	6	0	1	1	0	0	0	0
1645	381	7	250	103	0	12	3	0	3	3	0	0	0	0
1700	484	5	338	123	1	12	0	0	4	1	0	0	0	0
1715	488	7	362	103	0	5	0	0	6	4	1	0	0	0
1730	421	2	296	113	0	4	1	0	2	3	0	0	0	0
1745	435	7	298	113	0	10	1	0	4	2	0	0	0	0
1800	396	2	270	110	1	10	0	0	2	1	0	0	0	0
1815	330	5	229	82	0	6	1	0	4	3	0	0	0	0
1830	269	1	184	73	1	5	2	0	0	3	0	0	0	0
1845	223	1	158	58	0	4	0	0	1	1	0	0	0	0
1900	154	0	103	44	0	6	0	0	0	1	0	0	0	0
1915	145	1	105	32	0	2	1	0	3	1	0	0	0	0
1930	162	4	105	47	0	4	0	0	1	1	0	0	0	0
1945	123	0	91	29	0	2	0	0	1	0	0	0	0	0
2000	133	2	90	34	0	2	1	0	0	4	0	0	0	0

2015	119	5	81	29	0	3	0	0	1	0	0	0	0	0	0
2030	123	3	76	41	0	3	0	0	0	0	0	0	0	0	0
2045	98	1	66	30	0	1	0	0	0	0	0	0	0	0	0
2100	104	2	70	29	0	2	0	0	0	1	0	0	0	0	0
2115	66	0	48	15	0	2	0	0	1	0	0	0	0	0	0
2130	134	2	102	28	0	0	0	0	1	1	0	0	0	0	0
2145	88	4	64	17	0	2	0	0	1	0	0	0	0	0	0
2200	79	0	64	13	0	0	0	0	1	1	0	0	0	0	0
2215	94	2	66	24	0	2	0	0	0	0	0	0	0	0	0
2230	76	5	48	18	0	4	0	0	0	1	0	0	0	0	0
2245	61	1	44	13	0	2	0	0	0	1	0	0	0	0	0
2300	64	1	46	15	0	1	0	0	0	1	0	0	0	0	0
2315	57	2	41	13	0	1	0	0	0	0	0	0	0	0	0
2330	54	2	36	12	0	1	0	0	0	3	0	0	0	0	0
2345	63	1	44	15	0	2	0	0	1	0	0	0	0	0	0
<b>00-00</b>	<b>12477</b>	<b>153</b>	<b>7671</b>	<b>3457</b>	<b>16</b>	<b>437</b>	<b>146</b>	<b>26</b>	<b>199</b>	<b>335</b>	<b>31</b>	<b>2</b>	<b>1</b>	<b>3</b>	<b>0</b>

**Thursday, January 10, 2013**

Time	Total	Cls													
		1	2	3	4	5	6	7	8	9	10	11	12	13	14
0000	37	1	25	10	0	0	0	0	0	1	0	0	0	0	0
0015	30	1	21	8	0	0	0	0	0	0	0	0	0	0	0
0030	28	1	17	8	0	0	0	0	0	2	0	0	0	0	0
0045	24	0	14	7	0	1	0	0	0	1	0	1	0	0	0
0100	28	1	19	6	0	1	0	0	0	1	0	0	0	0	0
0115	18	0	15	2	0	0	0	0	0	1	0	0	0	0	0
0130	24	0	13	6	0	1	0	0	1	1	0	1	1	0	0
0145	11	2	5	3	0	0	1	0	0	0	0	0	0	0	0
0200	23	2	16	4	0	0	0	0	0	1	0	0	0	0	0
0215	11	0	4	3	0	2	0	0	0	2	0	0	0	0	0
0230	14	0	6	4	0	1	0	0	0	3	0	0	0	0	0
0245	12	1	7	3	0	0	0	0	0	1	0	0	0	0	0
0300	11	0	8	0	0	0	0	0	0	3	0	0	0	0	0
0315	10	1	6	1	0	1	0	0	1	0	0	0	0	0	0
0330	12	0	3	4	0	0	1	0	1	3	0	0	0	0	0
0345	13	1	8	3	0	0	0	0	0	1	0	0	0	0	0
0400	20	0	8	2	0	3	0	0	0	7	0	0	0	0	0
0415	19	1	9	5	0	0	2	0	1	1	0	0	0	0	0
0430	23	0	15	3	0	0	1	0	1	3	0	0	0	0	0
0445	19	0	5	7	0	2	0	0	1	4	0	0	0	0	0
0500	30	2	8	9	2	0	2	0	3	4	0	0	0	0	0
0515	31	0	16	10	0	0	1	0	1	2	1	0	0	0	0
0530	44	0	17	17	0	2	3	0	0	5	0	0	0	0	0
0545	60	1	21	27	0	2	3	0	1	5	0	0	0	0	0
0600	95	0	41	31	0	3	8	0	3	9	0	0	0	0	0
0615	102	0	45	42	0	4	3	0	2	6	0	0	0	0	0
0630	76	0	34	26	0	4	5	1	1	5	0	0	0	0	0
0645	91	0	42	31	1	4	3	0	2	8	0	0	0	0	0
0700	113	1	63	22	1	5	7	0	7	6	0	0	0	1	0
0715	106	0	58	27	0	9	4	1	2	4	1	0	0	0	0
0730	123	1	60	39	0	4	3	0	5	10	1	0	0	0	0
0745	111	0	47	47	0	5	1	1	3	5	2	0	0	0	0
0800	102	2	51	36	0	8	1	0	1	1	1	0	0	1	0
0815	105	0	45	32	1	8	3	1	5	9	1	0	0	0	0
0830	103	0	47	33	0	9	2	1	2	7	2	0	0	0	0
0845	45	0	25	11	0	1	1	0	3	3	0	0	0	1	0
0900	170	0	80	53	1	11	6	0	3	13	3	0	0	0	0
0915	89	1	36	27	0	11	1	1	9	2	0	0	0	1	0
0930	105	1	46	44	0	7	5	0	2	0	0	0	0	0	0
0945	120	1	60	33	0	8	2	1	8	7	0	0	0	0	0
1000	93	1	48	30	0	5	1	0	1	3	2	0	0	2	0
1015	108	0	50	40	0	8	2	1	4	3	0	0	0	0	0
1030	95	1	41	27	0	10	4	0	4	8	0	0	0	0	0
1045	144	0	69	53	0	7	3	0	5	7	0	0	0	0	0
1100	110	1	46	41	0	7	3	0	3	9	0	0	0	0	0
1115	92	1	40	30	0	7	3	1	5	5	0	0	0	0	0
1130	131	0	58	48	0	8	0	0	4	10	3	0	0	0	0
1145	122	3	61	35	0	6	2	0	5	9	1	0	0	0	0
1200	132	4	61	43	0	9	0	0	7	4	4	0	0	0	0
1215	144	1	79	45	0	6	1	0	5	7	0	0	0	0	0

1230	152	7	84	38	2	4	7	0	5	4	1	0	0	0	0
1245	104	1	52	28	0	9	1	1	3	6	2	0	0	1	0
1300	140	2	83	36	0	8	2	0	6	2	1	0	0	0	0
1315	106	0	53	38	0	2	2	0	3	8	0	0	0	0	0
1330	140	2	81	35	0	10	2	1	4	5	0	0	0	0	0
1345	124	1	61	41	1	6	1	0	4	7	2	0	0	0	0
1400	165	2	99	39	2	8	2	1	5	5	2	0	0	0	0
1415	166	6	95	49	0	6	3	0	5	2	0	0	0	0	0
1430	179	0	106	51	1	10	2	2	2	3	2	0	0	0	0
1445	192	3	115	56	0	9	0	1	6	2	0	0	0	0	0
1500	206	2	102	81	0	10	3	0	6	2	0	0	0	0	0
1515	243	4	132	84	0	11	4	0	5	3	0	0	0	0	0
1530	254	7	136	94	0	9	2	0	2	4	0	0	0	0	0
1545	352	8	209	118	2	6	1	0	4	4	0	0	0	0	0
1600	359	6	217	116	1	14	1	0	2	2	0	0	0	0	0
1615	350	7	225	95	0	9	2	3	5	4	0	0	0	0	0
1630	390	8	249	117	0	9	0	0	4	2	0	0	0	1	0
1645	382	7	247	113	0	9	2	0	3	0	1	0	0	0	0
1700	460	7	313	123	0	11	1	0	4	1	0	0	0	0	0
1715	470	11	326	120	0	8	1	0	4	0	0	0	0	0	0
1730	467	7	314	130	0	8	2	0	6	0	0	0	0	0	0
1745	388	1	278	97	0	9	0	0	2	1	0	0	0	0	0
1800	373	2	268	83	1	12	2	0	3	2	0	0	0	0	0
1815	315	3	225	75	0	5	1	0	3	3	0	0	0	0	0
1830	314	2	225	75	0	7	0	0	3	2	0	0	0	0	0
1845	247	2	158	75	0	6	0	0	4	2	0	0	0	0	0
1900	213	2	140	62	0	4	0	1	3	1	0	0	0	0	0
1915	200	3	139	48	0	6	0	0	2	2	0	0	0	0	0
1930	139	1	97	40	0	1	0	0	0	0	0	0	0	0	0
1945	117	2	83	30	0	1	1	0	0	0	0	0	0	0	0
2000	128	1	89	36	0	2	0	0	0	0	0	0	0	0	0
2015	133	1	97	31	0	1	1	1	0	1	0	0	0	0	0
2030	108	2	79	24	0	2	0	1	0	0	0	0	0	0	0
2045	119	0	93	23	0	3	0	0	0	0	0	0	0	0	0
2100	79	4	53	20	0	1	0	1	0	0	0	0	0	0	0
2115	119	1	91	24	1	0	0	1	0	0	0	1	0	0	0
2130	69	1	49	16	0	1	0	0	0	1	0	1	0	0	0
2145	80	1	55	18	0	1	0	2	1	2	0	0	0	0	0
2200	76	0	58	17	0	0	0	1	0	0	0	0	0	0	0
2215	84	5	60	19	0	0	0	0	0	0	0	0	0	0	0
2230	99	6	64	26	0	2	0	0	0	1	0	0	0	0	0
2245	72	0	54	14	0	1	2	0	0	1	0	0	0	0	0
2300	58	0	46	11	0	1	0	0	0	0	0	0	0	0	0
2315	48	0	30	17	0	0	0	0	0	1	0	0	0	0	0
2330	54	1	36	16	0	0	0	0	0	1	0	0	0	0	0
2345	43	1	29	12	0	1	0	0	0	0	0	0	0	0	0
<b>00-00</b>	<b>12455</b>	<b>174</b>	<b>7514</b>	<b>3589</b>	<b>17</b>	<b>433</b>	<b>136</b>	<b>26</b>	<b>221</b>	<b>299</b>	<b>33</b>	<b>4</b>	<b>1</b>	<b>8</b>	<b>0</b>

**\* Grand Total**

<b>Time</b>	<b>Total</b>	<b>Cls</b>	<b>Cls</b>	<b>Cls</b>	<b>Cls</b>	<b>Cls</b>	<b>Cls</b>	<b>Cls</b>	<b>Cls</b>	<b>Cls</b>	<b>Cls</b>	<b>Cls</b>	<b>Cls</b>	<b>Cls</b>	<b>Cls</b>
--		<b>1</b>	<b>2</b>	<b>3</b>	<b>4</b>	<b>5</b>	<b>6</b>	<b>7</b>	<b>8</b>	<b>9</b>	<b>10</b>	<b>11</b>	<b>12</b>	<b>13</b>	<b>14</b>
--	<b>37389</b>	<b>439</b>	<b>22672</b>	<b>10646</b>	<b>47</b>	<b>1347</b>	<b>434</b>	<b>132</b>	<b>624</b>	<b>924</b>	<b>96</b>	<b>7</b>	<b>4</b>	<b>17</b>	<b>0</b>

## Traffic Count Data

Finance Number:  
 Location Code:                   1  
 Count Location       US 41 Between Madison Avenue and Causeway Boulevard

TYPE OF COUNT:       72 Hour Class Classification Count

TIME OF COUNT:

Start Date:	1/8/2013	Start Time:	Midnight
End Date:	1/10/2013	End Time:	Midnight

VOLUMES:

	Average Daily:	34,659	Peak Hour Start Time:	5:00 PM
	Daily Truck Average:	3,651	Average Peak Hour:	3,168
			Max Hour Truck Average:	307
			Peak Hour Truck Average:	154

TRAVEL CHARACTERISTICS:

K MEASURED

D MEASURED

	K=	9%		D=	71%
	T Max Hour	19%		T Daily	11%
	T med (max)	4%		T med Daily	3%
	T heavy (max)	15%		T heavy Daily	8%
	T peak Hour	5%			
	T med Peak Hour	2%		Axle Factor	0.92
	T heavy Peak Hour	3%			

## Southern Traffic Services, Inc. Class Speed Matrix

**US 41 between CR 676A (Madison Ave) & CR 676 (Causeway Blvd) Northbound 27.91473 , -82.40190**

**Datasets:**

**Site:** [15nbfast] !C7049  
**Site:** [15nbmid] !C7049  
**Site:** [15nbslow] !C6543  
**Direction:** 1 - North bound, A hit first., Lane: 1  
**Survey Duration:** 8:00 Monday, January 28, 2013 => 11:47 Friday, February 01, 2013  
**File:** G:\DATA\2013\Private\13015\diego0128\13015\UM15nbslow.eco (Plus)  
**Identifier:** T583MW10 MC56-L5 [MC55] (c)Microcom 19Oct04  
**Algorithm:** Factory default  
**Data type:** Axle sensors - Paired (Class, Speed, Count)

**Profile:**

**Filter time:** 0:00 Tuesday, January 29, 2013 => 0:00 Friday, February 01, 2013  
**Included classes:** 1, 2, 3, 4, 5, 6, 7, 8, 9, 10, 11, 12, 13, 14  
**Speed range:** 0 - 100 mph.  
**Direction:** North (bound)

**Speed (mph)**

**Speed Totals**

	Class															
	1	2	3	4	5	6	7	8	9	10	11	12	13	14		
0 - 5	10	4	1	.	.	.	1	.	.	.	.	.	.	.	16	0.0%
5 - 10	11	80	8	.	1	5	1	.	.	.	.	.	.	.	106	0.2%
10 - 15	33	175	32	.	4	4	.	.	.	.	.	.	.	.	248	0.5%
15 - 20	23	232	50	.	11	12	.	1	7	.	.	.	.	.	336	0.7%
20 - 25	15	312	101	.	23	13	.	4	9	2	.	.	.	.	479	1.0%
25 - 30	21	351	158	1	40	26	3	23	40	1	.	.	.	.	664	1.3%
30 - 35	13	568	188	2	41	51	8	32	90	6	.	.	2	.	1001	2.0%
35 - 40	24	1286	510	1	109	90	20	77	217	20	.	.	3	.	2357	4.7%
40 - 45	39	3497	1206	7	268	194	42	199	422	26	1	.	9	.	5910	11.8%
45 - 50	65	7746	2914	14	416	282	49	241	480	28	.	.	11	.	12246	24.4%
50 - 55	69	10060	3484	8	410	231	41	142	319	17	.	.	5	.	14786	29.4%
55 - 60	62	6025	1896	4	149	117	9	53	88	2	.	.	.	.	8405	16.7%
60 - 65	36	1994	669	.	46	38	.	10	12	1	.	.	.	.	2806	5.6%
65 - 70	18	522	137	.	16	13	.	.	1	.	.	.	.	.	707	1.4%
70 - 75	4	96	29	.	3	5	.	.	.	.	.	.	.	.	137	0.3%
75 - 80	3	34	12	.	.	.	.	.	.	.	.	.	.	.	49	0.1%
80 - 85	2	6	2	.	.	1	.	.	.	.	.	.	.	.	11	0.0%
85 - 90	1	7	.	.	.	.	.	.	.	.	.	.	.	.	8	0.0%
90 - 95	.	4	.	.	.	.	.	.	.	.	.	.	.	.	4	0.0%
95 - 100	.	1	.	.	.	.	.	.	.	.	.	.	.	.	1	0.0%
	<b>449</b>	<b>33000</b>	<b>11397</b>	<b>37</b>	<b>1537</b>	<b>1082</b>	<b>174</b>	<b>782</b>	<b>1685</b>	<b>103</b>	<b>1</b>	<b>0</b>	<b>30</b>	<b>0</b>	<b>50277</b>	
	<b>0.9%</b>	<b>65.6%</b>	<b>22.7%</b>	<b>0.1%</b>	<b>3.1%</b>	<b>2.2%</b>	<b>0.3%</b>	<b>1.6%</b>	<b>3.4%</b>	<b>0.2%</b>	<b>0.0%</b>	<b>0.0%</b>	<b>0.1%</b>	<b>0.0%</b>		

# Southern Traffic Services, Inc.

## Vehicle Counts

**US 41 between CR 676A (Madison Ave) & CR 676 (Causeway Blvd) Northbound 27.91473 , -82.40190**

**Datasets:**

**Site:** [15nbfast] !C7049  
**Site:** [15nbmid] !C7049  
**Site:** [15nbslow] !C6543  
**Direction:** 1 - North bound, A hit first., Lane: 1  
**Survey Duration:** 8:00 Monday, January 28, 2013 => 11:47 Friday, February 01, 2013  
**File:** G:\DATA\2013\Private\13015\diego0128\13015\UM15nbslow.eco (Plus)  
**Identifier:** T583MW10 MC56-L5 [MC55] (c)Microcom 19Oct04  
**Algorithm:** Factory default  
**Data type:** Axle sensors - Paired (Class, Speed, Count)

**Profile:**

**Filter time:** 0:00 Tuesday, January 29, 2013 => 0:00 Friday, February 01, 2013  
**Included classes:** 1, 2, 3, 4, 5, 6, 7, 8, 9, 10, 11, 12, 13, 14  
**Speed range:** 0 - 100 mph.  
**Direction:** North (bound)  
**Separation:** All - (Headway)  
**Name:** Factory default profile  
**Scheme:** Vehicle classification (FLDOT)  
**Units:** Non metric (ft, mi, ft/s, mph, lb, ton)  
**In profile:** Vehicles = 50277

**Tuesday, January 29, 2013 - Total=16547, 15 minute drops**

0000	0100	0200	0300	0400	0500	0600	0700	0800	0900	1000	1100	1200	1300	1400	1500	1600	1700	1800	1900	2000	2100	2200	2300	
60	56	62	112	250	701	1683	2176	1564	1031	882	766	796	952	873	1028	934	978	661	349	195	175	162	101	
14	20	14	13	48	102	334	489	476	302	222	201	208	287	175	243	263	294	204	126	59	54	55	30	21
13	10	21	25	56	170	427	450	412	234	230	168	212	211	174	247	216	243	190	90	35	38	36	29	14
21	11	13	29	60	185	454	642	307	244	234	185	208	232	258	298	236	210	123	64	50	46	37	20	12
12	15	14	45	86	244	468	595	369	251	196	212	168	222	266	240	219	231	144	69	51	37	34	22	12

AM Peak 0700 - 0800 (2176), AM PHF=0.85 PM Peak 1445 - 1545 (1054), PM PHF=0.88

**Wednesday, January 30, 2013 - Total=16298, 15 minute drops**

0000	0100	0200	0300	0400	0500	0600	0700	0800	0900	1000	1100	1200	1300	1400	1500	1600	1700	1800	1900	2000	2100	2200	2300	
59	65	44	98	259	663	1609	2026	1624	950	888	882	802	901	897	1007	875	905	610	337	246	258	192	101	
21	13	8	23	54	104	330	512	577	281	240	194	206	245	231	258	260	250	171	120	65	91	52	32	22
14	19	13	18	47	131	355	380	386	267	171	238	203	258	232	229	211	245	158	80	63	49	51	25	12
12	19	11	30	66	208	450	489	379	223	263	236	207	189	248	277	201	234	135	86	64	63	50	35	12
12	14	12	27	92	220	474	645	282	179	214	214	186	209	186	243	203	176	146	51	54	55	39	9	20

AM Peak 0730 - 0830 (2097), AM PHF=0.81 PM Peak 1515 - 1615 (1009), PM PHF=0.91

**Thursday, January 31, 2013 - Total=17432, 15 minute drops**

0000	0100	0200	0300	0400	0500	0600	0700	0800	0900	1000	1100	1200	1300	1400	1500	1600	1700	1800	1900	2000	2100	2200	2300	
66	46	65	115	263	704	1445	2297	1545	1054	816	883	898	751	980	1476	1444	828	603	347	240	207	190	169	
22	15	19	17	40	119	322	592	468	272	194	213	255	229	320	358	483	215	176	86	82	50	50	69	20
12	9	22	29	59	145	421	562	414	250	206	254	228	224	242	368	521	236	179	117	49	62	59	38	31
12	15	7	35	74	225	162	552	364	270	196	216	213	205	168	388	219	188	135	79	58	45	39	37	11
20	7	17	34	90	215	540	591	299	262	220	200	202	93	250	362	221	189	113	65	51	50	42	25	16

AM Peak 0700 - 0800 (2297), AM PHF=0.97 PM Peak 1530 - 1630 (1754), PM PHF=0.84

# Southern Traffic Services, Inc.

## Classification Count

**US 41 between CR 676A (Madison Ave) & CR 676 (Causeway Blvd) Northbound 27.91473 , -82.40190**

**Datasets:**

**Site:** [15nbfast] !C7049  
**Site:** [15nbmid] !C7049  
**Site:** [15nbslow] !C6543  
**Direction:** 1 - North bound, A hit first., **Lane:** 1  
**Survey Duration:** 8:00 Monday, January 28, 2013 => 11:47 Friday, February 01, 2013  
**File:** G:\DATA\2013\Private\13015\diego0128\13015\UM15nbslow.eco (Plus)  
**Identifier:** T583MW10 MC56-L5 [MC55] (c)Microcom 19Oct04  
**Algorithm:** Factory default  
**Data type:** Axle sensors - Paired (Class, Speed, Count)

**Profile:**

**Filter time:** 0:00 Tuesday, January 29, 2013 => 0:00 Friday, February 01, 2013  
**Included classes:** 1, 2, 3, 4, 5, 6, 7, 8, 9, 10, 11, 12, 13, 14  
**Speed range:** 0 - 100 mph.  
**Direction:** North (bound)

**Tuesday, January 29, 2013**

Time	Total	Cls 1	Cls 2	Cls 3	Cls 4	Cls 5	Cls 6	Cls 7	Cls 8	Cls 9	Cls 10	Cls 11	Cls 12	Cls 13	Cls 14
0000	14	0	13	0	0	0	0	0	0	1	0	0	0	0	0
0015	13	0	7	3	0	2	0	0	0	1	0	0	0	0	0
0030	21	0	18	2	0	0	0	0	0	1	0	0	0	0	0
0045	12	1	7	2	0	0	1	0	0	1	0	0	0	0	0
0100	20	1	16	1	0	0	0	0	0	2	0	0	0	0	0
0115	10	0	8	2	0	0	0	0	0	0	0	0	0	0	0
0130	11	0	10	1	0	0	0	0	0	0	0	0	0	0	0
0145	15	0	6	6	0	2	0	0	0	1	0	0	0	0	0
0200	14	0	4	4	0	0	2	0	0	4	0	0	0	0	0
0215	21	0	14	3	0	0	0	0	1	3	0	0	0	0	0
0230	13	0	7	4	0	0	0	0	1	1	0	0	0	0	0
0245	14	0	12	2	0	0	0	0	0	0	0	0	0	0	0
0300	13	0	7	5	0	1	0	0	0	0	0	0	0	0	0
0315	25	0	17	3	0	2	0	0	0	3	0	0	0	0	0
0330	29	0	20	3	0	0	1	0	0	5	0	0	0	0	0
0345	45	2	27	9	0	1	0	0	1	5	0	0	0	0	0
0400	48	0	31	7	0	0	2	0	3	5	0	0	0	0	0
0415	56	0	25	20	0	1	1	0	3	6	0	0	0	0	0
0430	60	0	41	11	0	1	1	0	2	4	0	0	0	0	0
0445	86	3	50	24	0	1	1	0	2	5	0	0	0	0	0
0500	103	2	67	23	0	2	4	0	2	3	0	0	0	0	0
0515	169	5	94	50	0	5	1	0	5	8	1	0	0	0	0
0530	185	1	127	43	0	5	2	0	3	4	0	0	0	0	0
0545	244	7	154	67	0	7	1	0	2	3	3	0	0	0	0
0600	334	8	227	78	0	5	5	0	1	9	1	0	0	0	0
0615	427	5	308	97	1	5	4	0	2	4	1	0	0	0	0
0630	454	4	333	89	0	7	7	1	2	10	1	0	0	0	0
0645	470	5	338	93	0	13	1	3	4	11	1	0	0	1	0
0700	487	6	348	95	0	11	12	0	5	10	0	0	0	0	0
0715	450	2	344	77	0	5	1	2	6	11	2	0	0	0	0
0730	642	6	488	109	0	13	2	0	8	12	3	0	0	1	0
0745	595	4	450	110	0	10	10	0	2	8	0	0	0	1	0
0800	477	2	362	79	1	9	10	0	7	7	0	0	0	0	0
0815	411	2	295	82	0	7	9	1	7	8	0	0	0	0	0
0830	308	2	221	52	0	11	5	2	8	4	3	0	0	0	0
0845	368	2	248	76	1	17	6	3	9	6	0	0	0	0	0
0900	303	4	192	67	0	10	11	0	10	8	1	0	0	0	0
0915	233	1	140	51	0	10	14	4	3	9	1	0	0	0	0
0930	244	0	143	57	0	12	11	4	7	10	0	0	0	0	0
0945	251	2	136	60	0	14	10	2	7	18	2	0	0	0	0



1000	222	2	106	61	0	12	11	1	9	19	0	0	0	1	0
1015	230	2	111	74	1	9	17	2	7	7	0	0	0	0	0
1030	235	1	152	44	0	9	7	4	4	12	2	0	0	0	0
1045	196	0	100	53	0	12	9	2	3	16	1	0	0	0	0
1100	200	2	114	52	0	7	8	3	4	10	0	0	0	0	0
1115	168	2	82	45	1	11	8	3	4	12	0	0	0	0	0
1130	185	1	106	47	0	10	9	2	6	4	0	0	0	0	0
1145	213	1	112	63	0	11	8	2	4	11	1	0	0	0	0
1200	207	4	111	57	0	6	8	7	6	8	0	0	0	0	0
1215	212	0	127	55	0	6	4	1	8	9	1	0	0	1	0
1230	208	5	107	49	0	10	7	0	9	20	1	0	0	0	0
1245	168	6	95	43	0	7	7	2	4	3	1	0	0	0	0
1300	287	7	178	57	0	14	15	0	5	11	0	0	0	0	0
1315	211	1	116	52	0	14	8	3	8	8	0	0	0	1	0
1330	232	2	118	74	1	12	10	4	7	4	0	0	0	0	0
1345	223	3	122	59	0	14	7	2	5	10	1	0	0	0	0
1400	174	4	96	40	0	7	11	1	4	11	0	0	0	0	0
1415	174	3	104	48	0	5	5	1	2	6	0	0	0	0	0
1430	258	3	144	71	0	8	6	3	6	15	1	0	0	1	0
1445	266	4	151	66	0	10	12	3	7	13	0	0	0	0	0
1500	243	4	138	64	1	8	6	0	10	11	1	0	0	0	0
1515	248	4	146	67	1	8	10	0	4	7	0	0	0	1	0
1530	297	1	182	80	0	15	8	0	1	10	0	0	0	0	0
1545	240	0	134	78	1	5	7	0	4	11	0	0	0	0	0
1600	263	8	160	62	0	10	4	0	8	9	1	0	0	1	0
1615	216	6	123	53	1	7	8	0	3	13	2	0	0	0	0
1630	236	2	163	51	0	8	6	0	4	2	0	0	0	0	0
1645	219	1	141	59	0	4	2	0	2	9	1	0	0	0	0
1700	295	2	189	86	0	8	2	0	3	4	1	0	0	0	0
1715	242	7	162	56	0	7	3	0	3	4	0	0	0	0	0
1730	210	0	145	46	0	6	4	0	4	4	1	0	0	0	0
1745	231	1	162	41	0	12	5	0	3	7	0	0	0	0	0
1800	204	2	133	56	0	6	1	0	2	4	0	0	0	0	0
1815	190	1	135	45	0	3	0	0	0	6	0	0	0	0	0
1830	123	3	79	36	0	1	0	0	2	2	0	0	0	0	0
1845	144	2	98	35	0	4	0	0	4	1	0	0	0	0	0
1900	126	0	95	24	0	4	1	0	0	2	0	0	0	0	0
1915	90	1	56	20	0	5	2	0	1	5	0	0	0	0	0
1930	64	1	37	20	0	1	0	0	1	3	0	0	0	1	0
1945	69	0	45	18	0	1	0	0	2	3	0	0	0	0	0
2000	59	2	39	15	0	1	0	0	1	1	0	0	0	0	0
2015	35	0	22	12	0	0	0	0	0	1	0	0	0	0	0
2030	50	0	34	13	0	1	0	0	0	2	0	0	0	0	0
2045	51	1	40	7	0	0	2	0	0	1	0	0	0	0	0
2100	54	1	43	7	0	0	1	0	0	2	0	0	0	0	0
2115	38	0	27	8	0	0	1	0	0	2	0	0	0	0	0
2130	46	0	39	5	0	0	0	0	0	2	0	0	0	0	0
2145	37	0	27	7	0	1	0	0	1	1	0	0	0	0	0
2200	55	1	38	8	0	3	4	0	0	1	0	0	0	0	0
2215	36	0	27	7	0	0	0	0	0	2	0	0	0	0	0
2230	37	0	26	7	0	3	0	0	0	1	0	0	0	0	0
2245	34	0	28	6	0	0	0	0	0	0	0	0	0	0	0
2300	30	1	17	12	0	0	0	0	0	0	0	0	0	0	0
2315	29	0	24	4	0	1	0	0	0	0	0	0	0	0	0
2330	20	0	15	2	0	1	0	0	0	2	0	0	0	0	0
2345	22	0	17	3	0	1	0	0	0	1	0	0	0	0	0
<b>00-00</b>	<b>16547</b>	<b>182</b>	<b>10693</b>	<b>3797</b>	<b>10</b>	<b>518</b>	<b>389</b>	<b>68</b>	<b>288</b>	<b>556</b>	<b>36</b>	<b>0</b>	<b>0</b>	<b>10</b>	<b>0</b>

**Wednesday, January 30, 2013**

Time	Total	Cls		Cls		Cls		Cls		Cls		Cls		Cls	
		1	2	3	4	5	6	7	8	9	10	11	12	13	14
0000	21	0	16	3	0	0	0	0	0	2	0	0	0	0	0
0015	14	1	7	4	0	0	1	0	0	1	0	0	0	0	0
0030	12	0	8	2	0	0	0	0	0	2	0	0	0	0	0
0045	12	0	9	2	0	0	0	0	0	1	0	0	0	0	0
0100	13	1	9	2	0	0	0	0	0	1	0	0	0	0	0
0115	19	0	13	4	0	0	2	0	0	0	0	0	0	0	0
0130	19	0	13	2	0	0	1	0	0	3	0	0	0	0	0
0145	14	0	11	3	0	0	0	0	0	0	0	0	0	0	0
0200	8	0	6	1	0	0	0	0	0	1	0	0	0	0	0

0215	13	0	8	5	0	0	0	0	0	0	0	0	0	0
0230	11	0	5	4	0	0	1	0	0	1	0	0	0	0
0245	12	0	7	3	0	0	0	0	0	2	0	0	0	0
0300	23	1	11	7	0	0	2	0	0	1	1	0	0	0
0315	18	0	14	1	0	1	0	0	1	1	0	0	0	0
0330	30	0	19	4	0	1	0	0	0	6	0	0	0	0
0345	27	0	17	3	0	1	0	0	1	5	0	0	0	0
0400	54	2	31	11	0	0	1	0	2	7	0	0	0	0
0415	47	0	33	11	0	0	0	0	0	2	1	0	0	0
0430	66	0	33	16	0	0	1	0	5	11	0	0	0	0
0445	92	2	58	21	0	0	1	0	3	7	0	0	0	0
0500	104	2	66	27	0	0	1	0	1	7	0	0	0	0
0515	131	2	82	32	0	2	2	0	3	7	1	0	0	0
0530	211	0	140	50	2	4	3	1	2	9	0	0	0	0
0545	217	3	143	56	0	5	2	0	2	6	0	0	0	0
0600	331	2	233	72	0	5	9	0	2	7	0	0	0	1
0615	354	7	225	103	1	5	4	0	4	5	0	0	0	0
0630	450	5	320	95	1	14	2	3	1	9	0	0	0	0
0645	474	6	344	100	0	7	4	0	2	9	2	0	0	0
0700	512	2	372	106	0	16	4	0	5	6	0	0	0	1
0715	380	3	276	72	1	4	10	0	4	9	1	0	0	0
0730	490	4	385	75	0	9	4	0	4	7	2	0	0	0
0745	645	6	491	115	1	10	2	3	5	11	1	0	0	0
0800	576	8	431	112	0	4	9	0	4	7	0	0	0	1
0815	388	3	280	67	1	12	6	0	3	15	1	0	0	0
0830	377	1	265	75	0	8	12	3	2	10	0	0	0	1
0845	283	2	178	72	0	8	7	2	4	9	1	0	0	0
0900	280	3	176	67	0	11	5	2	6	8	1	0	0	1
0915	267	4	150	71	0	16	8	2	4	10	2	0	0	0
0930	223	1	144	50	0	4	6	0	6	11	1	0	0	0
0945	179	0	113	40	1	8	5	0	3	9	0	0	0	0
1000	241	4	153	53	1	10	10	2	1	6	1	0	0	0
1015	170	1	86	43	0	7	12	3	9	7	2	0	0	0
1030	263	1	151	73	0	9	9	1	9	10	0	0	0	0
1045	214	2	113	62	0	8	7	0	10	12	0	0	0	0
1100	194	1	112	43	0	9	6	5	6	10	1	0	0	1
1115	239	2	136	55	0	15	7	1	5	16	1	0	0	1
1130	236	1	137	62	0	5	9	1	7	13	1	0	0	0
1145	214	4	117	52	0	9	11	4	6	11	0	0	0	0
1200	205	2	113	55	0	6	11	0	4	13	1	0	0	0
1215	204	0	101	57	1	9	12	1	8	14	1	0	0	0
1230	207	3	113	53	0	8	7	1	4	17	1	0	0	0
1245	185	6	101	39	0	6	9	5	6	13	0	0	0	0
1300	245	2	125	62	0	14	15	3	7	14	2	0	0	1
1315	259	2	157	60	0	8	13	2	5	10	2	0	0	0
1330	188	3	108	53	1	5	4	0	6	6	2	0	0	0
1345	209	2	105	57	0	15	14	0	7	9	0	0	0	0
1400	232	5	137	46	1	10	10	3	4	15	0	1	0	0
1415	231	3	136	54	1	6	5	4	8	14	0	0	0	0
1430	248	3	150	64	0	17	10	0	1	3	0	0	0	0
1445	186	3	110	40	0	9	8	3	3	10	0	0	0	0
1500	258	1	161	54	0	11	11	2	2	15	0	0	0	1
1515	229	2	135	60	0	9	9	1	3	9	0	0	0	1
1530	277	3	166	78	0	9	5	0	4	10	1	0	0	1
1545	243	4	128	65	2	13	11	0	7	13	0	0	0	0
1600	260	3	136	92	1	7	5	0	6	8	1	0	0	1
1615	211	2	115	58	0	10	9	0	6	11	0	0	0	0
1630	201	3	119	55	1	7	9	0	2	5	0	0	0	0
1645	203	0	124	52	0	8	4	0	5	8	2	0	0	0
1700	252	1	174	59	0	4	3	0	4	6	1	0	0	0
1715	243	5	164	54	0	10	2	0	3	5	0	0	0	0
1730	234	1	149	55	0	11	6	0	1	10	0	0	0	1
1745	176	1	114	44	0	6	1	0	3	7	0	0	0	0
1800	171	2	116	37	0	5	6	0	3	2	0	0	0	0
1815	158	0	118	31	0	4	0	0	0	5	0	0	0	0
1830	135	1	100	24	0	3	0	0	3	3	1	0	0	0
1845	146	2	88	42	0	5	0	0	7	2	0	0	0	0
1900	120	1	86	26	0	2	1	0	2	2	0	0	0	0
1915	80	1	57	14	0	0	1	0	1	5	1	0	0	0
1930	86	0	65	16	0	1	0	0	0	4	0	0	0	0

1945	51	1	27	14	0	1	1	0	3	4	0	0	0	0	0
2000	65	1	44	18	0	0	0	0	0	2	0	0	0	0	0
2015	63	0	40	18	0	1	0	1	2	1	0	0	0	0	0
2030	64	0	37	20	0	3	0	0	3	1	0	0	0	0	0
2045	54	0	39	11	0	1	0	0	0	3	0	0	0	0	0
2100	91	0	72	17	0	0	0	0	1	1	0	0	0	0	0
2115	49	1	36	5	0	3	0	0	1	3	0	0	0	0	0
2130	63	1	43	10	0	3	0	0	3	3	0	0	0	0	0
2145	55	0	41	12	0	1	0	0	0	1	0	0	0	0	0
2200	52	0	38	11	0	3	0	0	0	0	0	0	0	0	0
2215	51	1	40	5	0	0	1	0	3	1	0	0	0	0	0
2230	50	1	34	7	0	4	1	0	0	3	0	0	0	0	0
2245	39	0	29	8	0	0	0	0	0	2	0	0	0	0	0
2300	32	0	27	4	0	0	0	0	0	1	0	0	0	0	0
2315	25	0	21	3	0	1	0	0	0	0	0	0	0	0	0
2330	35	0	23	9	0	1	0	0	0	2	0	0	0	0	0
2345	9	0	7	2	0	0	0	0	0	0	0	0	0	0	0
<b>00-00</b>	<b>16298</b>	<b>160</b>	<b>10516</b>	<b>3739</b>	<b>17</b>	<b>487</b>	<b>390</b>	<b>59</b>	<b>273</b>	<b>606</b>	<b>37</b>	<b>1</b>	<b>0</b>	<b>13</b>	<b>0</b>

**Thursday, January 31, 2013**

Time	Total	Cls 1	Cls 2	Cls 3	Cls 4	Cls 5	Cls 6	Cls 7	Cls 8	Cls 9	Cls 10	Cls 11	Cls 12	Cls 13	Cls 14
0000	22	0	18	3	0	1	0	0	0	0	0	0	0	0	0
0015	13	0	12	1	0	0	0	0	0	0	0	0	0	0	0
0030	11	0	9	1	0	0	1	0	0	0	0	0	0	0	0
0045	20	0	16	2	0	1	0	0	0	1	0	0	0	0	0
0100	15	0	6	3	0	1	0	0	0	5	0	0	0	0	0
0115	9	0	6	1	0	0	0	0	1	1	0	0	0	0	0
0130	15	0	11	3	0	0	0	0	0	1	0	0	0	0	0
0145	7	0	4	2	0	0	0	0	0	1	0	0	0	0	0
0200	19	2	14	2	0	0	1	0	0	0	0	0	0	0	0
0215	22	0	16	2	0	0	1	0	0	3	0	0	0	0	0
0230	7	0	3	2	0	0	0	0	0	2	0	0	0	0	0
0245	17	0	11	4	0	1	0	0	0	1	0	0	0	0	0
0300	17	0	9	3	0	0	0	0	0	5	0	0	0	0	0
0315	29	0	16	3	0	1	2	0	0	7	0	0	0	0	0
0330	35	0	19	5	0	2	0	0	2	7	0	0	0	0	0
0345	34	1	19	10	0	1	0	0	0	3	0	0	0	0	0
0400	40	0	27	7	0	0	1	0	1	4	0	0	0	0	0
0415	59	0	39	11	0	1	2	0	3	3	0	0	0	0	0
0430	74	0	46	17	0	1	2	0	1	6	1	0	0	0	0
0445	90	1	63	16	0	1	1	0	2	5	1	0	0	0	0
0500	119	0	78	23	0	4	3	0	2	6	1	0	0	2	0
0515	145	0	100	29	0	4	3	0	4	5	0	0	0	0	0
0530	225	0	150	57	0	4	3	0	3	7	1	0	0	0	0
0545	215	0	133	65	0	5	4	0	1	7	0	0	0	0	0
0600	323	2	235	65	2	6	5	0	3	4	1	0	0	0	0
0615	420	4	281	105	2	11	3	0	4	10	0	0	0	0	0
0630	162	1	96	47	0	8	3	0	0	7	0	0	0	0	0
0645	540	1	396	118	0	10	2	0	1	11	1	0	0	0	0
0700	593	1	421	133	0	12	6	1	6	10	3	0	0	0	0
0715	562	1	442	91	0	10	6	0	4	7	1	0	0	0	0
0730	551	3	413	105	0	15	2	0	6	7	0	0	0	0	0
0745	592	6	484	86	0	2	4	4	0	5	1	0	0	0	0
0800	468	5	360	77	0	9	6	1	1	8	0	0	0	1	0
0815	413	1	311	80	0	6	3	1	2	9	0	0	0	0	0
0830	364	1	252	67	0	12	14	0	6	11	1	0	0	0	0
0845	301	7	226	47	0	7	12	0	1	1	0	0	0	0	0
0900	271	1	187	51	0	9	8	0	4	10	1	0	0	0	0
0915	249	1	166	51	0	5	7	1	4	14	0	0	0	0	0
0930	270	3	149	82	0	19	7	0	2	7	1	0	0	0	0
0945	262	0	160	65	0	5	13	2	7	9	1	0	0	0	0
1000	194	1	113	54	0	8	3	1	1	11	2	0	0	0	0
1015	206	1	124	47	0	10	5	2	6	11	0	0	0	0	0
1030	196	0	112	60	0	8	3	2	6	4	1	0	0	0	0
1045	220	3	132	51	0	6	8	2	3	14	1	0	0	0	0
1100	213	1	122	52	0	13	2	1	9	13	0	0	0	0	0
1115	254	1	157	58	0	11	7	5	5	9	1	0	0	0	0
1130	216	1	135	50	1	10	5	1	5	7	1	0	0	0	0
1145	200	0	116	57	0	11	4	0	2	10	0	0	0	0	0

1200	255	1	153	59	0	13	4	1	7	14	3	0	0	0	0
1215	228	3	123	65	0	11	5	1	7	11	2	0	0	0	0
1230	213	1	129	62	0	8	5	3	0	4	1	0	0	0	0
1245	202	0	108	61	0	14	4	1	2	10	1	0	0	1	0
1300	229	0	142	52	0	11	9	2	4	9	0	0	0	0	0
1315	224	1	134	51	0	14	4	0	7	13	0	0	0	0	0
1330	206	0	109	62	0	7	8	3	6	11	0	0	0	0	0
1345	92	2	63	15	0	3	3	1	3	2	0	0	0	0	0
1400	320	7	223	60	0	12	6	0	5	7	0	0	0	0	0
1415	242	1	142	58	0	14	4	5	7	11	0	0	0	0	0
1430	168	3	97	40	0	7	7	2	2	10	0	0	0	0	0
1445	250	4	148	67	0	9	8	0	4	9	0	0	0	1	0
1500	358	5	234	76	2	17	6	0	5	10	2	0	0	1	0
1515	369	1	249	86	1	13	6	1	8	4	0	0	0	0	0
1530	387	4	280	81	0	10	2	0	4	6	0	0	0	0	0
1545	362	4	257	81	0	5	5	0	3	6	0	0	0	1	0
1600	484	4	330	122	1	11	5	0	1	10	0	0	0	0	0
1615	522	2	372	108	0	18	11	0	2	9	0	0	0	0	0
1630	217	4	131	61	0	6	7	1	1	6	0	0	0	0	0
1645	221	1	141	56	0	9	2	0	5	7	0	0	0	0	0
1700	216	0	147	45	0	9	6	0	2	7	0	0	0	0	0
1715	235	2	179	37	0	6	3	0	1	7	0	0	0	0	0
1730	189	2	135	36	0	2	5	0	4	5	0	0	0	0	0
1745	188	1	122	50	0	8	5	0	2	0	0	0	0	0	0
1800	176	0	125	40	0	4	0	0	2	5	0	0	0	0	0
1815	179	0	126	35	0	6	3	1	3	5	0	0	0	0	0
1830	135	1	85	41	0	2	1	0	4	1	0	0	0	0	0
1845	113	0	85	20	1	3	1	1	0	2	0	0	0	0	0
1900	86	1	62	20	0	1	1	0	0	1	0	0	0	0	0
1915	117	1	76	34	0	1	1	0	0	4	0	0	0	0	0
1930	79	0	60	12	0	0	0	0	1	6	0	0	0	0	0
1945	65	0	44	16	0	3	1	0	1	0	0	0	0	0	0
2000	82	0	54	22	0	1	1	0	2	2	0	0	0	0	0
2015	49	0	39	4	0	1	2	0	0	3	0	0	0	0	0
2030	58	0	41	11	0	3	0	0	1	2	0	0	0	0	0
2045	52	1	36	12	0	1	0	0	0	2	0	0	0	0	0
2100	49	0	42	4	0	1	0	0	2	0	0	0	0	0	0
2115	62	0	45	12	0	1	0	0	0	4	0	0	0	0	0
2130	45	0	35	8	0	1	0	0	0	1	0	0	0	0	0
2145	50	0	37	12	0	0	0	0	0	1	0	0	0	0	0
2200	50	0	36	11	0	2	0	0	0	1	0	0	0	0	0
2215	59	0	40	18	0	0	0	0	0	1	0	0	0	0	0
2230	39	0	27	7	0	3	0	0	1	1	0	0	0	0	0
2245	42	0	26	11	0	2	0	0	2	1	0	0	0	0	0
2300	69	0	45	18	0	5	0	0	0	1	0	0	0	0	0
2315	38	0	21	13	0	2	0	0	1	1	0	0	0	0	0
2330	37	0	24	12	0	0	0	0	1	0	0	0	0	0	0
2345	25	0	17	6	0	1	0	0	0	1	0	0	0	0	0
<b>00-00</b>	<b>17432</b>	<b>107</b>	<b>11791</b>	<b>3861</b>	<b>10</b>	<b>532</b>	<b>303</b>	<b>47</b>	<b>221</b>	<b>523</b>	<b>30</b>	<b>0</b>	<b>0</b>	<b>7</b>	<b>0</b>

**Grand Total**

<b>Time</b>	<b>Total</b>	<b>Cls</b>	<b>Cls</b>	<b>Cls</b>	<b>Cls</b>	<b>Cls</b>	<b>Cls</b>	<b>Cls</b>	<b>Cls</b>	<b>Cls</b>	<b>Cls</b>	<b>Cls</b>	<b>Cls</b>	<b>Cls</b>	<b>Cls</b>
		<b>1</b>	<b>2</b>	<b>3</b>	<b>4</b>	<b>5</b>	<b>6</b>	<b>7</b>	<b>8</b>	<b>9</b>	<b>10</b>	<b>11</b>	<b>12</b>	<b>13</b>	<b>14</b>
--	50277	449	33000	11397	37	1537	1082	174	782	1685	103	1	0	30	0

## Southern Traffic Services, Inc. Class Speed Matrix

**US 41 between CR 676A (Madison Ave) & CR 676 (Causeway Blvd) Southbound 27.91473 , -82.40190**

**Datasets:**

**Site:** [15sbfast] !4429  
**Site:** [15sbmid] !4429  
**Site:** [15sbslow] !9031  
**Direction:** 3 - South bound, A hit first., Lane: 1  
**Survey Duration:** 8:00 Monday, January 28, 2013 => 11:45 Friday, February 01, 2013  
**File:** G:\DATA\2013\Private\13015\diego0128\13015\UM15sbslow.eco (Plus)  
**Identifier:** AR32XKW4 MC56-L5 [MC55] (c)Microcom 19Oct04  
**Algorithm:** Factory default  
**Data type:** Axle sensors - Paired (Class, Speed, Count)

**Profile:**

**Filter time:** 0:00 Tuesday, January 29, 2013 => 0:00 Friday, February 01, 2013  
**Included classes:** 1, 2, 3, 4, 5, 6, 7, 8, 9, 10, 11, 12, 13, 14  
**Speed range:** 0 - 100 mph.  
**Direction:** South (bound)

**Speed (mph)**

**Speed Totals**

	Class															
	1	2	3	4	5	6	7	8	9	10	11	12	13	14		
0 - 5	.	3	4	1	.	.	.	.	.	.	.	.	.	.	8	0.0%
5 - 10	14	65	15	3	2	1	.	.	.	.	.	.	.	.	100	0.2%
10 - 15	34	103	18	.	4	7	.	.	4	.	.	.	.	.	170	0.3%
15 - 20	16	58	24	.	1	13	1	.	7	.	.	.	.	.	120	0.2%
20 - 25	11	99	32	.	8	16	.	9	8	.	.	.	1	.	184	0.3%
25 - 30	7	194	66	.	15	7	3	13	15	2	.	.	1	.	323	0.6%
30 - 35	7	418	186	.	48	32	7	45	57	6	.	.	1	.	807	1.5%
35 - 40	18	1131	392	6	118	94	25	77	210	8	.	1	7	.	2087	3.9%
40 - 45	24	3366	1141	6	258	196	73	188	425	31	.	.	9	.	5717	10.6%
45 - 50	58	8781	2626	6	398	235	132	300	511	34	1	.	22	.	13104	24.4%
50 - 55	93	12658	3512	1	368	201	64	228	357	15	2	.	11	.	17510	32.6%
55 - 60	98	7375	2057	2	134	85	5	62	141	6	.	.	5	.	9970	18.6%
60 - 65	45	2122	548	.	40	31	.	8	28	2	.	.	.	.	2824	5.3%
65 - 70	21	455	125	.	8	2	.	.	.	.	.	.	.	.	611	1.1%
70 - 75	9	76	32	.	3	.	.	1	.	.	.	.	.	.	121	0.2%
75 - 80	3	11	4	.	1	.	.	.	.	.	.	.	.	.	19	0.0%
80 - 85	1	11	2	.	.	.	.	.	.	.	.	.	.	.	14	0.0%
85 - 90	1	8	.	.	1	.	.	.	.	.	.	.	.	.	10	0.0%
90 - 95	1	.	.	.	.	.	.	.	.	.	.	.	.	.	1	0.0%
95 - 100	.	1	.	.	.	.	.	.	.	.	.	.	.	.	1	0.0%
	<b>461</b>	<b>36935</b>	<b>10784</b>	<b>25</b>	<b>1407</b>	<b>920</b>	<b>310</b>	<b>931</b>	<b>1763</b>	<b>104</b>	<b>3</b>	<b>1</b>	<b>57</b>	<b>0</b>	<b>53701</b>	
	<b>0.9%</b>	<b>68.8%</b>	<b>20.1%</b>	<b>0.0%</b>	<b>2.6%</b>	<b>1.7%</b>	<b>0.6%</b>	<b>1.7%</b>	<b>3.3%</b>	<b>0.2%</b>	<b>0.0%</b>	<b>0.0%</b>	<b>0.1%</b>	<b>0.0%</b>		

# Southern Traffic Services, Inc.

## Vehicle Counts

**US 41 between CR 676A (Madison Ave) & CR 676 (Causeway Blvd) Southbound 27.91473 , -82.40190**

**Datasets:**

**Site:** [15sbfast] !7049  
**Site:** [15sbmid] !7049  
**Site:** [15sbslow] !6543  
**Direction:** 3 - South bound, A hit first., Lane: 1  
**Survey Duration:** 8:00 Monday, January 28, 2013 => 11:45 Friday, February 01, 2013  
**File:** G:\DATA\2013\Private\13015\diego0128\13015\UM15sbslow.eco (Plus)  
**Identifier:** AR32XKW4 MC56-L5 [MC55] (c)Microcom 19Oct04  
**Algorithm:** Factory default  
**Data type:** Axle sensors - Paired (Class, Speed, Count)

**Profile:**

**Filter time:** 0:00 Tuesday, January 29, 2013 => 0:00 Friday, February 01, 2013  
**Included classes:** 1, 2, 3, 4, 5, 6, 7, 8, 9, 10, 11, 12, 13, 14  
**Speed range:** 0 - 100 mph.  
**Direction:** South (bound)  
**Separation:** All - (Headway)  
**Name:** Factory default profile  
**Scheme:** Vehicle classification (FLDOT)  
**Units:** Non metric (ft, mi, ft/s, mph, lb, ton)  
**In profile:** Vehicles = 53701

**Tuesday, January 29, 2013 - Total=17753, 15 minute drops**

0000	0100	0200	0300	0400	0500	0600	0700	0800	0900	1000	1100	1200	1300	1400	1500	1600	1700	1800	1900	2000	2100	2200	2300	
144	86	89	122	196	346	833	737	732	765	741	708	737	1051	942	1344	1914	2215	1423	857	581	474	461	255	
42	19	24	24	31	53	213	178	193	212	191	176	225	375	202	253	478	481	428	263	135	112	100	74	53
41	24	20	37	39	79	162	192	209	169	162	173	223	203	253	286	401	621	410	226	186	132	132	62	5
35	25	28	20	62	125	248	178	146	198	181	188	217	227	266	428	489	558	312	211	141	138	131	66	63
26	18	17	41	64	89	210	189	184	186	207	171	72	246	221	377	546	555	273	157	119	92	98	53	32

**AM Peak 1145 - 1245 (836), AM PHF=0.93 PM Peak 1700 - 1800 (2215), PM PHF=0.89**

**Wednesday, January 30, 2013 - Total=17858, 15 minute drops**

0000	0100	0200	0300	0400	0500	0600	0700	0800	0900	1000	1100	1200	1300	1400	1500	1600	1700	1800	1900	2000	2100	2200	2300	
153	104	105	116	200	415	760	788	797	584	766	770	896	886	973	1430	1902	2281	1460	752	494	543	404	279	
53	25	20	18	44	46	145	205	180	150	194	168	201	200	218	276	421	591	454	240	125	144	131	90	50
5	27	25	27	41	99	199	209	261	127	171	195	241	208	184	336	454	550	379	196	122	153	110	60	51
63	16	39	37	52	114	243	174	202	118	225	217	242	258	302	393	536	561	356	118	140	157	99	73	40
32	36	21	34	63	156	173	200	154	189	176	190	212	220	269	425	491	579	271	198	107	89	64	56	27

**AM Peak 1145 - 1245 (874), AM PHF=0.90 PM Peak 1700 - 1800 (2281), PM PHF=0.96**

**Thursday, January 31, 2013 - Total=18090, 15 minute drops**

0000	0100	0200	0300	0400	0500	0600	0700	0800	0900	1000	1100	1200	1300	1400	1500	1600	1700	1800	1900	2000	2100	2200	2300	
168	117	87	97	190	388	767	844	721	645	689	853	916	660	1282	1434	1855	2083	1628	838	653	539	392	244	
50	41	25	25	35	64	138	209	204	166	130	209	218	186	467	312	460	514	497	271	157	138	100	61	45
51	24	27	16	29	84	212	224	176	152	194	196	212	265	224	362	428	510	469	174	176	137	100	66	46
40	25	13	26	61	110	243	207	116	159	194	231	259	190	292	363	481	515	339	236	182	142	96	61	47
27	27	22	30	65	130	174	204	225	168	171	217	227	19	299	397	486	544	323	157	138	122	96	56	24

**AM Peak 1145 - 1245 (906), AM PHF=0.87 PM Peak 1700 - 1800 (2083), PM PHF=0.96**

# Southern Traffic Services, Inc.

## Classification Count

**US 41 between CR 676A (Madison Ave) & CR 676 (Causeway Blvd) Southbound 27.91473 , -82.40190**

**Datasets:**

**Site:** [15sbfast] !4429  
**Site:** [15sbmid] !4429  
**Site:** [15sbslow] !9031  
**Direction:** 3 - South bound, A hit first., Lane: 1  
**Survey Duration:** 8:00 Monday, January 28, 2013 => 11:45 Friday, February 01, 2013  
**File:** G:\DATA\2013\Private\13015\diego0128\13015\UM15sbslow.eco (Plus)  
**Identifier:** AR32XKW4 MC56-L5 [MC55] (c)Microcom 19Oct04  
**Algorithm:** Factory default  
**Data type:** Axle sensors - Paired (Class, Speed, Count)

**Profile:**

**Filter time:** 0:00 Tuesday, January 29, 2013 => 0:00 Friday, February 01, 2013  
**Included classes:** 1, 2, 3, 4, 5, 6, 7, 8, 9, 10, 11, 12, 13, 14  
**Speed range:** 0 - 100 mph.  
**Direction:** South (bound)

**Tuesday, January 29, 2013**

Time	Total	Cls 1	Cls 2	Cls 3	Cls 4	Cls 5	Cls 6	Cls 7	Cls 8	Cls 9	Cls 10	Cls 11	Cls 12	Cls 13	Cls 14
0000	42	0	28	10	0	0	0	0	2	2	0	0	0	0	0
0015	41	1	34	2	0	0	0	0	0	4	0	0	0	0	0
0030	35	3	23	7	0	0	0	0	0	2	0	0	0	0	0
0045	26	1	16	5	0	0	0	0	0	3	1	0	0	0	0
0100	19	0	13	3	0	0	0	0	0	3	0	0	0	0	0
0115	24	0	19	2	0	0	0	0	0	3	0	0	0	0	0
0130	25	1	20	3	0	0	0	0	0	1	0	0	0	0	0
0145	18	0	11	3	0	0	1	0	0	3	0	0	0	0	0
0200	24	1	17	2	0	0	0	0	0	3	0	1	0	0	0
0215	20	0	13	3	0	0	1	0	0	3	0	0	0	0	0
0230	28	0	19	7	0	1	0	0	0	1	0	0	0	0	0
0245	17	1	7	4	0	0	0	0	0	4	1	0	0	0	0
0300	24	0	16	4	0	0	0	0	2	2	0	0	0	0	0
0315	37	0	18	5	0	0	3	0	0	10	1	0	0	0	0
0330	20	0	14	3	0	0	0	0	1	2	0	0	0	0	0
0345	41	0	29	5	0	0	1	0	1	5	0	0	0	0	0
0400	31	0	15	4	0	0	2	0	5	3	0	0	0	2	0
0415	40	0	26	8	0	0	0	0	2	4	0	0	0	0	0
0430	61	0	37	13	0	0	2	0	1	8	0	0	0	0	0
0445	64	0	34	16	0	1	1	0	0	11	1	0	0	0	0
0500	53	0	32	10	0	1	1	0	2	6	0	0	0	1	0
0515	79	1	52	19	0	1	2	0	2	2	0	0	0	0	0
0530	125	1	70	27	0	4	5	0	2	14	1	0	0	1	0
0545	89	3	56	16	0	2	3	0	0	8	1	0	0	0	0
0600	213	1	123	64	0	5	6	0	2	9	2	0	1	0	0
0615	162	0	104	37	0	3	7	0	3	7	1	0	0	0	0
0630	248	3	155	65	0	8	4	0	3	8	1	0	0	1	0
0645	211	2	122	61	0	5	11	0	2	8	0	0	0	0	0
0700	177	1	117	33	0	5	9	1	4	6	1	0	0	0	0
0715	192	3	118	38	0	11	4	2	6	7	3	0	0	0	0
0730	178	3	98	38	0	13	9	1	7	8	0	0	0	1	0
0745	190	3	123	37	0	5	6	4	8	4	0	0	0	0	0
0800	192	1	126	41	0	3	2	2	5	11	1	0	0	0	0
0815	209	1	134	50	0	6	7	0	5	6	0	0	0	0	0
0830	146	1	85	33	2	4	4	2	4	9	1	0	0	1	0
0845	185	0	100	41	0	11	6	6	9	11	0	0	0	1	0
0900	211	0	125	34	0	12	10	4	8	16	2	0	0	0	0
0915	169	0	92	37	0	11	6	5	5	13	0	0	0	0	0
0930	198	1	121	41	1	6	10	3	5	10	0	0	0	0	0
0945	186	2	95	43	1	11	6	6	6	14	2	0	0	0	0

1000	191	1	101	43	0	11	8	5	7	13	1	0	0	1	0
1015	162	3	75	52	0	4	6	1	6	15	0	0	0	0	0
1030	181	0	102	46	0	7	8	5	5	8	0	0	0	0	0
1045	207	3	105	53	0	13	13	2	6	11	1	0	0	0	0
1100	176	1	95	46	0	5	6	4	5	14	0	0	0	0	0
1115	173	3	99	38	0	7	8	5	5	8	0	0	0	0	0
1130	188	1	99	48	0	8	5	3	8	14	0	0	0	2	0
1145	172	1	99	30	0	12	12	1	4	12	0	0	0	1	0
1200	224	1	134	54	0	9	1	1	9	14	1	0	0	0	0
1215	223	6	135	43	1	9	9	3	9	8	0	0	0	0	0
1230	217	2	133	48	0	8	3	6	5	11	0	0	0	1	0
1245	73	0	42	17	0	7	2	0	2	2	1	0	0	0	0
1300	374	1	250	70	0	13	12	3	8	17	0	0	0	0	0
1315	204	0	127	51	0	12	0	4	3	6	1	0	0	0	0
1330	226	2	141	49	0	8	7	4	6	8	0	0	0	1	0
1345	246	2	154	43	0	16	5	3	14	8	1	0	0	0	0
1400	202	3	111	54	0	6	4	3	7	14	0	0	0	0	0
1415	254	1	166	46	0	8	10	5	5	11	1	0	0	1	0
1430	265	4	167	61	0	6	3	2	16	6	0	0	0	0	0
1445	221	10	135	52	0	6	5	1	4	8	0	0	0	0	0
1500	254	3	174	62	0	2	1	3	4	5	0	0	0	0	0
1515	285	4	175	72	0	6	4	1	13	8	0	0	0	2	0
1530	428	4	291	88	0	17	5	0	11	11	1	0	0	0	0
1545	377	2	252	94	0	8	2	2	8	9	0	0	0	0	0
1600	479	9	336	102	0	19	7	0	4	2	0	0	0	0	0
1615	400	5	278	89	0	9	6	1	4	8	0	0	0	0	0
1630	489	9	359	91	0	8	6	1	10	5	0	0	0	0	0
1645	546	10	418	93	0	7	1	0	2	14	0	0	0	1	0
1700	481	6	377	73	0	10	3	0	4	8	0	0	0	0	0
1715	621	3	489	107	0	6	2	0	3	10	0	0	0	1	0
1730	558	4	446	96	0	5	0	0	5	2	0	0	0	0	0
1745	555	3	436	94	0	9	3	0	4	5	1	0	0	0	0
1800	429	3	326	81	0	9	3	0	2	5	0	0	0	0	0
1815	409	0	317	75	0	4	2	0	4	7	0	0	0	0	0
1830	314	2	250	52	0	2	0	0	4	4	0	0	0	0	0
1845	271	0	218	43	0	3	2	0	3	2	0	0	0	0	0
1900	263	3	210	42	0	1	0	0	4	3	0	0	0	0	0
1915	227	4	179	35	0	2	1	0	2	4	0	0	0	0	0
1930	210	0	158	46	0	1	1	0	2	2	0	0	0	0	0
1945	158	1	128	22	0	1	0	0	0	6	0	0	0	0	0
2000	134	1	116	13	0	0	0	0	2	2	0	0	0	0	0
2015	186	1	157	21	0	4	0	0	0	3	0	0	0	0	0
2030	141	5	111	20	0	0	0	0	0	5	0	0	0	0	0
2045	119	4	95	16	0	2	0	0	1	1	0	0	0	0	0
2100	112	1	94	17	0	0	0	0	0	0	0	0	0	0	0
2115	132	2	107	22	0	1	0	0	0	0	0	0	0	0	0
2130	138	2	115	17	0	3	1	0	0	0	0	0	0	0	0
2145	92	3	74	13	0	0	0	0	1	1	0	0	0	0	0
2200	100	0	80	17	0	1	0	0	0	2	0	0	0	0	0
2215	132	0	109	19	0	1	0	0	0	3	0	0	0	0	0
2230	131	2	102	25	0	2	0	0	0	0	0	0	0	0	0
2245	98	1	71	20	0	2	0	0	1	3	0	0	0	0	0
2300	74	1	59	11	0	2	0	0	0	1	0	0	0	0	0
2315	62	1	53	6	0	0	0	0	0	2	0	0	0	0	0
2330	66	2	53	8	0	0	0	0	0	3	0	0	0	0	0
2345	53	4	35	11	0	0	0	0	0	3	0	0	0	0	0
<b>00-00</b>	<b>17753</b>	<b>185</b>	<b>12175</b>	<b>3531</b>	<b>5</b>	<b>451</b>	<b>306</b>	<b>105</b>	<b>334</b>	<b>611</b>	<b>29</b>	<b>1</b>	<b>1</b>	<b>19</b>	<b>0</b>

**Wednesday, January 30, 2013**

Time	Total	Cls													
		1	2	3	4	5	6	7	8	9	10	11	12	13	14
0000	53	2	38	12	0	0	0	0	0	1	0	0	0	0	0
0015	5	0	4	1	0	0	0	0	0	0	0	0	0	0	0
0030	63	1	48	10	0	0	0	0	0	3	0	0	0	1	0
0045	32	1	21	7	0	0	0	0	0	3	0	0	0	0	0
0100	25	1	19	4	0	0	0	0	0	1	0	0	0	0	0
0115	27	0	20	1	0	0	3	0	0	3	0	0	0	0	0
0130	16	0	13	3	0	0	0	0	0	0	0	0	0	0	0
0145	36	0	22	8	0	0	1	0	1	4	0	0	0	0	0
0200	20	0	12	6	0	0	0	0	0	2	0	0	0	0	0



0215	25	0	14	6	0	0	1	0	0	3	0	0	0	1	0
0230	39	1	27	4	0	0	2	0	0	5	0	0	0	0	0
0245	21	0	8	7	0	0	0	0	0	6	0	0	0	0	0
0300	18	0	8	4	0	0	2	0	1	3	0	0	0	0	0
0315	27	0	14	6	0	0	0	0	0	6	1	0	0	0	0
0330	37	0	29	5	0	1	1	0	0	1	0	0	0	0	0
0345	34	0	20	5	0	1	1	0	1	6	0	0	0	0	0
0400	45	1	37	3	0	0	1	1	0	2	0	0	0	0	0
0415	40	0	26	6	0	0	0	0	2	6	0	0	0	0	0
0430	52	1	29	15	0	1	0	0	2	3	1	0	0	0	0
0445	63	0	35	13	0	4	2	0	2	7	0	0	0	0	0
0500	46	0	35	5	0	0	2	0	1	2	1	0	0	0	0
0515	99	0	63	24	0	0	4	0	3	5	0	0	0	0	0
0530	114	2	67	24	1	3	9	1	2	4	1	0	0	0	0
0545	156	2	78	46	0	2	11	0	4	12	1	0	0	0	0
0600	145	2	77	46	0	2	8	0	1	9	0	0	0	0	0
0615	200	2	126	56	0	4	4	0	2	6	0	0	0	0	0
0630	242	3	143	72	0	7	7	0	1	7	2	0	0	0	0
0645	173	3	113	36	0	4	7	1	2	6	0	0	0	1	0
0700	205	2	142	33	0	4	6	1	9	6	2	0	0	0	0
0715	210	4	132	33	1	13	7	0	7	12	1	0	0	0	0
0730	174	0	116	34	0	4	9	2	5	3	0	0	0	1	0
0745	199	1	120	45	0	7	7	4	6	6	2	0	0	1	0
0800	181	2	114	35	0	6	3	1	8	9	2	0	0	1	0
0815	260	3	153	59	0	13	7	5	2	15	2	0	0	1	0
0830	203	1	104	59	0	8	3	2	13	12	1	0	0	0	0
0845	153	1	95	34	0	6	3	2	4	7	1	0	0	0	0
0900	150	1	79	30	0	5	4	10	9	11	0	0	0	1	0
0915	127	2	66	34	0	8	4	3	3	6	0	0	0	1	0
0930	118	0	60	26	0	7	7	2	4	11	0	0	0	1	0
0945	189	1	97	42	0	10	15	10	5	9	0	0	0	0	0
1000	194	1	100	50	0	8	6	3	11	14	1	0	0	0	0
1015	171	1	89	48	0	2	4	6	7	14	0	0	0	0	0
1030	226	1	128	46	0	10	9	8	8	15	1	0	0	0	0
1045	175	1	106	32	0	13	4	1	5	12	0	1	0	0	0
1100	168	1	87	36	0	14	3	9	7	10	0	0	0	1	0
1115	195	3	103	49	1	12	5	5	6	10	0	0	0	1	0
1130	217	1	117	49	0	11	12	4	5	16	1	0	0	1	0
1145	190	0	102	53	0	6	7	4	4	13	0	0	0	1	0
1200	201	3	109	45	1	7	7	2	12	12	2	0	0	1	0
1215	242	1	140	67	0	8	5	0	7	13	1	0	0	0	0
1230	241	0	154	53	0	11	6	1	4	11	1	0	0	0	0
1245	212	2	118	59	0	7	2	9	5	10	0	0	0	0	0
1300	201	5	114	48	0	8	10	2	4	10	0	0	0	0	0
1315	207	0	126	45	0	9	7	4	2	12	0	0	0	2	0
1330	258	1	151	61	0	12	10	7	6	8	1	0	0	1	0
1345	220	4	130	41	0	14	7	2	9	10	1	0	0	2	0
1400	219	3	133	37	0	8	3	7	11	16	0	0	0	1	0
1415	183	2	113	42	0	9	2	3	7	5	0	0	0	0	0
1430	302	4	194	65	1	11	4	3	6	13	1	0	0	0	0
1445	269	3	173	57	0	12	5	2	11	6	0	0	0	0	0
1500	276	2	180	50	1	14	4	4	7	13	0	0	0	1	0
1515	337	4	228	73	0	7	4	2	7	11	1	0	0	0	0
1530	392	3	267	93	0	6	1	5	10	7	0	0	0	0	0
1545	426	5	285	102	2	16	2	1	7	6	0	0	0	0	0
1600	421	5	289	93	0	12	9	0	8	5	0	0	0	0	0
1615	454	2	333	97	0	6	2	2	3	9	0	0	0	0	0
1630	535	7	414	89	0	8	5	0	3	9	0	0	0	0	0
1645	492	6	357	97	0	6	4	0	7	15	0	0	0	0	0
1700	590	5	480	91	0	8	3	0	1	2	0	0	0	0	0
1715	551	5	428	94	1	12	3	0	4	3	0	0	0	1	0
1730	561	3	432	107	0	9	1	0	5	4	0	0	0	0	0
1745	578	3	449	115	0	6	1	0	3	1	0	0	0	0	0
1800	454	4	348	82	0	5	2	0	6	6	0	0	0	1	0
1815	379	3	297	69	0	1	2	0	3	4	0	0	0	0	0
1830	357	4	278	59	0	8	2	0	3	3	0	0	0	0	0
1845	270	3	194	58	0	9	0	0	1	5	0	0	0	0	0
1900	240	0	181	45	0	4	1	0	4	5	0	0	0	0	0
1915	196	3	147	36	0	2	0	0	4	4	0	0	0	0	0
1930	118	1	92	23	0	1	0	0	0	1	0	0	0	0	0

1945	198	0	161	30	0	0	2	0	1	4	0	0	0	0	0
2000	125	1	102	19	0	1	0	0	0	2	0	0	0	0	0
2015	122	3	91	23	0	2	0	0	1	2	0	0	0	0	0
2030	140	1	113	25	0	0	0	0	0	1	0	0	0	0	0
2045	107	1	78	24	0	1	0	0	1	1	1	0	0	0	0
2100	144	2	118	20	1	0	0	0	0	2	0	0	0	1	0
2115	153	2	124	23	0	1	1	0	0	2	0	0	0	0	0
2130	157	2	125	24	0	1	0	0	0	5	0	0	0	0	0
2145	89	2	69	11	0	2	1	0	1	3	0	0	0	0	0
2200	131	2	108	17	0	1	0	0	1	2	0	0	0	0	0
2215	110	3	86	17	0	2	1	0	0	1	0	0	0	0	0
2230	99	1	74	22	0	0	0	0	0	2	0	0	0	0	0
2245	64	2	52	7	0	0	0	0	1	2	0	0	0	0	0
2300	90	1	73	13	0	0	1	0	0	2	0	0	0	0	0
2315	60	0	48	10	0	0	0	0	1	1	0	0	0	0	0
2330	73	2	56	12	0	0	2	0	0	1	0	0	0	0	0
2345	56	1	47	7	0	0	0	0	0	1	0	0	0	0	0
<b>00-00</b>	<b>17858</b>	<b>171</b>	<b>12115</b>	<b>3659</b>	<b>10</b>	<b>463</b>	<b>313</b>	<b>141</b>	<b>330</b>	<b>600</b>	<b>30</b>	<b>1</b>	<b>0</b>	<b>25</b>	<b>0</b>

**Thursday, January 31, 2013**

Time	Total	Cls 1	Cls 2	Cls 3	Cls 4	Cls 5	Cls 6	Cls 7	Cls 8	Cls 9	Cls 10	Cls 11	Cls 12	Cls 13	Cls 14
0000	50	0	40	8	0	1	0	0	0	1	0	0	0	0	0
0015	51	1	37	8	0	1	0	0	0	4	0	0	0	0	0
0030	40	0	30	8	0	0	0	0	0	2	0	0	0	0	0
0045	27	0	20	5	0	0	0	0	0	1	1	0	0	0	0
0100	41	0	37	3	0	0	0	0	0	1	0	0	0	0	0
0115	24	0	15	4	0	1	0	0	0	4	0	0	0	0	0
0130	25	0	18	3	0	0	1	0	0	3	0	0	0	0	0
0145	27	0	18	4	0	1	0	0	0	3	0	1	0	0	0
0200	25	1	18	4	0	2	0	0	0	0	0	0	0	0	0
0215	27	0	18	3	0	0	1	0	2	3	0	0	0	0	0
0230	13	0	7	2	0	0	1	0	1	2	0	0	0	0	0
0245	22	1	10	6	0	0	0	0	0	5	0	0	0	0	0
0300	25	1	12	7	0	0	0	0	0	5	0	0	0	0	0
0315	16	0	10	2	0	0	1	0	0	3	0	0	0	0	0
0330	26	1	17	3	0	0	1	0	0	3	1	0	0	0	0
0345	30	0	17	5	0	2	1	0	1	4	0	0	0	0	0
0400	35	0	19	5	0	0	1	0	2	7	1	0	0	0	0
0415	29	0	14	4	0	0	6	0	1	4	0	0	0	0	0
0430	61	1	41	9	0	0	1	0	0	9	0	0	0	0	0
0445	65	0	37	14	0	4	1	0	2	6	1	0	0	0	0
0500	64	1	35	14	0	3	2	0	2	6	1	0	0	0	0
0515	84	0	57	16	0	2	0	0	0	9	0	0	0	0	0
0530	110	1	67	27	0	7	1	0	2	4	1	0	0	0	0
0545	131	1	86	34	0	2	4	0	1	3	0	0	0	0	0
0600	139	1	87	38	0	1	5	0	1	5	0	0	0	1	0
0615	210	1	133	54	0	3	5	0	2	12	0	0	0	0	0
0630	243	0	162	66	0	4	3	1	1	6	0	0	0	0	0
0645	175	1	114	44	0	2	4	1	1	5	3	0	0	0	0
0700	208	4	148	34	0	2	7	3	2	7	1	0	0	0	0
0715	225	0	159	43	0	7	4	3	5	3	0	0	0	1	0
0730	206	0	138	36	0	14	2	8	3	3	2	0	0	0	0
0745	203	0	131	42	0	8	5	4	5	8	0	0	0	0	0
0800	205	1	132	40	0	11	8	2	0	9	2	0	0	0	0
0815	176	0	111	38	0	7	4	1	5	9	0	0	0	1	0
0830	116	0	68	32	0	0	6	1	3	4	2	0	0	0	0
0845	225	1	134	52	0	16	5	2	3	11	0	0	0	1	0
0900	166	0	97	39	0	6	8	5	2	8	1	0	0	0	0
0915	152	1	74	48	0	8	4	3	9	4	1	0	0	0	0
0930	159	0	89	36	0	9	3	5	3	13	1	0	0	0	0
0945	168	0	97	41	0	6	4	3	5	11	1	0	0	0	0
1000	130	1	74	24	0	10	3	6	5	6	0	0	0	1	0
1015	194	2	98	54	0	8	5	3	2	16	6	0	0	0	0
1030	194	1	90	60	0	14	10	0	8	9	2	0	0	0	0
1045	172	1	105	37	0	7	7	1	6	7	1	0	0	0	0
1100	208	0	110	53	0	9	11	2	9	14	0	0	0	0	0
1115	196	1	123	34	0	13	5	0	6	12	2	0	0	0	0
1130	231	2	128	66	0	6	3	1	6	18	1	0	0	0	0
1145	217	1	130	46	1	6	15	1	7	8	1	0	0	1	0

1200	218	4	126	52	0	15	4	0	6	9	1	0	0	1	0
1215	212	1	120	55	0	12	8	0	5	11	0	0	0	0	0
1230	260	5	155	58	0	13	5	1	8	14	0	0	0	1	0
1245	226	0	140	52	0	11	2	1	6	13	1	0	0	0	0
1300	186	0	110	51	0	6	6	0	5	8	0	0	0	0	0
1315	265	2	160	76	1	6	7	0	3	9	1	0	0	0	0
1330	190	0	115	51	0	5	6	0	5	8	0	0	0	0	0
1345	19	1	10	4	0	1	0	0	1	2	0	0	0	0	0
1400	468	3	300	96	0	17	13	3	9	23	2	0	0	2	0
1415	223	1	147	49	0	6	2	1	5	12	0	0	0	0	0
1430	292	1	193	60	1	15	3	0	5	13	0	0	0	1	0
1445	299	2	198	52	0	17	8	1	9	12	0	0	0	0	0
1500	312	0	220	63	0	14	2	0	8	5	0	0	0	0	0
1515	363	3	234	88	0	13	7	0	10	8	0	0	0	0	0
1530	364	2	245	85	0	14	9	0	3	5	1	0	0	0	0
1545	396	2	256	93	0	15	9	1	8	11	0	0	0	1	0
1600	459	2	333	108	0	7	2	0	3	4	0	0	0	0	0
1615	428	9	323	77	2	10	4	0	2	1	0	0	0	0	0
1630	482	4	380	71	2	8	2	0	6	8	1	0	0	0	0
1645	487	4	384	76	0	8	4	0	1	10	0	0	0	0	0
1700	513	3	391	89	0	9	7	0	7	6	1	0	0	0	0
1715	509	1	411	83	0	6	2	0	4	2	0	0	0	0	0
1730	515	1	420	82	0	5	2	0	4	1	0	0	0	0	0
1745	545	4	447	73	0	6	6	0	4	5	0	0	0	0	0
1800	497	3	384	94	0	6	2	0	3	5	0	0	0	0	0
1815	468	0	383	69	0	3	6	0	4	2	1	0	0	0	0
1830	339	1	274	51	1	7	3	0	1	1	0	0	0	0	0
1845	323	2	259	53	0	3	2	0	1	3	0	0	0	0	0
1900	271	0	222	38	0	3	2	0	3	3	0	0	0	0	0
1915	174	1	129	37	0	4	1	0	0	2	0	0	0	0	0
1930	237	1	179	42	0	3	2	0	2	7	1	0	0	0	0
1945	156	1	123	24	0	3	1	0	3	1	0	0	0	0	0
2000	157	0	129	26	0	0	0	0	0	2	0	0	0	0	0
2015	176	2	138	28	0	1	0	0	4	3	0	0	0	0	0
2030	182	1	142	34	0	3	0	0	1	1	0	0	0	0	0
2045	138	2	114	19	0	1	0	0	2	0	0	0	0	0	0
2100	138	0	111	23	0	2	0	0	0	1	0	0	0	1	0
2115	137	0	110	25	0	2	0	0	0	0	0	0	0	0	0
2130	142	1	118	19	0	2	1	0	0	0	1	0	0	0	0
2145	122	0	101	19	0	0	1	0	1	0	0	0	0	0	0
2200	100	2	77	17	0	2	0	0	0	2	0	0	0	0	0
2215	100	2	81	11	0	1	0	0	1	4	0	0	0	0	0
2230	96	1	72	18	0	1	0	0	1	3	0	0	0	0	0
2245	96	0	77	15	0	1	0	0	0	3	0	0	0	0	0
2300	61	0	47	9	1	1	0	0	0	2	1	0	0	0	0
2315	66	1	59	4	0	0	0	0	0	2	0	0	0	0	0
2330	61	1	45	10	1	1	0	0	0	3	0	0	0	0	0
2345	56	0	41	10	0	1	2	0	0	2	0	0	0	0	0
<b>00-00</b>	<b>18090</b>	<b>105</b>	<b>12645</b>	<b>3594</b>	<b>10</b>	<b>493</b>	<b>301</b>	<b>64</b>	<b>267</b>	<b>552</b>	<b>45</b>	<b>1</b>	<b>0</b>	<b>13</b>	<b>0</b>

**Grand Total**

<b>Time</b>	<b>Total</b>	<b>Cls</b>	<b>Cls</b>	<b>Cls</b>	<b>Cls</b>	<b>Cls</b>	<b>Cls</b>	<b>Cls</b>	<b>Cls</b>	<b>Cls</b>	<b>Cls</b>	<b>Cls</b>	<b>Cls</b>	<b>Cls</b>	<b>Cls</b>
		<b>1</b>	<b>2</b>	<b>3</b>	<b>4</b>	<b>5</b>	<b>6</b>	<b>7</b>	<b>8</b>	<b>9</b>	<b>10</b>	<b>11</b>	<b>12</b>	<b>13</b>	<b>14</b>
--	53701	461	36935	10784	25	1407	920	310	931	1763	104	3	1	57	0

# Appendix B

## Memorandum on Recommended Design Hour Traffic Factors and Development of Existing and Future Traffic Volumes

**MEMORANDUM****DRAFT**

**Date:** May 31, 2013

**To:** Waddah Farah  
Peter Maass, PE, PTOE  
David Winkle, AICP  
Florida Department of Transportation (FDOT), District Seven

**From:** Akram Hussein, PE, PTOE and Arpita Guha, PE

**Cc:** Rick Adair (FDOT Project Manager)





**Subject:** US 41 PD&E Study from Kracker Avenue to South of SR 676 (Causeway Boulevard)  
FPID: 430056-1-22-01  
Recommended Design Hour Traffic Factors and  
Development of Existing and Future Traffic Volumes

American Project No: 5127041

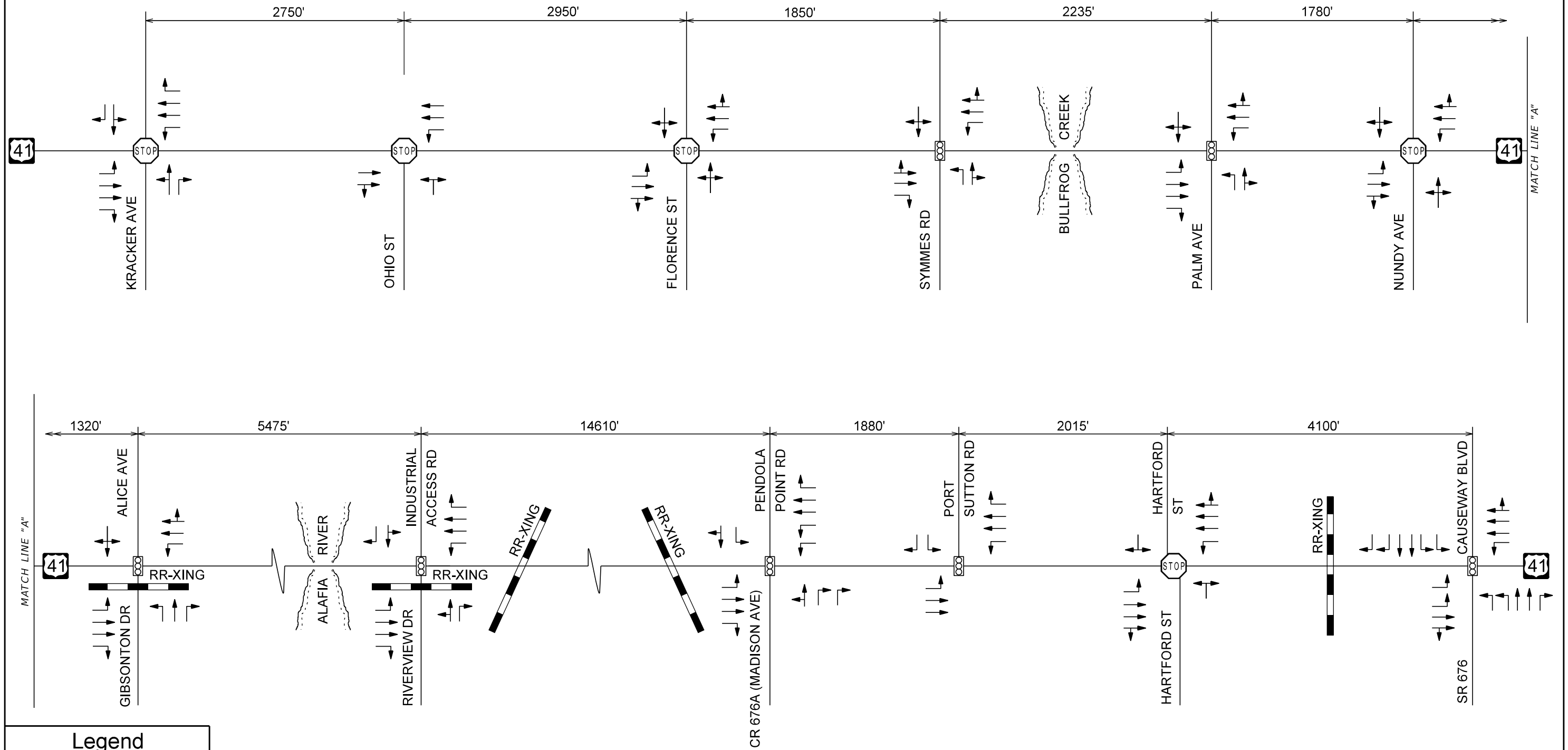
The purpose of this technical memorandum is to document the recommended design hour traffic factors and to describe the methodology used for the development of the existing and future traffic volumes for US 41 project corridor. The project limits along US 41 (Roadway ID: 10060000) extend from Kracker Avenue to South of SR 676 (Causeway Boulevard) for approximately 8.0 miles. The existing lane geometry is shown in **Figure 1**.

Traffic count information including turning movement counts, 72-hour approach counts and 72-hour classification counts were conducted by Southern Traffic Services, Inc. during January 2013 and is provided in **Appendix A**. Additional turning movement counts were conducted between 9 am and 1 pm when truck traffic was observed to be the highest at the intersection of Riverview Drive, Madison Avenue, and Port Sutton Road which provide direct connection to the Port of Tampa facilities. These special counts were conducted in order to size the future turn lanes at these intersections so that they can accommodate high-volume truck movements made throughout an average day. These additional turning movement counts are also



Legend	
	TRAFFIC SIGNAL
	STOP SIGN (SIDE STREET ONLY)
	LANES
	DISTANCE IN FEET
	RAILROAD CROSSING

NOTE:  
 NOT ALL SIDE STREETS ARE SHOWN.  
 ONLY INTERSECTIONS ANALYZED ARE SHOWN.

**US 41 PD&E Study**  
*From Kracker Avenue to South  
 of SR 676 (Causeway Boulevard)*  
 WPI Number: 430056-1  
 Hillsborough County

Existing Lane Geometry

Figure 1

included in **Appendix A**.

### **Recommended Design Hour Traffic Factors**

The design hour traffic factors recommended for the US 41 PD&E study includes a standard K factor of 9.0% per the 2012 Project Traffic Forecasting Handbook along US 41 and all the side-streets. The recommended D-factor along the US 41 study corridor is 64.27% based on the average of the D-factors obtained from the 72-hour classification counts and the D-factor along the study corridor as identified in the 2011 Florida Transportation Information (FTI) DVD. The recommended D-factor along US 41 is within the acceptable range identified in the 2012 FDOT Project Traffic Forecasting Handbook. D-factor along the side-streets that were used in the development of the existing AM and PM peak hour traffic volumes were estimated from the actual AM and PM peak hour turning movement counts. Information for D-factor for US 41 and the side-streets are provided in **Appendix B**. These recommended K and D factors will be used for the development of existing and future traffic volumes.

Recommended daily truck percentage ( $T_{24}$ ) along the study corridor based on the 72-hour classification counts are 9.0% between Kracker Avenue and Gibsonton Drive and between Gibsonton Drive and CR 676A (Madison Avenue); and, 11.0% between CR 676A (Madison Avenue) and south of SR 676 (Causeway Boulevard). For the existing and future analysis along the side-streets, design hour truck (DHT) will be used based on the AM and PM peak hour turning movement counts. DHT for US 41 is assumed to be half of  $T_{24}$ , rounded up to the nearest percent. Information on DHT for side-streets is provided in **Appendix B**.

**Table 1** below shows the recommended design traffic factors for the US 41 corridor. The information on the design traffic factors for US 41 is provided in **Appendix B**.

**Table 1: Recommended K, D, T Factors along US 41**

US 41	K	D	Daily Truck (T <sub>24</sub> )	Design Hour Truck (DHT)
Kracker Avenue to Gibsonton Drive	9.00%	64.27%	9.0%	5.0%
Gibsonton Drive to CR 676A (Madison Avenue)			9.0%	5.0%
CR 676A (Madison Avenue) to south of SR 676 (Causeway Boulevard)			11.0%	5.0%

Peak Hour Factor (PHF) of 0.95 is being recommended for use in the existing and the future analysis for this study.

**Development of Existing Traffic Volumes**

The existing year (2013) AM and PM peak hour directional traffic volumes (DDHV) were obtained by multiplying the existing AADT volumes by the recommended K and D factors, respectively. The existing AADT volumes are obtained by applying both seasonal and axle factors adjustment to the raw ADTs from the 72-hour approach counts. The adjusted AADT volumes in the study area are shown in **Figure 2** and all the information related to the AADTs along with the adjustment factors is included in **Appendix C**.

The AM and PM peak hour turning movement volumes were developed by applying the existing turning percentages to the DDHV estimated from AADTs. The existing turning percentages are obtained from the AM (proposed peak: 7:00am – 8:00am) and the PM (proposed peak: 4:45pm – 5:45pm) peak hour raw turning movement counts. Based on the traffic counts, southbound is considered to be the peak direction along US 41 within the project limits during the PM peak period in the development of the peak hour turning volumes. For the AM peak, northbound for US 41 (reverse of the PM peak) was used to be the peak direction. Peak direction for each side-street was also calculated and included in **Appendix B**.

The existing year (2013) AM and PM peak hour volumes are shown in **Figure 3**. Calculation of the DDHV and the AM and PM peak hour turning movements are provided in **Appendix D**. The spreadsheets illustrating the development of the existing traffic AM and PM peak hour volumes are included in **Appendix E**.



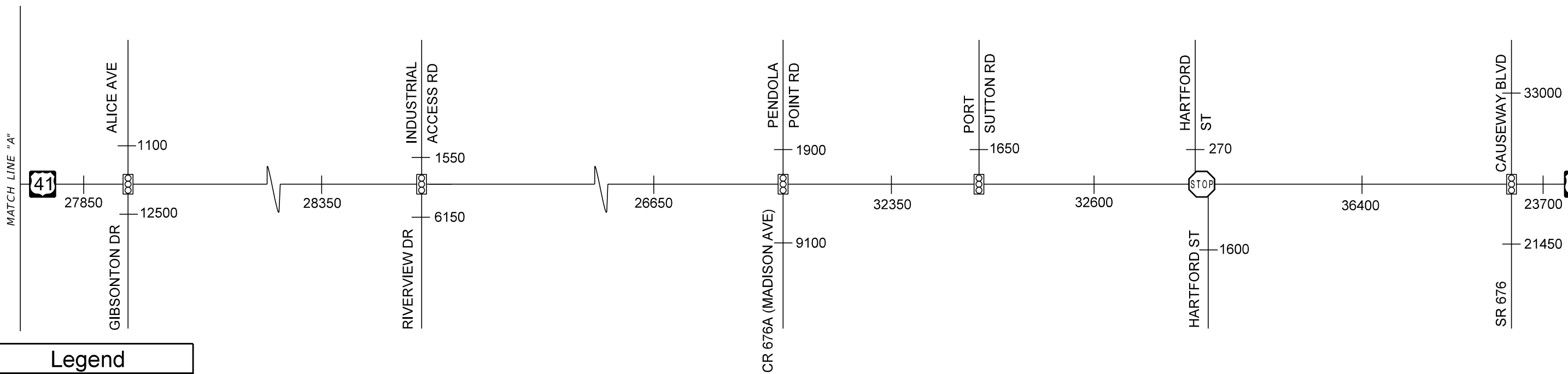
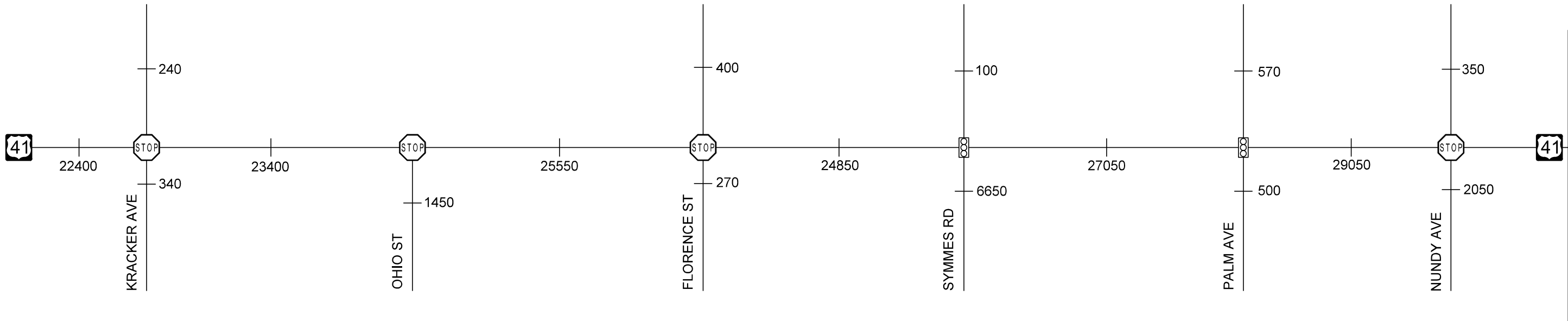



Legend	
	TRAFFIC SIGNAL
	STOP SIGN (SIDE STREET ONLY)
1234	AADTS

**US 41 PD&E Study**  
*From Kracker Avenue to South of SR 676 (Causeway Boulevard)*  
 WPI Number: 430056-1  
 Hillsborough County

Existing (2013) Annual Average Daily Traffic (AADT)

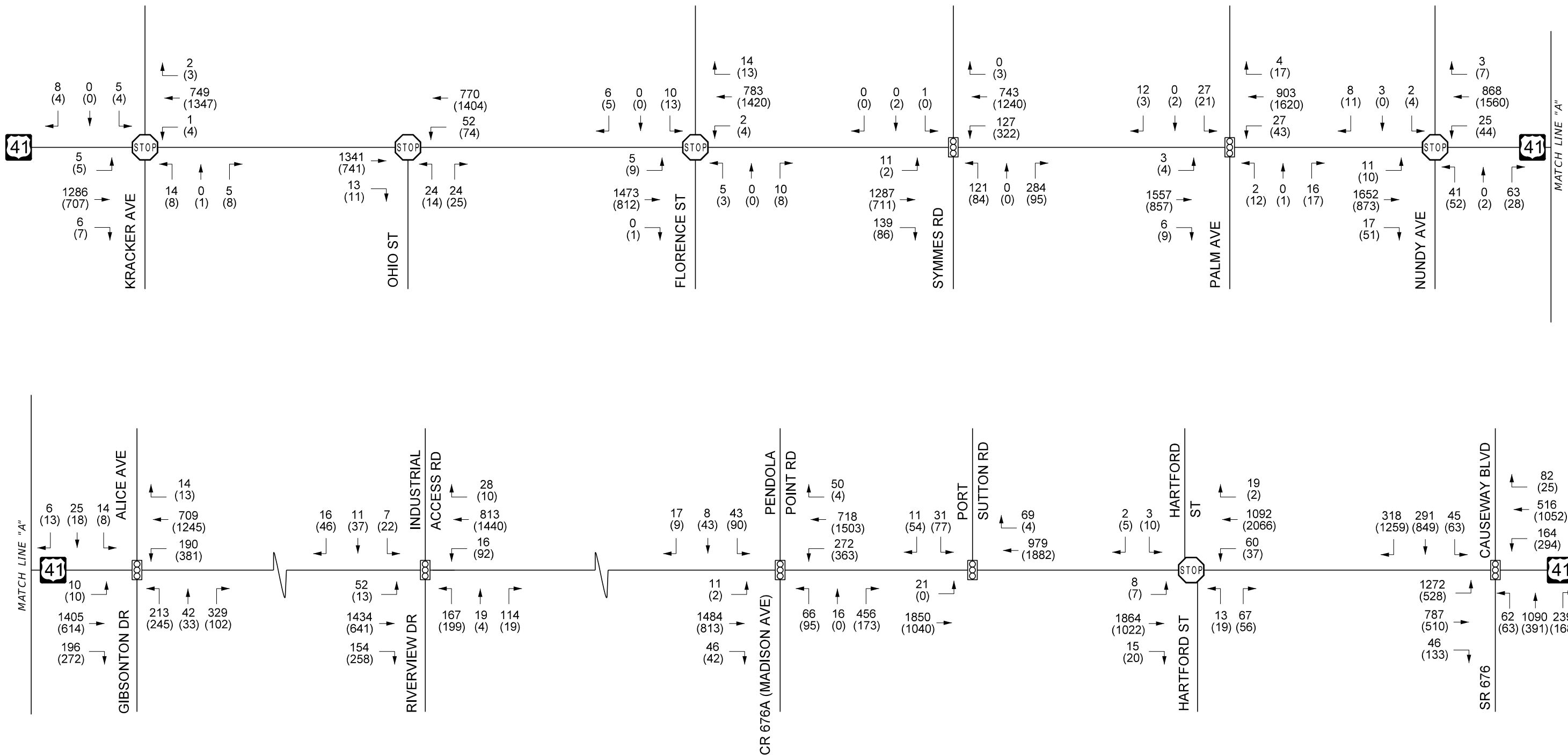
Figure 2



Legend	
	TRAFFIC SIGNAL
	STOP SIGN (SIDE STREET ONLY)
1234	AM PEAK HOUR VOLUME
(1234)	(PM PEAK HOUR VOLUME)

**US 41 PD&E Study**  
*From Kracker Avenue to South of SR 676 (Causeway Boulevard)*  
 WPI Number: 430056-1  
 Hillsborough County

Year 2013 AM and PM Peak Hour Traffic Volumes

Figure 3

### **Development of Future Traffic Volumes**

As indicated in the traffic methodology, already approved by Florida Department of Transportation (FDOT) - District 7 in January 2013, only one set of future traffic volumes were developed that will be used for both the no-build and the build conditions. The approved traffic methodology has been included in **Appendix B**.

For the development of the future traffic volumes, Tampa Bay Regional Planning Model (TBRPM) version 7.1 was used. A base year (2006) model validation (reasonableness check) was performed for the study area along US 41 from Kracker Avenue to Causeway Boulevard. Adjustments were made to the base year model to improve the accuracy levels of the model volumes. Details on subarea validation have been included in **Appendix F**. The process and results of subarea validation was coordinated and approved by FDOT - District 7 on April 8, 2013.

These subarea refinements including modifications to centroid connectors and facility types were applied to the future year 2035 model for the build scenario with 6 lanes along US 41 within project limits. Also, for the future year model, the 2035 socioeconomic (SE) data for the traffic analysis zones within the US 41 study area was compared to the SE data included in the socioeconomic analysis conducted by Renaissance Planning Group on behalf of the Tampa-Hillsborough County Expressway Authority (THEA). As the difference between the two data sets of the SE Data was not significant, no adjustments were made to the SE data for the adopted future year model. This was discussed and agreed upon with FDOT – District 7 on March 22, 2013. The documentation on SE data comparison has been included as a part of the subarea validation document in **Appendix F**.

Based on the results of the subarea validation, it was suggested by FDOT – District 7 that NCHRP 255 adjustment techniques (Ratio and Difference Method) be applied to the future year 2035 build model volumes along US 41 and along the following major side-streets - Causeway Boulevard, Madison Avenue, Riverview Drive, Gibsonton Drive, and Symmes Road. FDOT recommended use of a growth rate for the following minor side-streets - Hartford Street, Port Sutton Road, Nundy Avenue, Palm Avenue, Florence Street, Ohio Street and

Kracker Avenue and along minor approaches of major side-streets. The method of NCHRP 255 adjustments was applied to the 2035 build model volumes along US 41 and major side-streets within the project limits in order to establish the 2035 future model volumes to be used in forecasting along with the existing AADT. The NCHRP 255 adjustment and the model plots for the base year (2006) and future year (2035) are provided in **Appendix G**. The growth rates for the minor side-streets and for the minor approaches of the major side-streets were based on the comparison of the socioeconomic data between the base year (2006) and future year (2035) for the traffic analysis zones adjacent to these individual side-streets. Based on this approach, an annual growth rate of 3.04% was recommended for the minor side-streets and an annual growth rate of 1.81% was recommended for the minor approaches for the major side-streets. The calculations of these growth rates based on comparison of socioeconomic data and also, historical trend analyses have been included in **Appendix G**. The NCHRP 255 adjusted 2035 future build model volumes for US 41 and the major side-streets and the recommended growth rate for the minor side-streets and minor approaches of major side-streets were approved by FDOT – District 7 on April 8, 2013 and May 16, 2013.

#### *Development of Future Annual Average Daily Traffic (AADT)*

The opening year (2020), interim year (2030) and design year (2040) AADT were obtained by interpolation and extrapolation between the existing (2013) AADT and the established 2035 future build model volumes for the US 41 volumes and the major side-streets within the project limits. For the minor side-streets and the minor approaches of the major side-streets, future year AADT were calculated by applying a growth rate of 3.04% and 1.81% respectively on the existing (2013) AADT. The future year no-build and build AADT are shown in **Figure 4**.



#### *Development of Future AM and PM Peak Hour Traffic Volumes*

The future year AM and PM peak hour directional traffic volumes (DDHV) were obtained by multiplying the future year AADT volumes by the recommended K and D factors, respectively. These estimated DDHVs were then distributed at the study intersections by applying the existing turning percentages from the traffic counts listed in **Appendix D**. As in the existing year (2013), southbound is considered to be the peak direction along US 41 within the project limits during the PM peak period and northbound is considered to be the peak direction during

the AM peak period in the development of the peak hour turning volumes. Peak direction for each side-street was also calculated and included in **Appendix B**.

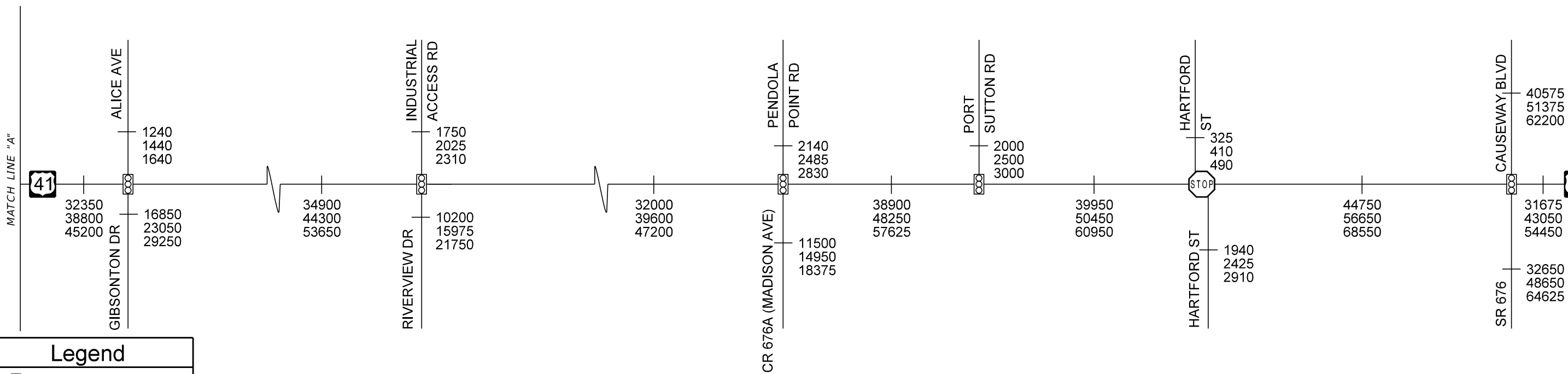
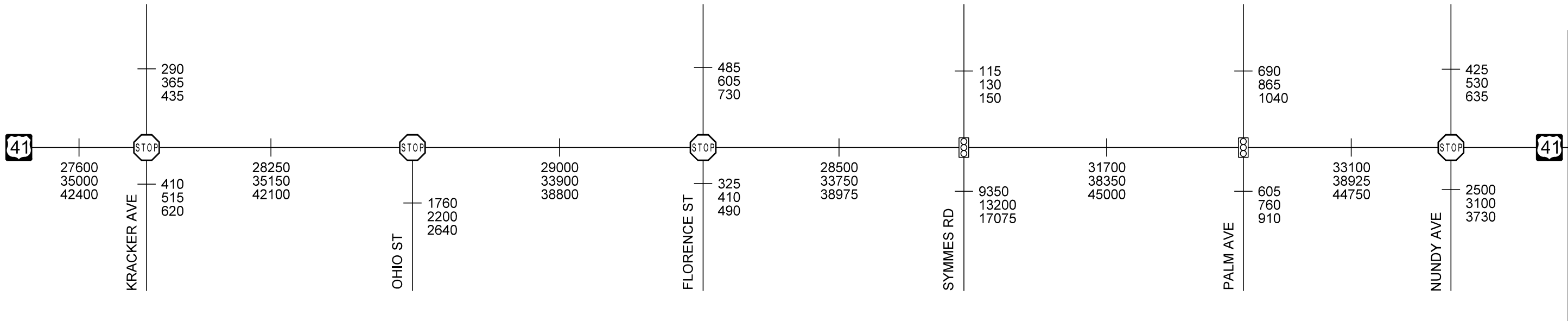
Calculation of the DDHV and the future AM and PM peak hour turning movements are provided in **Appendix H**. The spreadsheets illustrating the development of the AM and PM peak hour traffic volumes for the opening year, interim year and design year are included in **Appendix I**. The future no-build and build AM and PM peak hour volumes for the opening year (2020), interim year (2030) and design year (2040) are shown in **Figure 5, 6 and 7**, respectively.





Legend	
	TRAFFIC SIGNAL
	STOP SIGN (SIDE STREET ONLY)
1234	2020 AADTS
1234	2030 AADTS
1234	2040 AADTS

**US 41 PD&E Study**  
*From Kracker Avenue to South of SR 676 (Causeway Boulevard)*  
 WPI Number: 430056-1  
 Hillsborough County

**Future Year No-Build and Build Annual Average Daily Traffic (AADTS)**

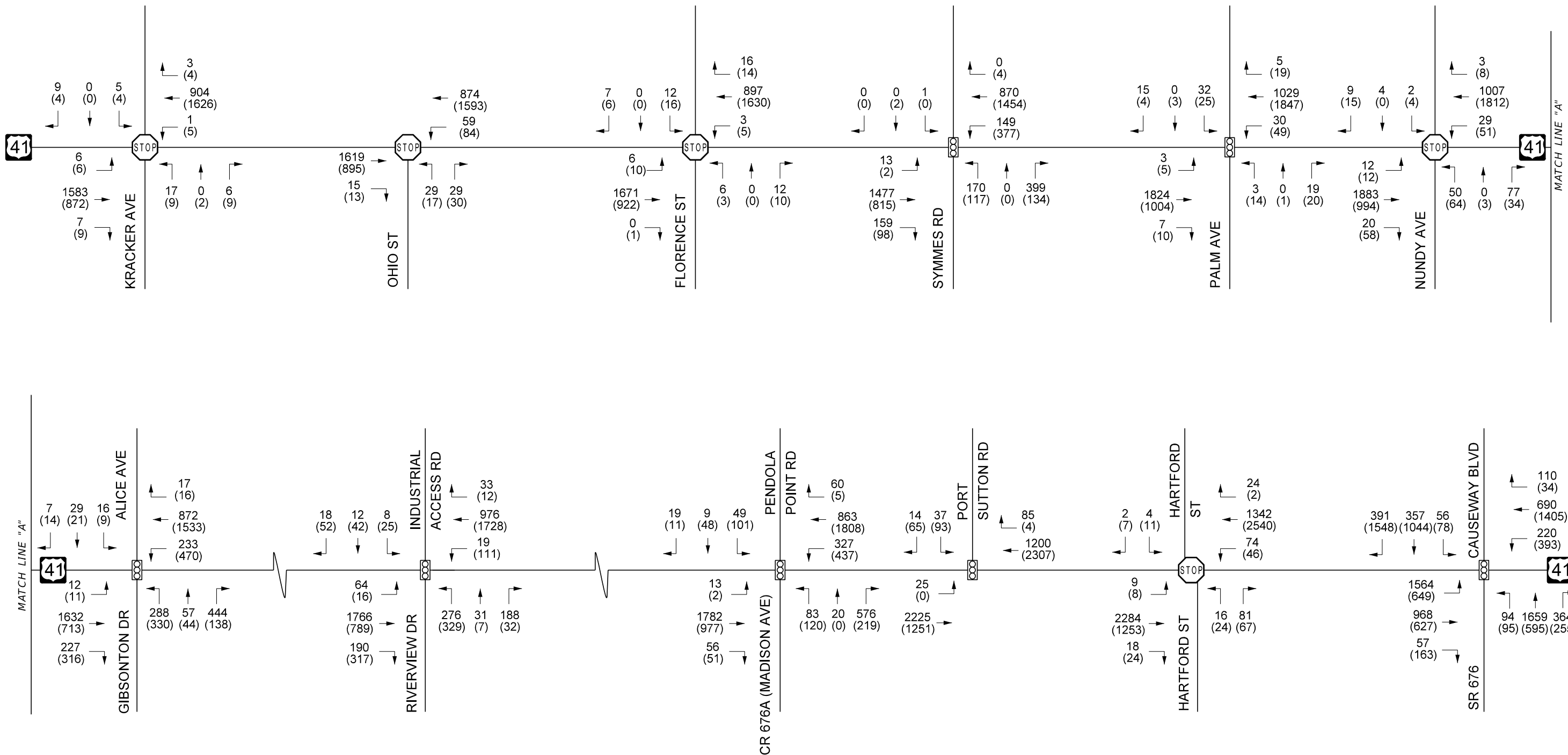
**Figure 4**





Legend	
	TRAFFIC SIGNAL
	STOP SIGN (SIDE STREET ONLY)
1234	AM PEAK HOUR VOLUME
(1234)	(PM PEAK HOUR VOLUME)

**US 41 PD&E Study**  
*From Kracker Avenue to South of SR 676 (Causeway Boulevard)*  
 WPI Number: 430056-1  
 Hillsborough County

Opening Year 2020 No-Build and Build AM and PM Peak Hour Traffic Volumes

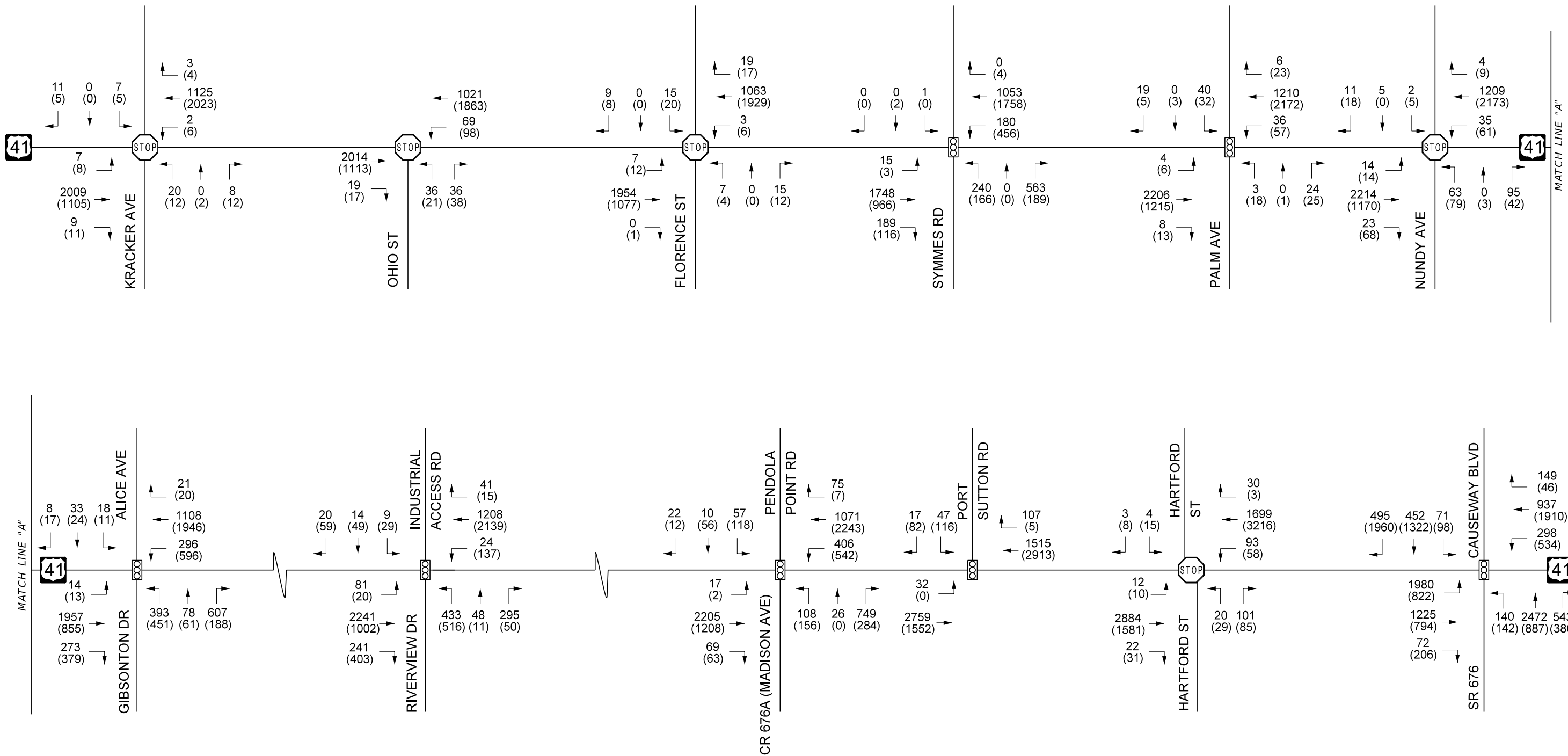
Figure 5



Legend	
	TRAFFIC SIGNAL
	STOP SIGN (SIDE STREET ONLY)
1234	AM PEAK HOUR VOLUME
(1234)	PM PEAK HOUR VOLUME



**US 41 PD&E Study**  
*From Kracker Avenue to South of SR 676 (Causeway Boulevard)*  
 WPI Number: 430056-1  
 Hillsborough County

Interim Year 2030 No-Build and Build AM and PM Peak Hour Traffic Volumes

Figure 6

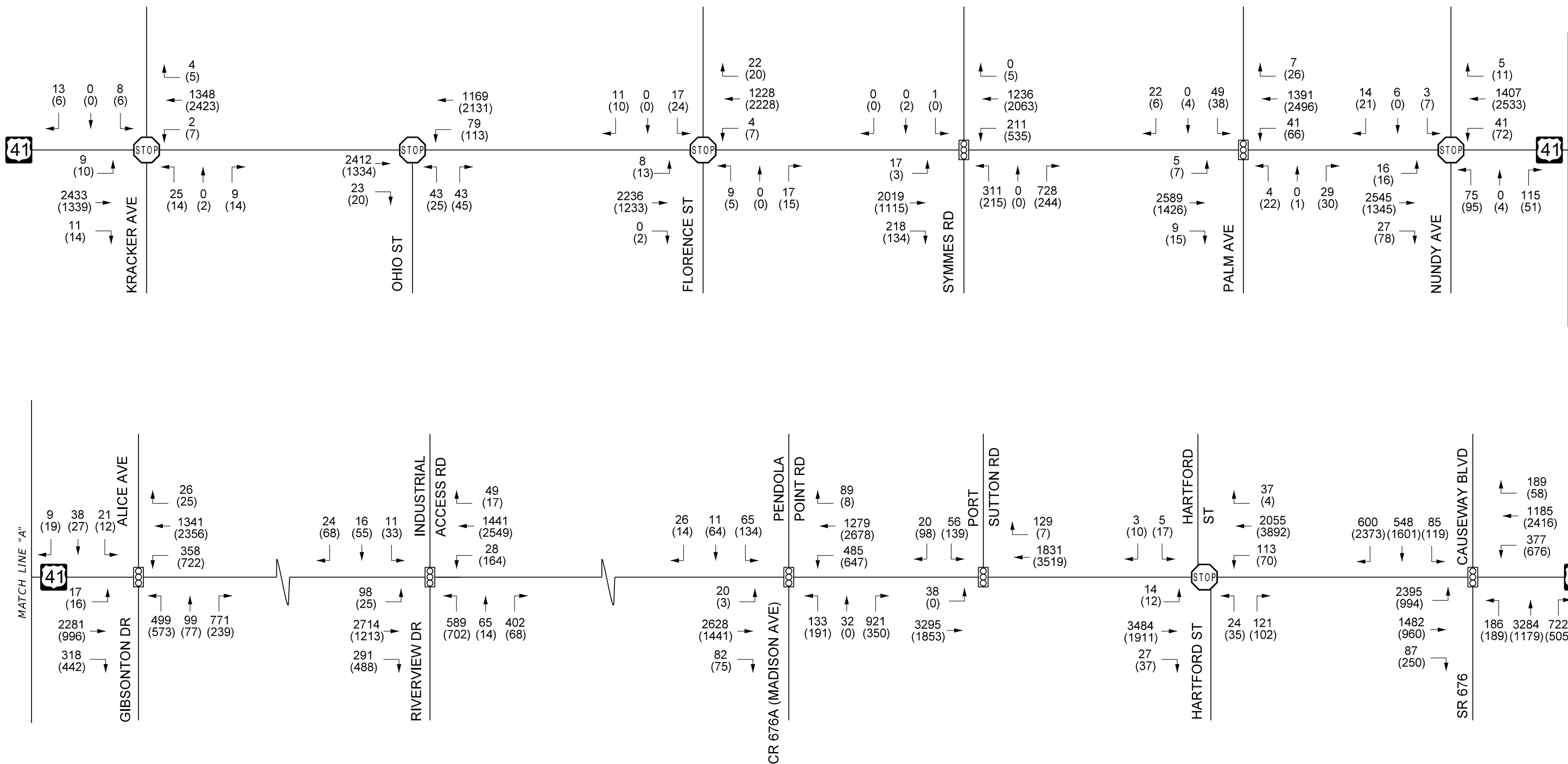



Legend	
	TRAFFIC SIGNAL
	STOP SIGN (SIDE STREET ONLY)
1234	AM PEAK HOUR VOLUME
(1234)	(PM PEAK HOUR VOLUME)

**US 41 PD&E Study**  
*From Kracker Avenue to South of SR 676 (Causeway Boulevard)*  
 WPI Number: 430056-1  
 Hillsborough County

Design Year 2040 No-Build and Build AM and PM Peak Hour Traffic Volumes

Figure 7

# **Appendix A**

## **Raw Traffic Counts (Included previously)**

**APPENDIX B**  
**DESIGN TRAFFIC FACTORS**  
**APPROVED TRAFFIC METHODOLOGY**  
**STATEMENT**

**Financial Project ID: 430056-1-22-01**

**US 41 PD&E - From Kracker Avenue to South of Causeway Boulevard**

**Recommended K-Factor:** 9.0% (Standard per 2012 Project Traffic Forecasting Handbook)

**Calculation of D-Factor for US 41**

Location along US 41	D-Factor*	D-Factor along US 41 within project limits from 2011 FTI DVD	Acceptable Range of D-Factor from 2012 Project Traffic Forecasting Handbook for Urban Principal Arterial	Recommended D-Factor
Between Kracker Avenue and Gibsonton Drive	66.00%	57.20%	50.8% - 67.1% (Median Value is 57.9%)	<b>64.27%</b> (Based on the average of the D-factor from the classification counts and that from FTI 2011 DVD)
Between Gibsonton Drive and Madison Avenue	77.00%			
Between Madison Avenue and Causeway Boulevard	71.00%			
Average	71.33%			

\* Based on 72-Hour Classification Counts Conducted

**Peak Direction:**

For PM - Southbound (SB) is the peak direction along US 41 between Kracker Avenue and Causeway Boulevard.

For AM - Northbound (NB) along US 41 (Reverse of PM) will be used.

## Traffic Count Data

Finance Number:  
 Location Code: 2  
 Count Location US 41 Between Kracker Avenue and Gibsonton Drive

TYPE OF COUNT: 72 Hour Class Classification Count

TIME OF COUNT:

Start Date:	1/8/2013	Start Time:	Midnight
End Date:	1/10/2013	End Time:	Midnight

VOLUMES:

Average Daily:	24,339	Peak Hour Start Time:	5:00 PM
Daily Truck Average:	2,072	Average Peak Hour:	2,230
		Max Hour Truck Average:	171
		Peak Hour Truck Average:	104

TRAVEL CHARACTERISTICS:

K MEASURED		D MEASURED	
K=	9%	D=	66%
T Max Hour	12%	T Daily	9%
T med (max)	5%	T med Daily	3%
T heavy (max)	7%	T heavy Daily	5%
T peak Hour	5%		
T med Peak Hour	3%	Axle Factor	0.95
T heavy Peak Hour	2%		

## Traffic Count Data

Finance Number:  
 Location Code:                   1  
 Count Location       US 41 Between Gibsonton Drive and Madison Avenue

TYPE OF COUNT:       72 Hour Class Classification Count

TIME OF COUNT:

Start Date:	1/8/2013	Start Time:	Midnight
End Date:	1/10/2013	End Time:	Midnight

VOLUMES:

	Average Daily:	23,942	Peak Hour Start Time:	5:00 PM
	Daily Truck Average:	2,266	Average Peak Hour:	2,359
			Max Hour Truck Average:	192
			Peak Hour Truck Average:	107

TRAVEL CHARACTERISTICS:

K MEASURED

D MEASURED

	K=	10%		D=	77%
	T Max Hour	18%		T Daily	9%
	T med (max)	6%		T med Daily	4%
	T heavy (max)	13%		T heavy Daily	6%
	T peak Hour	5%			
	T med Peak Hour	2%		Axle Factor	0.94
	T heavy Peak Hour	2%			

## Traffic Count Data

Finance Number:  
 Location Code: 1  
 Count Location US 41 Between Madison Avenue and Causeway Boulevard

TYPE OF COUNT: 72 Hour Class Classification Count

TIME OF COUNT:

Start Date:	1/8/2013	Start Time:	Midnight
End Date:	1/10/2013	End Time:	Midnight

VOLUMES:

	Average Daily:	34,659	Peak Hour Start Time:	5:00 PM
	Daily Truck Average:	3,651	Average Peak Hour:	3,168
			Max Hour Truck Average:	307
			Peak Hour Truck Average:	154

TRAVEL CHARACTERISTICS:

K MEASURED

D MEASURED

	K=	9%		D=	71%
	T Max Hour	19%		T Daily	11%
	T med (max)	4%		T med Daily	3%
	T heavy (max)	15%		T heavy Daily	8%
	T peak Hour	5%			
	T med Peak Hour	2%		Axle Factor	0.92
	T heavy Peak Hour	3%			

**US 41 PD&E - From Kracker Avenue to Causeway Boulevard**

**D-factor for Side-Streets**

Traffic Count Location	D for AM Peak	D for PM Peak	Peak Direction for AM	Peak Direction for PM
<b><i>Kracker Avenue</i></b>				
East of US 41	61.11%	54.17%	WB	WB
West of US 41	53.33%	69.23%	EB	WB
<b><i>Ohio Street</i></b>				
East of US 41	63.64%	70.43%	EB	EB
<b><i>Florence Street</i></b>				
East of US 41	60.00%	55.56%	WB	EB
West of US 41	56.67%	51.22%	WB	EB
<b><i>Symmes Road</i></b>				
East of US 41	67.60%	70.14%	WB	EB
West of US 41	91.67%	83.33%	WB	WB
<b><i>Palm Avenue</i></b>				
East of US 41	60.00%	64.47%	EB	WB
West of US 41	76.00%	51.06%	EB	EB
<b><i>Nundy Avenue</i></b>				
East of US 41	56.47%	55.42%	WB	EB
West of US 41	61.90%	51.43%	WB	WB
<b><i>Gibson Drive/Alice Avenue</i></b>				
East of US 41	52.02%	66.24%	WB	EB
West of US 41	54.12%	60.92%	WB	WB
<b><i>Riverview Drive/Industrial Access Road</i></b>				
East of US 41	53.94%	59.96%	WB	EB
West of US 41	75.65%	75.25%	WB	EB
<b><i>Madison Avenue/Pendola Point Road</i></b>				
East of US 41	65.65%	67.28%	WB	EB
West of US 41	60.00%	83.33%	WB	EB
<b><i>Port Sutton Road</i></b>				
West of US 41	71.74%	87.88%	WB	EB
<b><i>Hartford Street</i></b>				
East of US 41	55.47%	52.25%	WB	WB
West of US 41	80.77%	61.11%	WB	EB
<b><i>Causeway Boulevard</i></b>				
East of US 41	72.06%	67.79%	WB	EB
West of US 41	77.98%	73.11%	WB	EB

Source - From Existing Turning Movement Counts conducted.



US 41 PD&E - From Kracker Avenue to South of Causeway Boulevard

Calculation of Truck Percentages for Side Streets along US 41 within Project Limits

Side-Street along US 41	Design Hour Truck (DHT)*			
	AM		PM	
	EB	WB	EB	WB
Kracker Avenue	0.0%	0.0%	0.0%	15.4%
Ohio Street	-	15.7%	-	0.0%
Florence Street	0.0%	0.0%	0.0%	0.0%
Symmes Road	0.0%	5.6%	0.0%	3.6%
Palm Avenue	0.0%	0.0%	4.2%	0.0%
Nundy Avenue	0.0%	10.4%	0.0%	2.8%
Gibson Drive/Alice Avenue	0.0%	5.9%	5.9%	4.6%
Riverview Drive/Industrial Access Road	14.3%	5.7%	1.3%	2.3%
Madison Avenue/Pendola Point Road	55.6%	9.7%	14.3%	8.9%
Port Sutton Road	42.3%	-	0.0%	-
Hartford Street	0.0%	27.1%	10.0%	13.3%
Causeway Boulevard	16.9%	5.3%	3.5%	6.3%

\*All the DHT will be rounded to the nearest integer.

Source: Existing AM and PM peak hour turning movement counts.



2.6.2.1 STANDARD K FACTORS



FDOT has decided to replace the K<sub>30</sub> factors with Standard K factors. This has occurred because it has been widely recognized that roadways in urbanized areas cannot be cost effectively designed based on the 30<sup>th</sup> highest hour demand volumes. Another issue that impacts the use of the K factors is the relationship between demand traffic volumes and measured traffic volumes.

Standard K factors have been established statewide by using the data measured at the continuous count sites. The Standard K factors are based on area type and facility type with consideration to typical peak periods of the day.

For example, on freeways throughout the seven largest urbanized areas in Florida, the peak analysis period is used. For other facilities, the use of a typical peak hour is generally used. Standard K Factors for design analyses are not directly applicable for the Turnpike, other toll roads, and managed lanes. The recommended Standard K factors are reflected in the following Figure 2.4.

FDOT Standard K Factors			
Area <i>(Population) [Examples]</i>	Facility Type	Standard K Factors* <i>(%AADT)</i>	Representative Time Period
Large Urbanized Areas with Core Freeways <i>(1,000,000+) [Jacksonville, Miami]</i>	Freeways	8.0 - 9.0 ***	Typical weekday peak period or hour
	Arterials & Highways	9.0**	Typical weekday peak hour
Other Urbanized Areas <i>(50,000+) [Tallahassee, Ft. Myers]</i>	Freeways	9.0 **	Typical weekday peak hour
	Arterials & Highways	9.0 **	Typical weekday peak hour
Transitioning to Urbanized Areas <i>(Uncertain) [Fringe Development Areas]</i>	Freeways	9.0	Typical weekday peak hour
	Arterials & Highways	9.0	Typical weekday peak hour
Urban <i>(5,000-50,000) [Lake City, Key West]</i>	Freeways	10.5	100th highest hour of the year
	Arterials & Highways	9.0 **	Typical weekday peak hour
Rural <i>(&lt;5,000) [Chipley, Everglades]</i>	Freeways	10.5	100th highest hour of the year
	Arterials	9.5 **	100th highest hour of the year
	Highways	9.5	100th highest hour of the year
	* Some smoothing of values at area boundaries/edges would be desirable.		
	** Value is 7.5% in approved Multimodal Transportation Districts where automobile movements are deemphasized. Essentially, this lower value represents an extensive multi-hour peak period rather than a peak hour.		
	*** Value is 8.0% for FDOT-designated urbanized core freeways and may be either be 8.5% or 9.0% for non-core freeways. Values less than 9% essentially represent a multi-hour peak period rather than a peak hour.		

Figure 2.4 FDOT Standard K Factors



**2.6.3.3 Acceptable D Values**

The directional distribution factor, D is based on the median (or average) for the 200th Highest Hour Traffic Count Report and referred to as D, derived from the permanent count stations. The D values are also available from FDOT’s RCI and TCI databases. If traffic counts for the project site are not available, obtain 24-hour (urban) or 48-hour (rural) classification counts to determine hourly traffic volume distribution. This will allow the identification of the peak hour of the day and peak direction during the peak hour.

To determine if a D value is acceptable for a project traffic forecasting projection, the following three steps are necessary:

- Step 1. First determine if a D value is within an acceptable range of demand D values, using Figure 2.9.

	Road Type	Low	D	High	Standard Deviation
	Rural Freeway	52.3	54.8	57.3	1.73
	Rural Arterial	51.1	58.1	79.6	6.29
	Urban Freeway	50.4	55.8	61.2	4.11
	Urban Arterial	50.8	57.9	67.1	4.60

**Figure 2.9 Recommended D-Factors (D) for Traffic Forecasting**

- Step 2. The user should use the 200th Highest Hour Traffic Count Report for establishing D for unconstrained sites.
- Step 3. If the site is “constrained,” **Demand D** should be used. Demand D is estimated based on the 200<sup>th</sup> Highest Hour Traffic Count Report using traffic data for unconstrained sites with similar roadway characteristics. Select the appropriate D value by analyzing the traffic characteristics and comparing them with unconstrained traffic counts locations.

**2.6.3.4 Adjusting the D Factor**

On highways with more than two lanes and on two-lane roads where important intersections are encountered or where additional lanes are to be provided later, knowledge of the hourly traffic volume in each direction of travel is essential for design.

## MEMORANDUM

**Date:** January 17, 2013  
**To:** Waddah Farah, Florida Department of Transportation (FDOT), District Seven  
**From:** Akram Hussein, PE, PTOE  
**Cc:** Rick Adair (FDOT PD&E Project Manager); Peter Maass PE, PTOE, David Winkle, Jeff Novotny, PE, AICP; Larry Weatherby, PE; David Bredahl, AICP, Arpita Guha, PE  
**Subject:** Traffic Methodology Statement for:  
**US 41 PD&E Study from Kracker Avenue to South of SR 676 (Causeway Boulevard) FPID: 430056-1-22-01**  
**American Project No: 5127041**

1. Traffic data collection including 72-hour vehicle classification counts, 72-hour bi-directional counts at intersection approaches and 4-hour turning movement counts at the study intersections will be conducted in January 2013 as shown below:
  - A. 72-hour vehicle classification counts (bi-directional approach volumes) at the following locations:
    - (1) US 41 between Kracker Avenue and Gibsonton Drive
    - (2) US 41 between Gibsonton Drive and CR 676A (Madison Avenue)
    - (3) US 41 between CR 676A (Madison Avenue) and south of CR 676 (Causeway Boulevard)
  - B. 72-hour machine counts (bi-directional approach volumes) and at the same time, perform 4-hour manual (2 hours AM and 2 hours PM) vehicle turning movement counts for peak hours at the following intersections:
    - (1) Kracker Avenue (unsignalized)
    - (2) Ohio Street (unsignalized)
    - (3) Florence Street (unsignalized)
    - (4) Symmes Road (signalized)
    - (5) Palm Avenue (signalized)
    - (6) Nundy Avenue (unsignalized)
    - (7) Gibsonton Drive (signalized)
    - (8) Riverview Drive (signalized)\*

- (9) CR 676A (Madison Avenue) – signalized\*
  - (10) Port Sutton Road (signalized)\*
  - (11) Hartford Street (unsignalized)
  - (12) CR 676 (Causeway Boulevard) – signalized
2. Intersections with \* provide a direct connection to Port of Tampa facilities. These approaches will be further evaluated for time periods that are outside the typical morning (7-9 a.m.) and afternoon (4-6 p.m.) peak periods. This evaluation would require reviewing the 72-hour traffic count data to identify alternative time periods that truck traffic may be prevalent and could possibly impact operations of the subject intersection. The sizing of turn lanes at these intersections will be performed in a manner that allows for the accommodation of high-volume truck movements made throughout an average day.
  3. The project will use the standard K factor of 9% for this area. Recommendations will be made for the D-factor and the truck percentages to be used for this study. A memorandum on the recommended design traffic factors will be submitted to FDOT for review and approval.
  4. Existing year 2013 design hour traffic volumes will be developed by applying the recommended K and D factors to the annual average daily traffic (AADT) on the intersection approaches to determine the directional design hour volumes (DDHV) and then distributing the DDHV in the proportion of the existing turning traffic at the intersections to derive the design hour volumes.
  5. K and D factors along with existing turning percentages will be used for the development of the existing and the future design hour volumes. The TURNS program will not be used.
  6. The Tampa Bay Regional Planning (TBRPM) Base year (2006) model will be checked for reasonableness and if necessary for accuracy, adjustments will be made as needed.
  7. The opening year will be 2020, the design year will be 2040 and the interim year will be 2030.
  8. 2035 model traffic projections will be extrapolated to derive 2040 AADTs.
  9. The opening (2020), interim (2030) and design year (2040) AADTs will be developed through interpolation/extrapolation in between the existing year (2013) AADT volumes and 2035 Build Model traffic volumes.
  10. Future design hour traffic volumes will be developed by applying the recommended K and D factors to the annual average daily traffic (AADT) on the intersection approaches to determine the directional design hour volumes (DDHV) and then distributing the DDHV in the proportion of the existing turning traffic at the intersections to derive the future design hour volumes.
  11. The traffic volumes will not be balanced exactly from one intersection departure to the next intersection approach. Reasonableness checks will be done based on access (driveways) and land uses that occur between intersections.

12. The future AADTs and therefore, the AM and PM design hour volumes for the no-build and the build conditions will be considered to be the same.
13. All existing and future traffic volumes will be reviewed and approved by FDOT.
14. AM and PM design hour volumes will both be developed to insure adequate lane geometry.
15. Existing, No-Build and Build intersection and roadway segment analysis will be conducted using SYNCHRO 7 and HCS+ Version 5.5. Output from SYNCHRO 7 will be using the HCM methodology.
16. Future analysis of No Build and Build conditions will be conducted for years 2020, 2030, and 2040.
17. Queue length analysis will be conducted for the design year 2040 AM and PM peak hours for build conditions.
18. Arterial analysis will be conducted using SYNCHRO 7 within the intersections shown in number 1. Arterial analysis will only include intersections within the study limits. Output from SYNCHRO 7 will be using the HCM methodology.
19. For the un-signalized locations, signal warrants 1 & 2 will be tested if that location needs to be signalized in the future to meet the acceptable LOS.
20. As the study area is urbanized, acceptable LOS will be considered to be "D" along the study corridor within the project limits based on the Planning Boundaries for LOS Standards for Hillsborough County and Table 8-1 of the 2009 FDOT Quality/Level of Service Handbook.

## **APPENDIX C**

### **AADTS AND ADJUSTMENT FACTORS**

**US 41 PD&E - From Kracker Avenue to Causeway Boulevard**

**Calculation of AADTs from Approach Counts**

Traffic Count Location	Date of Count	Year 2013 ADTCount	Seasonal Factor <sup>(1)</sup>	Axle Factor <sup>(1)</sup>	2013 AADT	Rounded 2012 AADT
<b>US 41</b>						
South of Kracker Avenue	1/16/2013	23312	0.99	0.97	22387	22400
North of Kracker Avenue	1/9/2013	23099	1.00	0.97	22406	22400
South of Ohio Street	1/8/2013	23865	1.01	0.97	23381	<b>23400</b>
North of Ohio Street	1/8/2013	24616	1.01	0.97	24116	24100
South of Florence Street	1/9/2013	26319	1.00	0.97	25529	<b>25550</b>
North of Florence Street	1/9/2013	25637	1.00	0.97	24868	<b>24850</b>
South of Symmes Road	1/9/2013	25539	1.00	0.97	24773	24750
North of Symmes Road	1/9/2013	27759	1.00	0.97	26926	26950
South of Palm Avenue	1/9/2013	27886	1.00	0.97	27049	<b>27050</b>
North of Palm Avenue	1/9/2013	29935	1.00	0.97	29037	<b>29050</b>
South of Nundy Avenue	1/10/2013	29516	1.00	0.97	28631	28650
North of Nundy Avenue	1/10/2013	28696	1.00	0.97	27835	<b>27850</b>
South of Gibsonton Drive	1/9/2013	28062	1.00	0.97	27220	27200
North of Gibsonton Drive	1/9/2013	27660	1.00	0.97	26830	26850
South of Riverview Drive	1/8/2013	28958	1.01	0.97	28370	<b>28350</b>
North of Riverview Drive	1/16/2013	25062	0.99	0.97	24067	24050
South of Madison Avenue	1/9/2013	27485	1.00	0.97	26660	<b>26650</b>
North of Madison Avenue	1/9/2013	33360	1.00	0.97	32359	32350
South of Port Sutton Road	1/9/2013	33360	1.00	0.97	32359	<b>32350</b>
North of Port Sutton Road	1/10/2013	32782	1.00	0.97	31799	31800
South of Hartford Street	1/30/2013	35026	0.96	0.97	32616	<b>32600</b>
North of Hartford Street	1/8/2013	35084	1.01	0.97	34372	34350
South of Causeway Boulevard	1/10/2013	37515	1.00	0.97	36390	<b>36400</b>
North of Causeway Boulevard	1/17/2013	24699	0.99	0.97	23718	23700
<b>Kracker Avenue</b>						
East of US 41	1/8/2013	352	1.01	0.95	338	340
West of US 41	1/9/2013	250	1.00	0.95	238	240
<b>Ohio Street</b>						
East of US 41	1/8/2013	1490	1.01	0.95	1430	1450
<b>Florence Street</b>						
East of US 41	1/9/2013	285	1.00	0.95	271	270
West of US 41	1/8/2013	421	1.01	0.95	404	400
<b>Symmes Road</b>						
East of US 41	1/9/2013	6994	1.00	0.95	6644	6650
West of US 41 <sup>(2)</sup>	-	100	-	-	100	100
<b>Palm Avenue</b>						
East of US 41 <sup>(2)</sup>	-	500	-	-	500	500
West of US 41	1/10/2013	600	1.00	0.95	570	570
<b>Nundy Avenue</b>						
East of US 41	1/9/2013	2151	1.00	0.95	2043	2050
West of US 41	1/30/2013	386	0.96	0.95	352	350
<b>Gibsonton Drive/Alice Avenue</b>						
East of US 41	1/9/2013	13176	1.00	0.95	12517	12500
West of US 41	1/9/2013	1166	1.00	0.95	1108	1100
<b>Riverview Drive/Industrial Access Road</b>						
East of US 41	1/10/2013	6455	1.00	0.95	6132	6150
West of US 41	1/10/2013	1609	1.00	0.95	1529	1550
<b>Madison Avenue/Pendola Point Road</b>						
East of US 41	1/10/2013	9596	1.00	0.95	9116	9100
West of US 41	1/10/2013	2014	1.00	0.95	1913	1900
<b>Port Sutton Road</b>						
West of US 41	1/10/2013	1726	1.00	0.95	1640	1650
<b>Hartford Street</b>						
East of US 41	1/16/2013	1704	0.99	0.95	1603	1600
West of US 41	1/29/2013	295	0.97	0.95	272	270
<b>Causeway Boulevard</b>						
East of US 41	1/9/2013	22579	1.00	0.95	21450	21450
West of US 41	1/9/2013	34720	1.00	0.95	32984	33000

(1) Source: 2011 Florida Traffic Information DVD

Segments with more than one AADT, the one used is in **BOLD**

(2) AADT assumed as counts were not conducted on these minor approaches



2011 Peak Season Factor Category Report - Report Type: ALL  
 Category: 1000 HILLSBOROUGH COUNTYWIDE

MOCF: 0.94

Week	Dates	SF	PSCF
1	01/01/2011 - 01/01/2011	1.02	1.08
2	01/02/2011 - 01/08/2011	1.01	1.07
3	01/09/2011 - 01/15/2011	1.00	1.06
4	01/16/2011 - 01/22/2011	0.99	1.05
* 5	01/23/2011 - 01/29/2011	0.97	1.03
* 6	01/30/2011 - 02/05/2011	0.96	1.02
* 7	02/06/2011 - 02/12/2011	0.94	1.00
* 8	02/13/2011 - 02/19/2011	0.93	0.99
* 9	02/20/2011 - 02/26/2011	0.93	0.99
*10	02/27/2011 - 03/05/2011	0.92	0.98
*11	03/06/2011 - 03/12/2011	0.92	0.98
*12	03/13/2011 - 03/19/2011	0.92	0.98
*13	03/20/2011 - 03/26/2011	0.93	0.99
*14	03/27/2011 - 04/02/2011	0.94	1.00
*15	04/03/2011 - 04/09/2011	0.95	1.01
*16	04/10/2011 - 04/16/2011	0.96	1.02
*17	04/17/2011 - 04/23/2011	0.97	1.03
18	04/24/2011 - 04/30/2011	0.98	1.04
19	05/01/2011 - 05/07/2011	0.99	1.05
20	05/08/2011 - 05/14/2011	1.00	1.06
21	05/15/2011 - 05/21/2011	1.01	1.07
22	05/22/2011 - 05/28/2011	1.01	1.07
23	05/29/2011 - 06/04/2011	1.02	1.08
24	06/05/2011 - 06/11/2011	1.02	1.08
25	06/12/2011 - 06/18/2011	1.02	1.08
26	06/19/2011 - 06/25/2011	1.03	1.09
27	06/26/2011 - 07/02/2011	1.04	1.10
28	07/03/2011 - 07/09/2011	1.04	1.10
29	07/10/2011 - 07/16/2011	1.05	1.12
30	07/17/2011 - 07/23/2011	1.05	1.12
31	07/24/2011 - 07/30/2011	1.05	1.12
32	07/31/2011 - 08/06/2011	1.04	1.10
33	08/07/2011 - 08/13/2011	1.04	1.10
34	08/14/2011 - 08/20/2011	1.04	1.10
35	08/21/2011 - 08/27/2011	1.04	1.10
36	08/28/2011 - 09/03/2011	1.04	1.10
37	09/04/2011 - 09/10/2011	1.04	1.10
38	09/11/2011 - 09/17/2011	1.04	1.10
39	09/18/2011 - 09/24/2011	1.03	1.09
40	09/25/2011 - 10/01/2011	1.02	1.08
41	10/02/2011 - 10/08/2011	1.02	1.08
42	10/09/2011 - 10/15/2011	1.01	1.07
43	10/16/2011 - 10/22/2011	1.01	1.07
44	10/23/2011 - 10/29/2011	1.01	1.07
45	10/30/2011 - 11/05/2011	1.02	1.08
46	11/06/2011 - 11/12/2011	1.02	1.08
47	11/13/2011 - 11/19/2011	1.02	1.08
48	11/20/2011 - 11/26/2011	1.02	1.08
49	11/27/2011 - 12/03/2011	1.02	1.08
50	12/04/2011 - 12/10/2011	1.02	1.08
51	12/11/2011 - 12/17/2011	1.02	1.08
52	12/18/2011 - 12/24/2011	1.01	1.07
53	12/25/2011 - 12/31/2011	1.00	1.06

\* Peak Season

County: 10 - HILLSBOROUGH

Week	Dates	1010	1011	US41	1012	1013
		SR618, SR600 - SR60	SR618, SR60 - I75			US301, MANATEE-CR672
1	01/01/2011 - 01/01/2011	0.95	0.97		0.97	0.96
2	01/02/2011 - 01/08/2011	0.95	0.97		0.97	0.96
3	01/09/2011 - 01/15/2011	0.95	0.97		0.97	0.96
4	01/16/2011 - 01/22/2011	0.95	0.97		0.97	0.96
5	01/23/2011 - 01/29/2011	0.95	0.97		0.97	0.96
6	01/30/2011 - 02/05/2011	0.95	0.97		0.97	0.96
7	02/06/2011 - 02/12/2011	0.95	0.97		0.97	0.96
8	02/13/2011 - 02/19/2011	0.95	0.97		0.97	0.96
9	02/20/2011 - 02/26/2011	0.95	0.97		0.97	0.96
10	02/27/2011 - 03/05/2011	0.95	0.97		0.97	0.96
11	03/06/2011 - 03/12/2011	0.95	0.97		0.97	0.96
12	03/13/2011 - 03/19/2011	0.95	0.97		0.97	0.96
13	03/20/2011 - 03/26/2011	0.95	0.97		0.97	0.96
14	03/27/2011 - 04/02/2011	0.95	0.97		0.97	0.96
15	04/03/2011 - 04/09/2011	0.95	0.97		0.97	0.96
16	04/10/2011 - 04/16/2011	0.95	0.97		0.97	0.96
17	04/17/2011 - 04/23/2011	0.95	0.97		0.97	0.96
18	04/24/2011 - 04/30/2011	0.95	0.97		0.97	0.96
19	05/01/2011 - 05/07/2011	0.95	0.97		0.97	0.96
20	05/08/2011 - 05/14/2011	0.95	0.97		0.97	0.96
21	05/15/2011 - 05/21/2011	0.95	0.97		0.97	0.96
22	05/22/2011 - 05/28/2011	0.95	0.97		0.97	0.96
23	05/29/2011 - 06/04/2011	0.95	0.97		0.97	0.96
24	06/05/2011 - 06/11/2011	0.95	0.97		0.97	0.96
25	06/12/2011 - 06/18/2011	0.95	0.97		0.97	0.96
26	06/19/2011 - 06/25/2011	0.95	0.97		0.97	0.96
27	06/26/2011 - 07/02/2011	0.95	0.97		0.97	0.96
28	07/03/2011 - 07/09/2011	0.95	0.97		0.97	0.96
29	07/10/2011 - 07/16/2011	0.95	0.97		0.97	0.96
30	07/17/2011 - 07/23/2011	0.95	0.97		0.97	0.96
31	07/24/2011 - 07/30/2011	0.95	0.97		0.97	0.96
32	07/31/2011 - 08/06/2011	0.95	0.97		0.97	0.96
33	08/07/2011 - 08/13/2011	0.95	0.97		0.97	0.96
34	08/14/2011 - 08/20/2011	0.95	0.97		0.97	0.96
35	08/21/2011 - 08/27/2011	0.95	0.97		0.97	0.96
36	08/28/2011 - 09/03/2011	0.95	0.97		0.97	0.96
37	09/04/2011 - 09/10/2011	0.95	0.97		0.97	0.96
38	09/11/2011 - 09/17/2011	0.95	0.97		0.97	0.96
39	09/18/2011 - 09/24/2011	0.95	0.97		0.97	0.96
40	09/25/2011 - 10/01/2011	0.95	0.97		0.97	0.96
41	10/02/2011 - 10/08/2011	0.95	0.97		0.97	0.96
42	10/09/2011 - 10/15/2011	0.95	0.97		0.97	0.96
43	10/16/2011 - 10/22/2011	0.95	0.97		0.97	0.96
44	10/23/2011 - 10/29/2011	0.95	0.97		0.97	0.96
45	10/30/2011 - 11/05/2011	0.95	0.97		0.97	0.96
46	11/06/2011 - 11/12/2011	0.95	0.97		0.97	0.96
47	11/13/2011 - 11/19/2011	0.95	0.97		0.97	0.96
48	11/20/2011 - 11/26/2011	0.95	0.97		0.97	0.96
49	11/27/2011 - 12/03/2011	0.95	0.97		0.97	0.96
50	12/04/2011 - 12/10/2011	0.95	0.97		0.97	0.96
51	12/11/2011 - 12/17/2011	0.95	0.97		0.97	0.96
52	12/18/2011 - 12/24/2011	0.95	0.97		0.97	0.96
53	12/25/2011 - 12/31/2011	0.95	0.97		0.97	0.96

County: 10 - HILLSBOROUGH

Week	Dates	1000	1001	1002	1003
		HILLSBOROUGH - COUNTY WID	HILLSBOROUGH RURAL	HILLSBOROUGH URBAN	I75, MANATEE-US301
1	01/01/2011 - 01/01/2011	0.96	0.85	0.95	0.91
2	01/02/2011 - 01/08/2011	0.96	0.85	0.95	0.91
3	01/09/2011 - 01/15/2011	0.96	0.85	0.95	0.91
4	01/16/2011 - 01/22/2011	0.96	0.85	0.95	0.91
5	01/23/2011 - 01/29/2011	0.96	0.85	0.95	0.91
6	01/30/2011 - 02/05/2011	0.96	0.85	0.95	0.91
7	02/06/2011 - 02/12/2011	0.95	0.85	0.95	0.91
8	02/13/2011 - 02/19/2011	0.95	0.85	0.95	0.91
9	02/20/2011 - 02/26/2011	0.95	0.85	0.95	0.91
10	02/27/2011 - 03/05/2011	0.95	0.85	0.95	0.91
11	03/06/2011 - 03/12/2011	0.95	0.85	0.95	0.91
12	03/13/2011 - 03/19/2011	0.95	0.85	0.95	0.91
13	03/20/2011 - 03/26/2011	0.95	0.85	0.95	0.91
14	03/27/2011 - 04/02/2011	0.95	0.85	0.95	0.91
15	04/03/2011 - 04/09/2011	0.95	0.85	0.95	0.91
16	04/10/2011 - 04/16/2011	0.95	0.85	0.95	0.91
17	04/17/2011 - 04/23/2011	0.95	0.85	0.95	0.91
18	04/24/2011 - 04/30/2011	0.95	0.85	0.95	0.91
19	05/01/2011 - 05/07/2011	0.95	0.85	0.95	0.91
20	05/08/2011 - 05/14/2011	0.95	0.85	0.95	0.91
21	05/15/2011 - 05/21/2011	0.96	0.85	0.95	0.91
22	05/22/2011 - 05/28/2011	0.95	0.85	0.95	0.91
23	05/29/2011 - 06/04/2011	0.95	0.85	0.95	0.91
24	06/05/2011 - 06/11/2011	0.95	0.85	0.95	0.91
25	06/12/2011 - 06/18/2011	0.95	0.85	0.95	0.91
26	06/19/2011 - 06/25/2011	0.95	0.85	0.95	0.91
27	06/26/2011 - 07/02/2011	0.95	0.85	0.95	0.91
28	07/03/2011 - 07/09/2011	0.95	0.85	0.95	0.91
29	07/10/2011 - 07/16/2011	0.96	0.85	0.95	0.91
30	07/17/2011 - 07/23/2011	0.95	0.85	0.95	0.91
31	07/24/2011 - 07/30/2011	0.95	0.85	0.95	0.91
32	07/31/2011 - 08/06/2011	0.95	0.85	0.95	0.91
33	08/07/2011 - 08/13/2011	0.95	0.85	0.95	0.91
34	08/14/2011 - 08/20/2011	0.95	0.85	0.95	0.91
35	08/21/2011 - 08/27/2011	0.95	0.85	0.95	0.91
36	08/28/2011 - 09/03/2011	0.96	0.85	0.95	0.91
37	09/04/2011 - 09/10/2011	0.96	0.85	0.95	0.91
38	09/11/2011 - 09/17/2011	0.96	0.85	0.95	0.91
39	09/18/2011 - 09/24/2011	0.96	0.85	0.95	0.91
40	09/25/2011 - 10/01/2011	0.96	0.85	0.95	0.91
41	10/02/2011 - 10/08/2011	0.96	0.85	0.95	0.91
42	10/09/2011 - 10/15/2011	0.96	0.85	0.95	0.91
43	10/16/2011 - 10/22/2011	0.96	0.85	0.95	0.91
44	10/23/2011 - 10/29/2011	0.96	0.85	0.95	0.91
45	10/30/2011 - 11/05/2011	0.96	0.85	0.95	0.91
46	11/06/2011 - 11/12/2011	0.96	0.85	0.95	0.91
47	11/13/2011 - 11/19/2011	0.96	0.85	0.95	0.91
48	11/20/2011 - 11/26/2011	0.96	0.85	0.95	0.91
49	11/27/2011 - 12/03/2011	0.96	0.85	0.95	0.91
50	12/04/2011 - 12/10/2011	0.96	0.85	0.95	0.91
51	12/11/2011 - 12/17/2011	0.96	0.85	0.95	0.91
52	12/18/2011 - 12/24/2011	0.96	0.85	0.95	0.91
53	12/25/2011 - 12/31/2011	0.96	0.85	0.95	0.91

## **APPENDIX D**

# **CALCULATION OF DIRECTIONAL DESIGN HOUR VOLUMES AND AM AND PM TURNING TRAFFIC VOLUMES**

**US 41 PD&E - From Kracker Avenue to Causeway Boulevard**

**Calculation of DDHVs from AADTs - AM Peak**

Traffic Count Location	2013 AADT	K	D-Peak	D-Off Peak	Peak DDHV	Off Peak DDHV
<b>US 41</b>						
South of Kracker Avenue	22400	9.00%	64.27%	35.73%	1296	720
Kracker Avenue - Ohio Street	23400	9.00%	64.27%	35.73%	1354	752
Ohio Street - Florence Street	25550	9.00%	64.27%	35.73%	1478	822
Florence Street - Symmes Road	24850	9.00%	64.27%	35.73%	1437	799
Symmes Road - Palm Avenue	27050	9.00%	64.27%	35.73%	1565	870
Palm Avenue - Nundy Avenue	29050	9.00%	64.27%	35.73%	1680	934
Nundy Avenue - Gibsonton Drive	27850	9.00%	64.27%	35.73%	1611	896
Gibsonton Drive - Riverview Drive	28350	9.00%	64.27%	35.73%	1640	912
Riverview Drive - Madison Avenue	26650	9.00%	64.27%	35.73%	1542	857
Madison Avenue - Port Sutton Road	32350	9.00%	64.27%	35.73%	1871	1040
Port Sutton Road - Hartford Street	32600	9.00%	64.27%	35.73%	1886	1048
Hartford Street - Causeway Boulevard	36400	9.00%	64.27%	35.73%	2105	1171
North of Causeway Boulevard	23700	9.00%	64.27%	35.73%	1371	762
<b>Kracker Avenue</b>						
East of US 41	340	9.00%	61.11%	38.89%	19	12
West of US 41	240	9.00%	53.33%	46.67%	12	10
<b>Ohio Street</b>						
East of US 41	1450	9.00%	63.64%	36.36%	83	47
<b>Florence Street</b>						
East of US 41	270	9.00%	60.00%	40.00%	15	10
West of US 41	400	9.00%	56.67%	43.33%	20	16
<b>Symmes Road</b>						
East of US 41	6650	9.00%	67.60%	32.40%	405	194
West of US 41	100	9.00%	91.67%	8.33%	8	1
<b>Palm Avenue</b>						
East of US 41	500	9.00%	60.00%	40.00%	27	18
West of US 41	570	9.00%	76.00%	24.00%	39	12
<b>Nundy Avenue</b>						
East of US 41	2050	9.00%	56.47%	43.53%	104	80
West of US 41	350	9.00%	61.90%	38.10%	19	12
<b>Gibsonton Drive/Alice Avenue</b>						
East of US 41	12500	9.00%	52.02%	47.98%	585	540
West of US 41	1100	9.00%	54.12%	45.88%	54	45
<b>Riverview Drive/Industrial Access Road</b>						
East of US 41	6150	9.00%	53.94%	46.06%	299	255
West of US 41	1550	9.00%	75.65%	24.35%	106	34
<b>Madison Avenue/Pendola Point Road</b>						
East of US 41	9100	9.00%	65.65%	34.35%	538	281
West of US 41	1900	9.00%	60.00%	40.00%	103	68
<b>Port Sutton Road</b>						
West of US 41	1650	9.00%	71.74%	28.26%	107	42
<b>Hartford Street</b>						
East of US 41	1600	9.00%	55.47%	44.53%	80	64
West of US 41	270	9.00%	80.77%	19.23%	20	5
<b>Causeway Boulevard</b>						
East of US 41	21450	9.00%	72.06%	27.94%	1391	539
West of US 41	33000	9.00%	77.98%	22.02%	2316	654

US 41 - From Kracker Avenue to South of Causeway Boulevard  
 Estimation of AM Peak Hour Traffic Volumes  
 NB Peak Direction

Recommended AM Peak: 7:00am - 8:00am considered

Intersection	Movement	AM Turning Volume (Raw TMC)	Approach Total	Turn Percent (%)	2013 AM DDHV	2013 Turning Volume
US 41 @ Kracker Avenue	EBLT	3	8	38%	12	5
	EBTH	0		0%		0
	EBRT	5		63%		8
	NBLT	5	1371	0%	1296	5
	NBTH	1360		99%		1286
	NBRT	6		0%		6
	WBLT	8		73%		14
	WBTH	0	11	0%	19	0
	WBRT	3		27%		5
	SBLT	1		0%		1
	SBTH	649	652	100%	752	749
SBRT	2	0%		2		
US 41 @ Ohio Street	NBTH	1367	1380	99%	1354	1341
	NBRT	13		1%		13
	WBLT	16	32	50%	47	24
	WBRT	16		50%		24
	SBLT	43	680	6%	822	52
	SBTH	637		94%		770
US 41 @ Florence Street	EBLT	8	13	62%	16	10
	EBTH	0		0%		0
	EBRT	5		38%		6
	NBLT	5	1460	0%	1478	5
	NBTH	1455		100%		1473
	NBRT	0		0%		0
	WBLT	1		33%		5
	WBTH	0	3	0%	15	0
	WBRT	2		67%		10
	SBLT	2		0%		2
	SBTH	627	640	98%	799	783
SBRT	11	2%		14		
US 41 @ Symmes Road	EBLT	1	1	100%	1	1
	EBTH	0		0%		0
	EBRT	0		0%		0
	NBLT	11	1417	1%	1437	11
	NBTH	1269		90%		1287
	NBRT	137		10%		139
	WBLT	138		30%		121
	WBTH	0	461	0%	405	0
	WBRT	323		70%		284
	SBLT	85		15%		127
	SBTH	497	582	85%	870	743
SBRT	0	0%		0		
US 41 @ Palm Avenue	EBLT	13	19	68%	39	27
	EBTH	0		0%		0
	EBRT	6		32%		12
	NBLT	3	1687	0%	1565	3
	NBTH	1678		99%		1557
	NBRT	6		0%		6
	WBLT	2		13%		2
	WBTH	0	16	0%	18	0
	WBRT	14		88%		16
	SBLT	18		3%		27
	SBTH	612	633	97%	934	903
SBRT	3	0%		4		

US 41 - From Kracker Avenue to South of Causeway Boulevard  
 Estimation of AM Peak Hour Traffic Volumes  
 NB Peak Direction

US 41 @ Nundy Avenue	EBLT	1	8	13%	12	2
	EBTH	2		25%		3
	EBRT	5		63%		8
	NBLT	11	1732	1%	1680	11
	NBTH	1703		98%		1652
	NBRT	18		1%		17
	WBLT	19	48	40%	104	41
	WBTH	0		0%		0
	WBRT	29		60%		63
	SBLT	17	604	3%	896	25
	SBTH	585		97%		868
SBRT	2	0%		3		
US 41 @ Gibsonton Drive/Alice Avenue	EBLT	12	39	31%	45	14
	EBTH	22		56%		25
	EBRT	5		13%		6
	NBLT	11	1728	1%	1611	10
	NBTH	1507		87%		1405
	NBRT	210		12%		196
	WBLT	136	373	36%	585	213
	WBTH	27		7%		42
	WBRT	210		56%		329
	SBLT	112	539	21%	912	190
	SBTH	419		78%		709
SBRT	8	1%		14		
US 41 @ Riverview Drive/Industrial Access Road	EBLT	6	28	21%	34	7
	EBTH	9		32%		11
	EBRT	13		46%		16
	NBLT	59	1874	3%	1640	52
	NBTH	1639		87%		1434
	NBRT	176		9%		154
	WBLT	126	226	56%	299	167
	WBTH	14		6%		19
	WBRT	86		38%		114
	SBLT	8	431	2%	857	16
	SBTH	409		95%		813
SBRT	14	3%		28		
US 41 @ Madison Avenue/Pendola Point Road	EBLT	23	36	64%	68	43
	EBTH	4		11%		8
	EBRT	9		25%		17
	NBLT	14	1928	1%	1542	11
	NBTH	1856		96%		1484
	NBRT	58		3%		46
	WBLT	50	409	12%	538	66
	WBTH	12		3%		16
	WBRT	347		85%		456
	SBLT	152	581	26%	1040	272
	SBTH	401		69%		718
SBRT	28	5%		50		

US 41 - From Kracker Avenue to South of Causeway Boulevard  
 Estimation of AM Peak Hour Traffic Volumes  
 NB Peak Direction

US 41 @ Port Sutton Road	EBLT	19	26	73%
	EBRT	7		27%
	NBLT	25	2206	1%
	NBTH	2181		99%
	SBTH	582	623	93%
	SBRT	41		7%
US 41 @ Hartford Street	EBLT	3	5	60%
	EBRT	2		40%
	NBLT	9	2205	0%
	NBTH	2179		99%
	NBRT	17	48	1%
	WBLT	8		17%
	WBRT	40		83%
	SBLT	37	724	5%
	SBTH	675		93%
	SBRT	12		2%
US 41 @ Causeway Boulevard	EBLT	46	664	7%
	EBTH	295		44%
	EBRT	323	2319	49%
	NBLT	1401		60%
	NBTH	867	1150	37%
	NBRT	51		2%
	WBLT	51		4%
	WBTH	901	464	78%
	WBRT	198		17%
	SBLT	100		22%
	SBTH	314		68%
	SBRT	50		11%

42	31
	11
1871	21
	1850
1048	979
	69
5	3
	2
	8
	1864
1886	15
	13
80	67
	60
	1092
1171	19
	45
	291
654	318
	1272
2105	787
	46
	62
	1090
1391	239
	164
	516
762	82



**US 41 PD&E - From Kracker Avenue to Causeway Boulevard**

**Calculation of DDHVs from AADTs - PM Peak**

Traffic Count Location	2013 AADT	K	D-Peak	D-Off Peak	Peak DDHV	Off Peak DDHV
<b>US 41</b>						
South of Kracker Avenue	22400	9.00%	64.27%	35.73%	1296	720
Kracker Avenue - Ohio Street	23400	9.00%	64.27%	35.73%	1354	752
Ohio Street - Florence Street	25550	9.00%	64.27%	35.73%	1478	822
Florence Street - Symmes Road	24850	9.00%	64.27%	35.73%	1437	799
Symmes Road - Palm Avenue	27050	9.00%	64.27%	35.73%	1565	870
Palm Avenue - Nundy Avenue	29050	9.00%	64.27%	35.73%	1680	934
Nundy Avenue - Gibsonton Drive	27850	9.00%	64.27%	35.73%	1611	896
Gibsonton Drive - Riverview Drive	28350	9.00%	64.27%	35.73%	1640	912
Riverview Drive - Madison Avenue	26650	9.00%	64.27%	35.73%	1542	857
Madison Avenue - Port Sutton Road	32350	9.00%	64.27%	35.73%	1871	1040
Port Sutton Road - Hartford Street	32600	9.00%	64.27%	35.73%	1886	1048
Hartford Street - Causeway Boulevard	36400	9.00%	64.27%	35.73%	2105	1171
North of Causeway Boulevard	23700	9.00%	64.27%	35.73%	1371	762
<b>Kracker Avenue</b>						
East of US 41	340	9.00%	54.17%	45.83%	17	14
West of US 41	240	9.00%	69.23%	30.77%	15	7
<b>Ohio Street</b>						
East of US 41	1450	9.00%	70.43%	29.57%	92	39
<b>Florence Street</b>						
East of US 41	270	9.00%	55.56%	44.44%	14	11
West of US 41	400	9.00%	51.22%	48.78%	18	18
<b>Symmes Road</b>						
East of US 41	6650	9.00%	70.14%	29.86%	420	179
West of US 41	100	9.00%	83.33%	16.67%	7	2
<b>Palm Avenue</b>						
East of US 41	500	9.00%	64.47%	35.53%	29	16
West of US 41	570	9.00%	51.06%	48.94%	26	25
<b>Nundy Avenue</b>						
East of US 41	2050	9.00%	55.42%	44.58%	102	82
West of US 41	350	9.00%	51.43%	48.57%	16	15
<b>Gibsonton Drive/Alice Avenue</b>						
East of US 41	12500	9.00%	66.24%	33.76%	745	380
West of US 41	1100	9.00%	60.92%	39.08%	60	39
<b>Riverview Drive/Industrial Access Road</b>						
East of US 41	6150	9.00%	59.96%	40.04%	332	222
West of US 41	1550	9.00%	75.25%	24.75%	105	35
<b>Madison Avenue/Pendola Point Road</b>						
East of US 41	9100	9.00%	67.28%	32.72%	551	268
West of US 41	1900	9.00%	83.33%	16.67%	142	29
<b>Port Sutton Road</b>						
West of US 41	1650	9.00%	87.88%	12.12%	131	18
<b>Hartford Street</b>						
East of US 41	1600	9.00%	52.25%	47.75%	75	69
West of US 41	270	9.00%	61.11%	38.89%	15	9
<b>Causeway Boulevard</b>						
East of US 41	21450	9.00%	67.79%	32.21%	1309	622
West of US 41	33000	9.00%	73.11%	26.89%	2171	799

US 41 - From Kracker Avenue to South of Causeway Boulevard  
 Estimation of PM Peak Hour Traffic Volumes  
 SB Peak Direction

Recommended PM Peak: 4:45pm - 5:45pm considered

Intersection	Movement	PM Turning Volume (Raw TMC)	Approach Total	Turn Percent (%)	2013 PM DDHV	2013 Turning Volume
US 41 @ Kracker Avenue	EBLT	2	4	50%	7	4
	EBTH	0		0%		0
	EBRT	2		50%		4
	NBLT	5	686	1%	720	5
	NBTH	674		98%		707
	NBRT	7		1%		7
	WBLT	6	13	46%	17	8
	WBTH	1		8%		1
	WBRT	6		46%		8
	SBLT	4	1394	0%	1354	4
	SBTH	1387		99%		1347
SBRT	3	0%		3		
US 41 @ Ohio Street	NBTH	664	674	99%	752	741
	NBRT	10		1%		11
	WBLT	12	34	35%	39	14
	WBRT	22		65%		25
	SBLT	71		5%		74
SBTH	1345	1416	95%	1478	1404	
US 41 @ Florence Street	EBLT	15	21	71%	18	13
	EBTH	0		0%		0
	EBRT	6		29%		5
	NBLT	8	743	1%	822	9
	NBTH	734		99%		812
	NBRT	1		0%		1
	WBLT	1	4	25%	11	3
	WBTH	0		0%		0
	WBRT	3		75%		8
	SBLT	4	1365	0%	1437	4
	SBTH	1349		99%		1420
SBRT	12	1%		13		
US 41 @ Symmes Road	EBLT	0	1	0%	2	0
	EBTH	1		100%		2
	EBRT	0		0%		0
	NBLT	2	764	0%	799	2
	NBTH	680		89%		711
	NBRT	82		11%		86
	WBLT	79	169	47%	179	84
	WBTH	0		0%		0
	WBRT	90		53%		95
	SBLT	314	1528	21%	1565	322
SBTH	1211	79%		1240		
SBRT	3	0%		3		
US 41 @ Palm Avenue	EBLT	19	24	79%	26	21
	EBTH	2		8%		2
	EBRT	3		13%		3
	NBLT	4	878	0%	870	4
	NBTH	865		99%		857
	NBRT	9		1%		9
	WBLT	40	98	41%	29	12
	WBTH	2		2%		1
	WBRT	56		57%		17
	SBLT	43	1693	3%	1680	43
	SBTH	1633		96%		1620
SBRT	17	1%		17		

US 41 - From Kracker Avenue to South of Causeway Boulevard  
 Estimation of PM Peak Hour Traffic Volumes  
 SB Peak Direction

US 41 @ Nundy Avenue	EBLT	4	17	24%	934	4
	EBTH	0		0%		0
	EBRT	13		76%		11
	NBLT	9	826	1%		10
	NBTH	772		93%		873
	NBRT	45	5%	51		
	WBLT	47	74	64%		52
	WBTH	2		3%		2
	WBRT	25		34%		28
	SBLT	47	1716	3%		44
	SBTH	1662		97%		1560
SBRT	7	0%		7		
US 41 @ Gibsonton Drive/Alice Avenue	EBLT	7	34	21%	896	8
	EBTH	16		47%		18
	EBRT	11		32%		13
	NBLT	9	839	1%		10
	NBTH	575		69%		614
	NBRT	255	30%	272		
	WBLT	223	346	64%		245
	WBTH	30		9%		33
	WBRT	93		27%		102
	SBLT	408	1754	23%		381
	SBTH	1332		76%		1245
SBRT	14	1%		13		
US 41 @ Riverview Drive/Industrial Access Road	EBLT	16	76	21%	912	22
	EBTH	27		36%		37
	EBRT	33		43%		46
	NBLT	10	697	1%		13
	NBTH	490		70%		641
	NBRT	197	28%	258		
	WBLT	196	219	89%		199
	WBTH	4		2%		4
	WBRT	19		9%		19
	SBLT	104	1735	6%		92
	SBTH	1620		93%		1440
SBRT	11	1%		10		
US 41 @ Madison Avenue/Pendola Point Road	EBLT	19	30	63%	857	90
	EBTH	9		30%		43
	EBRT	2		7%		9
	NBLT	1	569	0%		2
	NBTH	540		95%		813
	NBRT	28	5%	42		
	WBLT	76	215	35%		95
	WBTH	0		0%		0
	WBRT	139		65%		173
	SBLT	405	2087	19%		363
	SBTH	1677		80%		1503
SBRT	5	0%		4		
					1871	

US 41 - From Kracker Avenue to South of Causeway Boulevard  
 Estimation of PM Peak Hour Traffic Volumes  
 SB Peak Direction

US 41 @ Port Sutton Road	EBLT	17	29	59%	131	77	
	EBRT	12		41%		54	
	NBLT	0		0%		0	
	NBTH	728	728	100%		1040	1040
	SBTH	2130	2134	100%		1882	
	SBRT	4		0%		4	
US 41 @ Hartford Street	EBLT	7	11	64%	15	10	
	EBRT	4		36%		5	
	NBLT	5		1%		7	
	NBTH	774		97%		1022	
	NBRT	15	794	2%	1048	20	
	WBLT	15	58	26%	75	19	
	WBRT	43		74%		56	
	SBLT	38		2%		37	
	SBTH	2120		98%		2066	
	SBRT	2	2160	0%	2105	2	
US 41 @ Causeway Boulevard	EBLT	61	2099	3%	2171	63	
	EBTH	821		39%		849	
	EBRT	1217		58%		1259	
	NBLT	410		45%		528	
	NBTH	396		44%		510	
	NBRT	103		909		11%	1171
	WBLT	55	545	10%	622	63	
	WBTH	343		63%		391	
	WBRT	147		27%		168	
	SBLT	223		21%		294	
	SBTH	797		77%		1052	
	SBRT	19		1039		2%	1371

**APPENDIX E**  
**DEVELOPMENT OF EXISTING TRAFFIC**  
**VOLUMES**

US 41 MAINLINE

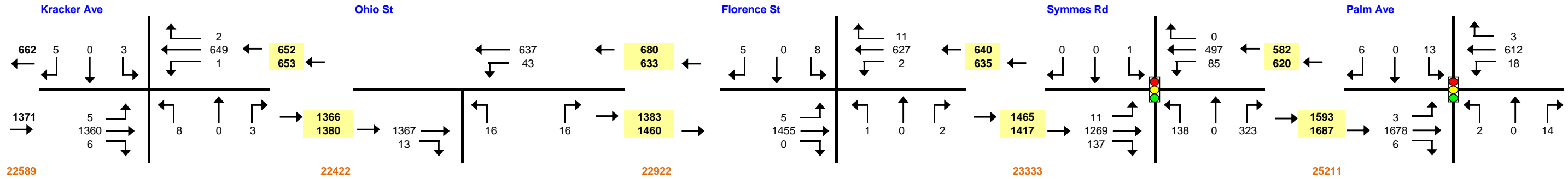

US 41 MAINLINE

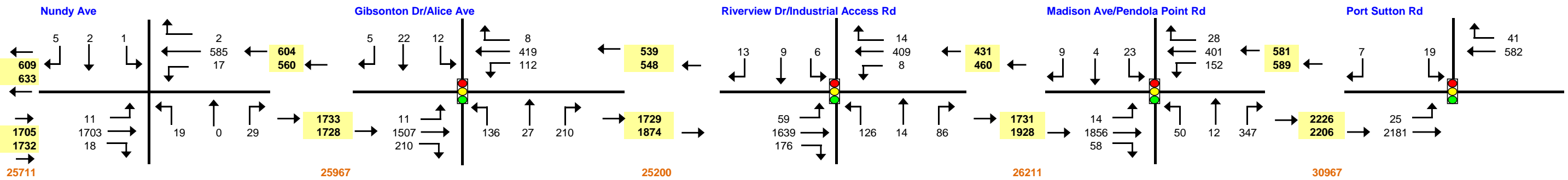

US 41 MAINLINE

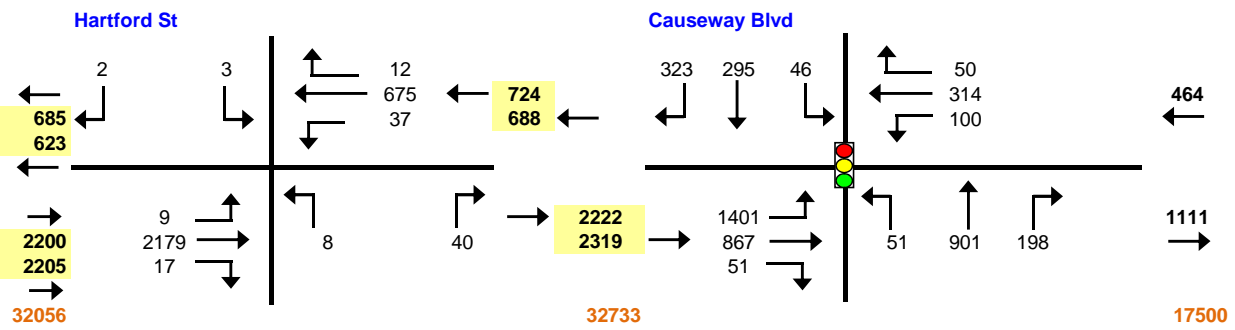

LEGEND	
	Signalized Intersection

Proposed AM Peak: 7:00am - 8:00am

US 41 PD&E  
 from Kracker Avenue to South of Causeway Boulevard  
 Hillsborough County, Florida

RAW EXISTING YEAR 2013 AM PEAK HOUR TRAFFIC VOLUMES

US 41 MAINLINE

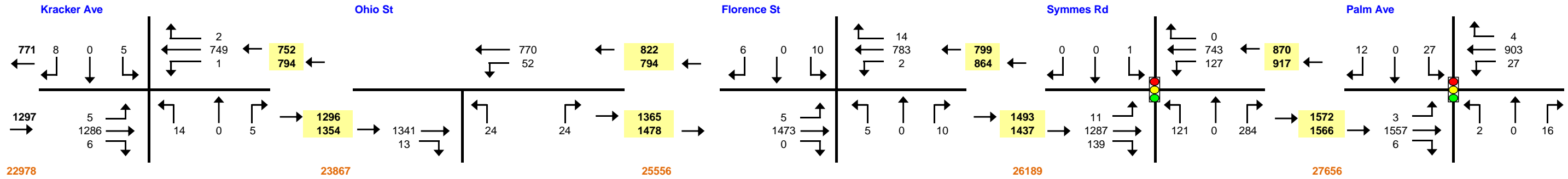

US 41 MAINLINE

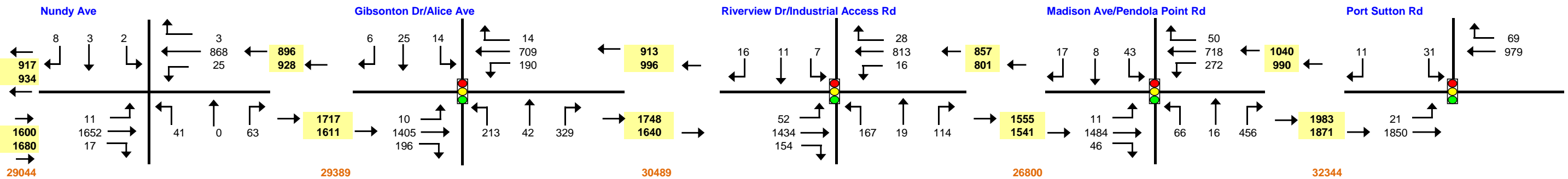

US 41 MAINLINE

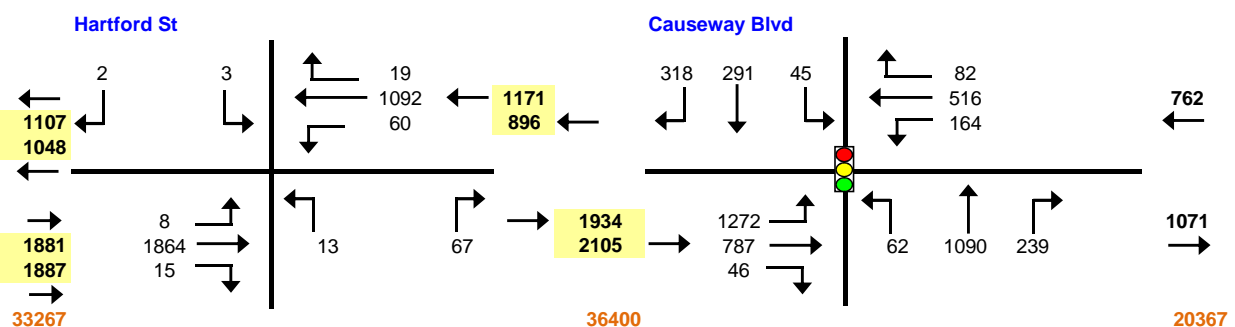

**LEGEND**

 Signalized Intersection

US 41 PD&E  
from Kracker Avenue to South of Causeway Boulevard  
Hillsborough County, Florida

**ORIGINAL EXISTING YEAR 2013 AM PEAK HOUR TRAFFIC VOLUMES**

US 41 MAINLINE

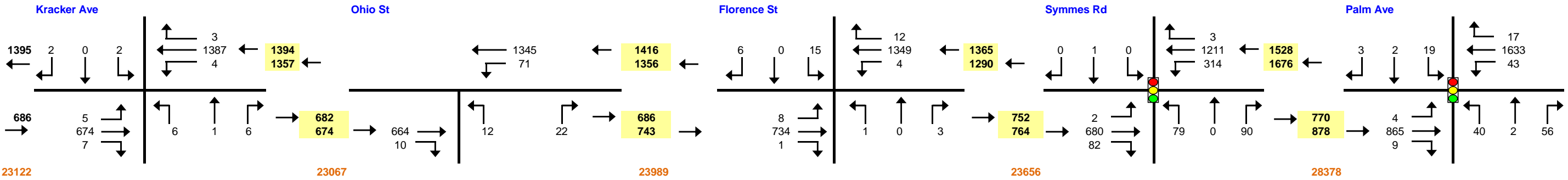

US 41 MAINLINE

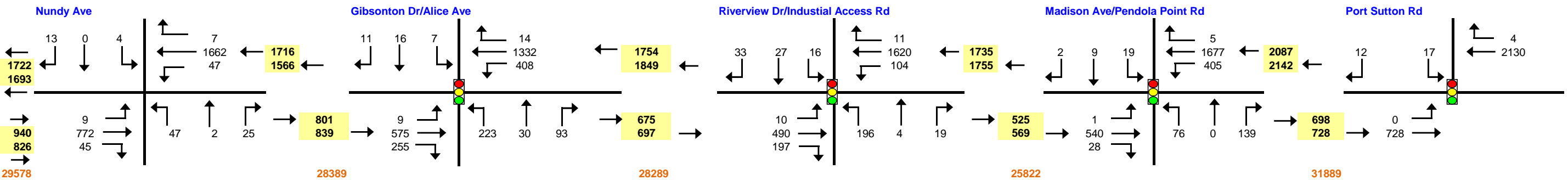

US 41 MAINLINE

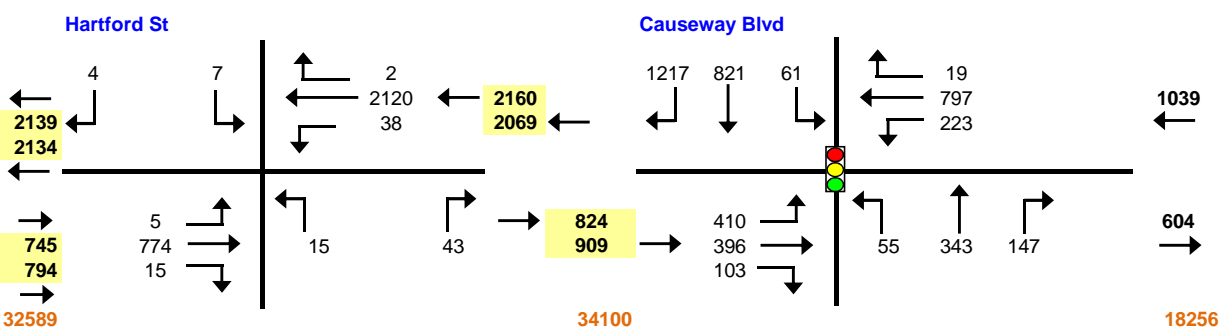

**LEGEND**

Signalized Intersection

Proposed PM Peak: 4:45pm - 5:45pm

**US 41 PD&E**  
 from Kracker Avenue to South of Causeway Boulevard  
 Hillsborough County, Florida

**RAW EXISTING YEAR 2013 PM PEAK HOUR TRAFFIC VOLUMES**



US 41 MAINLINE

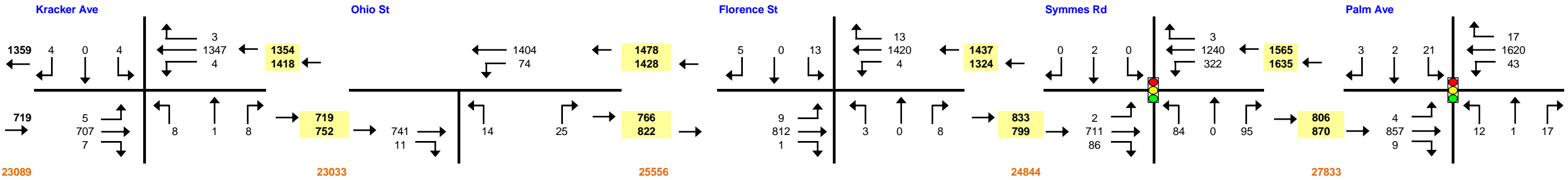

US 41 MAINLINE

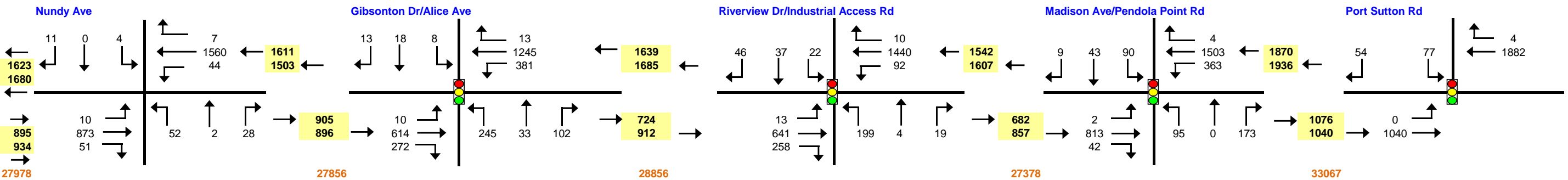

US 41 MAINLINE

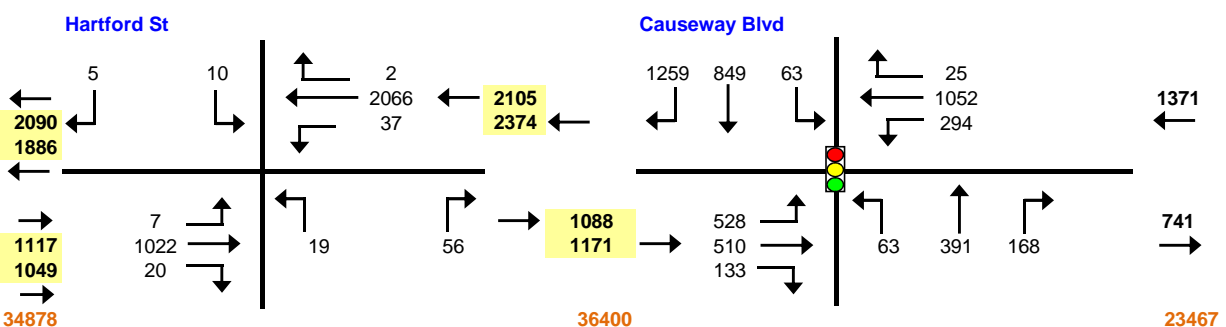

**LEGEND**

 Signalized Intersection

**US 41 PD&E**  
 from Kracker Avenue to South of Causeway Boulevard  
 Hillsborough County, Florida

**ORIGINAL EXISTING YEAR 2013 PM PEAK HOUR TRAFFIC VOLUMES**

**APPENDIX F**  
**SUBAREA VALIDATION**

**US 41 PD&E STUDY**  
**From Kracker Avenue to Causeway Boulevard**  
**Hillsborough County, Florida**

**SUBAREA VALIDATION**  
**FOR THE BASE YEAR 2006 TAMPA BAY REGIONAL**  
**PLANNING MODEL (TBRPM Version 7.1)**

**FLORIDA DEPARTMENT OF TRANSPORTATION**  
**DISTRICT 7**

**April 2013**

## Base Year Model Validation

A base year (2006) model validation (reasonableness check) of the Tampa Bay Regional Planning Model (TBRPM) Version 7.1 was performed for the study area along US 41 from Kracker Avenue to Causeway Boulevard as shown in **Table 1** below. Several model volumes (shown as highlighted) were not found to be within acceptable accuracy levels (deviation from NCHRP 255 procedure).

**TABLE 1: 2006 Model Volume Comparison with 2006 Traffic Counts**

Links	2006 Count ©	2006 Model Volume (V)	V/C Ratio	% Deviation <sup>(2)</sup>	Acceptable % Deviation from NCHRP 255 <sup>(1)</sup>
US 41					
North of Causeway Blvd	11500	14524	1.26	26%	35%
	11500	14781	1.29	29%	35%
South of Causeway Blvd	17250	26184	1.52	52%	30%
	17250	25784	1.49	49%	30%
South of Madison Ave	11000	21256	1.93	93%	35%
	11000	21071	1.92	92%	35%
North of Big Bend Rd	10750	16439	1.53	53%	36%
	10750	15663	1.46	46%	36%
South of Big Bend Rd	14000	18448	1.32	32%	32%
	14000	17795	1.27	27%	32%
Causeway Blvd					
West of US 41	14750	18102	1.23	23%	31%
	14750	20319	1.38	38%	31%
East of US 41	13750	8705	0.63	(-)37%	32%
	13750	10267	0.75	(-)25%	32%
Riverview Dr					
East of US 41	3650	2156	0.59	(-)41%	50%
	3650	1869	0.51	(-)49%	50%
Gibsonton Dr					
East of US 41	9000	6335	0.70	(-)30%	37%
	9000	6525	0.73	(-)27%	37%
Symmes Rd					
East of US 41	3850	4286	1.11	11%	49%
	3850	3712	0.96	(-)4%	49%
Big Bend Rd					
East of US 41	13000	12381	0.95	(-)5%	34%
	13000	12504	0.96	(-)4%	34%

<sup>(1)</sup> National Cooperative Highway Research Program (NCHRP) Report 255: Highway Traffic Data for Urbanized Area Project Planning and Design

<sup>(2)</sup> Highlighted values exceed the acceptable % deviation from NCHRP 255.

The plots for the model volume-over-count ratios for the original base year 2006 TBRPM model have been provided in **Attachment A**.

The highway network within the project limits was reviewed including centroid connectors, facility types and area types, in order to improve the accuracy level of the base year model. The following modifications/refinements were made to the base year model as a part of the subarea validation.

- Facility type on all the links along US 41 from Big Bend Road to Causeway Boulevard has been revised to 24 (divided arterial class 1b) instead of 23 (divided arterial class 1a).
- Centroid connectors 717 – 5109 and 684 – 5415 have been removed based on the review. These connected to US 41 but these traffic analysis zones are connected to the roadway network by other existing centroid connectors.
- Nodes 672, 683, 694 and 710 have been moved to the east of their original positions in the base year model.

The base year 2006 model was re-run with the above mentioned modifications/refinements and the resulting model volume-over-count ratios are provided in **Table 2**.

The plots for the model volume-over-count ratios resulting from the re-run of the base year 2006 TBRPM model with modifications/refinements have also been provided in **Attachment A**.

**TABLE 2: Revised 2006 Model Volume Comparison with 2006 Traffic Counts**

Links	2006 Count ©	2006 Model Volume (V)	V/C Ratio	% Deviation <sup>(2)</sup>	Acceptable % Deviation from NCHRP 255 <sup>(1)</sup>
US 41					
North of Causeway Blvd	11500	13633	1.19	19%	35%
	11500	12622	1.10	10%	35%
South of Causeway Blvd	17250	23431	1.36	36%	30%
	17250	22846	1.32	32%	30%
South of Madison Ave	11000	17644	1.60	60%	35%
	11000	17315	1.57	57%	35%
North of Big Bend Rd	10750	13599	1.27	27%	36%
	10750	13091	1.22	22%	36%
South of Big Bend Rd	14000	15599	1.11	11%	32%
	14000	15020	1.07	7%	32%
Causeway Blvd					
West of US 41	14750	18770	1.27	27%	31%
	14750	17961	1.22	22%	31%
East of US 41	13750	10559	0.77	(-)23%	32%
	13750	10175	0.74	(-)26%	32%
Riverview Dr					
East of US 41	3650	2172	0.60	(-)40%	50%
	3650	1913	0.52	(-)48%	50%
Gibsonston Dr					
East of US 41	9000	5634	0.63	(-)37%	37%
	9000	6464	0.72	28%	37%
Symmes Rd					
East of US 41	3850	5434	1.41	41%	49%
	3850	4701	1.22	22%	49%
Big Bend Rd					
East of US 41	13000	11260	0.87	(-)13%	34%
	13000	11190	0.86	(-)14%	34%

<sup>(1)</sup> National Cooperative Highway Research Program (NCHRP) Report 255: Highway Traffic Data for Urbanized Area Project Planning and Design

<sup>(2)</sup> Highlighted values exceed the acceptable % deviation from NCHRP 255.

A comparison of the model volume-over-count ratios listed in **Table 1** and **Table 2** indicates that the network coding revisions resulted in improvement in the 2006 model validation accuracy. The revised base year model run showed that fewer links are not within the desired level of accuracy. This was discussed with Florida Department of Transportation (FDOT) – District 7 in a meeting on March 28, 2013. It was agreed upon with FDOT that these refinements be made to the future year 2035 build model and the resulting 2035 model volumes be adjusted using NCHRP 255 Ratio and Difference Method techniques.

Therefore, the subarea validation refinements were applied to the future year 2035 model for the build scenario with 6 lanes along US 41 from Kracker Avenue to Causeway Boulevard. Also, for the future year model, the 2035 socioeconomic (SE) data for the traffic analysis zones (TAZ) within the US 41 study area was compared to the SE data included in the socio-economic analysis conducted by Renaissance Planning Group on behalf of the Tampa-Hillsborough County Expressway Authority (THEA). As the difference between the two data sets of SE data was not significant, no adjustment to the SE data from the Adopted model was made. This was discussed and agreed upon with FDOT – District 7 on March 22, 2013. The SE data comparison has been included in **Appendix B**.

**ATTACHMENT A**  
**SUBAREA VALIDATION MODEL PLOTS**



Tampa Bay Regional Planning Model 7.1  
Base Year 2006 Original Model

Model Volume (V)  
Counts (C)  
V/C Ratio

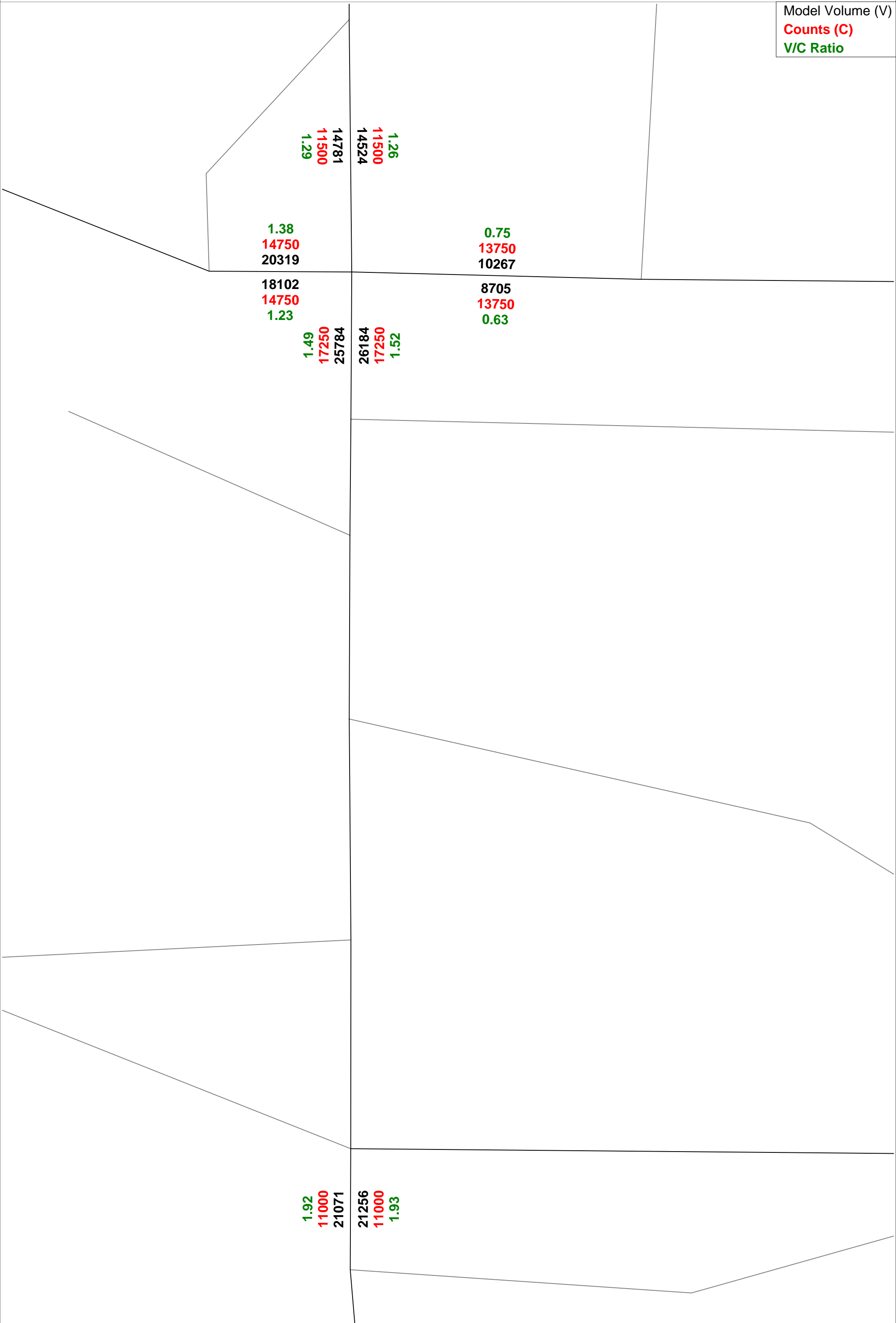

Tampa Bay Regional Planning Model 7.1  
Base Year 2006 Original Model

Model Volume (V)  
Counts (C)  
V/C Ratio

1.92  
11000  
21071

21256  
11000  
1.93

0.81  
6500  
5267

5408  
6500  
0.83

0.55  
6250  
3448

1.45  
2650  
3842

3208  
6250  
0.51  
2650  
32

0.51  
3650  
1869

2156  
3650  
0.59

0.73  
9000  
6525

6335  
9000  
0.7

Tampa Bay Regional Planning Model 7.1  
Base Year 2006 Original Model

Model Volume (V)  
Counts (C)  
V/C Ratio

9000  
6525

6335  
9000  
0.7

0.96  
3850  
3712

4286  
3850  
1.11

1.46  
10750  
15663

16439  
10750  
1.53

0.96  
13000  
12504

1.27  
14000  
17795

18448  
14000  
1.32  
12381  
13000  
0.95

1.07  
48500  
51884

51543  
48500  
1.06



Tampa Bay Regional Planning Model 7.1  
Base Year 2006 Original Model

Model Volume (V)  
Counts (C)  
V/C Ratio

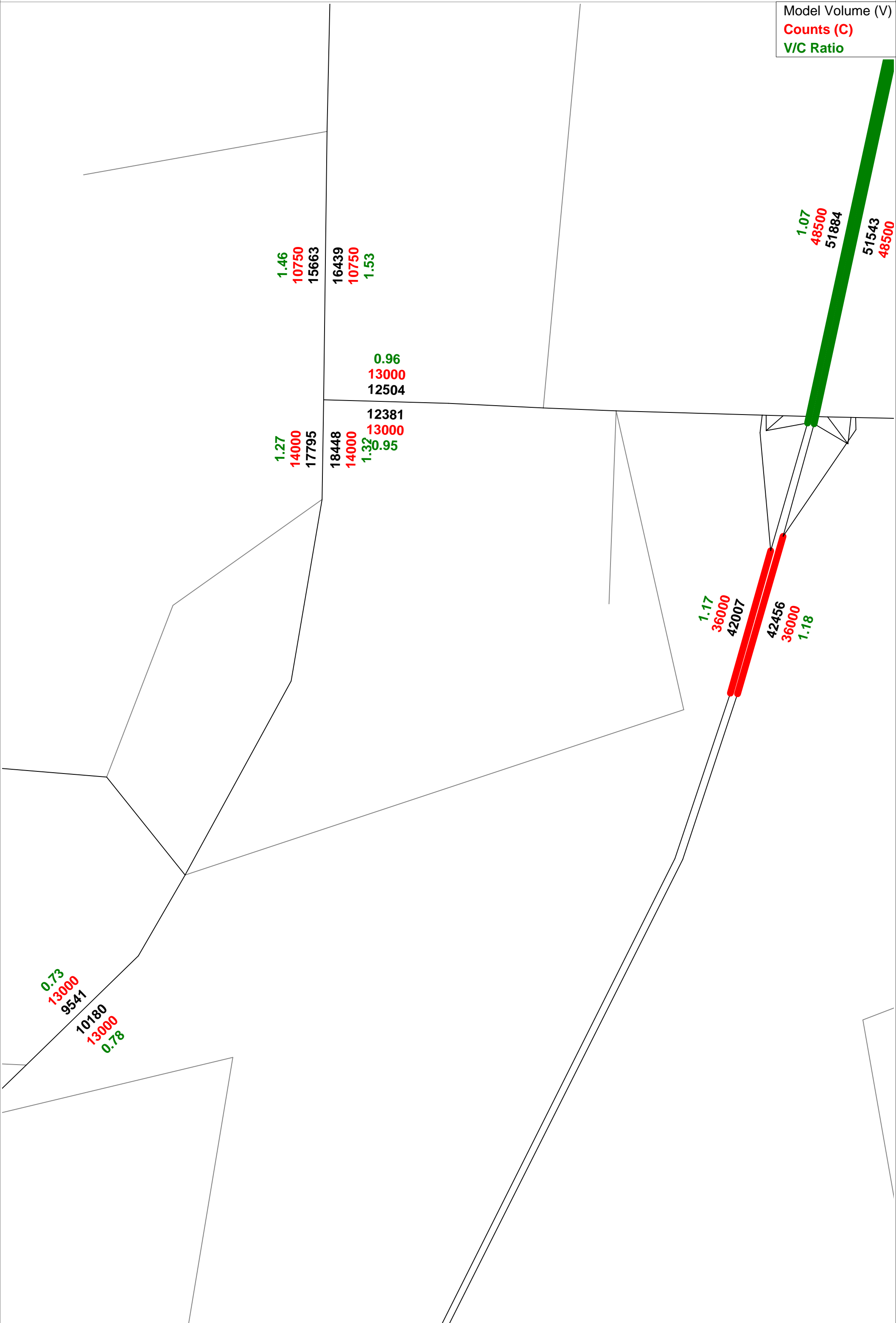

Tampa Bay Regional Planning Model 7.1  
Base Year 2006 with Subarea Validation Refinements

Model Volume (V)  
Counts (C)  
V/C Ratio

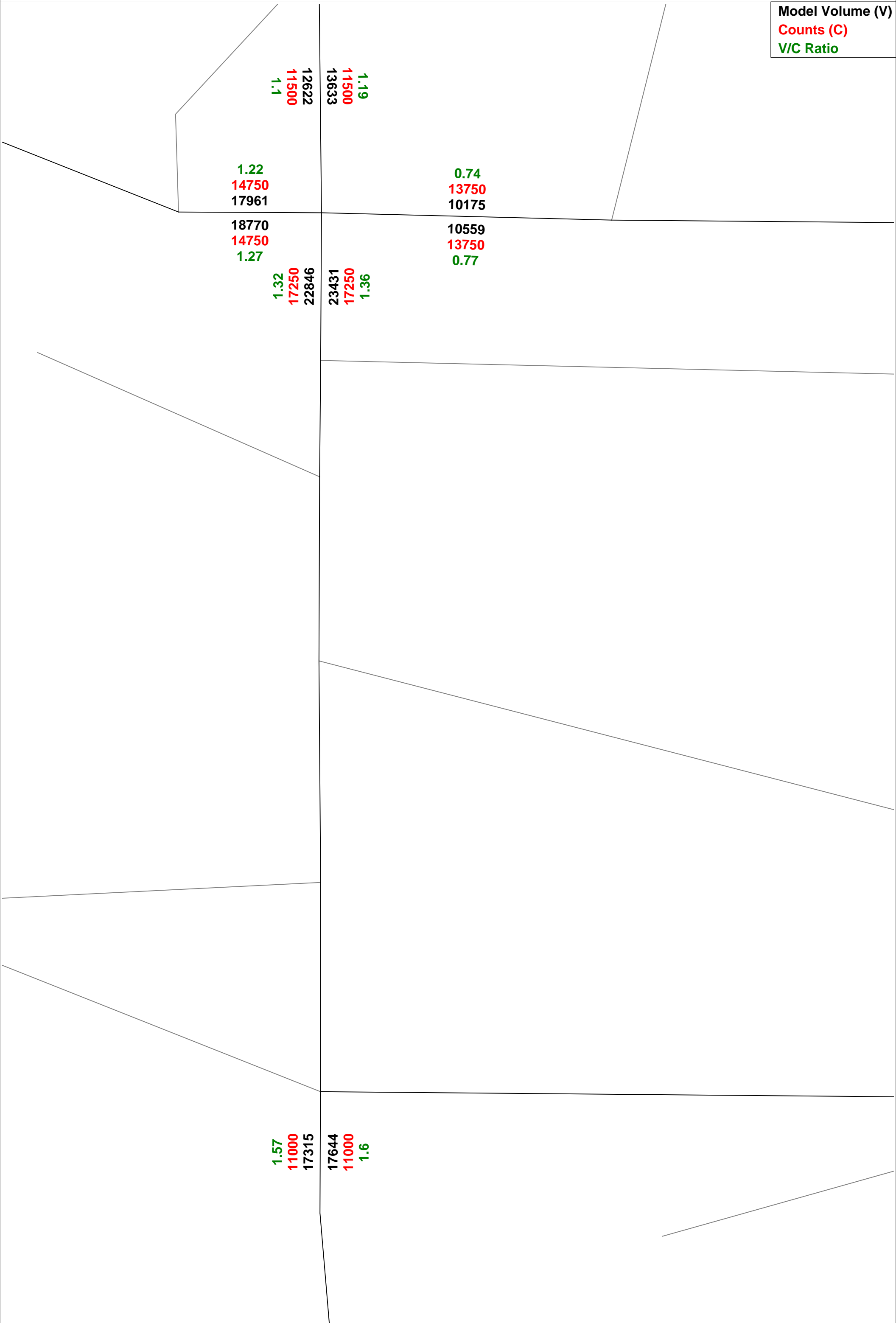

Tampa Bay Regional Planning Model 7.1  
 Base Year 2006 with Subarea Validation Refinements

Model Volume (V)  
 Counts (C)  
 V/C Ratio



Tampa Bay Regional Planning Model 7.1  
 Base Year 2006 with Subarea Validation Refinements

Model Volume (V)  
 Counts (C)  
 V/C Ratio

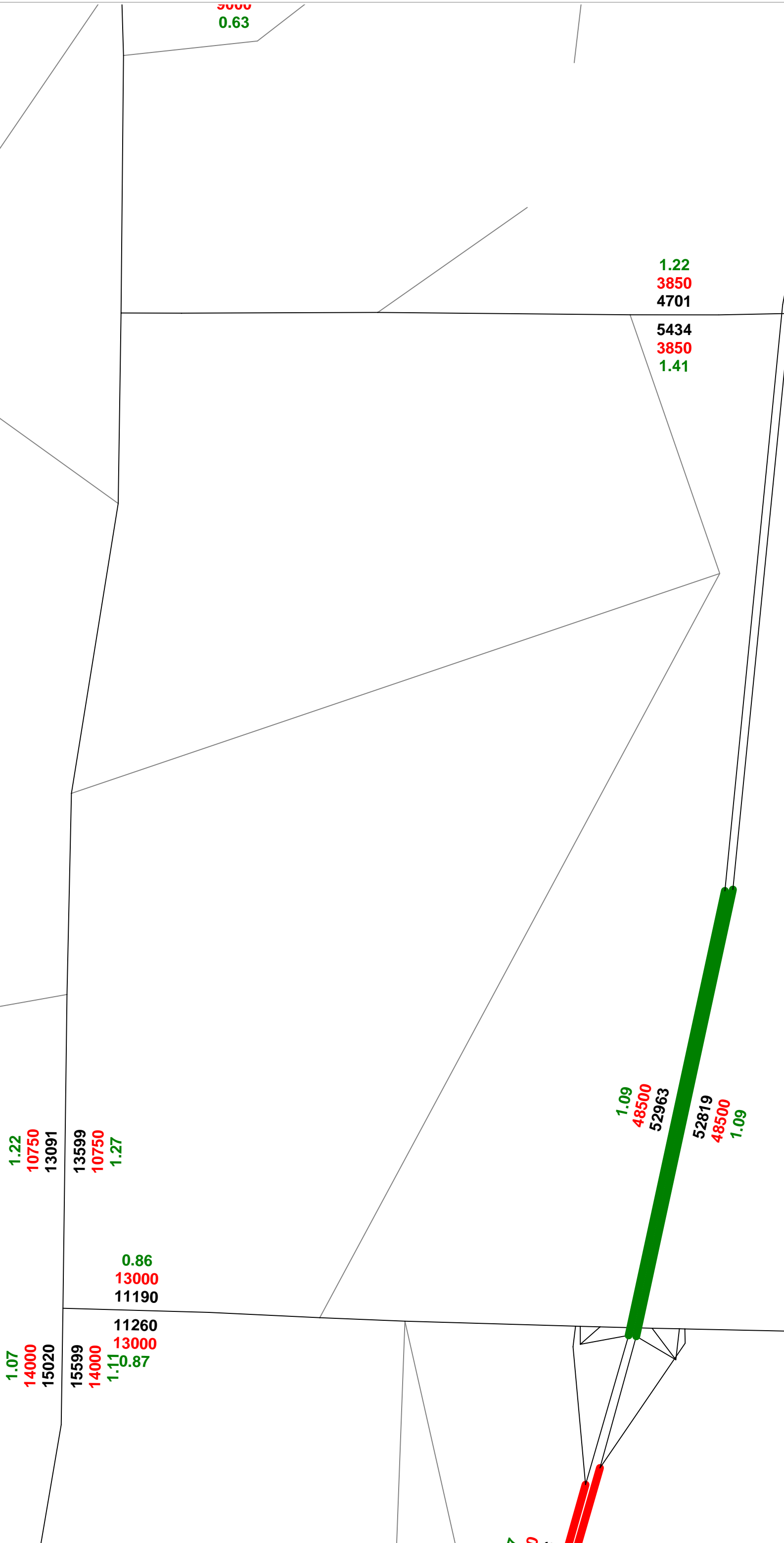

Tampa Bay Regional Planning Model 7.1  
Base Year 2006 with Subarea Validation Refinements

Model Volume (V)  
Counts (C)  
V/C Ratio

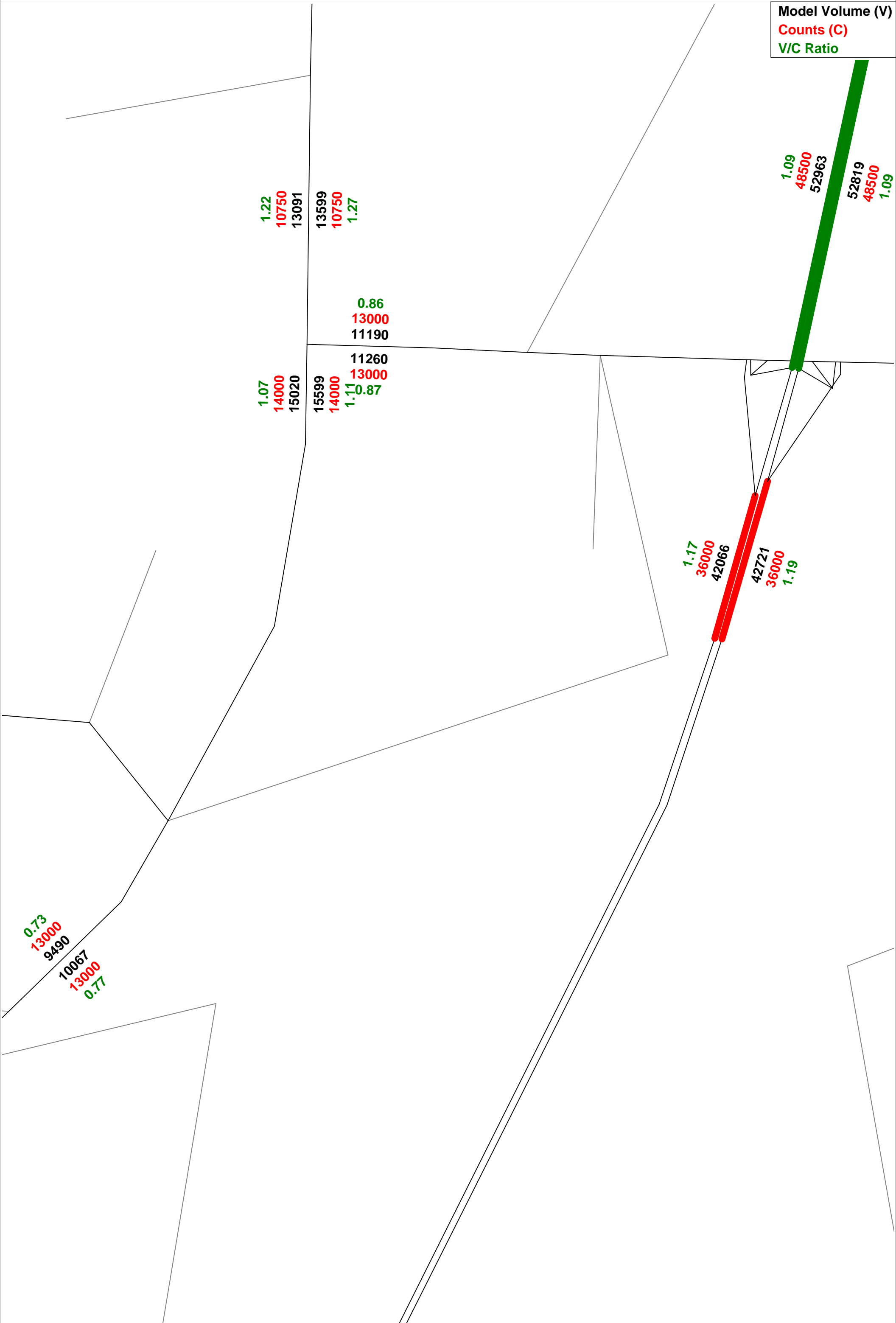



**ATTACHMENT B**

**FUTURE YEAR SOCIOECONOMIC DATA COMPARISON**

**(Comparing Adopted 2035 model to Adjustments developed  
by Renaissance Planning Group for THEA)**

**US 41 PD&E Study – from Kracker Avenue to South of Causeway Boulevard**  
**Financial Project ID: 430056-1-22-01**

The economic recession and housing crisis of 2008 and beyond raise questions about their long term consequences with respect to travel demand in the US 41 corridor. In the buildup to the housing crisis, south Hillsborough County land was developing rapidly and a significant number of residential projects broke ground. The US Census results from 2010 show continued growth in the number of dwelling units in the area despite economic conditions. While the long term effects on the housing market in south Hillsborough County are less certain, official forecasts point to continued strong population growth and household formation in Hillsborough County over the long term. The employment picture is different. The economic recession hit Florida and Hillsborough County particularly hard and unemployment rates are not projected to normalize to pre-recession levels until after 2025. In contrast to this employment trend in real space and time, the Tampa Bay Regional Planning Model (TBRPM) forecasts include a declining population to employment ratio over time. This is the opposite direction from the short term trend over the past five years and significantly overstates the long term relationship between population and the number of jobs available per person. In order to more accurately capture the effects of these phenomena, the following adjustments to the US 41 corridor traffic analysis zones (TAZs) are recommended:

	Employment	Dwelling Units
2025	-10.55%	1.59%
2035	-2.00%	4.01%

These numbers are reflective of the findings of a significant amount of economic analysis conducted by Renaissance Planning Group on behalf of the Tampa-Hillsborough County Expressway Authority (THEA). This work occurred in three phases over the past four years. It included adjusted dwelling unit and employment totals based on a five county TBRPM, north Manatee County and Polk County analysis. This included a focus on Hillsborough County where county control totals, employment sub-markets, and traffic analysis zones were assessed for reasonableness against macroeconomic trends, regional economic factors and land availability conditions. The work concluded in late 2012 and adjustments to the original independent forecast were made based on current economic and housing market conditions. The recommended adjustments to the US 41 corridor are the culmination of that work.

There were three phases to the independent economic analysis Renaissance did for THEA:

Phase I analysis resulted in:

- The creation of new 2015 and 2049 data sets;

**US 41 PD&E Study – from Kracker Avenue to South of Causeway Boulevard**  
**Financial Project ID: 430056-1-22-01**

- Adjusting up or down employment or dwelling units for certain TAZs (None of the adjacent US 41 corridor TAZs were affected by this);
- Adjusting external station trips based on anticipated growth rates (including Manatee County)
- Determining valid special generators data for 2006 and creation of data for 2015 (2006 was determined valid at the time relative to assumptions in Tampa Port Authority Master Plan, the forecasts of which have since been revisited as previously discussed); and
- The adjustment of population (as a proxy for dwelling units) and employment for all analysis years.

Phase II

- While there were some trends that pointed to slightly slower economic recovery than originally forecasted, the analysis resulted in a finding that there was no need to adjust the original data up or down.

Phase III assessment did result in a recommendation for adjusting the data.

- 2012 BEBR forecasts for 2015 and 2025 Hillsborough population are higher than they were in 2009, which was used in the original Phase I adjustment (Renaissance recommended using the 2012 BEBR and adjusting up the population for Hillsborough);
- The 2010 Census information confirms the validity of the short term forecast for the increase in dwelling units at the county and sub-area levels; and
- The Phase I employment forecasts were not negative enough in the short or long term and a wholesale adjustment down was needed for Hillsborough County at the county level.

The adjusted socioeconomic data (zdata1 and zdata2) for the traffic analysis zones (TAZs) within the US 41 study area were compared to that in the adopted Tampa Bay Regional Planning Model (TBRPM) for the future year 2035. These comparisons are presented in Table 1 and Table 2. The study TAZs are shown in Figure 1.

The ZDATA1 and ZDATA2 comparison tables for the study TAZs show that the overall dwelling units were increased from 17,710 to 18,419 while the total employment reduced from 22,974 to 22,515.

US 41 PD&E Study – from Kracker Avenue to South of Causeway Boulevard  
Financial Project ID: 430056-1-22-01

Figure 1 – Study Area Traffic Analysis Zones

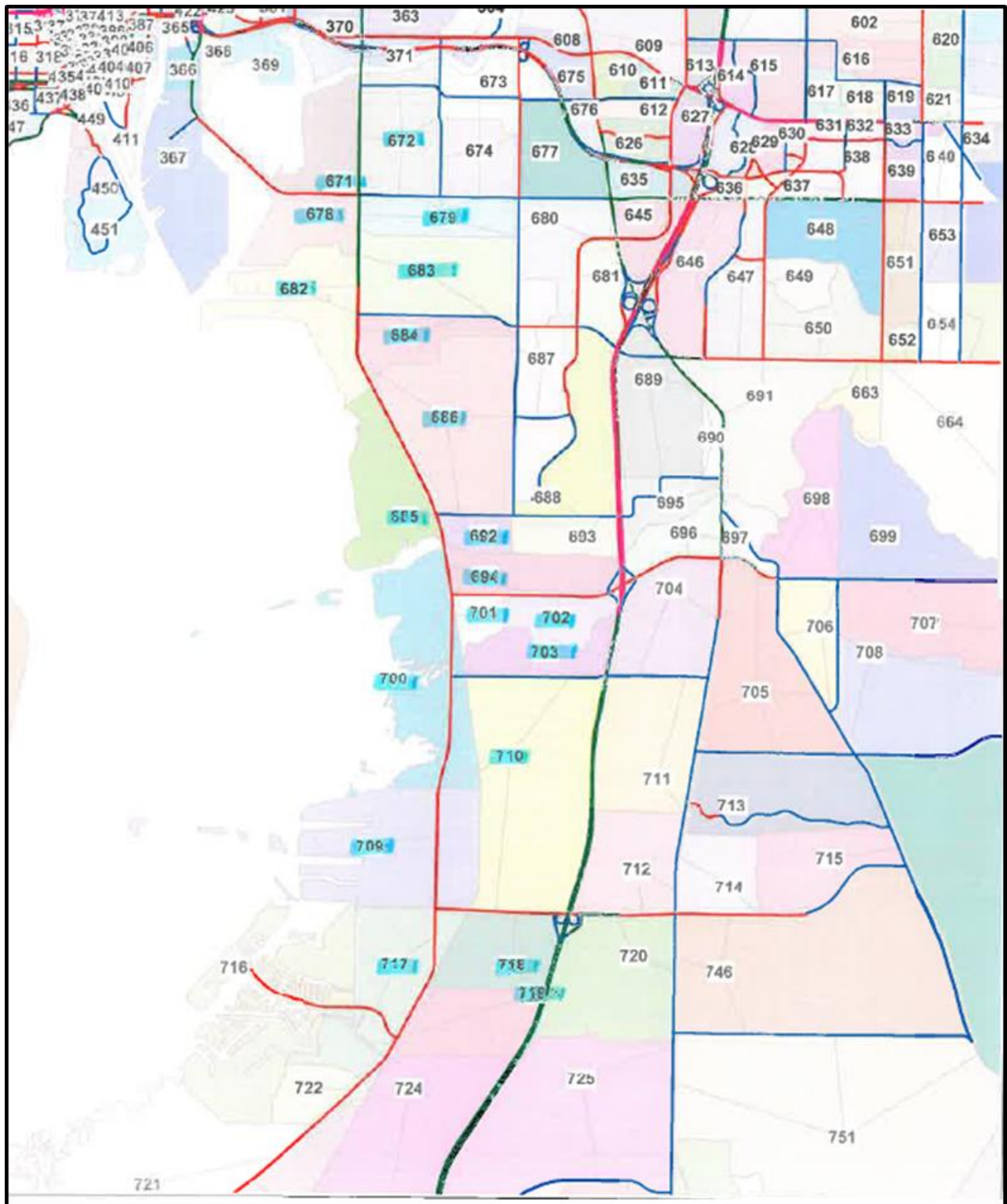

**US 41 PD&E Study – from Kracker Avenue to South of Causeway Boulevard**  
**Financial Project ID: 430056-1-22-01**

**Table 1 - 2035 ZDATA 1 Comparison Table**

<b>TAZ</b>	<b>2035 Dwelling Units Adopted Model Data</b>	<b>2035 Dwelling Units Adjusted Data</b>
<b>671</b>	1,231	1280
<b>672</b>	1,382	1437
<b>678</b>	95	99
<b>679</b>	598	622
<b>682</b>	25	26
<b>683</b>	739	769
<b>684</b>	352	366
<b>685</b>	55	57
<b>686</b>	256	266
<b>692</b>	201	209
<b>694</b>	1,236	1286
<b>700</b>	1,116	1161
<b>701</b>	327	340
<b>702</b>	694	722
<b>703</b>	1,030	1071
<b>709</b>	216	225
<b>710</b>	2,955	3073
<b>717</b>	1,900	1976
<b>718</b>	1,593	1657
<b>719</b>	1,709	1777
<b>Total</b>	<b>17,710</b>	<b>18,419</b>

**Table 2 - 2035 ZDATA 2 Comparison Table**

<b>TAZ</b>	<b>2035 Employment Adopted Model Data</b>						<b>2035 Employment Adjusted Data</b>					
	<b>Ind.</b>	<b>Comm.</b>		<b>Service</b>		<b>Total</b>	<b>Ind.</b>	<b>Comm.</b>		<b>Service</b>		<b>Total</b>
		<b>REMP</b>	<b>LEMP</b>	<b>REMP</b>	<b>LEMP</b>			<b>REMP</b>	<b>LEMP</b>	<b>REMP</b>	<b>LEMP</b>	
<b>671</b>	749	19	67	202	30	1,067	734	19	66	198	29	<b>1,046</b>
<b>672</b>	1,560	128	93	444	238	2,463	1,529	125	91	435	233	<b>2,414</b>
<b>678</b>	753	30	77	393	34	1,287	738	29	75	385	33	<b>1,261</b>
<b>679</b>	613	149	127	588	34	1,511	601	146	124	576	33	<b>1,481</b>
<b>682</b>	775	56	26	605	0	1,462	760	55	25	593	0	<b>1,433</b>
<b>683</b>	1,376	82	128	439	148	2,173	1,348	80	125	430	145	<b>2,130</b>
<b>684</b>	418	158	40	37	30	683	410	155	39	36	29	<b>669</b>
<b>685</b>	367	0	0	12	0	379	360	0	0	12	0	<b>371</b>
<b>686</b>	450	3	66	512	30	1,061	441	3	65	502	29	<b>1,040</b>
<b>692</b>	65	11	0	335	5	416	64	11	0	328	5	<b>408</b>
<b>694</b>	84	37	44	111	30	306	82	36	43	109	29	<b>300</b>
<b>700</b>	281	158	135	424	50	1,048	275	155	132	416	49	<b>1,027</b>
<b>701</b>	93	25	60	377	30	585	91	25	59	369	29	<b>573</b>
<b>702</b>	44	364	138	64	204	814	43	357	135	63	200	<b>798</b>
<b>703</b>	83	80	0	58	5	226	81	78	0	57	5	<b>221</b>
<b>709</b>	712	124	40	768	30	1,674	698	122	39	753	29	<b>1,641</b>
<b>710</b>	244	0	0	301	573	1,118	239	0	0	295	562	<b>1,096</b>
<b>717</b>	540	153	742	1,236	455	3,126	529	150	727	1,211	446	<b>3,064</b>
<b>718</b>	42	529	145	410	80	1,206	41	518	142	402	78	<b>1,182</b>
<b>719</b>	28	128	40	143	30	369	27	125	39	140	29	<b>362</b>
<b>Total</b>	<b>9,277</b>	<b>2,234</b>	<b>1,968</b>	<b>7,459</b>	<b>2,036</b>	<b>22,974</b>	<b>9,092</b>	<b>2,189</b>	<b>1,929</b>	<b>7,310</b>	<b>1,995</b>	<b>22,515</b>

**US 41 PD&E Study – from Kracker Avenue to South of Causeway Boulevard**  
**Financial Project ID: 430056-1-22-01**

These socioeconomic data comparisons were presented to FDOT at March 22, 2013 meeting and it was agreed upon that these adjustments are not significant enough within the US 41 corridor study area to make these adjustments in the model for determining forecast traffic projections for this project. Therefore, the adopted future 2035 model would be used without any changes to the socioeconomic data for the purpose of future traffic forecasting for this project.

## **APPENDIX G**

# **NCHRP 255 ADJUSTMENTS, MODEL PLOTS, COMPUTATION OF MODEL GROWTH RATE FOR SIDE-STREETS AND HISTORICAL TREND ANALYSES**

US 41 PD&E Study From Kracker Avenue to Causeway Boulevard  
 Adjustment of 2035 Build Model Volumes per NCHRP 255 (Ratio and Difference) Method

Segment along US 41	2006 Counts	2006 Model Volume (PSWADT)	2006 Model AADT (=PSWADT*MOCF) MOCF=0.94	2006 Count/2006 Model AADT (2)	2006 Count - 2006 Model AADT (2)	2035 Build Model Volume (PSWADT)	2035 Build Model AADT (=PSWADT*MOCF) MOCF=0.94 (3)	Ratio Method Adjusted 2035 Future Traffic (4)	Difference Method Adjusted 2035 Future Traffic (5)	NCHRP 255 Adjusted Future 2035 AADT (1)
Big Bend Rd - Kracker Ave	21500	26690	25089	0.8570	-3589	46380	43597	37361	40009	38685
Kracker Ave - Ohio St	-	26378	24795			46307	43529	37302	39940	38621
Ohio St - Florence St	-	25964	24406			43710	41087	35210	37499	36355
Florence St - Symmes Rd	-	25964	24406			43710	41087	35210	37499	36355
Symmes Rd - Palm Ave	-	34052	32009	0.6695	-10861	60034	56432	37781	45571	41676
Palm Ave - Nundy Ave	-	34162	32112			60239	56625	37910	45763	41837
Nundy Ave - Gibsonton Dr	-	34272	32216			60444	56817	38039	45956	41998
Gibsonton Dr - Riverview Dr	-	35968	33810			69331	65171	43632	54310	48971
Riverview Dr - Madison Ave	22000	34959	32861			62234	58500	39166	47639	43402
Madison Ave - Port Sutton Rd	-	37515	35264	0.7931	-9000	68165	64075	50818	55075	52946
Port Sutton Rd - Hartford St	-	40826	38376			71442	67155	53261	58155	55708
Hartford St - Causeway Blvd	34500	46277	43500			79616	74839	59355	65839	62597
North of Causeway Blvd	23000	26255	24680	0.9319	-1680	54617	51340	47846	49660	48753

(1) Since only one set of volumes will be developed for the No-Build and the Build conditions, 2035 BUILD Model outputs have been used as they are conservative.

(1) is Average of (4) and (5)

(2) Same ratios and differences between base year counts and volumes have been applied to the segments along US 41: Big Bend Road - Symmes Road; Symmes Road - Madison Avenue; Madison Avenue - Causeway Boulevard and North of Causeway Boulevard. These segments are based on grouping similar existing and base year AADTs. 2006 Counts along US 41 that are within these segments have been used for the ratio and the difference method.

(4) = (3) \* (2006 Count/2006 Model AADT)

(5) = (3) + (2006 Count - 2006 Model AADT)



US 41 PD&E Study From Kracker Avenue to Causeway Boulevard

Major Side-Streets - Adjustment of 2035 Build Model Volumes per NCHRP 255 (Ratio and Difference) Method

REVISED per FDOT Comments received May 15, 2013

Segment along Major Side-Streets on US 41	2006 Counts	2006 Model Volume (PSWADT)	2006 Model AADT (=PSWADT*MOCF) MOCF=0.94	2006 Count/2006 Model AADT (2)	2006 Count - 2006 Model AADT (2)	2035 Build Model Volume (PSWADT)	2035 Build Model AADT (=PSWADT*MOCF) MOCF=0.94 (3)	Ratio Method Adjusted 2035 Future Traffic (4)	Difference Method Adjusted 2035 Future Traffic (5)	NCHRP 255 Adjusted Future 2035 AADT (1)
Causeway Blvd - West of US 41	29500	36731	34527	0.8544	-5027	68042	63959	54647	58932	56790
Causeway Blvd - East of US 41	27500	20734	19490	1.4110	8010	46438	43652	61592	51662	56627
Madison Ave - East of US 41**	12500	11218	10545	1.1854	1955	15265	14349	17009	16304	16657
Riverview Dr - East of US 41	7300	4085	3840	1.9011	3460	12564	11810	22452	15270	18861
Gibson Dr - East of US 41	18000	12098	11372	1.5828	6628	18818	17689	27998	24317	26158
Symmes Rd - East of US 41	7700	10135	9527	0.8082	-1827	18892	17758	14353	15932	15142

(1) Since only one set of volumes will be developed for the No-Build and the Build conditions, 2035 BUILD Model outputs have been used as they are conservative.

(1) is Average of (4) and (5)

(2) Ratios and Differences

(4) = (3) X (2006 Count/2006 Model AADT)

(5) = (3) + (2006 Count - 2006 Model AADT)

\*\*In the 2035 TBRPM Model Network, there is a new road connecting to US 41 north of Madison Avenue that reduces traffic on Madison Avenue to the east of US 41. Since this new road is not a part of the US 41 PD&E Study, the 2035 build model volume on Madison Avenue to the east of US 41 shown in the above table includes the traffic along the new road also.

US 41 PD&E Study From Kracker Avenue to Causeway Boulevard

Growth Rate for Minor Side-Streets along US 41 and Minor approaches of Major Side-Streets

Minor Side-streets along US 41	TAZ	2006			2035			Growth Rate			Combined Growth Rate
		Dwelling Unit	Population	Total Employment	Dwelling Unit	Population	Total Employment	Dwelling Unit	Population	Total Employment	
Hartford Street	683	346	890	1520	739	1640	2173	3.92%	2.91%	1.48%	2.77%
Port Sutton Road	682	13	40	1169	25	56	1462	3.18%	1.38%	0.86%	1.81%
Nundy Avenue	701	190	420	115	327	725	585	2.49%	2.50%	14.09%	6.36%
Palm Avenue, Florence Street, Ohio Street	700	766	1830	522	1116	2477	1048	1.58%	1.22%	3.47%	2.09%
Kracker Avenue	710	1509	4520	755	2955	6561	1118	3.30%	1.56%	1.66%	2.17%
<b>Average</b>											3.04%
<b>Minor Approaches of the Major Side-Streets</b>											
Madison Avenue - West of US 41	682	13	40	1169	25	56	1462	3.18%	1.38%	0.86%	1.81%
Riverview Dr - West of US 41	685	44	100	236	55	123	379	0.86%	0.79%	2.09%	1.25%
Gibson Dr - West of US 41	700	766	1830	522	1116	2477	1048	1.58%	1.22%	3.47%	2.09%
Symmes Rd - West of US 41	700	766	1830	522	1116	2477	1048	1.58%	1.22%	3.47%	2.09%
<b>Average</b>											1.81%

Recommended Growth Rate for Minor Side-Streets for Future Traffic Forecasting = 3.04%

Recommended Growth Rate for Minor Approaches of the Major Side-Streets for Future Traffic Forecasting = 1.81%

US 41 PD&E Study From Kracker Avenue to Causeway Boulevard  
Historical Trend Analyses

FDOT Count Station	Description	Trend R-squared	Trend Growth Rate (2011 to Design Year)
105258	US 41 - South of Madison Avenue	64.71%	2.35%
105346	US 41 - North of Big Bend Road	63.96%	3.01%
100051	US 41 - South of Big Bend Road	46.29%	2.62%
<b>US 41 Average</b>			<b>2.66%</b>
100033	Causeway Boulevard - West of US 41	55.07%	1.76%

Trend Analyses based on historical data obtained from FDOT FTI 2011 DVD.

# Tampa Bay Regional Planning Model 7.1 Base Year 2006 - US 41 PD&E Study - TAZ map

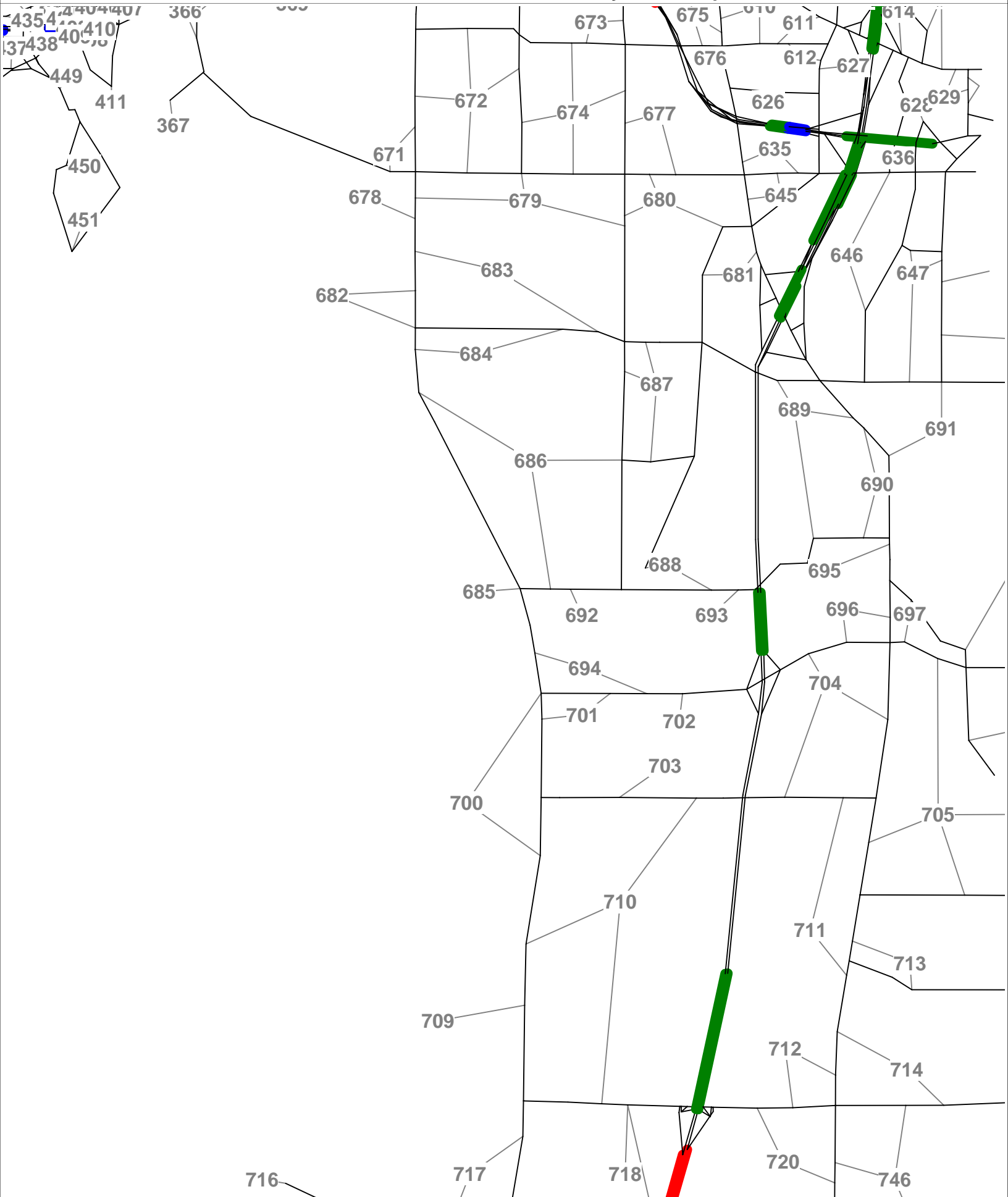

**Volume and Counts**

**Tampa Bay Regional Planning Model 7.1  
Base Year 2006 with Subarea Validation Refinements**

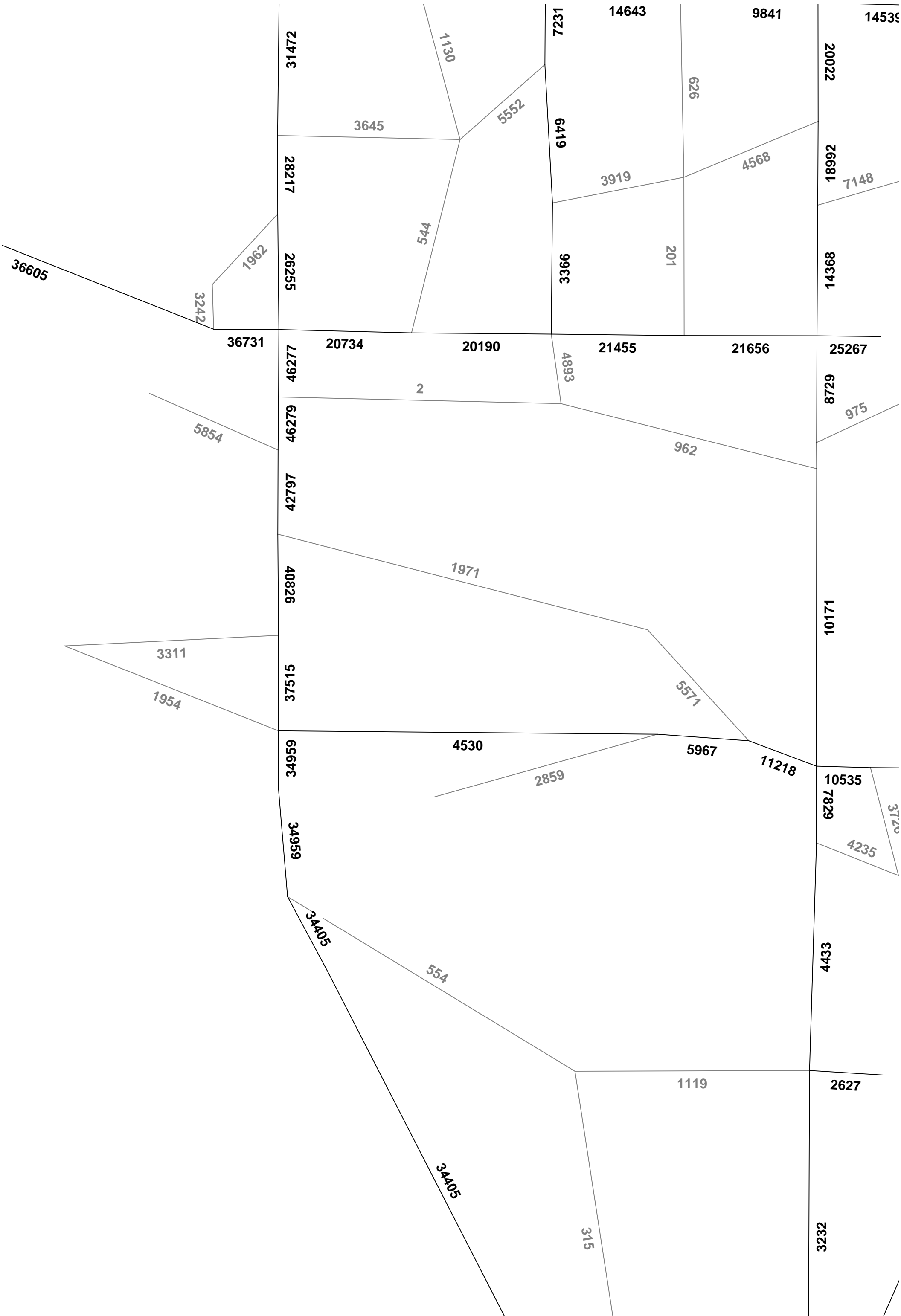

**Volume and Counts**

Tampa Bay Regional Planning Model 7.1  
Base Year 2006 with Subarea Validation Refinements

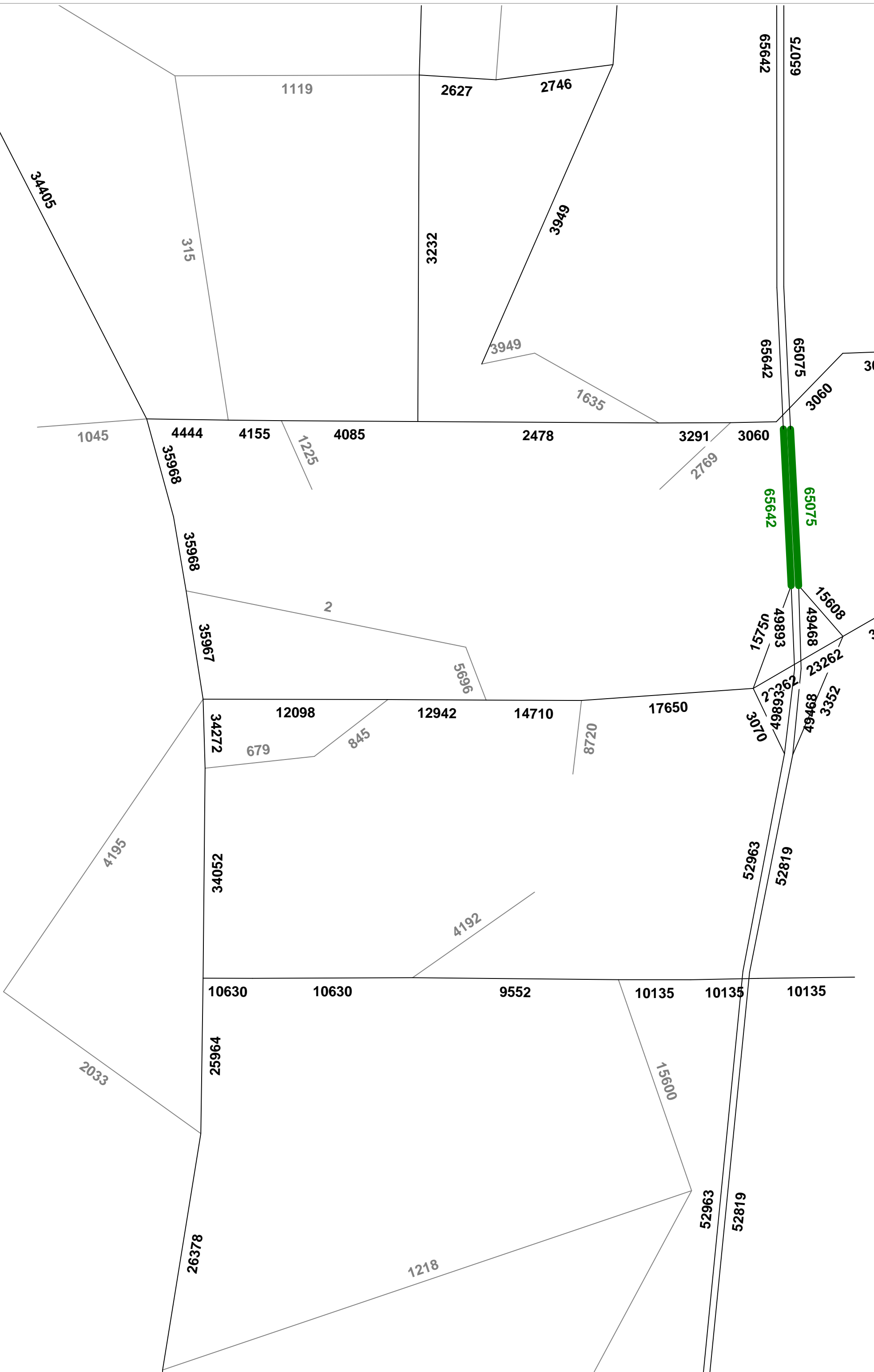

Volume and Counts

Tampa Bay Regional Planning Model 7.1  
Base Year 2006 with Subarea Validation Refinements

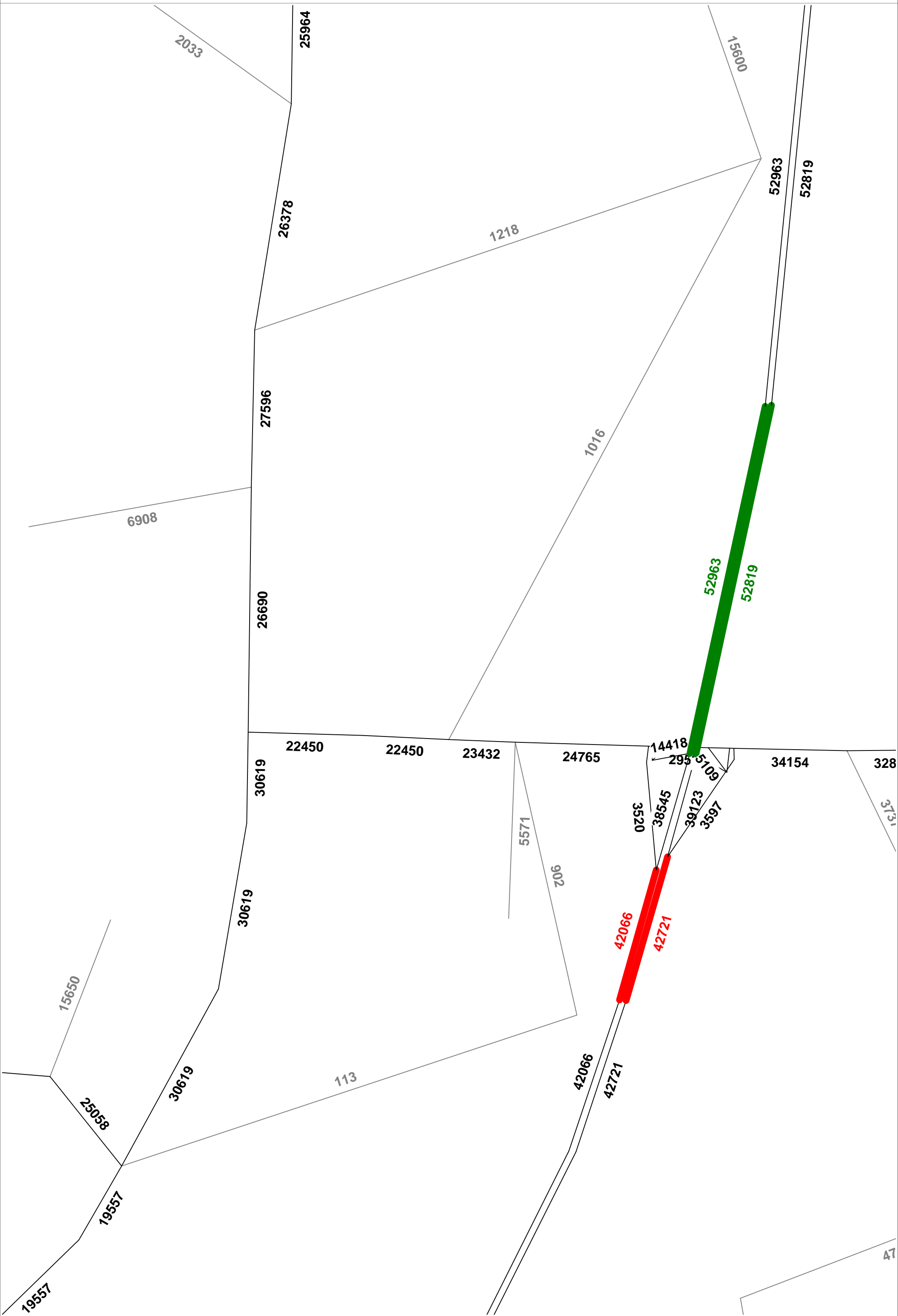

Volume and Counts

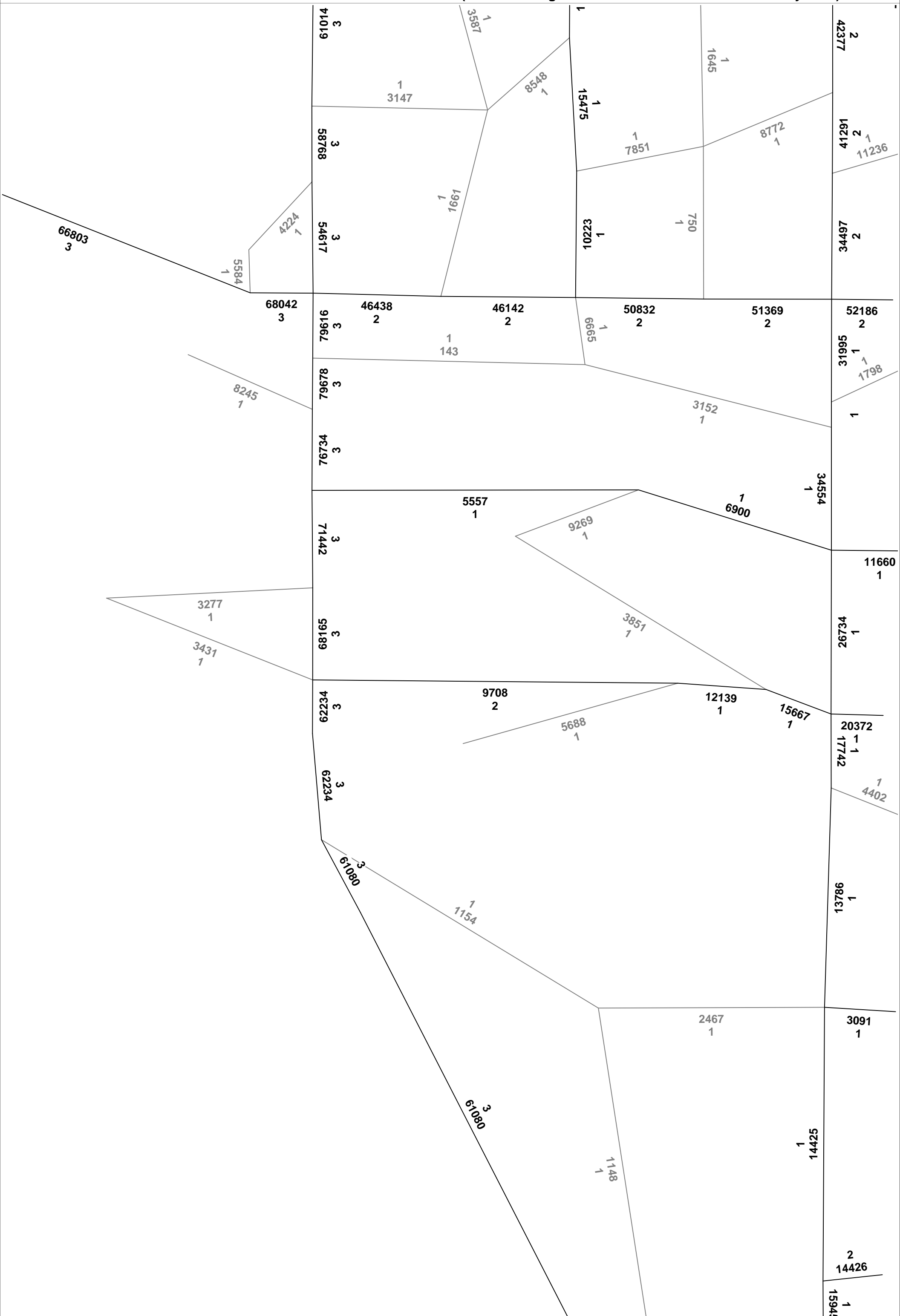

Volume and Counts



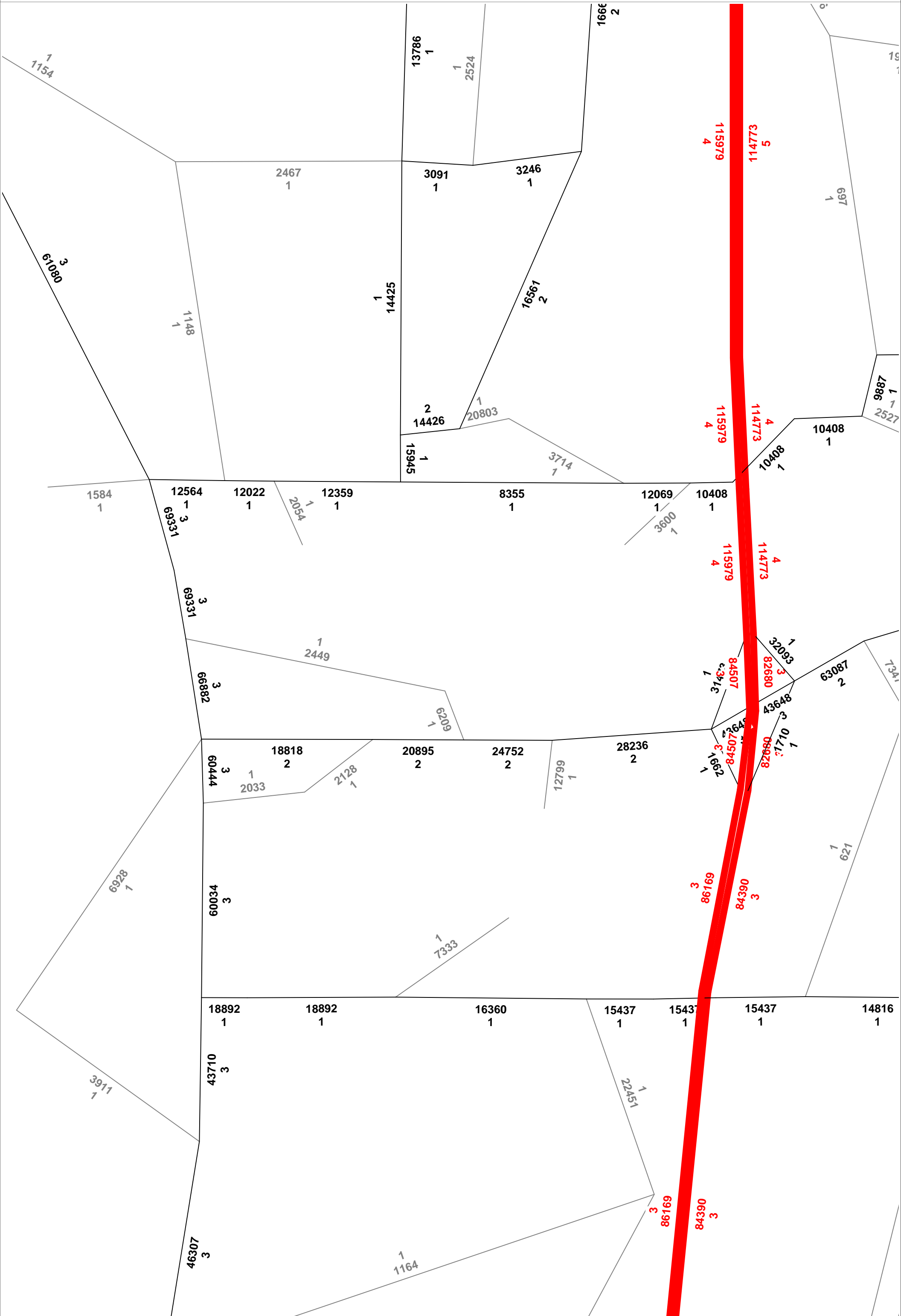

Volume and Counts

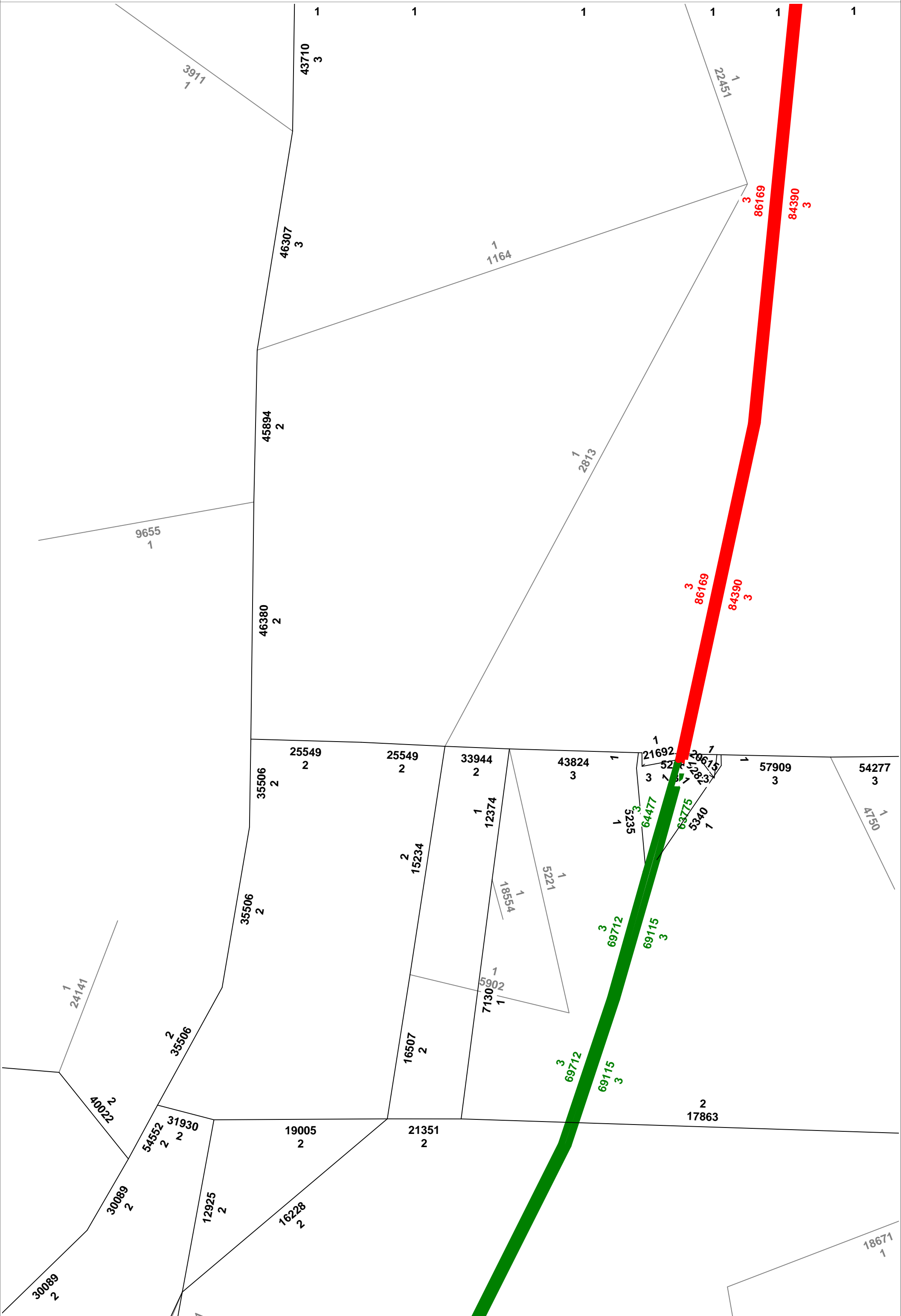

Volume and Counts

Tampa Bay Regional Planning Model 7.1  
Future Year 2035 with Subarea Validation Refinements - No Build

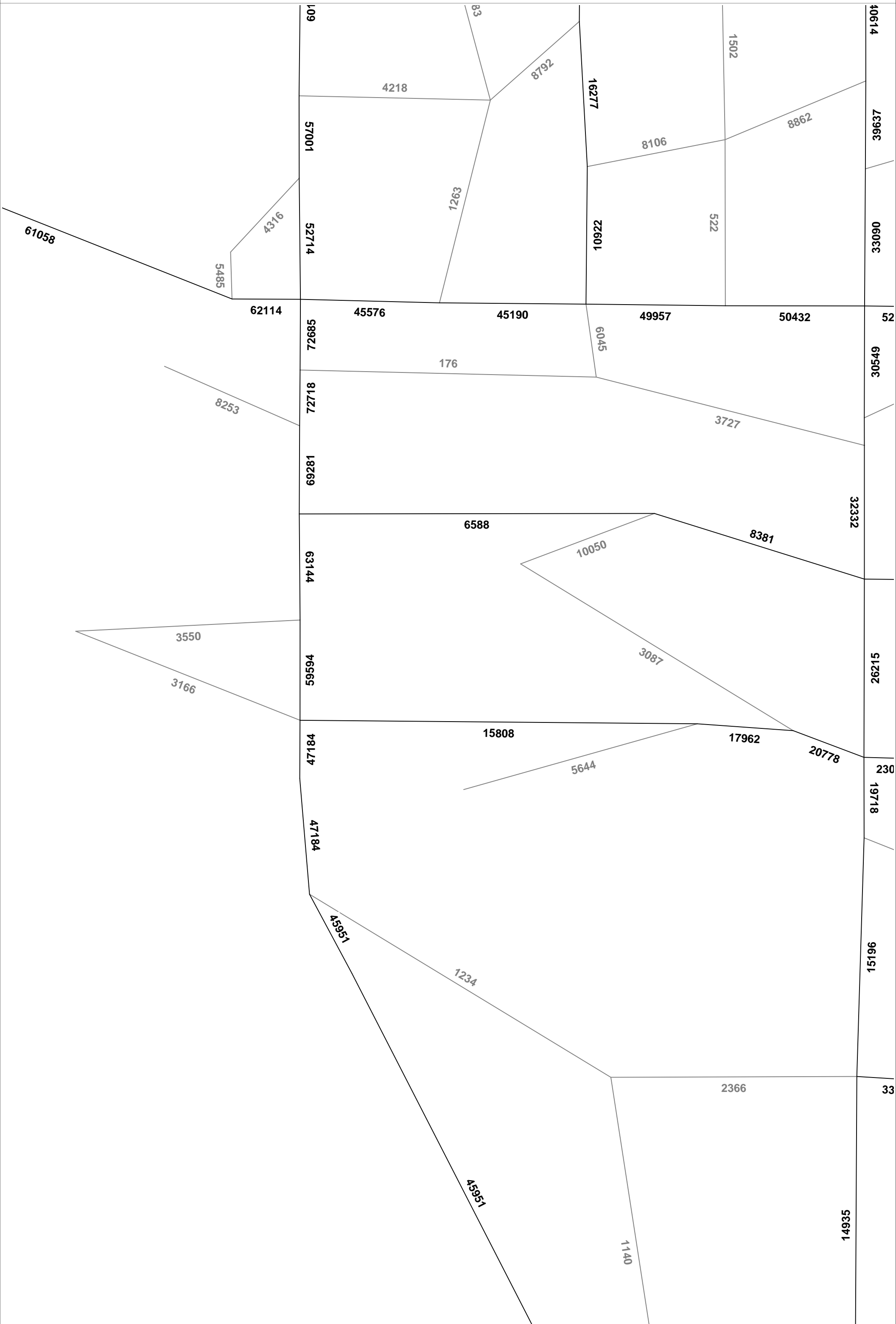

Tampa Bay Regional Planning Model 7.1  
 Future Year 2035 with Subarea Validation Refinements - No Build

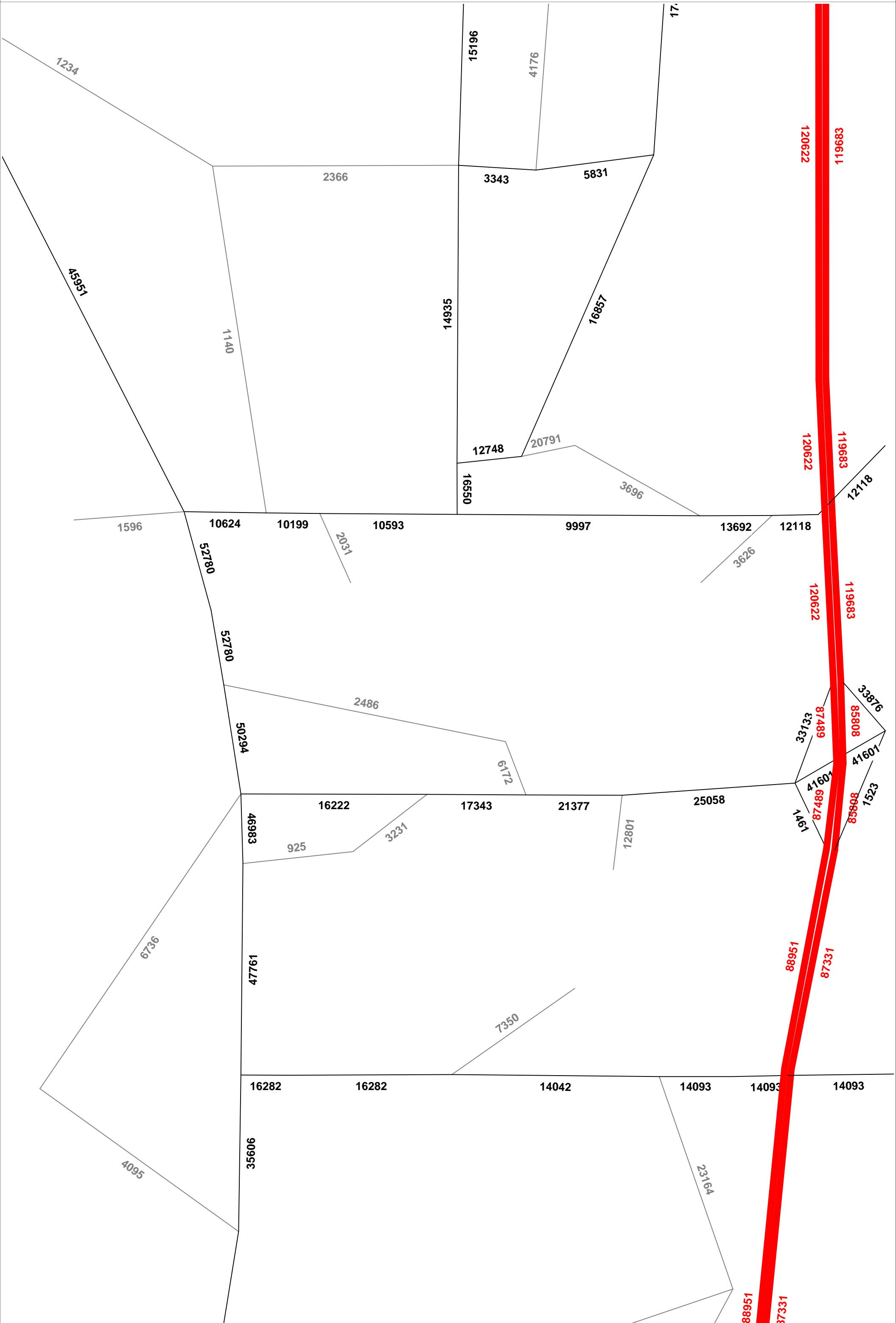

Tampa Bay Regional Planning Model 7.1  
Future Year 2035 with Subarea Validation Refinements - No Build

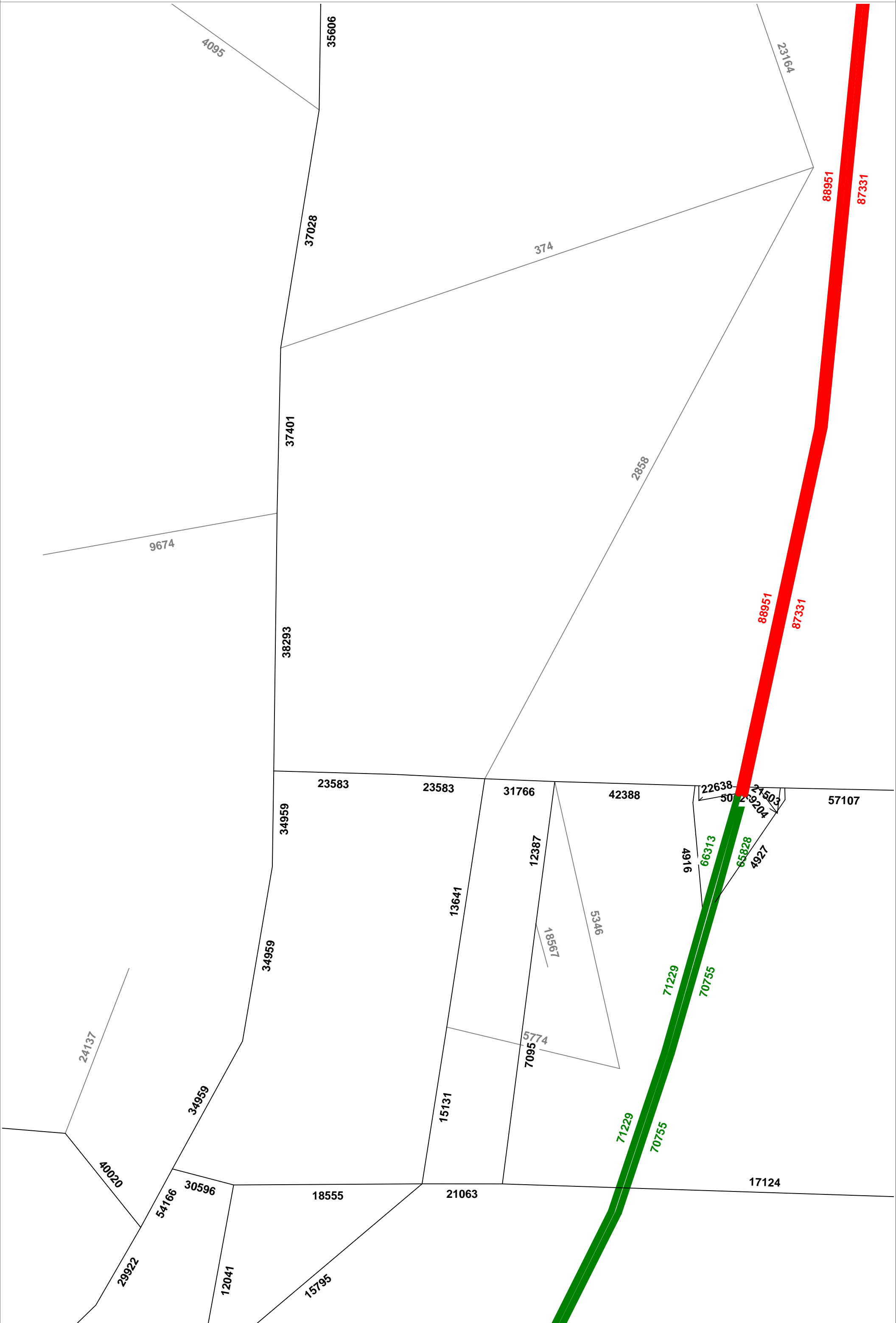

Florida Department of Transportation  
 Transportation Statistics Office  
 2011 Historical AADT Report

County: 10 - HILLSBOROUGH

Site: 5258 - SR 45/US 41/S 50TH ST, SOUTH OF CR 676A/MADISON AVE

Year	AADT		Direction 1	Direction 2	*K Factor	D Factor	T Factor
----	-----		-----	-----	-----	-----	-----
2011	25000	C	N 12000	S 13000	9.00	57.20	9.60
2010	24500	C	N 12000	S 12500	9.51	56.00	10.40
2009	24000	C	N 11500	S 12500	9.54	55.72	11.10
2008	24500	C	N 12000	S 12500	9.13	55.29	8.40
2007	25000	C	N 12500	S 12500	9.52	56.79	11.90
2006	21000	C	N 9000	S 12000	9.41	55.29	15.70
2005	23500	C	N 11500	S 12000	9.70	55.90	15.50
2004	21500	C	N 10500	S 11000	8.60	54.00	15.50
2003	18300	C	N 9000	S 9300	9.80	58.50	15.10
2002	21000	F	N 10500	S 10500	9.80	55.20	6.90
2001	20000	C	N 10000	S 10000	9.20	53.50	12.20
2000	18800	C	N 9300	S 9500	9.60	55.00	16.80
1999	19700	C	N 9800	S 9900	10.40	54.60	11.70
1998	18700	C	N 9300	S 9400	9.90	54.40	9.60
1997	19800	C	N 10000	S 9800	9.50	59.50	8.90
1996	17700	C	N 9200	S 8500	9.70	60.20	7.10

AADT Flags: C = Computed; E = Manual Estimate; F = First Year Estimate  
 S = Second Year Estimate; T = Third Year Estimate; X = Unknown  
 \*K Factor: Starting with Year 2011 is StandardK, Prior years are K30 values

## Traffic Trends - V2.0

### US 41 -- S. of Madison Ave

PIN#	XXXXXX-X
Location	5

County:	Hillsborough (10)
Station #:	5258
Highway:	US 41

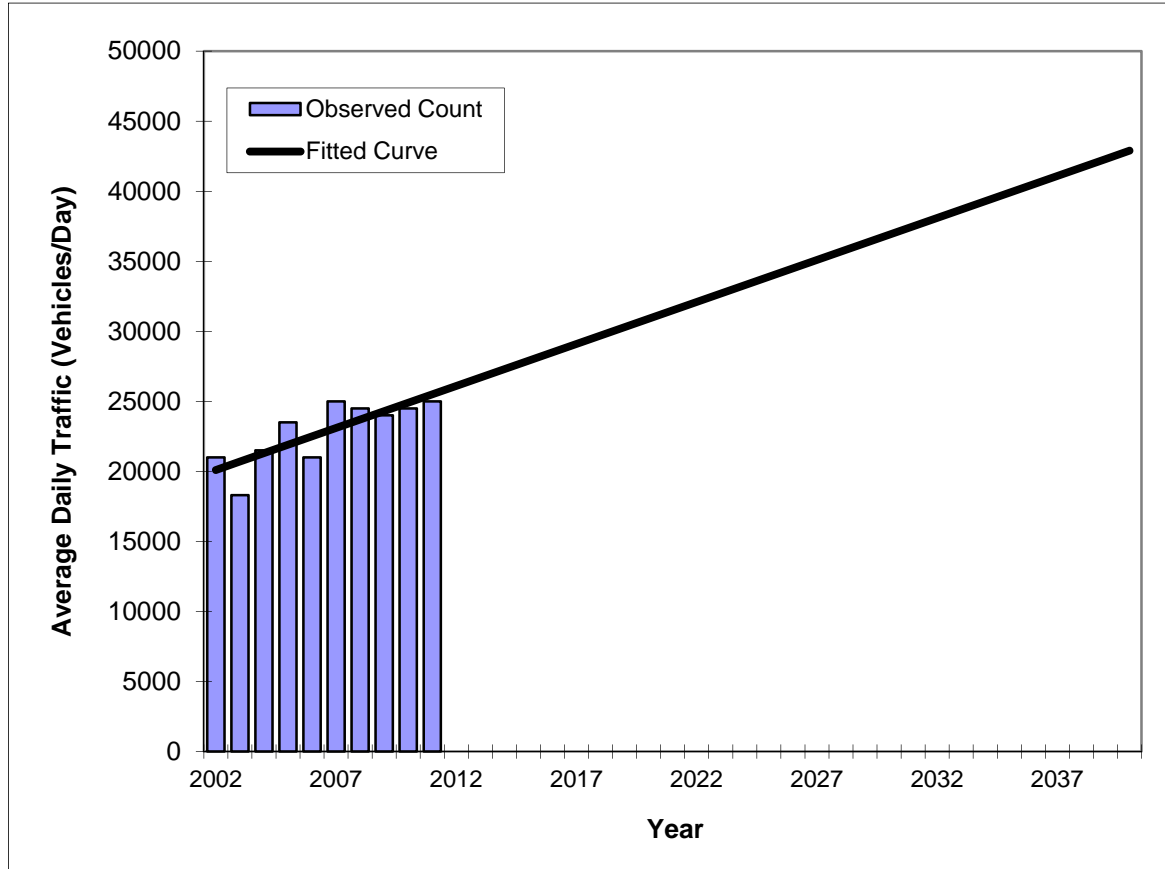

Year	Traffic (ADT/AADT)	
	Count*	Trend**
2002	21000	20100
2003	18300	20700
2004	21500	21300
2005	23500	21900
2006	21000	22500
2007	25000	23100
2008	24500	23700
2009	24000	24300
2010	24500	24900
2011	25000	25500
<b>2020 Opening Year Trend</b>		
2020	N/A	30900
<b>2030 Mid-Year Trend</b>		
2030	N/A	36900
<b>2040 Design Year Trend</b>		
2040	N/A	42900
<b>TRANPLAN Forecasts/Trends</b>		

** Annual Trend Increase:	599
Trend R-squared:	64.71%
Trend Annual Historic Growth Rate:	2.99%
Trend Growth Rate (2011 to Design Year):	2.35%
Printed:	19-Apr-13
<b>Straight Line Growth Option</b>	

\*Axle-Adjusted

Florida Department of Transportation  
 Transportation Statistics Office  
 2011 Historical AADT Report

County: 10 - HILLSBOROUGH

Site: 5346 - SR 45/US 41, NORTH OF CR 672/BIG BEND ROAD

Year	AADT		Direction 1	Direction 2	*K Factor	D Factor	T Factor
----	-----		-----	-----	-----	-----	-----
2011	21000 C	N	10500	S 10500	9.00	57.20	7.80
2010	21000 C	N	10500	S 10500	9.51	56.00	9.50
2009	21000 C	N	10500	S 10500	9.54	55.72	10.30
2008	21000 C	N	10500	S 10500	9.13	55.29	12.80
2007	23000 C	N	11500	S 11500	9.52	56.79	11.30
2006	20500 C	N	10500	S 10000	9.41	55.29	13.20
2005	18900 C	N	10500	S 8400	9.70	55.90	12.70
2004	18100 C	N	9200	S 8900	8.60	54.00	12.70
2003	14700 C	N	7800	S 6900	9.80	58.50	13.80
2002	16000 F	N	7800	S 8200	9.80	55.20	6.90
2001	15600 C	N	7600	S 8000	9.20	53.50	10.80
2000	14100 C	N	7100	S 7000	9.60	55.00	10.90
1999	15400 F	N	7500	S 7900	10.40	54.60	12.90
1998	14800 C	N	7200	S 7600	9.90	54.40	11.50
1997	13700 C	N	6900	S 6800	9.50	59.50	10.70
1996	13600 C	N	6900	S 6700	9.70	60.20	8.70

AADT Flags: C = Computed; E = Manual Estimate; F = First Year Estimate  
 S = Second Year Estimate; T = Third Year Estimate; X = Unknown  
 \*K Factor: Starting with Year 2011 is StandardK, Prior years are K30 values



## Traffic Trends - V2.0

### US 41 -- N. of Big Bend Rd

PIN#	XXXXXX-X
Location	6

County:	Hillsborough (10)
Station #:	5346
Highway:	US 41

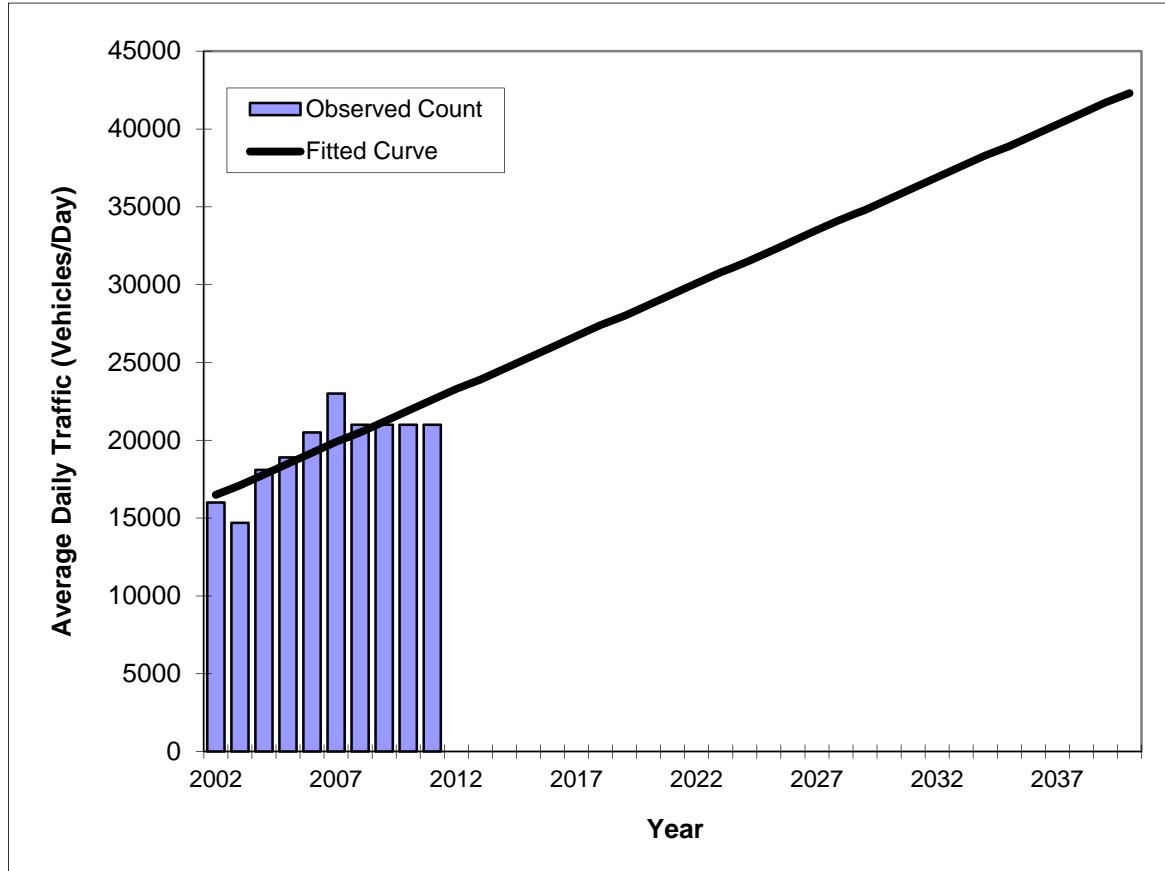

Year	Traffic (ADT/AADT)	
	Count*	Trend**
2002	16000	16500
2003	14700	17100
2004	18100	17800
2005	18900	18500
2006	20500	19200
2007	23000	19900
2008	21000	20500
2009	21000	21200
2010	21000	21900
2011	21000	22600
<b>2020 Opening Year Trend</b>		
2020	N/A	28700
<b>2030 Mid-Year Trend</b>		
2030	N/A	35500
<b>2040 Design Year Trend</b>		
2040	N/A	42300
<b>TRANPLAN Forecasts/Trends</b>		

** Annual Trend Increase:	681
Trend R-squared:	63.96%
Trend Annual Historic Growth Rate:	4.11%
Trend Growth Rate (2011 to Design Year):	3.01%
Printed:	19-Apr-13
<b>Straight Line Growth Option</b>	

\*Axle-Adjusted

Florida Department of Transportation  
 Transportation Statistics Office  
 2011 Historical AADT Report

County: 10 - HILLSBOROUGH

Site: 0051 - SR 45/US 41, SOUTH OF CR 672/BIG BEND ROAD

Year	AADT	Direction 1	Direction 2	*K Factor	D Factor	T Factor
2011	27000 C	N 14000	S 13000	9.00	57.20	8.60
2010	27000 C	N 13500	S 13500	9.51	56.00	9.40
2009	25000 C	N 13000	S 12000	9.54	55.72	6.50
2008	25500 C	N 13000	S 12500	9.13	55.29	6.50
2007	31500 C	N 16000	S 15500	9.52	56.79	6.50
2006	26500 C	N 14000	S 12500	9.41	55.29	8.70
2005	24500 C	N 12500	S 12000	9.70	55.90	6.30
2004	21500 C	N 11000	S 10500	8.60	54.00	6.30
2003	20800 C	N 11000	S 9800	9.80	58.50	9.00
2002	21000 C	N 11000	S 10000	9.80	55.20	7.60
2001	20200 C	N 10500	S 9700	9.20	53.50	7.60
2000	18700 C	N 9600	S 9100	9.60	55.00	8.10
1999	19300 C	N 9900	S 9400	10.40	54.60	9.10
1998	18800 C	N 9500	S 9300	9.90	54.40	7.70
1997	18100 C	N 9400	S 8700	9.50	59.50	7.10
1996	17300 C	N 8900	S 8400	9.70	60.20	5.50

AADT Flags: C = Computed; E = Manual Estimate; F = First Year Estimate  
 S = Second Year Estimate; T = Third Year Estimate; X = Unknown  
 \*K Factor: Starting with Year 2011 is StandardK, Prior years are K30 values

## Traffic Trends - V2.0

### US 41 -- S. of Big Bend Rd

PIN#	XXXXXX-X
Location	4

County:	Hillsborough (10)
Station #:	0051
Highway:	US 41

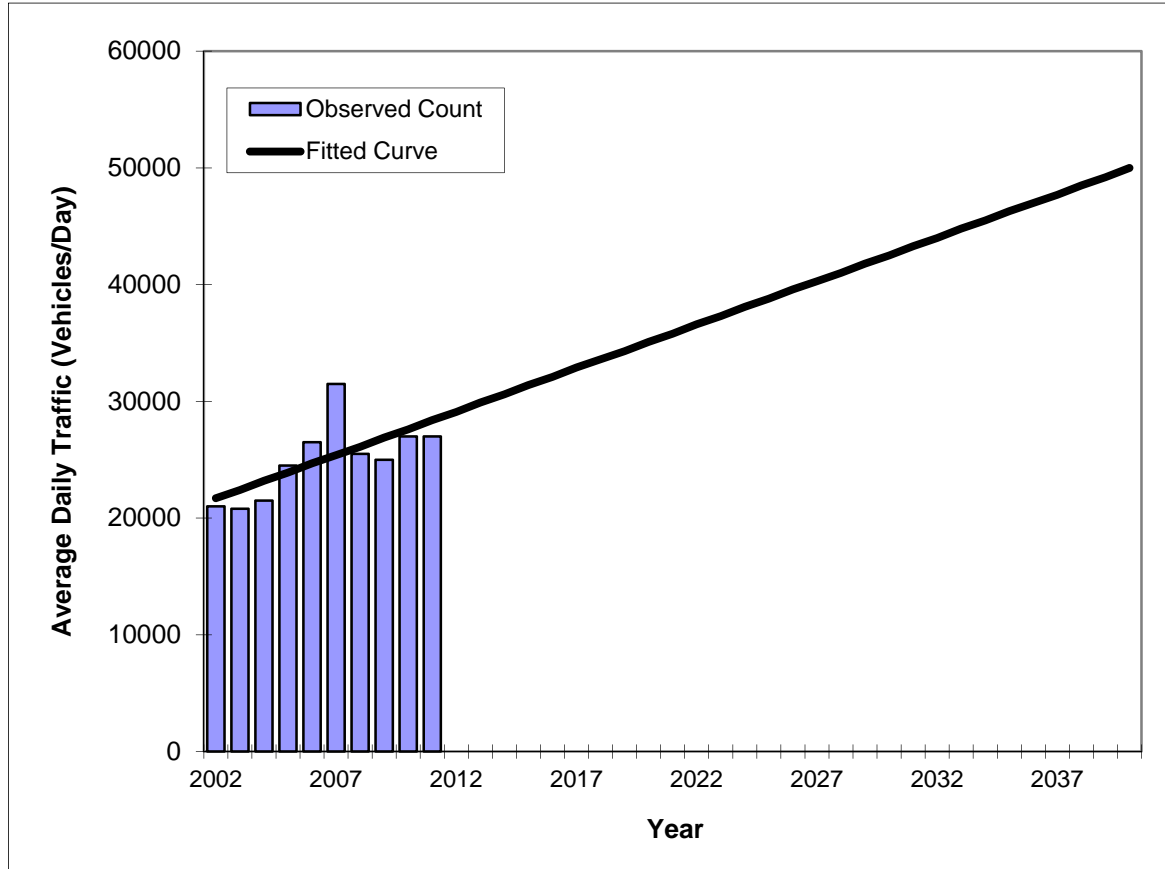

Year	Traffic (ADT/AADT)	
	Count*	Trend**
2002	21000	21700
2003	20800	22400
2004	21500	23200
2005	24500	23900
2006	26500	24700
2007	31500	25400
2008	25500	26100
2009	25000	26900
2010	27000	27600
2011	27000	28400
<b>2020 Opening Year Trend</b>		
2020	N/A	35100
<b>2030 Mid-Year Trend</b>		
2030	N/A	42500
<b>2040 Design Year Trend</b>		
2040	N/A	50000
<b>TRANPLAN Forecasts/Trends</b>		

** Annual Trend Increase:	745
Trend R-squared:	46.29%
Trend Annual Historic Growth Rate:	3.43%
Trend Growth Rate (2011 to Design Year):	2.62%
Printed:	19-Apr-13
<b>Straight Line Growth Option</b>	

\*Axle-Adjusted

Florida Department of Transportation  
 Transportation Statistics Office  
 2011 Historical AADT Report

County: 10 - HILLSBOROUGH

Site: 0033 - SR 45/USB 41/22ND ST CAUSEWAY, W OF US 41/SR 45

Year	AADT	Direction 1	Direction 2	*K Factor	D Factor	T Factor
2011	28500 C	E 13500	W 15000	9.00	57.20	11.00
2010	27500 C	E 13500	W 14000	9.51	56.00	11.00
2009	25500 C	E 13000	W 12500	9.54	55.72	8.80
2008	25500 C	E 12500	W 13000	9.13	55.29	6.40
2007	27500 C	E 14000	W 13500	9.52	56.79	10.70
2006	28000 C	E 14500	W 13500	9.41	55.29	17.20
2005	27000 C	E 14000	W 13000	9.70	55.90	4.40
2004	24500 S	E 12500	W 12000	8.60	54.00	15.40
2003	23500 F	E 12000	W 11500	9.80	58.50	15.40
2002	22500 C	E 11500	W 11000	9.80	55.20	15.40
2001	24500 C	E 12500	W 12000	9.20	53.50	13.90
2000	23000 C	E 11000	W 12000	9.60	55.00	19.60
1999	25500 C	E 12500	W 13000	10.40	54.60	15.20
1998	23500 C	E 12500	W 11000	9.90	54.40	15.50
1997	23000 F	E 11500	W 11500	9.50	59.50	13.80
1996	22000 C	E 11000	W 11000	9.70	60.20	9.70

AADT Flags: C = Computed; E = Manual Estimate; F = First Year Estimate  
 S = Second Year Estimate; T = Third Year Estimate; X = Unknown  
 \*K Factor: Starting with Year 2011 is StandardK, Prior years are K30 values

## Traffic Trends - V2.0

### CAUSEWAY BLVD -- W. of US 41

PIN#	XXXXXX-X
Location	3

County:	Hillsborough (10)
Station #:	0033
Highway:	CAUSEWAY BLVD

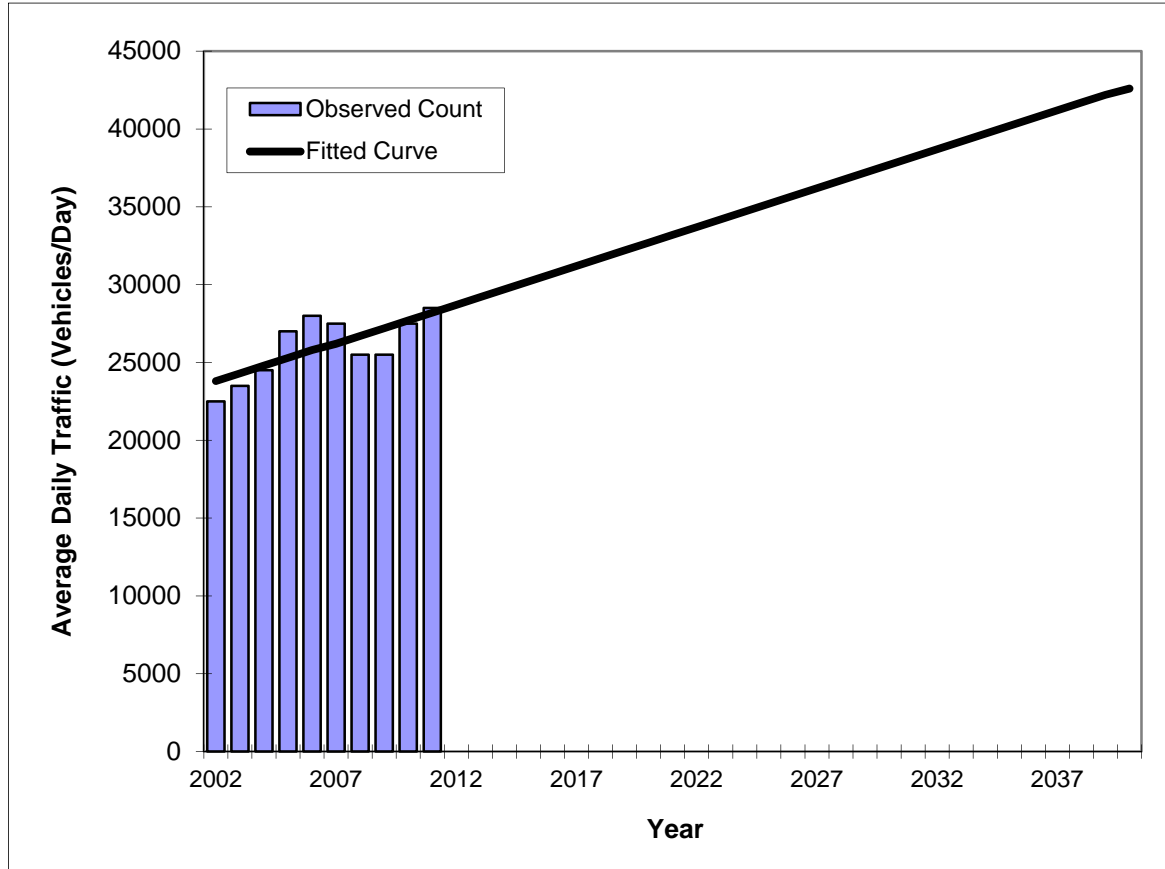

Year	Traffic (ADT/AADT)	
	Count*	Trend**
2002	22500	23800
2003	23500	24300
2004	24500	24800
2005	27000	25300
2006	28000	25800
2007	27500	26200
2008	25500	26700
2009	25500	27200
2010	27500	27700
2011	28500	28200
<b>2020 Opening Year Trend</b>		
2020	N/A	32700
<b>2030 Mid-Year Trend</b>		
2030	N/A	37700
<b>2040 Design Year Trend</b>		
2040	N/A	42600
<b>TRANPLAN Forecasts/Trends</b>		

** Annual Trend Increase:	497
Trend R-squared:	55.07%
Trend Annual Historic Growth Rate:	2.05%
Trend Growth Rate (2011 to Design Year):	1.76%
Printed:	19-Apr-13
<b>Straight Line Growth Option</b>	

\*Axle-Adjusted

## **APPENDIX H**

# **CALCULATION OF FUTURE YEAR DIRECTIONAL DESIGN HOUR VOLUMES AND AM AND PM TURNING TRAFFIC VOLUMES**

US 41 PD&E Study From Kracker Avenue to Causeway Boulevard

Future Year AADTs based on Interpolation and Extrapolation between Existing Year 2013 AADTs and Future Year 2035 Build Model Adjusted AADTs

Segment along US 41	2013 AADT	Future 2035 AADT*	2020 AADT	Rounded 2020 AADT	2030 AADT	Rounded 2030 AADT	2040 AADT	Rounded 2040 AADT
Big Bend Rd - Kracker Ave	22400	38685	27582	27600	34984	35000	42386	42400
Kracker Ave - Ohio St	23400	38621	28243	28250	35162	35150	42081	42100
Ohio St - Florence St	25550	36355	28988	29000	33899	33900	38810	38800
Florence St - Symmes Rd	24850	36355	28511	28500	33740	33750	38969	38975
Symmes Rd - Palm Ave	27050	41676	31704	31700	38352	38350	45000	45000
Palm Ave - Nundy Ave	29050	41837	33118	33100	38931	38925	44743	44750
Nundy Ave - Gibsonton Dr	27850	41998	32351	32350	38782	38800	45213	45200
Gibsonton Dr - Riverview Dr	28350	48971	34911	34900	44284	44300	53657	53650
Riverview Dr - Madison Ave	26650	43402	31980	32000	39595	39600	47209	47200
Madison Ave - Port Sutton Rd	32350	52946	38903	38900	48265	48250	57627	57625
Port Sutton Rd - Hartford St	32600	55708	39953	39950	50456	50450	60960	60950
Hartford St - Causeway Blvd	36400	62597	44735	44750	56643	56650	68551	68550
North of Causeway Blvd	23700	48753	31671	31675	43059	43050	54447	54450
<b>Major Side-Streets</b>								
Causeway Blvd - West of US 41	33000	56790	40569	40575	51383	51375	62196	62200
Causeway Blvd - East of US 41	21450	56627	32643	32650	48632	48650	64622	64625
Madison Ave - East of US 41	9100	16657	11504	11500	14939	14950	18374	18375
Riverview Dr - East of US 41	6150	18861	10194	10200	15972	15975	21750	21750
Gibsonton Dr - East of US 41	12500	26158	16846	16850	23054	23050	29262	29250
Symmes Rd - East of US 41	6650	15142	9352	9350	13212	13200	17072	17075

\*Based on Adjusted 2035 BUILD Model Volumes

US 41 PD&E Study From Kracker Avenue to Causeway Boulevard

Future Year AADTs along Side-Streets using annual growth rate

Side-Streets	2013 AADT	2020 AADT	Rounded 2020 AADT	2030 AADT	Rounded 2030 AADT	2040 AADT	Rounded 2040 AADT
Kracker Ave - E. of US 41	340	412	410	516	515	619	620
Kracker Ave - W. of US 41	240	291	290	364	365	437	435
Ohio St - E. of US 41	1450	1759	1760	2199	2200	2640	2640
Florence St - E. of US 41	270	327	325	410	410	492	490
Florence St - W. of US 41	400	485	485	607	605	728	730
Symmes Rd - W. of US 41*	100	113	115	131	130	149	150
Palm Ave - E. of US 41	500	606	605	758	760	910	910
Palm Ave - W. of US 41	570	691	690	865	865	1038	1040
Nundy Ave - E. of US 41	2050	2486	2500	3109	3100	3733	3730
Nundy Ave - W. of US 41	350	424	425	531	530	637	635
Gibsonston Dr - W. of US 41*	1100	1239	1240	1438	1440	1638	1640
Riverview Dr - W. of US 41*	1550	1746	1750	2027	2025	2307	2310
Madison Ave - W. of US 41*	1900	2141	2140	2485	2485	2829	2830
Port Sutton Rd - W. of US 41	1650	2001	2000	2503	2500	3004	3000
Hartford St - E. of US 41	1600	1940	1940	2427	2425	2913	2910
Hartford St - W. of US 41	270	327	325	410	410	492	490

Annual Growth Rate for Minor  
Side-Streets= 3.04%

\*Annual Growth Rate for Minor  
Approaches of Major Side-Streets= 1.81%



**US 41 PD&E - From Kracker Avenue to Causeway Boulevard**

**YEAR 2020 AM PEAK**

**Calculation of DDHVs from AADTs**

Traffic Count Location	2020 AADT	K	D-Peak	D-Off Peak	Peak DDHV	Off Peak DDHV
<b>US 41</b>						
South of Kracker Avenue	27600	9.00%	64.27%	35.73%	1596	888
Kracker Avenue - Ohio Street	28250	9.00%	64.27%	35.73%	1634	908
Ohio Street - Florence Street	29000	9.00%	64.27%	35.73%	1677	933
Florence Street - Symmes Road	28500	9.00%	64.27%	35.73%	1649	916
Symmes Road - Palm Avenue	31700	9.00%	64.27%	35.73%	1834	1019
Palm Avenue - Nundy Avenue	33100	9.00%	64.27%	35.73%	1915	1064
Nundy Avenue - Gibsonton Drive	32350	9.00%	64.27%	35.73%	1871	1040
Gibsonton Drive - Riverview Drive	34900	9.00%	64.27%	35.73%	2019	1122
Riverview Drive - Madison Avenue	32000	9.00%	64.27%	35.73%	1851	1029
Madison Avenue - Port Sutton Road	38900	9.00%	64.27%	35.73%	2250	1251
Port Sutton Road - Hartford Street	39950	9.00%	64.27%	35.73%	2311	1285
Hartford Street - Causeway Boulevard	44750	9.00%	64.27%	35.73%	2588	1439
North of Causeway Boulevard	31675	9.00%	64.27%	35.73%	1832	1019
<b>Kracker Avenue</b>						
East of US 41	410	9.00%	61.11%	38.89%	23	14
West of US 41	290	9.00%	53.33%	46.67%	14	12
<b>Ohio Street</b>						
East of US 41	1760	9.00%	63.64%	36.36%	101	58
<b>Florence Street</b>						
East of US 41	325	9.00%	60.00%	40.00%	18	12
West of US 41	485	9.00%	56.67%	43.33%	25	19
<b>Symmes Road</b>						
East of US 41	9350	9.00%	67.60%	32.40%	569	273
West of US 41	115	9.00%	91.67%	8.33%	9	1
<b>Palm Avenue</b>						
East of US 41	605	9.00%	60.00%	40.00%	33	22
West of US 41	690	9.00%	76.00%	24.00%	47	15
<b>Nundy Avenue</b>						
East of US 41	2500	9.00%	56.47%	43.53%	127	98
West of US 41	425	9.00%	61.90%	38.10%	24	15
<b>Gibsonton Drive/Alice Avenue</b>						
East of US 41	16850	9.00%	52.02%	47.98%	789	728
West of US 41	1240	9.00%	54.12%	45.88%	60	51
<b>Riverview Drive/Industrial Access Road</b>						
East of US 41	10200	9.00%	53.94%	46.06%	495	423
West of US 41	1750	9.00%	75.65%	24.35%	119	38
<b>Madison Avenue/Pendola Point Road</b>						
East of US 41	11500	9.00%	65.65%	34.35%	679	356
West of US 41	2140	9.00%	60.00%	40.00%	116	77
<b>Port Sutton Road</b>						
West of US 41	2000	9.00%	71.74%	28.26%	129	51
<b>Hartford Street</b>						
East of US 41	1940	9.00%	55.47%	44.53%	97	78
West of US 41	325	9.00%	80.77%	19.23%	24	6
<b>Causeway Boulevard</b>						
East of US 41	32650	9.00%	72.06%	27.94%	2117	821
West of US 41	40575	9.00%	77.98%	22.02%	2848	804

**US 41 PD&E - From Kracker Avenue to Causeway Boulevard**

**YEAR 2020 PM PEAK**

**Calculation of DDHVs from AADTs**

Traffic Count Location	2020 AADT	K	D-Peak	D-Off Peak	Peak DDHV	Off Peak DDHV
<b>US 41</b>						
South of Kracker Avenue	27600	9.00%	64.27%	35.73%	1596	888
Kracker Avenue - Ohio Street	28250	9.00%	64.27%	35.73%	1634	908
Ohio Street - Florence Street	29000	9.00%	64.27%	35.73%	1677	933
Florence Street - Symmes Road	28500	9.00%	64.27%	35.73%	1649	916
Symmes Road - Palm Avenue	31700	9.00%	64.27%	35.73%	1834	1019
Palm Avenue - Nundy Avenue	33100	9.00%	64.27%	35.73%	1915	1064
Nundy Avenue - Gibsonton Drive	32350	9.00%	64.27%	35.73%	1871	1040
Gibsonton Drive - Riverview Drive	34900	9.00%	64.27%	35.73%	2019	1122
Riverview Drive - Madison Avenue	32000	9.00%	64.27%	35.73%	1851	1029
Madison Avenue - Port Sutton Road	38900	9.00%	64.27%	35.73%	2250	1251
Port Sutton Road - Hartford Street	39950	9.00%	64.27%	35.73%	2311	1285
Hartford Street - Causeway Boulevard	44750	9.00%	64.27%	35.73%	2588	1439
North of Causeway Boulevard	31675	9.00%	64.27%	35.73%	1832	1019
<b>Kracker Avenue</b>						
East of US 41	410	9.00%	54.17%	45.83%	20	17
West of US 41	290	9.00%	69.23%	30.77%	18	8
<b>Ohio Street</b>						
East of US 41	1760	9.00%	70.43%	29.57%	112	47
<b>Florence Street</b>						
East of US 41	325	9.00%	55.56%	44.44%	16	13
West of US 41	485	9.00%	51.22%	48.78%	22	21
<b>Symmes Road</b>						
East of US 41	9350	9.00%	70.14%	29.86%	590	251
West of US 41	115	9.00%	83.33%	16.67%	9	2
<b>Palm Avenue</b>						
East of US 41	605	9.00%	64.47%	35.53%	35	19
West of US 41	690	9.00%	51.06%	48.94%	32	30
<b>Nundy Avenue</b>						
East of US 41	2500	9.00%	55.42%	44.58%	125	100
West of US 41	425	9.00%	51.43%	48.57%	20	19
<b>Gibsonton Drive/Alice Avenue</b>						
East of US 41	16850	9.00%	66.24%	33.76%	1005	512
West of US 41	1240	9.00%	60.92%	39.08%	68	44
<b>Riverview Drive/Industrial Access Road</b>						
East of US 41	10200	9.00%	59.96%	40.04%	550	368
West of US 41	1750	9.00%	75.25%	24.75%	119	39
<b>Madison Avenue/Pendola Point Road</b>						
East of US 41	11500	9.00%	67.28%	32.72%	696	339
West of US 41	2140	9.00%	83.33%	16.67%	160	32
<b>Port Sutton Road</b>						
West of US 41	2000	9.00%	87.88%	12.12%	158	22
<b>Hartford Street</b>						
East of US 41	1940	9.00%	52.25%	47.75%	91	83
West of US 41	325	9.00%	61.11%	38.89%	18	11
<b>Causeway Boulevard</b>						
East of US 41	32650	9.00%	67.79%	32.21%	1992	946
West of US 41	40575	9.00%	73.11%	26.89%	2670	982

**US 41 PD&E - From Kracker Avenue to Causeway Boulevard**

**YEAR 2030 AM PEAK**

**Calculation of DDHVs from AADTs**

Traffic Count Location	2030 AADT	K	D-Peak	D-Off Peak	Peak DDHV	Off Peak DDHV
<b>US 41</b>						
South of Kracker Avenue	35000	9.00%	64.27%	35.73%	2025	1125
Kracker Avenue - Ohio Street	35150	9.00%	64.27%	35.73%	2033	1130
Ohio Street - Florence Street	33900	9.00%	64.27%	35.73%	1961	1090
Florence Street - Symmes Road	33750	9.00%	64.27%	35.73%	1952	1085
Symmes Road - Palm Avenue	38350	9.00%	64.27%	35.73%	2218	1233
Palm Avenue - Nundy Avenue	38925	9.00%	64.27%	35.73%	2252	1252
Nundy Avenue - Gibsonton Drive	38800	9.00%	64.27%	35.73%	2244	1248
Gibsonton Drive - Riverview Drive	44300	9.00%	64.27%	35.73%	2562	1425
Riverview Drive - Madison Avenue	39600	9.00%	64.27%	35.73%	2291	1273
Madison Avenue - Port Sutton Road	48250	9.00%	64.27%	35.73%	2791	1552
Port Sutton Road - Hartford Street	50450	9.00%	64.27%	35.73%	2918	1622
Hartford Street - Causeway Boulevard	56650	9.00%	64.27%	35.73%	3277	1822
North of Causeway Boulevard	43050	9.00%	64.27%	35.73%	2490	1384
<b>Kracker Avenue</b>						
East of US 41	515	9.00%	61.11%	38.89%	28	18
West of US 41	365	9.00%	53.33%	46.67%	18	15
<b>Ohio Street</b>						
East of US 41	2200	9.00%	63.64%	36.36%	126	72
<b>Florence Street</b>						
East of US 41	410	9.00%	60.00%	40.00%	22	15
West of US 41	605	9.00%	56.67%	43.33%	31	24
<b>Symmes Road</b>						
East of US 41	13200	9.00%	67.60%	32.40%	803	385
West of US 41	130	9.00%	91.67%	8.33%	11	1
<b>Palm Avenue</b>						
East of US 41	760	9.00%	60.00%	40.00%	41	27
West of US 41	865	9.00%	76.00%	24.00%	59	19
<b>Nundy Avenue</b>						
East of US 41	3100	9.00%	56.47%	43.53%	158	121
West of US 41	530	9.00%	61.90%	38.10%	30	18
<b>Gibsonton Drive/Alice Avenue</b>						
East of US 41	23050	9.00%	52.02%	47.98%	1079	995
West of US 41	1440	9.00%	54.12%	45.88%	70	59
<b>Riverview Drive/Industrial Access Road</b>						
East of US 41	15975	9.00%	53.94%	46.06%	776	662
West of US 41	2025	9.00%	75.65%	24.35%	138	44
<b>Madison Avenue/Pendola Point Road</b>						
East of US 41	14950	9.00%	65.65%	34.35%	883	462
West of US 41	2485	9.00%	60.00%	40.00%	134	89
<b>Port Sutton Road</b>						
West of US 41	2500	9.00%	71.74%	28.26%	161	64
<b>Hartford Street</b>						
East of US 41	2425	9.00%	55.47%	44.53%	121	97
West of US 41	410	9.00%	80.77%	19.23%	30	7
<b>Causeway Boulevard</b>						
East of US 41	48650	9.00%	72.06%	27.94%	3155	1223
West of US 41	51375	9.00%	77.98%	22.02%	3606	1018

**US 41 PD&E - From Kracker Avenue to Causeway Boulevard**

**YEAR 2030 PM PEAK**

**Calculation of DDHVs from AADTs**

Traffic Count Location	2030 AADT	K	D-Peak	D-Off Peak	Peak DDHV	Off Peak DDHV
<b>US 41</b>						
South of Kracker Avenue	35000	9.00%	64.27%	35.73%	2025	1125
Kracker Avenue - Ohio Street	35150	9.00%	64.27%	35.73%	2033	1130
Ohio Street - Florence Street	33900	9.00%	64.27%	35.73%	1961	1090
Florence Street - Symmes Road	33750	9.00%	64.27%	35.73%	1952	1085
Symmes Road - Palm Avenue	38350	9.00%	64.27%	35.73%	2218	1233
Palm Avenue - Nundy Avenue	38925	9.00%	64.27%	35.73%	2252	1252
Nundy Avenue - Gibsonton Drive	38800	9.00%	64.27%	35.73%	2244	1248
Gibsonton Drive - Riverview Drive	44300	9.00%	64.27%	35.73%	2562	1425
Riverview Drive - Madison Avenue	39600	9.00%	64.27%	35.73%	2291	1273
Madison Avenue - Port Sutton Road	48250	9.00%	64.27%	35.73%	2791	1552
Port Sutton Road - Hartford Street	50450	9.00%	64.27%	35.73%	2918	1622
Hartford Street - Causeway Boulevard	56650	9.00%	64.27%	35.73%	3277	1822
North of Causeway Boulevard	43050	9.00%	64.27%	35.73%	2490	1384
<b>Kracker Avenue</b>						
East of US 41	515	9.00%	54.17%	45.83%	25	21
West of US 41	365	9.00%	69.23%	30.77%	23	10
<b>Ohio Street</b>						
East of US 41	2200	9.00%	70.43%	29.57%	139	59
<b>Florence Street</b>						
East of US 41	410	9.00%	55.56%	44.44%	21	16
West of US 41	605	9.00%	51.22%	48.78%	28	27
<b>Symmes Road</b>						
East of US 41	13200	9.00%	70.14%	29.86%	833	355
West of US 41	130	9.00%	83.33%	16.67%	10	2
<b>Palm Avenue</b>						
East of US 41	760	9.00%	64.47%	35.53%	44	24
West of US 41	865	9.00%	51.06%	48.94%	40	38
<b>Nundy Avenue</b>						
East of US 41	3100	9.00%	55.42%	44.58%	155	124
West of US 41	530	9.00%	51.43%	48.57%	25	23
<b>Gibsonton Drive/Alice Avenue</b>						
East of US 41	23050	9.00%	66.24%	33.76%	1374	700
West of US 41	1440	9.00%	60.92%	39.08%	79	51
<b>Riverview Drive/Industrial Access Road</b>						
East of US 41	15975	9.00%	59.96%	40.04%	862	576
West of US 41	2025	9.00%	75.25%	24.75%	137	45
<b>Madison Avenue/Pendola Point Road</b>						
East of US 41	14950	9.00%	67.28%	32.72%	905	440
West of US 41	2485	9.00%	83.33%	16.67%	186	37
<b>Port Sutton Road</b>						
West of US 41	2500	9.00%	87.88%	12.12%	198	27
<b>Hartford Street</b>						
East of US 41	2425	9.00%	52.25%	47.75%	114	104
West of US 41	410	9.00%	61.11%	38.89%	23	14
<b>Causeway Boulevard</b>						
East of US 41	48650	9.00%	67.79%	32.21%	2968	1410
West of US 41	51375	9.00%	73.11%	26.89%	3380	1243

**US 41 PD&E - From Kracker Avenue to Causeway Boulevard**  
**YEAR 2040 AM PEAK**  
**Calculation of DDHVs from AADTs**

Traffic Count Location	2040 AADT	K	D-Peak	D-Off Peak	Peak DDHV	Off Peak DDHV
<b>US 41</b>						
South of Kracker Avenue	42400	9.00%	64.27%	35.73%	2453	1363
Kracker Avenue - Ohio Street	42100	9.00%	64.27%	35.73%	2435	1354
Ohio Street - Florence Street	38800	9.00%	64.27%	35.73%	2244	1248
Florence Street - Symmes Road	38975	9.00%	64.27%	35.73%	2254	1253
Symmes Road - Palm Avenue	45000	9.00%	64.27%	35.73%	2603	1447
Palm Avenue - Nundy Avenue	44750	9.00%	64.27%	35.73%	2588	1439
Nundy Avenue - Gibsonton Drive	45200	9.00%	64.27%	35.73%	2615	1453
Gibsonton Drive - Riverview Drive	53650	9.00%	64.27%	35.73%	3103	1725
Riverview Drive - Madison Avenue	47200	9.00%	64.27%	35.73%	2730	1518
Madison Avenue - Port Sutton Road	57625	9.00%	64.27%	35.73%	3333	1853
Port Sutton Road - Hartford Street	60950	9.00%	64.27%	35.73%	3526	1960
Hartford Street - Causeway Boulevard	68550	9.00%	64.27%	35.73%	3965	2204
North of Causeway Boulevard	54450	9.00%	64.27%	35.73%	3150	1751
<b>Kracker Avenue</b>						
East of US 41	620	9.00%	61.11%	38.89%	34	22
West of US 41	435	9.00%	53.33%	46.67%	21	18
<b>Ohio Street</b>						
East of US 41	2640	9.00%	63.64%	36.36%	151	86
<b>Florence Street</b>						
East of US 41	490	9.00%	60.00%	40.00%	26	18
West of US 41	730	9.00%	56.67%	43.33%	37	28
<b>Symmes Road</b>						
East of US 41	17075	9.00%	67.60%	32.40%	1039	498
West of US 41	150	9.00%	91.67%	8.33%	12	1
<b>Palm Avenue</b>						
East of US 41	910	9.00%	60.00%	40.00%	49	33
West of US 41	1040	9.00%	76.00%	24.00%	71	22
<b>Nundy Avenue</b>						
East of US 41	3730	9.00%	56.47%	43.53%	190	146
West of US 41	635	9.00%	61.90%	38.10%	35	22
<b>Gibsonton Drive/Alice Avenue</b>						
East of US 41	29250	9.00%	52.02%	47.98%	1369	1263
West of US 41	1640	9.00%	54.12%	45.88%	80	68
<b>Riverview Drive/Industrial Access Road</b>						
East of US 41	21750	9.00%	53.94%	46.06%	1056	902
West of US 41	2310	9.00%	75.65%	24.35%	157	51
<b>Madison Avenue/Pendola Point Road</b>						
East of US 41	18375	9.00%	65.65%	34.35%	1086	568
West of US 41	2830	9.00%	60.00%	40.00%	153	102
<b>Port Sutton Road</b>						
West of US 41	3000	9.00%	71.74%	28.26%	194	76
<b>Hartford Street</b>						
East of US 41	2910	9.00%	55.47%	44.53%	145	117
West of US 41	490	9.00%	80.77%	19.23%	36	8
<b>Causeway Boulevard</b>						
East of US 41	64625	9.00%	72.06%	27.94%	4191	1625
West of US 41	62200	9.00%	77.98%	22.02%	4365	1233

**US 41 PD&E - From Kracker Avenue to Causeway Boulevard**

**YEAR 2040 PM PEAK**

**Calculation of DDHVs from AADTs**

Traffic Count Location	2040 AADT	K	D-Peak	D-Off Peak	Peak DDHV	Off Peak DDHV
<b>US 41</b>						
South of Kracker Avenue	42400	9.00%	64.27%	35.73%	2453	1363
Kracker Avenue - Ohio Street	42100	9.00%	64.27%	35.73%	2435	1354
Ohio Street - Florence Street	38800	9.00%	64.27%	35.73%	2244	1248
Florence Street - Symmes Road	38975	9.00%	64.27%	35.73%	2254	1253
Symmes Road - Palm Avenue	45000	9.00%	64.27%	35.73%	2603	1447
Palm Avenue - Nundy Avenue	44750	9.00%	64.27%	35.73%	2588	1439
Nundy Avenue - Gibsonton Drive	45200	9.00%	64.27%	35.73%	2615	1453
Gibsonton Drive - Riverview Drive	53650	9.00%	64.27%	35.73%	3103	1725
Riverview Drive - Madison Avenue	47200	9.00%	64.27%	35.73%	2730	1518
Madison Avenue - Port Sutton Road	57625	9.00%	64.27%	35.73%	3333	1853
Port Sutton Road - Hartford Street	60950	9.00%	64.27%	35.73%	3526	1960
Hartford Street - Causeway Boulevard	68550	9.00%	64.27%	35.73%	3965	2204
North of Causeway Boulevard	54450	9.00%	64.27%	35.73%	3150	1751
<b>Kracker Avenue</b>						
East of US 41	620	9.00%	54.17%	45.83%	30	26
West of US 41	435	9.00%	69.23%	30.77%	27	12
<b>Ohio Street</b>						
East of US 41	2640	9.00%	70.43%	29.57%	167	70
<b>Florence Street</b>						
East of US 41	490	9.00%	55.56%	44.44%	25	20
West of US 41	730	9.00%	51.22%	48.78%	34	32
<b>Symmes Road</b>						
East of US 41	17075	9.00%	70.14%	29.86%	1078	459
West of US 41	150	9.00%	83.33%	16.67%	11	2
<b>Palm Avenue</b>						
East of US 41	910	9.00%	64.47%	35.53%	53	29
West of US 41	1040	9.00%	51.06%	48.94%	48	46
<b>Nundy Avenue</b>						
East of US 41	3730	9.00%	55.42%	44.58%	186	150
West of US 41	635	9.00%	51.43%	48.57%	29	28
<b>Gibsonton Drive/Alice Avenue</b>						
East of US 41	29250	9.00%	66.24%	33.76%	1744	889
West of US 41	1640	9.00%	60.92%	39.08%	90	58
<b>Riverview Drive/Industrial Access Road</b>						
East of US 41	21750	9.00%	59.96%	40.04%	1174	784
West of US 41	2310	9.00%	75.25%	24.75%	156	51
<b>Madison Avenue/Pendola Point Road</b>						
East of US 41	18375	9.00%	67.28%	32.72%	1113	541
West of US 41	2830	9.00%	83.33%	16.67%	212	42
<b>Port Sutton Road</b>						
West of US 41	3000	9.00%	87.88%	12.12%	237	33
<b>Hartford Street</b>						
East of US 41	2910	9.00%	52.25%	47.75%	137	125
West of US 41	490	9.00%	61.11%	38.89%	27	17
<b>Causeway Boulevard</b>						
East of US 41	64625	9.00%	67.79%	32.21%	3943	1873
West of US 41	62200	9.00%	73.11%	26.89%	4093	1505

US 41 - From Kracker Avenue to South of Causeway Boulevard  
 Estimation of 2020 AM Peak Hour Traffic Volumes  
 NB Peak Direction

2020 AM Peak:

Intersection	Movement	AM Turning Volume (Raw TMC)	Approach Total	Turn Percent (%)	2020 AM DDHV	2020 Turning Volume
US 41 @ Kracker Avenue	EBLT	3	8	38%	14	5
	EBTH	0		0%		0
	EBRT	5		63%		9
	NBLT	5	1371	0%	1596	6
	NBTH	1360		99%		1583
	NBRT	6		0%		7
	WBLT	8		73%		17
	WBTH	0	11	0%	23	0
	WBRT	3		27%		6
	SBLT	1		0%		1
SBTH	649	652	100%	908	904	
SBRT	2		0%		3	
US 41 @ Ohio Street	NBTH	1367	1380	99%	1634	1619
	NBRT	13		1%		15
	WBLT	16	32	50%	58	29
	WBRT	16		50%		29
	SBLT	43		6%		59
SBTH	637	680	94%	933	874	
US 41 @ Florence Street	EBLT	8	13	62%	19	12
	EBTH	0		0%		0
	EBRT	5		38%		7
	NBLT	5	1460	0%	1677	6
	NBTH	1455		100%		1671
	NBRT	0		0%		0
	WBLT	1		33%		6
	WBTH	0	3	0%	18	0
	WBRT	2		67%		12
	SBLT	2		0%		3
SBTH	627	640	98%	916	897	
SBRT	11		2%		16	
US 41 @ Symmes Road	EBLT	1	1	100%	1	1
	EBTH	0		0%		0
	EBRT	0		0%		0
	NBLT	11	1417	1%	1649	13
	NBTH	1269		90%		1477
	NBRT	137		10%		159
	WBLT	138		30%		170
	WBTH	0	461	0%	569	0
	WBRT	323		70%		399
	SBLT	85		15%		149
SBTH	497	582	85%	1019	870	
SBRT	0		0%		0	
US 41 @ Palm Avenue	EBLT	13	19	68%	47	32
	EBTH	0		0%		0
	EBRT	6		32%		15
	NBLT	3	1687	0%	1834	3
	NBTH	1678		99%		1824
	NBRT	6		0%		7
	WBLT	2		13%		3
	WBTH	0	16	0%	22	0
	WBRT	14		88%		19
	SBLT	18		3%		30
SBTH	612	633	97%	1064	1029	
SBRT	3		0%		5	

US 41 - From Kracker Avenue to South of Causeway Boulevard  
 Estimation of 2020 AM Peak Hour Traffic Volumes  
 NB Peak Direction

US 41 @ Nundy Avenue	EBLT	1	8	13%	15	2
	EBTH	2		25%		4
	EBRT	5		63%		9
	NBLT	11	1732	1%		12
	NBTH	1703		98%		1883
	NBRT	18	1%	20		
	WBLT	19	48	40%		50
	WBTH	0		0%		0
	WBRT	29		60%		77
	SBLT	17	604	3%		29
	SBTH	585		97%		1007
SBRT	2	0%		3		
US 41 @ Gibsonton Drive/Alice Avenue	EBLT	12	39	31%	51	16
	EBTH	22		56%		29
	EBRT	5		13%		7
	NBLT	11	1728	1%		12
	NBTH	1507		87%		1632
	NBRT	210	12%	227		
	WBLT	136	373	36%		288
	WBTH	27		7%		57
	WBRT	210		56%		444
	SBLT	112	539	21%		233
	SBTH	419		78%		872
SBRT	8	1%		17		
US 41 @ Riverview Drive/Industrial Access Road	EBLT	6	28	21%	38	8
	EBTH	9		32%		12
	EBRT	13		46%		18
	NBLT	59	1874	3%		64
	NBTH	1639		87%		1766
	NBRT	176	9%	190		
	WBLT	126	226	56%		276
	WBTH	14		6%		31
	WBRT	86		38%		188
	SBLT	8	431	2%		19
	SBTH	409		95%		976
SBRT	14	3%		33		
US 41 @ Madison Avenue/Pendola Point Road	EBLT	23	36	64%	77	49
	EBTH	4		11%		9
	EBRT	9		25%		19
	NBLT	14	1928	1%		13
	NBTH	1856		96%		1782
	NBRT	58	3%	56		
	WBLT	50	409	12%		83
	WBTH	12		3%		20
	WBRT	347		85%		576
	SBLT	152	581	26%		327
	SBTH	401		69%		863
SBRT	28	5%		60		
					1040	
					1871	
					789	
					1122	
					2019	
					495	
					1029	
					77	
					1851	
					679	
					1251	



US 41 - From Kracker Avenue to South of Causeway Boulevard  
 Estimation of 2020 AM Peak Hour Traffic Volumes  
 NB Peak Direction

US 41 @ Port Sutton Road	EBLT	19	26	73%	
	EBRT	7		27%	
	NBLT	25		1%	
	NBTH	2181		99%	
	SBTH	582		93%	
	SBRT	41	623	7%	
US 41 @ Hartford Street	EBLT	3	2205	60%	
	EBRT	2		5	40%
	NBLT	9		0%	
	NBTH	2179		99%	
	NBRT	17		1%	
	WBLT	8		17%	
	WBRT	40		48	83%
	SBLT	37		5%	
	SBTH	675		93%	
	SBRT	12	724	2%	
US 41 @ Causeway Boulevard	EBLT	46	2319	7%	
	EBTH	295		664	44%
	EBRT	323		49%	
	NBLT	1401		60%	
	NBTH	867		37%	
	NBRT	51		2%	
	WBLT	51		4%	
	WBTH	901		78%	
	WBRT	198		1150	17%
	SBLT	100		22%	
	SBTH	314		68%	
	SBRT	50	464	11%	

	37
51	14
	25
2250	2225
	1200
1285	85
	4
6	2
	9
	2284
2311	18
	16
97	81
	74
	1342
1439	24
	56
	357
804	391
	1564
	968
2588	57
	94
	1659
2117	364
	220
	690
1019	110

US 41 - From Kracker Avenue to South of Causeway Boulevard  
 Estimation of 2020 PM Peak Hour Traffic Volumes  
 SB Peak Direction

2020 PM Peak:

Intersection	Movement	PM Turning Volume (Raw TMC)	Approach Total	Turn Percent (%)	2020 PM	2020 Turning
					DDHV	Volume
US 41 @ Kracker Avenue	EBLT	2	4	50%	8	4
	EBTH	0		0%		0
	EBRT	2		50%		4
	NBLT	5	686	1%	888	6
	NBTH	674		98%		872
	NBRT	7		1%		9
	WBLT	6	13	46%	20	9
	WBTH	1		8%		2
	WBRT	6		46%		9
	SBLT	4	1394	0%	1634	5
	SBTH	1387		99%		1626
SBRT	3	0%		4		
US 41 @ Ohio Street	NBTH	664	674	99%	908	895
	NBRT	10		1%		13
	WBLT	12	34	35%	47	17
	WBRT	22		65%		30
	SBLT	71		5%		84
SBTH	1345	1416	95%	1677	1593	
US 41 @ Florence Street	EBLT	15	21	71%	22	16
	EBTH	0		0%		0
	EBRT	6		29%		6
	NBLT	8	743	1%	933	10
	NBTH	734		99%		922
	NBRT	1		0%		1
	WBLT	1	4	25%	13	3
	WBTH	0		0%		0
	WBRT	3		75%		10
	SBLT	4	1349	0%	1649	5
	SBTH	1349		99%		1630
SBRT	12	1%		14		
US 41 @ Symmes Road	EBLT	0	1	0%	2	0
	EBTH	1		100%		2
	EBRT	0		0%		0
	NBLT	2	764	0%	916	2
	NBTH	680		89%		815
	NBRT	82		11%		98
	WBLT	79	169	47%	251	117
	WBTH	0		0%		0
	WBRT	90		53%		134
	SBLT	314	1211	21%	1834	377
SBTH	1211	79%		1454		
SBRT	3	0%		4		
US 41 @ Palm Avenue	EBLT	19	24	79%	32	25
	EBTH	2		8%		3
	EBRT	3		13%		4
	NBLT	4	878	0%	1019	5
	NBTH	865		99%		1004
	NBRT	9		1%		10
	WBLT	40	98	41%	35	14
	WBTH	2		2%		1
	WBRT	56		57%		20
	SBLT	43	1633	3%	1915	49
	SBTH	1633		96%		1847
SBRT	17	1%		19		

US 41 - From Kracker Avenue to South of Causeway Boulevard  
 Estimation of 2020 PM Peak Hour Traffic Volumes  
 SB Peak Direction

US 41 @ Nundy Avenue	EBLT	4	17	24%	1064	4
	EBTH	0		0%		0
	EBRT	13		76%		15
	NBLT	9	826	1%		12
	NBTH	772		93%		994
	NBRT	45	5%	58		
	WBLT	47	74	64%		64
	WBTH	2		3%		3
	WBRT	25		34%		34
	SBLT	47	1716	3%		51
	SBTH	1662		97%		1812
SBRT	7	0%		8		
US 41 @ Gibsonton Drive/Alice Avenue	EBLT	7	34	21%	1040	9
	EBTH	16		47%		21
	EBRT	11		32%		14
	NBLT	9	839	1%		11
	NBTH	575		69%		713
	NBRT	255	30%	316		
	WBLT	223	346	64%		330
	WBTH	30		9%		44
	WBRT	93		27%		138
	SBLT	408	1754	23%		470
	SBTH	1332		76%		1533
SBRT	14	1%		16		
US 41 @ Riverview Drive/Industrial Access Road	EBLT	16	76	21%	1122	25
	EBTH	27		36%		42
	EBRT	33		43%		52
	NBLT	10	697	1%		16
	NBTH	490		70%		789
	NBRT	197	28%	317		
	WBLT	196	219	89%		329
	WBTH	4		2%		7
	WBRT	19		9%		32
	SBLT	104	1735	6%		111
	SBTH	1620		93%		1728
SBRT	11	1%		12		
US 41 @ Madison Avenue/Pendola Point Road	EBLT	19	30	63%	1029	101
	EBTH	9		30%		48
	EBRT	2		7%		11
	NBLT	1	569	0%		2
	NBTH	540		95%		977
	NBRT	28	5%	51		
	WBLT	76	215	35%		120
	WBTH	0		0%		0
	WBRT	139		65%		219
	SBLT	405	2087	19%		437
	SBTH	1677		80%		1808
SBRT	5	0%		5		

US 41 - From Kracker Avenue to South of Causeway Boulevard  
 Estimation of 2020 PM Peak Hour Traffic Volumes  
 SB Peak Direction

US 41 @ Port Sutton Road	EBLT	17	29	59%	158	93	
	EBRT	12		41%		65	
	NBLT	0		0%		0	
	NBTH	728	728	100%		1251	1251
	SBTH	2130	2134	100%		2307	
	SBRT	4		0%		4	
US 41 @ Hartford Street	EBLT	7	11	64%	2311	11	
	EBRT	4		36%		7	
	NBLT	5		1%		8	
	NBTH	774	794	97%		1253	
	NBRT	15	2%	24			
	WBLT	15	58	26%		24	
	WBRT	43		74%		67	
	SBLT	38	2%	46			
	SBTH	2120	2160	98%		2540	
	SBRT	2		0%		2	
US 41 @ Causeway Boulevard	EBLT	61	2099	3%	2588	78	
	EBTH	821		39%		1044	
	EBRT	1217		58%		1548	
	NBLT	410	909	45%		649	
	NBTH	396		44%		627	
	NBRT	103		11%		163	
	WBLT	55	545	10%		95	
	WBTH	343		63%		595	
	WBRT	147	27%	255			
	SBLT	223	1039	21%		393	
	SBTH	797		77%		1405	
	SBRT	19		2%		34	

US 41 - From Kracker Avenue to South of Causeway Boulevard  
 Estimation of 2030 AM Peak Hour Traffic Volumes  
 NB Peak Direction

2030 AM Peak:

Intersection	Movement	AM Turning Volume (Raw TMC)	Approach Total	Turn Percent (%)	2030 AM DDHV	2030 Turning Volume
US 41 @ Kracker Avenue	EBLT	3	8	38%	18	7
	EBTH	0		0%		0
	EBRT	5		63%		11
	NBLT	5	1371	0%	2025	7
	NBTH	1360		99%		2009
	NBRT	6		0%		9
	WBLT	8		73%		20
	WBTH	0	11	0%	28	0
	WBRT	3		27%		8
	SBLT	1		0%		2
SBTH	649	652	100%	1130	1125	
SBRT	2		0%		3	
US 41 @ Ohio Street	NBTH	1367	1380	99%	2033	2014
	NBRT	13		1%		19
	WBLT	16	32	50%	72	36
	WBRT	16		50%		36
	SBLT	43		6%		69
SBTH	637	680	94%	1090	1021	
US 41 @ Florence Street	EBLT	8	13	62%	24	15
	EBTH	0		0%		0
	EBRT	5		38%		9
	NBLT	5	1460	0%	1961	7
	NBTH	1455		100%		1954
	NBRT	0		0%		0
	WBLT	1		33%		7
	WBTH	0	3	0%	22	0
	WBRT	2		67%		15
	SBLT	2		0%		3
SBTH	627	640	98%	1085	1063	
SBRT	11		2%		19	
US 41 @ Symmes Road	EBLT	1	1	100%	1	1
	EBTH	0		0%		0
	EBRT	0		0%		0
	NBLT	11	1417	1%	1952	15
	NBTH	1269		90%		1748
	NBRT	137		10%		189
	WBLT	138		30%		240
	WBTH	0	461	0%	803	0
	WBRT	323		70%		563
	SBLT	85		15%		180
SBTH	497	582	85%	1233	1053	
SBRT	0		0%		0	
US 41 @ Palm Avenue	EBLT	13	19	68%	59	40
	EBTH	0		0%		0
	EBRT	6		32%		19
	NBLT	3	1687	0%	2218	4
	NBTH	1678		99%		2206
	NBRT	6		0%		8
	WBLT	2		13%		3
	WBTH	0	16	0%	27	0
	WBRT	14		88%		24
	SBLT	18		3%		36
SBTH	612	633	97%	1252	1210	
SBRT	3		0%		6	

US 41 - From Kracker Avenue to South of Causeway Boulevard  
 Estimation of 2030 AM Peak Hour Traffic Volumes  
 NB Peak Direction

US 41 @ Nundy Avenue	EBLT	1	8	13%	18	2
	EBTH	2		25%		5
	EBRT	5		63%		11
	NBLT	11	1732	1%		14
	NBTH	1703		98%		2214
	NBRT	18	1%	23		
	WBLT	19	48	40%		63
	WBTH	0		0%		0
	WBRT	29		60%		95
	SBLT	17	604	3%		35
	SBTH	585		97%		1209
SBRT	2	0%		4		
US 41 @ Gibsonton Drive/Alice Avenue	EBLT	12	39	31%	59	18
	EBTH	22		56%		33
	EBRT	5		13%		8
	NBLT	11	1728	1%		14
	NBTH	1507		87%		1957
	NBRT	210	12%	273		
	WBLT	136	373	36%		393
	WBTH	27		7%		78
	WBRT	210		56%		607
	SBLT	112	539	21%		296
	SBTH	419		78%		1108
SBRT	8	1%		21		
US 41 @ Riverview Drive/Industrial Access Road	EBLT	6	28	21%	44	9
	EBTH	9		32%		14
	EBRT	13		46%		20
	NBLT	59	1874	3%		81
	NBTH	1639		87%		2241
	NBRT	176	9%	241		
	WBLT	126	226	56%		433
	WBTH	14		6%		48
	WBRT	86		38%		295
	SBLT	8	431	2%		24
	SBTH	409		95%		1208
SBRT	14	3%		41		
US 41 @ Madison Avenue/Pendola Point Road	EBLT	23	36	64%	89	57
	EBTH	4		11%		10
	EBRT	9		25%		22
	NBLT	14	1928	1%		17
	NBTH	1856		96%		2205
	NBRT	58	3%	69		
	WBLT	50	409	12%		108
	WBTH	12		3%		26
	WBRT	347		85%		749
	SBLT	152	581	26%		406
	SBTH	401		69%		1071
SBRT	28	5%		75		
					1552	

US 41 - From Kracker Avenue to South of Causeway Boulevard  
 Estimation of 2030 AM Peak Hour Traffic Volumes  
 NB Peak Direction

US 41 @ Port Sutton Road	EBLT	19	26	73%
	EBRT	7		27%
	NBLT	25	2206	1%
	NBTH	2181		99%
	SBTH	582		93%
SBRT	41	623	7%	
US 41 @ Hartford Street	EBLT	3	5	60%
	EBRT	2		40%
	NBLT	9	2205	0%
	NBTH	2179		99%
	NBRT	17		1%
	WBLT	8	48	17%
	WBRT	40		83%
	SBLT	37	724	5%
	SBTH	675		93%
SBRT	12	2%		
US 41 @ Causeway Boulevard	EBLT	46	664	7%
	EBTH	295		44%
	EBRT	323	2319	49%
	NBLT	1401		60%
	NBTH	867		37%
	NBRT	51	1150	2%
	WBLT	51		4%
	WBTH	901	464	78%
	WBRT	198		17%
	SBLT	100		22%
	SBTH	314	464	68%
SBRT	50	11%		

64	47
	17
2791	32
	2759
1622	1515
	107
7	4
	3
2918	12
	2884
121	22
	20
1822	101
	93
1822	1699
	30
1018	71
	452
3277	495
	1980
3155	1225
	72
1384	140
	2472
1384	543
	298
1384	937
	149

US 41 - From Kracker Avenue to South of Causeway Boulevard  
 Estimation of 2030 PM Peak Hour Traffic Volumes  
 SB Peak Direction

2030 PM Peak:

Intersection	Movement	PM Turning Volume (Raw TMC)	Approach Total	Turn Percent (%)	2030 PM DDHV	2030 Turning Volume
US 41 @ Kracker Avenue	EBLT	2	4	50%	10	5
	EBTH	0		0%		0
	EBRT	2		50%		5
	NBLT	5	686	1%	1125	8
	NBTH	674		98%		1105
	NBRT	7		1%		11
	WBLT	6	13	46%	25	12
	WBTH	1		8%		2
	WBRT	6		46%		12
	SBLT	4	1394	0%	2033	6
	SBTH	1387		99%		2023
SBRT	3	0%		4		
US 41 @ Ohio Street	NBTH	664	674	99%	1130	1113
	NBRT	10		1%		17
	WBLT	12	34	35%	59	21
	WBRT	22		65%		38
	SBLT	71		5%		98
SBTH	1345	1416	95%	1961	1863	
US 41 @ Florence Street	EBLT	15	21	71%	28	20
	EBTH	0		0%		0
	EBRT	6		29%		8
	NBLT	8	743	1%	1090	12
	NBTH	734		99%		1077
	NBRT	1		0%		1
	WBLT	1	4	25%	16	4
	WBTH	0		0%		0
	WBRT	3		75%		12
	SBLT	4	1349	0%	1952	6
	SBTH	1349		99%		1929
SBRT	12	1%		17		
US 41 @ Symmes Road	EBLT	0	1	0%	2	0
	EBTH	1		100%		2
	EBRT	0		0%		0
	NBLT	2	764	0%	1085	3
	NBTH	680		89%		966
	NBRT	82		11%		116
	WBLT	79	169	47%	355	166
	WBTH	0		0%		0
	WBRT	90		53%		189
	SBLT	314	1211	21%	2218	456
	SBTH	1211		79%		1758
SBRT	3	0%		4		
US 41 @ Palm Avenue	EBLT	19	24	79%	40	32
	EBTH	2		8%		3
	EBRT	3		13%		5
	NBLT	4	878	0%	1233	6
	NBTH	865		99%		1215
	NBRT	9		1%		13
	WBLT	40	98	41%	44	18
	WBTH	2		2%		1
	WBRT	56		57%		25
	SBLT	43	1633	3%	2252	57
	SBTH	1633		96%		2172
SBRT	17	1%		23		



US 41 - From Kracker Avenue to South of Causeway Boulevard  
 Estimation of 2030 PM Peak Hour Traffic Volumes  
 SB Peak Direction

US 41 @ Nundy Avenue	EBLT	4	17	24%	23	5
	EBTH	0		0%		0
	EBRT	13		76%		18
	NBLT	9	826	1%	1252	14
	NBTH	772		93%		1170
	NBRT	45		5%		68
	WBLT	47	74	64%	124	79
	WBTH	2		3%		3
	WBRT	25		34%		42
	SBLT	47	1716	3%	2244	61
	SBTH	1662		97%		2173
SBRT	7	0%		9		
US 41 @ Gibsonton Drive/Alice Avenue	EBLT	7	34	21%	51	11
	EBTH	16		47%		24
	EBRT	11		32%		17
	NBLT	9	839	1%	1248	13
	NBTH	575		69%		855
	NBRT	255		30%		379
	WBLT	223	346	64%	700	451
	WBTH	30		9%		61
	WBRT	93		27%		188
	SBLT	408	1754	23%	2562	596
	SBTH	1332		76%		1946
SBRT	14	1%		20		
US 41 @ Riverview Drive/Industrial Access Road	EBLT	16	76	21%	137	29
	EBTH	27		36%		49
	EBRT	33		43%		59
	NBLT	10	697	1%	1425	20
	NBTH	490		70%		1002
	NBRT	197		28%		403
	WBLT	196	219	89%	576	516
	WBTH	4		2%		11
	WBRT	19		9%		50
	SBLT	104	1735	6%	2291	137
	SBTH	1620		93%		2139
SBRT	11	1%		15		
US 41 @ Madison Avenue/Pendola Point Road	EBLT	19	30	63%	186	118
	EBTH	9		30%		56
	EBRT	2		7%		12
	NBLT	1	569	0%	1273	2
	NBTH	540		95%		1208
	NBRT	28		5%		63
	WBLT	76	215	35%	440	156
	WBTH	0		0%		0
	WBRT	139		65%		284
	SBLT	405	2087	19%	2791	542
	SBTH	1677		80%		2243
SBRT	5	0%		7		

US 41 - From Kracker Avenue to South of Causeway Boulevard  
 Estimation of 2030 PM Peak Hour Traffic Volumes  
 SB Peak Direction

US 41 @ Port Sutton Road	EBLT	17	29	59%	198	116
	EBRT	12		41%		82
	NBLT	0		0%		0
	NBTH	728	728	100%		1552
	SBTH	2130	2134	100%		2913
	SBRT	4		0%		5
US 41 @ Hartford Street	EBLT	7	11	64%	23	15
	EBRT	4		36%		8
	NBLT	5		1%		10
	NBTH	774	794	97%	1622	1581
	NBRT	15		2%		31
	WBLT	15	58	26%	114	29
	WBRT	43		74%		85
	SBLT	38		2%		58
	SBTH	2120	2160	98%	3277	3216
SBRT	2	0%		3		
US 41 @ Causeway Boulevard	EBLT	61	2099	3%	3380	98
	EBTH	821		39%		1322
	EBRT	1217		58%		1960
	NBLT	410	909	45%	1822	822
	NBTH	396		44%		794
	NBRT	103	545	11%	1410	206
	WBLT	55		10%		142
	WBTH	343		63%		887
	WBRT	147	1039	27%	2490	380
	SBLT	223		21%		534
	SBTH	797	77%	1910		
	SBRT	19	2%	46		

US 41 - From Kracker Avenue to South of Causeway Boulevard  
 Estimation of 2040 AM Peak Hour Traffic Volumes  
 NB Peak Direction

2040 AM Peak:

Intersection	Movement	AM Turning Volume (Raw TMC)	Approach Total	Turn Percent (%)	2040 AM DDHV	2040 Turning Volume
US 41 @ Kracker Avenue	EBLT	3	8	38%	21	8
	EBTH	0		0%		0
	EBRT	5		63%		13
	NBLT	5	1371	0%	2453	9
	NBTH	1360		99%		2433
	NBRT	6		0%		11
	WBLT	8		73%		25
	WBTH	0	11	0%	34	0
	WBRT	3		27%		9
	SBLT	1		0%		2
SBTH	649	652	100%	1354	1348	
SBRT	2		0%		4	
US 41 @ Ohio Street	NBTH	1367	1380	99%	2435	2412
	NBRT	13		1%		23
	WBLT	16	32	50%	86	43
	WBRT	16		50%		43
	SBLT	43		6%		79
SBTH	637	680	94%	1248	1169	
US 41 @ Florence Street	EBLT	8	13	62%	28	17
	EBTH	0		0%		0
	EBRT	5		38%		11
	NBLT	5	1460	0%	2244	8
	NBTH	1455		100%		2236
	NBRT	0		0%		0
	WBLT	1		33%		9
	WBTH	0	3	0%	26	0
	WBRT	2		67%		17
	SBLT	2		0%		4
SBTH	627	640	98%	1253	1228	
SBRT	11		2%		22	
US 41 @ Symmes Road	EBLT	1	1	100%	1	1
	EBTH	0		0%		0
	EBRT	0		0%		0
	NBLT	11	1417	1%	2254	17
	NBTH	1269		90%		2019
	NBRT	137		10%		218
	WBLT	138		30%		311
	WBTH	0	461	0%	1039	0
	WBRT	323		70%		728
	SBLT	85		15%		211
SBTH	497	582	85%	1447	1236	
SBRT	0		0%		0	
US 41 @ Palm Avenue	EBLT	13	19	68%	71	49
	EBTH	0		0%		0
	EBRT	6		32%		22
	NBLT	3	1687	0%	2603	5
	NBTH	1678		99%		2589
	NBRT	6		0%		9
	WBLT	2		13%		4
	WBTH	0	16	0%	33	0
	WBRT	14		88%		29
	SBLT	18		3%		41
SBTH	612	633	97%	1439	1391	
SBRT	3		0%		7	

US 41 - From Kracker Avenue to South of Causeway Boulevard  
 Estimation of 2040 AM Peak Hour Traffic Volumes  
 NB Peak Direction

US 41 @ Nundy Avenue	EBLT	1	8	13%	22	3	
	EBTH	2		25%		6	
	EBRT	5		63%		14	
	NBLT	11	1732	1%		16	
	NBTH	1703		98%		2545	
	NBRT	18	48	1%		27	
	WBLT	19		40%		75	
	WBTH	0		0%		0	
	WBRT	29	604	60%		190	115
	SBLT	17		3%		41	
	SBTH	585	604	97%		1407	
SBRT	2	0%		1453	5		
US 41 @ Gibsonton Drive/Alice Avenue	EBLT	12	39	31%	68	21	
	EBTH	22		56%		38	
	EBRT	5		13%		9	
	NBLT	11	1728	1%		17	
	NBTH	1507		87%		2281	
	NBRT	210	373	12%		2615	318
	WBLT	136		36%		499	
	WBTH	27		7%		99	
	WBRT	210	539	56%		1369	771
	SBLT	112		21%		358	
	SBTH	419	539	78%		1725	1341
SBRT	8	1%		26			
US 41 @ Riverview Drive/Industrial Access Road	EBLT	6	28	21%	51	11	
	EBTH	9		32%		16	
	EBRT	13		46%		24	
	NBLT	59	1874	3%		98	
	NBTH	1639		87%		2714	
	NBRT	176	226	9%		3103	291
	WBLT	126		56%		589	
	WBTH	14		6%		65	
	WBRT	86	431	38%		1056	402
	SBLT	8		2%		28	
	SBTH	409	431	95%		1518	1441
SBRT	14	3%		49			
US 41 @ Madison Avenue/Pendola Point Road	EBLT	23	36	64%	102	65	
	EBTH	4		11%		11	
	EBRT	9		25%		26	
	NBLT	14	1928	1%		20	
	NBTH	1856		96%		2628	
	NBRT	58	409	3%		2730	82
	WBLT	50		12%		133	
	WBTH	12		3%		32	
	WBRT	347	581	85%		1086	921
	SBLT	152		26%		485	
	SBTH	401	581	69%		1279	
SBRT	28	5%		1853	89		

US 41 - From Kracker Avenue to South of Causeway Boulevard  
 Estimation of 2040 AM Peak Hour Traffic Volumes  
 NB Peak Direction

US 41 @ Port Sutton Road	EBLT	19	26	73%
	EBRT	7		27%
	NBLT	25	2206	1%
	NBTH	2181		99%
	SBTH	582		93%
SBRT	41	623	7%	
US 41 @ Hartford Street	EBLT	3	5	60%
	EBRT	2		40%
	NBLT	9	2205	0%
	NBTH	2179		99%
	NBRT	17		1%
	WBLT	8	48	17%
	WBRT	40		83%
	SBLT	37	724	5%
	SBTH	675		93%
SBRT	12	2%		
US 41 @ Causeway Boulevard	EBLT	46	664	7%
	EBTH	295		44%
	EBRT	323	2319	49%
	NBLT	1401		60%
	NBTH	867		37%
	NBRT	51	1150	2%
	WBLT	51		4%
	WBTH	901	464	78%
	WBRT	198		17%
	SBLT	100		22%
	SBTH	314	464	68%
SBRT	50	11%		

76	56
	20
3333	38
	3295
1960	1831
	129
8	5
	3
3526	14
	3484
145	27
	24
2204	121
	113
2204	2055
	37
1233	85
	548
3965	600
	2395
4191	1482
	87
1751	186
	3284
1751	722
	377
1751	1185
	189

US 41 - From Kracker Avenue to South of Causeway Boulevard  
 Estimation of 2040 PM Peak Hour Traffic Volumes  
 SB Peak Direction

2040 PM Peak:

Intersection	Movement	PM Turning Volume (Raw TMC)	Approach Total	Turn Percent (%)	2040 PM	2040 Turning
					DDHV	Volume
US 41 @ Kracker Avenue	EBLT	2	4	50%	12	6
	EBTH	0		0%		0
	EBRT	2		50%		6
	NBLT	5	686	1%	1363	10
	NBTH	674		98%		1339
	NBRT	7		1%		14
	WBLT	6	13	46%	30	14
	WBTH	1		8%		2
	WBRT	6		46%		14
	SBLT	4	1394	0%	2435	7
	SBTH	1387		99%		2423
	SBRT	3		0%		5
US 41 @ Ohio Street	NBTH	664	674	99%	1354	1334
	NBRT	10		1%		20
	WBLT	12	34	35%	70	25
	WBRT	22		65%		45
	SBLT	71	1416	5%	2244	113
	SBTH	1345		95%		2131
US 41 @ Florence Street	EBLT	15	21	71%	34	24
	EBTH	0		0%		0
	EBRT	6		29%		10
	NBLT	8	743	1%	1248	13
	NBTH	734		99%		1233
	NBRT	1		0%		2
	WBLT	1	4	25%	20	5
	WBTH	0		0%		0
	WBRT	3		75%		15
	SBLT	4	1365	0%	2254	7
	SBTH	1349		99%		2228
	SBRT	12		1%		20
US 41 @ Symmes Road	EBLT	0	1	0%	2	0
	EBTH	1		100%		2
	EBRT	0		0%		0
	NBLT	2	764	0%	1253	3
	NBTH	680		89%		1115
	NBRT	82		11%		134
	WBLT	79	169	47%	459	215
	WBTH	0		0%		0
	WBRT	90		53%		244
	SBLT	314	1528	21%	2603	535
	SBTH	1211		79%		2063
	SBRT	3		0%		5
US 41 @ Palm Avenue	EBLT	19	24	79%	48	38
	EBTH	2		8%		4
	EBRT	3		13%		6
	NBLT	4	878	0%	1447	7
	NBTH	865		99%		1426
	NBRT	9		1%		15
	WBLT	40	98	41%	53	22
	WBTH	2		2%		1
	WBRT	56		57%		30
	SBLT	43	1693	3%	2588	66
	SBTH	1633		96%		2496
	SBRT	17		1%		26

US 41 - From Kracker Avenue to South of Causeway Boulevard  
 Estimation of 2040 PM Peak Hour Traffic Volumes  
 SB Peak Direction

US 41 @ Nundy Avenue	EBLT	4	17	24%	1439	7
	EBTH	0		0%		0
	EBRT	13		76%		21
	NBLT	9	826	1%		16
	NBTH	772		93%		1345
	NBRT	45	5%	78		
	WBLT	47	74	64%		95
	WBTH	2		3%		4
	WBRT	25		34%		51
	SBLT	47	1716	3%		72
	SBTH	1662		97%		2533
SBRT	7	0%		11		
US 41 @ Gibsonton Drive/Alice Avenue	EBLT	7	34	21%	1453	12
	EBTH	16		47%		27
	EBRT	11		32%		19
	NBLT	9	839	1%		16
	NBTH	575		69%		996
	NBRT	255	30%	442		
	WBLT	223	346	64%		573
	WBTH	30		9%		77
	WBRT	93		27%		239
	SBLT	408	1754	23%		722
	SBTH	1332		76%		2356
SBRT	14	1%		25		
US 41 @ Riverview Drive/Industrial Access Road	EBLT	16	76	21%	1725	33
	EBTH	27		36%		55
	EBRT	33		43%		68
	NBLT	10	697	1%		25
	NBTH	490		70%		1213
	NBRT	197	28%	488		
	WBLT	196	219	89%		702
	WBTH	4		2%		14
	WBRT	19		9%		68
	SBLT	104	1735	6%		164
	SBTH	1620		93%		2549
SBRT	11	1%		17		
US 41 @ Madison Avenue/Pendola Point Road	EBLT	19	30	63%	1518	134
	EBTH	9		30%		64
	EBRT	2		7%		14
	NBLT	1	569	0%		3
	NBTH	540		95%		1441
	NBRT	28	5%	75		
	WBLT	76	215	35%		191
	WBTH	0		0%		0
	WBRT	139		65%		350
	SBLT	405	2087	19%		647
	SBTH	1677		80%		2678
SBRT	5	0%		8		
					3333	

US 41 - From Kracker Avenue to South of Causeway Boulevard  
 Estimation of 2040 PM Peak Hour Traffic Volumes  
 SB Peak Direction

US 41 @ Port Sutton Road	EBLT	17	29	59%	237	139	
	EBRT	12		41%		98	
	NBLT	0		0%		0	
	NBTH	728	728	100%		1853	
	SBTH	2130	2134	100%		3519	
	SBRT	4		0%		7	
US 41 @ Hartford Street	EBLT	7	11	64%	27	17	
	EBRT	4		36%		10	
	NBLT	5		1%		12	
	NBTH	774	794	97%		1911	
	NBRT	15	58	2%		1960	37
	WBLT	15		26%		35	
	WBRT	43	74%	137		102	
	SBLT	38	2160	2%		3965	70
	SBTH	2120		98%			3892
	SBRT	2		0%			4
US 41 @ Causeway Boulevard	EBLT	61	2099	3%	4093	119	
	EBTH	821		39%		1601	
	EBRT	1217		58%		2373	
	NBLT	410	909	45%		2204	994
	NBTH	396		44%			960
	NBRT	103	11%	250			
	WBLT	55	545	10%		1873	189
	WBTH	343		63%			1179
	WBRT	147		27%			505
	SBLT	223	1039	21%		3150	676
	SBTH	797		77%			2416
	SBRT	19		2%			58



**APPENDIX I**  
**DEVELOPMENT OF FUTURE TRAFFIC VOLUMES**

US 41 MAINLINE

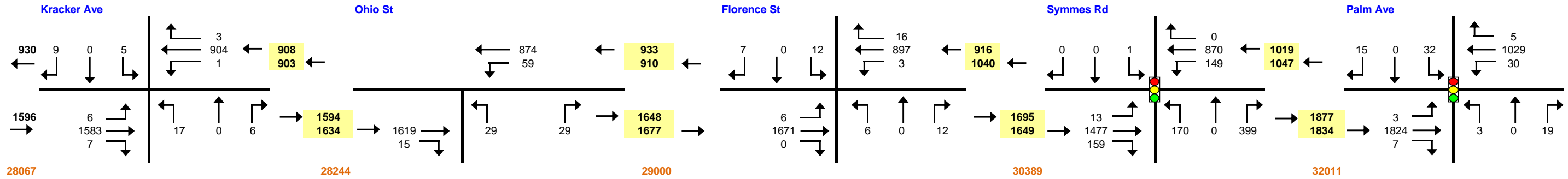

US 41 MAINLINE

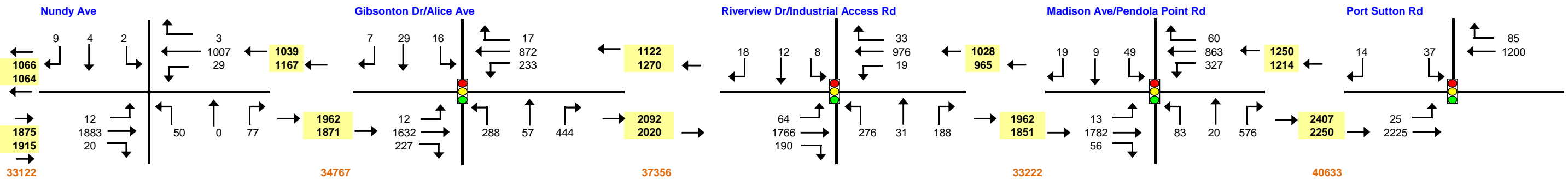

US 41 MAINLINE

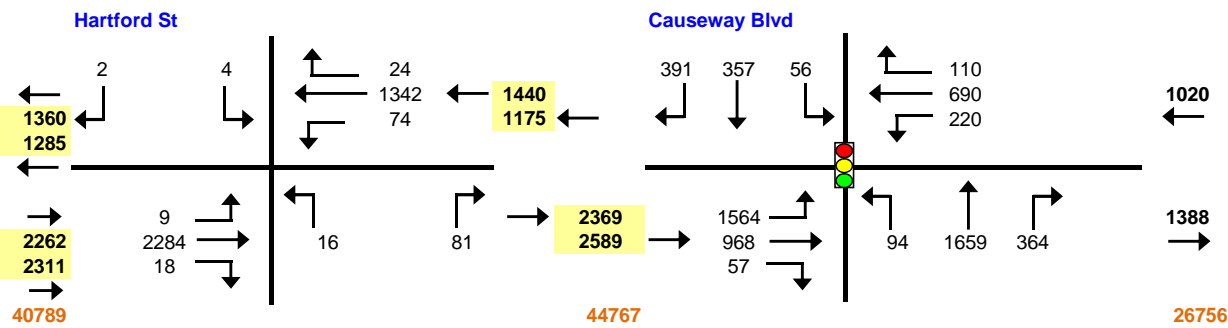

LEGEND	
	Signalized Intersection

**US 41 PD&E**  
 from Kracker Avenue to South of Causeway Boulevard  
 Hillsborough County, Florida

**ORIGINAL OPENING YEAR 2020 AM PEAK HOUR TRAFFIC VOLUMES**

US 41 MAINLINE

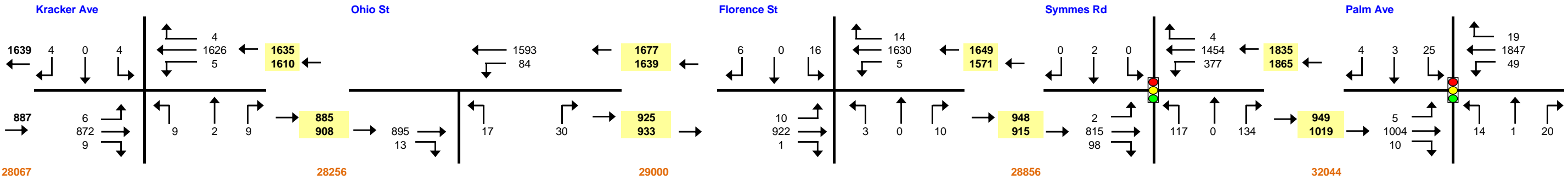

US 41 MAINLINE

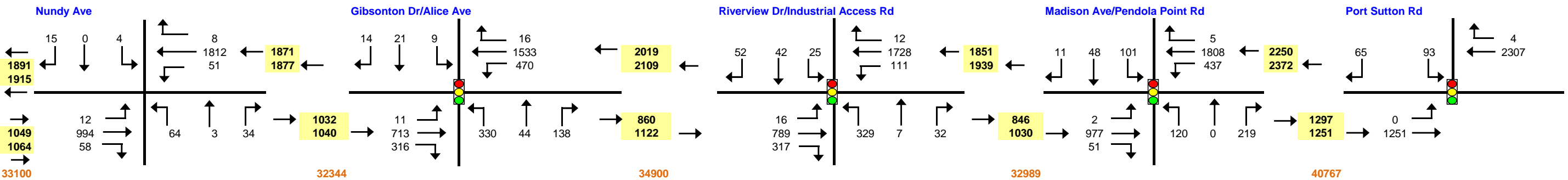

US 41 MAINLINE

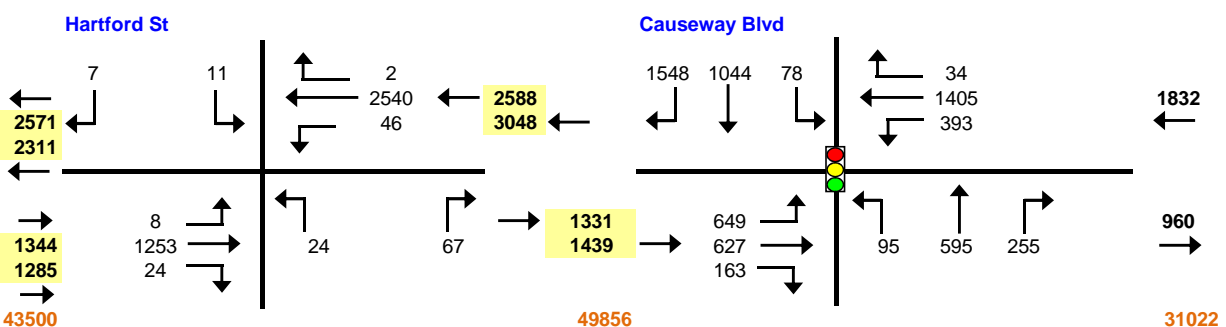

**LEGEND**

Signalized Intersection

US 41 PD&E  
 from Kracker Avenue to South of Causeway Boulevard  
 Hillsborough County, Florida

ORIGINAL OPENING YEAR 2020 PM PEAK HOUR TRAFFIC VOLUMES

US 41 MAINLINE

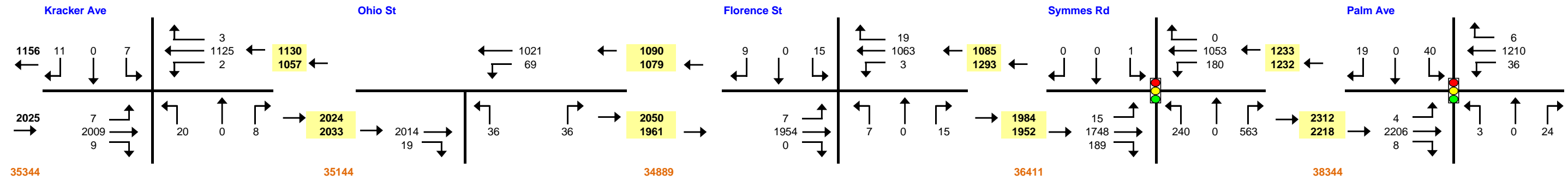

US 41 MAINLINE

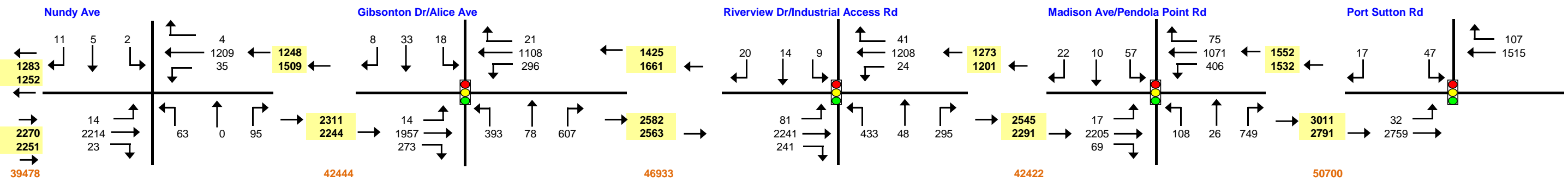

US 41 MAINLINE

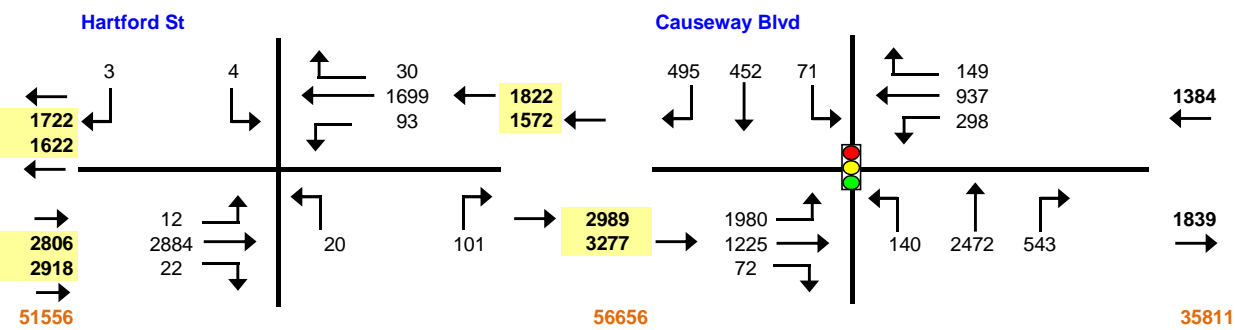

**LEGEND**

Signalized Intersection

US 41 PD&E  
 from Kracker Avenue to South of Causeway Boulevard  
 Hillsborough County, Florida

ORIGINAL INTERIM YEAR 2030 AM PEAK HOUR TRAFFIC VOLUMES

US 41 MAINLINE

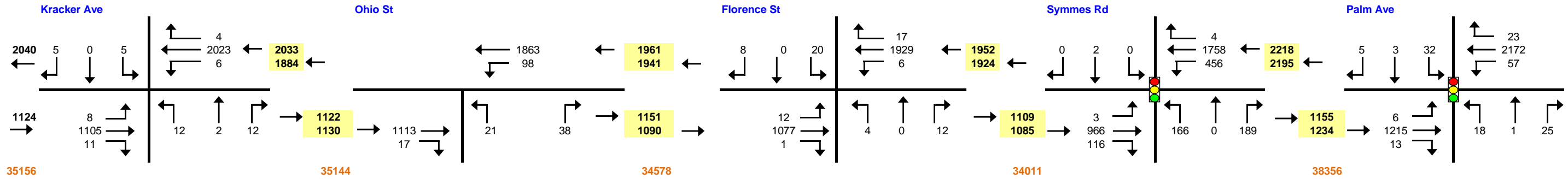

US 41 MAINLINE

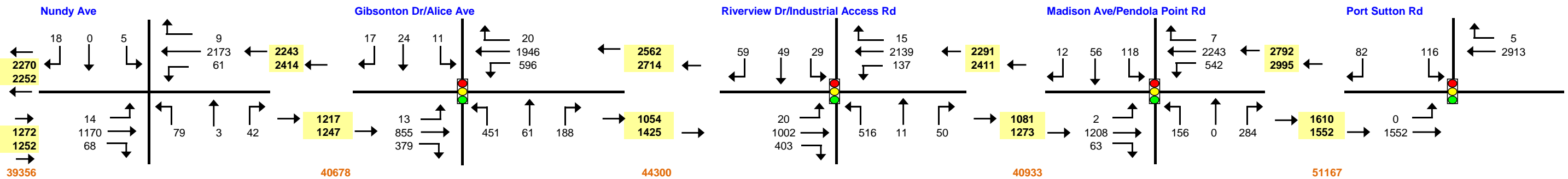

US 41 MAINLINE

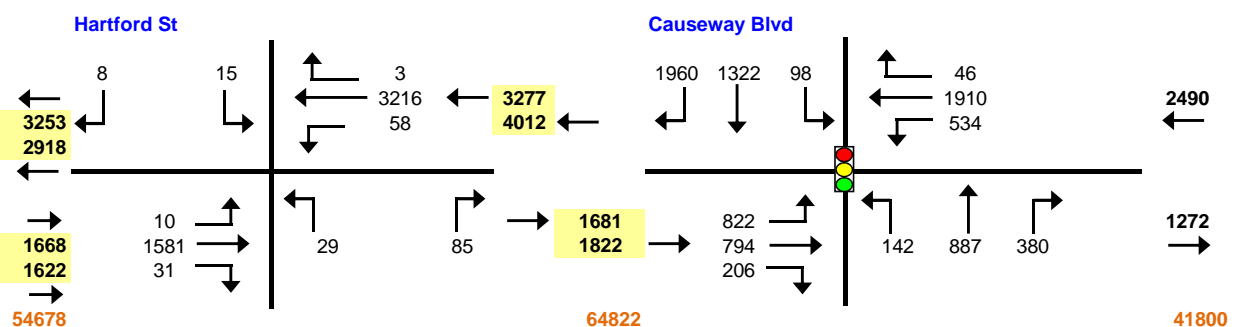

**LEGEND**

Signalized Intersection

US 41 PD&E  
 from Kracker Avenue to South of Causeway Boulevard  
 Hillsborough County, Florida

ORIGINAL INTERIM YEAR 2030 PM PEAK HOUR TRAFFIC VOLUMES

US 41 MAINLINE

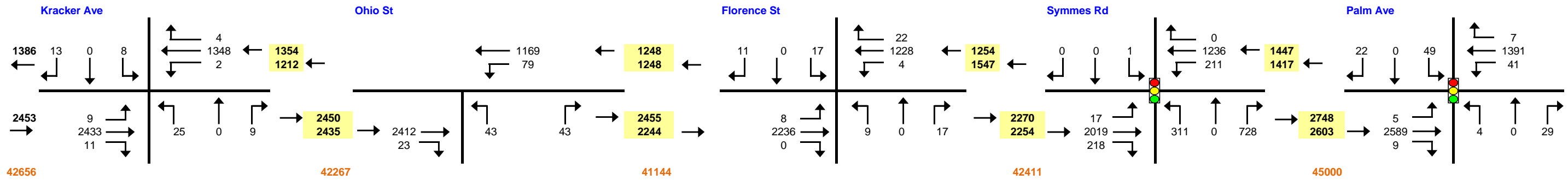

US 41 MAINLINE

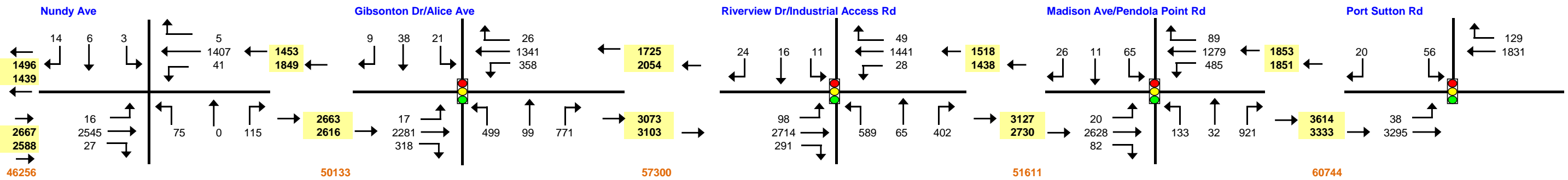

US 41 MAINLINE

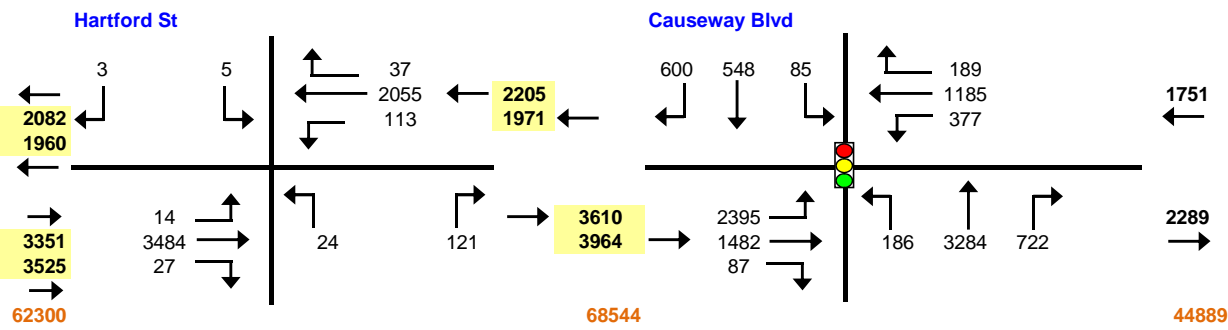

**LEGEND**

 Signalized Intersection

**US 41 PD&E**  
 from Kracker Avenue to South of Causeway Boulevard  
 Hillsborough County, Florida

**ORIGINAL DESIGN YEAR 2040 AM PEAK HOUR TRAFFIC VOLUMES**

US 41 MAINLINE

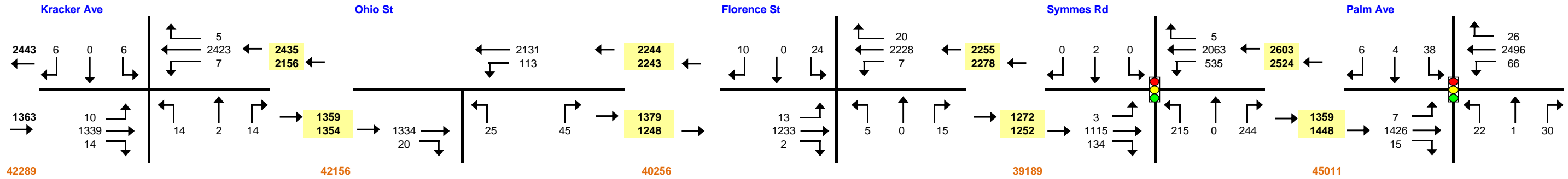

US 41 MAINLINE

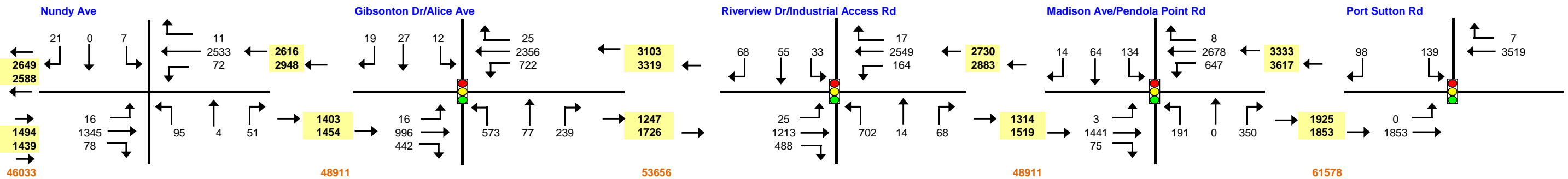

US 41 MAINLINE

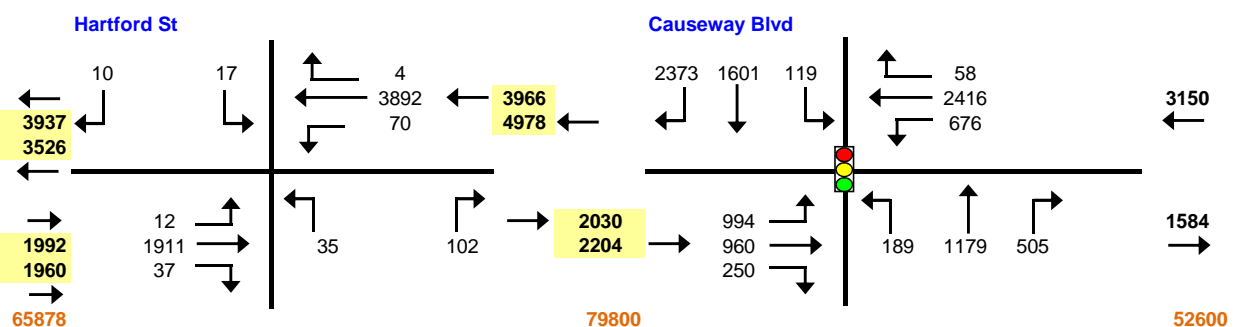

**LEGEND**

 Signalized Intersection

US 41 PD&E  
 from Kracker Avenue to South of Causeway Boulevard  
 Hillsborough County, Florida

ORIGINAL DESIGN YEAR 2040 PM PEAK HOUR TRAFFIC VOLUMES

May 14, 2013

Waddah Farah  
Florida Department of Transportation  
District 7  
11201 N. McKinley Drive  
Tampa, Florida 33612

Re: US 41 PD&E Study from Kracker Avenue to South of SR 676 (Causeway Boulevard)  
FPN: 430056-1-22-01  
Recommended Design Hour Traffic Factors and Development of Existing and Future Traffic  
Volumes  
Response to FDOT Comments (5-3-2013)

Dear Mr. Farah:

American has reviewed the FDOT comments for the Recommended Design Hour Traffic Factors & Development of Existing Traffic Volumes Document received on May 3, 2013 and we offer the following responses:

Comment 1: Figure 1 – Existing Lane Geometry: The intersection of US 41 / Kracker Avenue does not show the existing EB & WB exclusive right turn lanes. Please confirm the existing lane geometry at this intersection.

**Response:** *Figure 1 will be revised to show exclusive EB and WB right turn lanes at the intersection of US 41 and Kracker Avenue.*

Comment 2: Figure 1: Existing Lane Geometry: Recommend showing the railroad crossings at the intersections of US 41 / Gibsonton Avenue and US 41 / Riverview Drive.

**Response:** *Figure 1 will be revised to show the railroad crossings at the intersections of US 41 and Gibsonton Drive and US 41 and Riverview Drive.*

Comment 3: Figure 1 – Existing Lane Geometry: Please include rail road crossings in the legend.

**Response:** *Figure 1 will be revised to include railroad crossings in the legend.*



Comment 4: Page 7 – Development of Future Traffic Volumes and Appendix G: Since the major side streets will grow at a different rate than the minor side streets, please consider developing the future side street volumes as follows:

1. For the major side streets such as Causeway Boulevard, Madison Avenue, Gibsonton Drive, Riverview Drive and Symmes Road, please use the same methodology as was used to develop the US 41 mainline volumes using the latest version of the TBRPM travel demand forecasting model.
2. For the other side streets such as Kracker Avenue, Ohio Street, Florence Street, Palm Avenue, Nundy Avenue, Port Sutton Road and Hartford Street, please review the socioeconomic data (housing, population and/or employment) within the traffic analysis zones immediately adjacent to the individual side street for the validation year (2006) and the year 2035-to develop the growth rate. For some side streets a minimum 1% growth rate will be appropriate. If you have any questions on the side street growth rate issue, please contact myself or Fawzi Bitar.
3. It is recommended that you provide Fawzi Bitar and Andrew Tyrell and myself with the results of the side street annual growth rates prior to submitting any analysis.

**Response:** *1. For the major side-streets including Causeway Boulevard, Madison Avenue, Gibsonton Drive, Riverview Drive and Symmes Road, the same methodology of developing future forecasts as was used for US 41 mainline volumes will be used involving latest version of TBRPM volumes. This was discussed with Fawzi Bitar (FDOT-District 7) on May 6, 2013.*

*2. For the minor side-streets including Hartford Street, Port Sutton Road, Nundy Avenue, Palm Avenue, Florence Street, Ohio Street and Kracker Avenue, socioeconomic data will be reviewed for the traffic analysis zones adjacent to these individual side-streets for validation base year (2006) and future year (2035) to develop the growth rate. Average of the growth rates for all the minor side-streets will be used for all minor side-streets for the purpose of traffic forecasting. This was discussed with Fawzi Bitar (FDOT-District 7) on May 6, 2013. The same methodology will be applied for the minor approaches of the major side-streets which are not included in the model.*

*3. The proposed future traffic for the major side-streets and the proposed growth rate for the minor side-streets and minor approaches of the major side-streets will be submitted to David Winkle, Fawzi Bitar and Andrew Tyrell at FDOT-District 7 prior to developing and re-submitting the future volumes.*

If you have any questions, please feel free to contact me at 813-435-2565 or Arpita Guha at 813-435-2618.

Sincerely,

*American Consulting Engineers of Florida, LLC*



Akram Hussein, P.E., PTOE

cc: David Winkle, FDOT-D7  
Peter Maass, FDOT-D7  
Fawzi Bitar, FDOT-D7  
Andrew Tyrell, FDOT-D7  
Rick Adair, FDOT-D7  
Jeff Novotny, American  
Larry Weatherby, American  
Arpita Guha, American  
David Bredahl, American

# Appendix C

## Existing Signal Timings

Hillsborough County

Timing Sheet

4/19/2012 8:50:57 AM

Station : 1466 - US 41 & Symmes Rd (F306) ( Standard File )

Phase [1.1.1]

	1	2 (ST)	3	4 (WT)	5 (SL)	6 (NT)	7	8 (ET)	9	10	11	12	13	14	15	16
Walk				7		7										
Ped Clearance				32		27										
Min Green		15		7	5	15		7								
Passage		4		3	3	4		3								
Max1		65		20	15	50		20								
Max2																
Yellow	9	4.7	9	3.6	4.7	4.7	9	3.6	9	9	9	9	9	9	9	9
Red		1.5		3.6	2.3	1.5		3.6								
Red Revert		3		3	3	3		3								
Added Initial																
Max Initial																
Time Before Reduce																
Cars Before Reduce																
Time To Reduce																
Reduce By																
Min Gap																
Dynamic Max Limit																
Dynamic Max Step																
Auto Exit		ON				ON										
Rest In Walk																

Phase Option [1.1.2]

	1	2 (ST)	3	4 (WT)	5 (SL)	6 (NT)	7	8 (ET)	9	10	11	12	13	14	15	16
Enable		ON		ON	ON	ON		ON								
Auto Entry				ON				ON								
Non Act1																
Non Act2																
Lock Call																
Min Recall		ON				ON										
Max Recall																
Ped Recall																
Soft Recall																
Dual Entry		ON		ON		ON		ON								
Sim Gap Enable	ON	ON	ON	ON	ON	ON	ON	ON								
Guar Passage																
Cond Service																
Add Init Calc																

Alternate Phase Program 1, Calls and Redirection [1.1.6.3]

Entry	Call Phases	From	To	From	To	From	To	From	To	Assigned Ph
1										
2										
3										
4										
5										
6										
7										
8										

Alternate Phase Program 2, Calls and Redirection [1.1.6.3]

Entry	Call Phases	From	To	From	To	From	To	From	To	Assigned Ph
1										
2										
3										
4										
5										
6										
7										
8										

Alternate Phase Program 1, Interval Times [1.1.6.1]

Phase	Walk	Ped Clear	Min Green	Passage	Max1	Max2	Yellow	Red Clear	Assign Ph	Bike Clear
1										
2										
3										
4										
5										
6										
7										
8										

Alternate Phase Program 2, Interval Times [1.1.6.1]

Phase	Walk	Ped Clear	Min Green	Passage	Max1	Max2	Yellow	Red Clear	Assign Ph	Bike Clear
1										
2										
3										
4										
5										
6										
7										
8										

Prepared By

Date Implemented

Reviewed By

Traffic Engineer



Hillsborough County

Timing Sheet

4/19/2012 8:50:57 AM

Station : 1466 - US 41 & Symmes Rd (F306) ( Standard File )

**Detector Alternate Program 1, Vehicle Parameters [5.5.1]**

	1 (SBT1)	2 (SBT2)	3 (WBT1)	4 (SBL1)	5 (NBT1)	6 (NBT2)	7 (WBL1)	8 (EBT1)	9	10	11	12	13	14	15	16
Call Phase																
Switch Phase																
Delay Time																

**Channels/SDLC, Assign to Phases [1.3.1]**

	1	2	3	4	5	6	7	8	9	10	11	12	13	14	15	16	17	18	19	20	21	22	23	24
PH/OLP #	1	2	3	4	5	6	7	8	1	2	3	4	2	4	6	8								
Type	VEH	VEH	VEH	VEH	VEH	VEH	VEH	VEH	OLP	OLP	OLP	OLP	PED	PED	PED	PED	OTH	OTH	OTH	OTH	OTH	OTH	OTH	OTH
Flash	RED	YEL	RED	RED	RED	YEL	RED	RED	RED	RED	RED	RED	DRK	DRK	DRK	DRK	DRK	DRK	DRK	DRK	DRK	DRK	DRK	DRK
Flash 1-2 Hertz																								
Dimming Green																								
Dimming Yellow																								
Dimming Red																								
Alt Cyc	+	+	+	+	+	+	+	+	+	+	+	+	+	+	+	+	+	+	+	+	+	+	+	+

**Channel/SDLC, Parameters [1.3.3]**

TOD Dim Enable	Extra Maps Enable	D Connector Enable	Single BIU Map	IO Mode	Preempt or Ext Output
OFF	DEFAULT	NONE	ON	AUTO	EXT

**Channel/SDLC, MMU Map [1.3.5]**

**MMU-to-Controller Channel Map**

1	2	3	4	5	6	7	8	9	10	11	12	13	14	15	16
1	2	3	4	5	6	7	8	9	10	11	12	13	14	15	16

**Channel/SDLC, Permissive [1.3.4]**

Channel	16	15	14	13	12	11	10	9	8	7	6	5	4	3	2
1															
2		1									1	1			
3															
4			1						1						
5															
6		1													
7															
8			1												
9															
10															
11															
12															
13															
14															
15															

**Channel/SDLC, Permissive [1.3.7]**

SDLC Device	Term/Fac								Detector								MMU	Diag
BIU#	1	2	3	4	5	6	7	8	1	2	3	4	5	6	7	8		
Present	ON	ON							ON									ON
Peer to Peer																		



















Hillsborough County

Timing Sheet

4/19/2012 8:47:00 AM

Station : 1369 - Palm Ave & US 41 (F033) ( Standard File )

Phase [1.1.1]

	1 (SL)	2 (NT)	3	4 (WT)	5	6	7	8	9	10	11	12	13	14	15	16
Walk		7		10												
Ped Clearance		13		32												
Min Green	5	15		7												
Passage	2.5	4		3												
Max1	15	60		15												
Max2																
Yellow	4.7	4.7	9	3	9	9	9	9	9	9	9	9	9	9	9	9
Red	1.8	1.5		3.7												
Red Revert	3	3	3	3	3	3	3	3	3	3	3	3	3	3	3	3
Added Initial																
Max Initial																
Time Before Reduce																
Cars Before Reduce																
Time To Reduce																
Reduce By																
Min Gap																
Dynamic Max Limit																
Dynamic Max Step																
Auto Exit		ON														
Rest In Walk																

Phase Option [1.1.2]

	1 (SL)	2 (NT)	3	4 (WT)	5	6	7	8	9	10	11	12	13	14	15	16
Enable	ON	ON		ON												
Auto Entry				ON												
Non Act1																
Non Act2																
Lock Call																
Min Recall		ON														
Max Recall																
Ped Recall																
Soft Recall																
Dual Entry																
Sim Gap Enable																
Guar Passage																
Cond Service																
Add Init Calc																

Alternate Phase Program 1, Calls and Redirection [1.1.6.3]

Entry	Call Phases	From	To	From	To	From	To	From	To	Assigned Ph
1										
2										
3										
4										
5										
6										
7										
8										

Alternate Phase Program 2, Calls and Redirection [1.1.6.3]

Entry	Call Phases	From	To	From	To	From	To	From	To	Assigned Ph
1										
2										
3										
4										
5										
6										
7										
8										

Alternate Phase Program 1, Interval Times [1.1.6.1]

Phase	Walk	Ped Clear	Min Green	Passage	Max1	Max2	Yellow	Red Clear	Assign Ph	Bike Clear
1										
2										
3										
4										
5										
6										
7										
8										

Alternate Phase Program 2, Interval Times [1.1.6.1]

Phase	Walk	Ped Clear	Min Green	Passage	Max1	Max2	Yellow	Red Clear	Assign Ph	Bike Clear
1										
2										
3										
4										
5										
6										
7										
8										

Prepared By

Date Implemented

Reviewed By

Traffic Engineer





Hillsborough County

Timing Sheet

4/19/2012 8:47:00 AM

Station : 1369 - Palm Ave & US 41 (F033) ( Standard File )

**Detector Alternate Program 1, Vehicle Parameters [5.5.1]**

	1	2	3	4	5	6	7	8	9	10	11	12	13	14	15	16
Call Phase																
Switch Phase																
Delay Time																

**Channels/SDLC, Assign to Phases [1.3.1]**

	1	2	3	4	5	6	7	8	9	10	11	12	13	14	15	16	17	18	19	20	21	22	23	24
PH/OLP #	1	2	4						1				2	4										
Type	VEH	VEH	VEH	VEH	VEH	VEH	VEH	VEH	OLP	OLP	OLP	OLP	PED	PED	PED	PED	OTH	OTH	OTH	OTH	OTH	OTH	OTH	OTH
Flash	RED	YEL	RED	RED	RED	RED	RED	RED	YEL	RED	RED	RED	DRK	DRK	DRK	DRK	DRK	DRK	DRK	DRK	DRK	DRK	DRK	DRK
Flash 1-2 Hertz																								
Dimming Green																								
Dimming Yellow																								
Dimming Red																								
Alt Cyc	+	+	+	+	+	+	+	+	+	+	+	+	+	+	+	+	+	+	+	+	+	+	+	+

**Channel/SDLC, Parameters [1.3.3]**

TOD Dim Enable	Extra Maps Enable	D Connector Enable	Single BIU Map	IO Mode	Preempt or Ext Output
OFF	DEFAULT	TX2_V14	ON	AUTO	EXT

**Channel/SDLC, MMU Map [1.3.5]**

**MMU-to-Controller Channel Map**

1	2	3	4	5	6	7	8	9	10	11	12	13	14	15	16
1	2	3	4	5	6	7	8	9	10	11	12	13	14	15	16

**Channel/SDLC, Permissive [1.3.4]**

Channel	16	15	14	13	12	11	10	9	8	7	6	5	4	3	2
1															
2															
3															
4															
5															
6															
7															
8															
9															
10															
11															
12															
13															
14															
15															

**Channel/SDLC, Permissive [1.3.7]**

SDLC Device	Term/Fac	Detector								MMU	Diag
		1	2	3	4	5	6	7	8		
BIU#											
Present											
Peer to Peer											



















Hillsborough County

Timing Sheet

4/19/2012 8:45:07 AM

Station : 1339 - Alice Ave & US 41 (E003) ( Standard File )

Phase [1.1.1]

	1	2 (ST)	3	4 (WT)	5 (SL)	6 (NT)	7	8 (ET)	9	10	11	12	13	14	15	16
Walk		7		7		7		7								
Ped Clearance		14		32		23		36								
Min Green		15		7	5	15		7								
Passage		8		6	3	8		3								
Max1		60		20	15	60		20								
Max2																
Yellow	9	4.7	9	4.3	4.7	4.7	9	4.3	9	9	9	9	9	9	9	9
Red		1.4		4.7	2	1.4		4.7								
Red Revert	3	3	3	3	3	3	3	3	3	3	3	3	3	3	3	3
Added Initial																
Max Initial																
Time Before Reduce		15		10		15										
Cars Before Reduce																
Time To Reduce		15		10		15										
Reduce By																
Min Gap		4		4		4										
Dynamic Max Limit																
Dynamic Max Step																
Auto Exit		ON				ON										
Rest In Walk																

Phase Option [1.1.2]

	1	2 (ST)	3	4 (WT)	5 (SL)	6 (NT)	7	8 (ET)	9	10	11	12	13	14	15	16
Enable		ON		ON	ON	ON		ON								
Auto Entry				ON				ON								
Non Act1																
Non Act2																
Lock Call																
Min Recall		ON				ON										
Max Recall																
Ped Recall																
Soft Recall																
Dual Entry		ON		ON		ON		ON								
Sim Gap Enable		ON		ON	ON	ON		ON								
Guar Passage																
Cond Service																
Add Init Calc																

Alternate Phase Program 1, Calls and Redirection [1.1.6.3]

Entry	Call Phases	From	To	From	To	From	To	From	To	Assigned Ph
1										
2										
3										
4										
5										
6										
7										
8										

Alternate Phase Program 2, Calls and Redirection [1.1.6.3]

Entry	Call Phases	From	To	From	To	From	To	From	To	Assigned Ph
1										
2										
3										
4										
5										
6										
7										
8										

Alternate Phase Program 1, Interval Times [1.1.6.1]

Phase	Walk	Ped Clear	Min Green	Passage	Max1	Max2	Yellow	Red Clear	Assign Ph	Bike Clear
1										
2										
3										
4										
5										
6										
7										
8										

Alternate Phase Program 2, Interval Times [1.1.6.1]

Phase	Walk	Ped Clear	Min Green	Passage	Max1	Max2	Yellow	Red Clear	Assign Ph	Bike Clear
1										
2										
3										
4										
5										
6										
7										
8										

Prepared By

Date Implemented

Reviewed By

Traffic Engineer



Hillsborough County

Timing Sheet

4/19/2012 8:45:07 AM

Station : 1339 - Alice Ave & US 41 (E003) ( Standard File )

**Detector Alternate Program 1, Vehicle Parameters [5.5.1]**

	1	2	3	4	5	6	7	8	9	10	11	12	13	14	15	16
Call Phase																
Switch Phase																
Delay Time																

**Channels/SDLC, Assign to Phases [1.3.1]**

	1	2	3	4	5	6	7	8	9	10	11	12	13	14	15	16	17	18	19	20	21	22	23	24	
PH/OLP #		2		4	5	6		8					2	4	6	8									
Type	VEH	VEH	VEH	VEH	VEH	VEH	VEH	VEH	OLP	OLP	OLP	OLP	PED	PED	PED	PED	OTH	OTH	OTH	OTH	OTH	OTH	OTH	OTH	
Flash	RED	YEL	RED	RED	RED	YEL	RED	RED	RED	RED	RED	RED	DRK	DRK	DRK	DRK	DRK	DRK	DRK	DRK	DRK	DRK	DRK	DRK	
Flash 1-2 Hertz																									
Dimming Green																									
Dimming Yellow																									
Dimming Red																									
Alt Cyc	+	+	+	+	+	+	+	+	+	+	+	+	+	+	+	+	+	+	+	+	+	+	+	+	

**Channel/SDLC, Parameters [1.3.3]**

TOD Dim Enable	Extra Maps Enable	D Connector Enable	Single BIU Map	IO Mode	Preempt or Ext Output
OFF	DEFAULT	TX2_V14	ON	AUTO	EXT

**Channel/SDLC, MMU Map [1.3.5]**

**MMU-to-Controller Channel Map**

1	2	3	4	5	6	7	8	9	10	11	12	13	14	15	16
1	2	3	4	5	6	7	8	9	10	11	12	13	14	15	16

**Channel/SDLC, Permissive [1.3.4]**

Channel	16	15	14	13	12	11	10	9	8	7	6	5	4	3	2
1															
2															
3															
4															
5															
6															
7															
8															
9															
10															
11															
12															
13															
14															
15															

**Channel/SDLC, Permissive [1.3.7]**

SDLC Device	Term/Fac	Detector								MMU	Diag
		1	2	3	4	5	6	7	8		
BIU#											
Present											
Peer to Peer											



















Hillsborough County

Timing Sheet

4/19/2012 8:48:48 AM

Station : 1375 - Riverview Dr & US 41 (E019) ( Standard File )

Phase [1.1.1]

	1	2 (ST)	3	4 (WT)	5	6	7	8	9	10	11	12	13	14	15	16
Walk																
Ped Clearance																
Min Green		15		7												
Passage		8		6												
Max1		45		25												
Max2																
Yellow	9	4.7	9	3.6	9	9	9	9	9	9	9	9	9	9	9	9
Red		1.7		2.7												
Red Revert	3	3	3	3	3	3	3	3	3	3	3	3	3	3	3	3
Added Initial																
Max Initial																
Time Before Reduce		15		10												
Cars Before Reduce																
Time To Reduce		15		10												
Reduce By																
Min Gap		4		3												
Dynamic Max Limit																
Dynamic Max Step																
Auto Exit		ON														
Rest In Walk																

Phase Option [1.1.2]

	1	2 (ST)	3	4 (WT)	5	6	7	8	9	10	11	12	13	14	15	16
Enable		ON		ON												
Auto Entry				ON												
Non Act1																
Non Act2																
Lock Call																
Min Recall		ON														
Max Recall																
Ped Recall																
Soft Recall																
Dual Entry																
Sim Gap Enable																
Guar Passage																
Cond Service																
Add Init Calc																

Alternate Phase Program 1, Calls and Redirection [1.1.6.3]

Entry	Call Phases	From	To	From	To	From	To	From	To	Assigned Ph
1										
2										
3										
4										
5										
6										
7										
8										

Alternate Phase Program 2, Calls and Redirection [1.1.6.3]

Entry	Call Phases	From	To	From	To	From	To	From	To	Assigned Ph
1										
2										
3										
4										
5										
6										
7										
8										

Alternate Phase Program 1, Interval Times [1.1.6.1]

Phase	Walk	Ped Clear	Min Green	Passage	Max1	Max2	Yellow	Red Clear	Assign Ph	Bike Clear
1										
2										
3										
4										
5										
6										
7										
8										

Alternate Phase Program 2, Interval Times [1.1.6.1]

Phase	Walk	Ped Clear	Min Green	Passage	Max1	Max2	Yellow	Red Clear	Assign Ph	Bike Clear
1										
2										
3										
4										
5										
6										
7										
8										

Prepared By

Date Implemented

Reviewed By

Traffic Engineer



Hillsborough County

Timing Sheet

4/19/2012 8:48:48 AM

Station : 1375 - Riverview Dr & US 41 (E019) ( Standard File )

**Detector Alternate Program 1, Vehicle Parameters [5.5.1]**

	1	2	3	4	5	6	7	8	9	10	11	12	13	14	15	16
Call Phase																
Switch Phase																
Delay Time																

**Channels/SDLC, Assign to Phases [1.3.1]**

	1	2	3	4	5	6	7	8	9	10	11	12	13	14	15	16	17	18	19	20	21	22	23	24
PH/OLP #		2		4					1	2														
Type	VEH	VEH	VEH	VEH	VEH	VEH	VEH	VEH	VEH	VEH	VEH	VEH	VEH	VEH	VEH	VEH	VEH	VEH	VEH	VEH	VEH	VEH	VEH	VEH
Flash	RED	YEL	RED	RED	RED	RED	RED	RED	RED	RED	RED	RED	RED	DRK	DRK	DRK	DRK	DRK	DRK	DRK	DRK	DRK	DRK	DRK
Flash 1-2 Hertz																								
Dimming Green																								
Dimming Yellow																								
Dimming Red																								
Alt Cyc	+	+	+	+	+	+	+	+	+	+	+	+	+	+	+	+	+	+	+	+	+	+	+	+

**Channel/SDLC, Parameters [1.3.3]**

TOD Dim Enable	Extra Maps Enable	D Connector Enable	Single BIU Map	IO Mode	Preempt or Ext Output
OFF	DEFAULT	TX2_V14	ON	AUTO	EXT

**Channel/SDLC, MMU Map [1.3.5]**

**MMU-to-Controller Channel Map**

1	2	3	4	5	6	7	8	9	10	11	12	13	14	15	16
1	2	3	4	5	6	7	8	9	10	11	12	13	14	15	16

**Channel/SDLC, Permissive [1.3.4]**

Channel	16	15	14	13	12	11	10	9	8	7	6	5	4	3	2
1															
2															
3															
4															
5															
6															
7															
8															
9															
10															
11															
12															
13															
14															
15															

**Channel/SDLC, Permissive [1.3.7]**

SDLC Device	Term/Fac	Detector								MMU	Diag					
BIU#	1	2	3	4	5	6	7	8	1	2	3	4	5	6	7	8
Present																
Peer to Peer																









Hillsborough County

Timing Sheet

4/19/2012 8:48:48 AM

Station : 1375 - Riverview Dr &amp; US 41 (E019) ( Standard File )

<b>Split Table 13</b>	<b>1</b>	<b>2</b>	<b>3</b>	<b>4</b>	<b>5</b>	<b>6</b>	<b>7</b>	<b>8</b>	<b>9</b>	<b>10</b>	<b>11</b>	<b>12</b>	<b>13</b>	<b>14</b>	<b>15</b>	<b>16</b>
Time																
Mode	NON	NON	NON	NON	NON	NON	NON	NON	OMT	OMT	OMT	OMT	OMT	OMT	OMT	OMT
Coord-Ph																

<b>Split Table 14</b>	<b>1</b>	<b>2</b>	<b>3</b>	<b>4</b>	<b>5</b>	<b>6</b>	<b>7</b>	<b>8</b>	<b>9</b>	<b>10</b>	<b>11</b>	<b>12</b>	<b>13</b>	<b>14</b>	<b>15</b>	<b>16</b>
Time																
Mode	NON	NON	NON	NON	NON	NON	NON	NON	OMT	OMT	OMT	OMT	OMT	OMT	OMT	OMT
Coord-Ph																

<b>Split Table 15</b>	<b>1</b>	<b>2</b>	<b>3</b>	<b>4</b>	<b>5</b>	<b>6</b>	<b>7</b>	<b>8</b>	<b>9</b>	<b>10</b>	<b>11</b>	<b>12</b>	<b>13</b>	<b>14</b>	<b>15</b>	<b>16</b>
Time																
Mode	NON	NON	NON	NON	NON	NON	NON	NON	OMT	OMT	OMT	OMT	OMT	OMT	OMT	OMT
Coord-Ph																

<b>Split Table 16</b>	<b>1</b>	<b>2</b>	<b>3</b>	<b>4</b>	<b>5</b>	<b>6</b>	<b>7</b>	<b>8</b>	<b>9</b>	<b>10</b>	<b>11</b>	<b>12</b>	<b>13</b>	<b>14</b>	<b>15</b>	<b>16</b>
Time																
Mode	NON	NON	NON	NON	NON	NON	NON	NON	OMT	OMT	OMT	OMT	OMT	OMT	OMT	OMT
Coord-Ph																

<b>Split Table 17</b>	<b>1</b>	<b>2</b>	<b>3</b>	<b>4</b>	<b>5</b>	<b>6</b>	<b>7</b>	<b>8</b>	<b>9</b>	<b>10</b>	<b>11</b>	<b>12</b>	<b>13</b>	<b>14</b>	<b>15</b>	<b>16</b>
Time																
Mode	NON	NON	NON	NON	NON	NON	NON	NON	OMT	OMT	OMT	OMT	OMT	OMT	OMT	OMT
Coord-Ph																

<b>Split Table 18</b>	<b>1</b>	<b>2</b>	<b>3</b>	<b>4</b>	<b>5</b>	<b>6</b>	<b>7</b>	<b>8</b>	<b>9</b>	<b>10</b>	<b>11</b>	<b>12</b>	<b>13</b>	<b>14</b>	<b>15</b>	<b>16</b>
Time																
Mode	NON	NON	NON	NON	NON	NON	NON	NON	OMT	OMT	OMT	OMT	OMT	OMT	OMT	OMT
Coord-Ph																

<b>Split Table 19</b>	<b>1</b>	<b>2</b>	<b>3</b>	<b>4</b>	<b>5</b>	<b>6</b>	<b>7</b>	<b>8</b>	<b>9</b>	<b>10</b>	<b>11</b>	<b>12</b>	<b>13</b>	<b>14</b>	<b>15</b>	<b>16</b>
Time																
Mode	NON	NON	NON	NON	NON	NON	NON	NON	OMT	OMT	OMT	OMT	OMT	OMT	OMT	OMT
Coord-Ph																

<b>Split Table 20</b>	<b>1</b>	<b>2</b>	<b>3</b>	<b>4</b>	<b>5</b>	<b>6</b>	<b>7</b>	<b>8</b>	<b>9</b>	<b>10</b>	<b>11</b>	<b>12</b>	<b>13</b>	<b>14</b>	<b>15</b>	<b>16</b>
Time																
Mode	NON	NON	NON	NON	NON	NON	NON	NON	OMT	OMT	OMT	OMT	OMT	OMT	OMT	OMT
Coord-Ph																

<b>Split Table 21</b>	<b>1</b>	<b>2</b>	<b>3</b>	<b>4</b>	<b>5</b>	<b>6</b>	<b>7</b>	<b>8</b>	<b>9</b>	<b>10</b>	<b>11</b>	<b>12</b>	<b>13</b>	<b>14</b>	<b>15</b>	<b>16</b>
Time																
Mode	NON	NON	NON	NON	NON	NON	NON	NON	OMT	OMT	OMT	OMT	OMT	OMT	OMT	OMT
Coord-Ph																

<b>Split Table 22</b>	<b>1</b>	<b>2</b>	<b>3</b>	<b>4</b>	<b>5</b>	<b>6</b>	<b>7</b>	<b>8</b>	<b>9</b>	<b>10</b>	<b>11</b>	<b>12</b>	<b>13</b>	<b>14</b>	<b>15</b>	<b>16</b>
Time																
Mode	NON	NON	NON	NON	NON	NON	NON	NON	OMT	OMT	OMT	OMT	OMT	OMT	OMT	OMT
Coord-Ph																

<b>Split Table 23</b>	<b>1</b>	<b>2</b>	<b>3</b>	<b>4</b>	<b>5</b>	<b>6</b>	<b>7</b>	<b>8</b>	<b>9</b>	<b>10</b>	<b>11</b>	<b>12</b>	<b>13</b>	<b>14</b>	<b>15</b>	<b>16</b>
Time																
Mode	NON	NON	NON	NON	NON	NON	NON	NON	OMT	OMT	OMT	OMT	OMT	OMT	OMT	OMT
Coord-Ph																

<b>Split Table 24</b>	<b>1</b>	<b>2</b>	<b>3</b>	<b>4</b>	<b>5</b>	<b>6</b>	<b>7</b>	<b>8</b>	<b>9</b>	<b>10</b>	<b>11</b>	<b>12</b>	<b>13</b>	<b>14</b>	<b>15</b>	<b>16</b>
Time																
Mode	NON	NON	NON	NON	NON	NON	NON	NON	OMT	OMT	OMT	OMT	OMT	OMT	OMT	OMT
Coord-Ph																

<b>Split Table 25</b>	<b>1</b>	<b>2</b>	<b>3</b>	<b>4</b>	<b>5</b>	<b>6</b>	<b>7</b>	<b>8</b>	<b>9</b>	<b>10</b>	<b>11</b>	<b>12</b>	<b>13</b>	<b>14</b>	<b>15</b>	<b>16</b>
Time																
Mode	NON	NON	NON	NON	NON	NON	NON	NON	OMT	OMT	OMT	OMT	OMT	OMT	OMT	OMT
Coord-Ph																

<b>Split Table 26</b>	<b>1</b>	<b>2</b>	<b>3</b>	<b>4</b>	<b>5</b>	<b>6</b>	<b>7</b>	<b>8</b>	<b>9</b>	<b>10</b>	<b>11</b>	<b>12</b>	<b>13</b>	<b>14</b>	<b>15</b>	<b>16</b>
-----------------------	----------	----------	----------	----------	----------	----------	----------	----------	----------	-----------	-----------	-----------	-----------	-----------	-----------	-----------









Hillsborough County

Timing Sheet

4/19/2012 8:46:20 AM

Station : 1362 - Pendola Point Rd & US 41 (F006) ( Standard File )

Phase [1.1.1]

	1 (NL)	2 (ST)	3 (ET)	4 (WT)	5 (SL)	6 (NT)	7	8	9	10	11	12	13	14	15	16
Walk		7	9			7										
Ped Clearance		18	38			26										
Min Green	5	15	6	6	5	15										
Passage	6	8	6	6	6	8										
Max1	15	95	15	15	15	95										
Max2																
Yellow	5.1	5.1	3	4.3	5.1	5.1	9	9	9	9	9	9	9	9	9	9
Red	2.4	2.4	5.1	2.8	2.4	2.4										
Red Revert	3	3	3	3	3	3	3	3	3	3	3	3	3	3	3	3
Added Initial																
Max Initial																
Time Before Reduce	10	15	10	10	10	15										
Cars Before Reduce																
Time To Reduce	10	15	10	10	10	15										
Reduce By																
Min Gap	3	4	3	3	3	5										
Dynamic Max Limit																
Dynamic Max Step																
Auto Exit		ON				ON										
Rest In Walk																

Phase Option [1.1.2]

	1 (NL)	2 (ST)	3 (ET)	4 (WT)	5 (SL)	6 (NT)	7	8	9	10	11	12	13	14	15	16
Enable	ON	ON	ON	ON	ON	ON										
Auto Entry				ON												
Non Act1																
Non Act2																
Lock Call																
Min Recall		ON				ON										
Max Recall																
Ped Recall																
Soft Recall																
Dual Entry		ON				ON										
Sim Gap Enable	ON	ON			ON	ON										
Guar Passage																
Cond Service																
Add Init Calc																

Alternate Phase Program 1, Calls and Redirection [1.1.6.3]

Entry	Call Phases	From	To	From	To	From	To	From	To	Assigned Ph
1										
2										
3										
4										
5										
6										
7										
8										

Alternate Phase Program 2, Calls and Redirection [1.1.6.3]

Entry	Call Phases	From	To	From	To	From	To	From	To	Assigned Ph
1										
2										
3										
4										
5										
6										
7										
8										

Alternate Phase Program 1, Interval Times [1.1.6.1]

Phase	Walk	Ped Clear	Min Green	Passage	Max1	Max2	Yellow	Red Clear	Assign Ph	Bike Clear
1										
2										
3										
4										
5										
6										
7										
8										

Alternate Phase Program 2, Interval Times [1.1.6.1]

Phase	Walk	Ped Clear	Min Green	Passage	Max1	Max2	Yellow	Red Clear	Assign Ph	Bike Clear
1										
2										
3										
4										
5										
6										
7										
8										

Prepared By

Date Implemented

Reviewed By

Traffic Engineer





Hillsborough County

Timing Sheet

4/19/2012 8:46:20 AM

Station : 1362 - Pendola Point Rd & US 41 (F006) ( Standard File )

**Detector Alternate Program 1, Vehicle Parameters [5.5.1]**

	1	2	3	4	5	6	7	8	9	10	11	12	13	14	15	16
Call Phase																
Switch Phase																
Delay Time																

**Channels/SDLC, Assign to Phases [1.3.1]**

	1	2	3	4	5	6	7	8	9	10	11	12	13	14	15	16	17	18	19	20	21	22	23	24
PH/OLP #	1	2	3	4	5	6						4	2		6			3						
Type	VEH	VEH	VEH	VEH	VEH	VEH	VEH	VEH	OLP	OLP	OLP	OLP	PED	PED	PED	PED	OTH	PED	OTH	OTH	OTH	OTH	OTH	OTH
Flash	RED	YEL	RED	RED	RED	YEL	RED	RED	RED	RED	RED	RED	DRK	DRK	DRK	DRK	DRK	DRK	DRK	DRK	DRK	DRK	DRK	DRK
Flash 1-2 Hertz																								
Dimming Green																								
Dimming Yellow																								
Dimming Red																								
Alt Cyc	+	+	+	+	+	+	+	+	+	+	+	+	+	+	+	+	+	+	+	+	+	+	+	+

**Channel/SDLC, Parameters [1.3.3]**

TOD Dim Enable	Extra Maps Enable	D Connector Enable	Single BIU Map	IO Mode	Preempt or Ext Output
OFF	DEFAULT	TX2_V14	ON	AUTO	EXT

**Channel/SDLC, MMU Map [1.3.5]**

**MMU-to-Controller Channel Map**

1	2	3	4	5	6	7	8	9	10	11	12	13	14	15	16
1	2	3	4	5	6	7	8	9	10	11	12	13	14	15	16

**Channel/SDLC, Permissive [1.3.4]**

Channel	16	15	14	13	12	11	10	9	8	7	6	5	4	3	2
1															
2															
3															
4															
5															
6															
7															
8															
9															
10															
11															
12															
13															
14															
15															

**Channel/SDLC, Permissive [1.3.7]**

SDLC Device	Term/Fac	Detector								MMU	Diag
		1	2	3	4	5	6	7	8		
BIU#											
Present											
Peer to Peer											



















Hillsborough County

Timing Sheet

4/19/2012 8:48:15 AM

Station : 1372 - Port Sutton Rd & US 41 (F004) ( Standard File )

Phase [1.1.1]

	1 (NL)	2 (ST)	3	4	5 (SL)	6 (NT)	7	8 (ET)	9	10	11	12	13	14	15	16
Walk		7		8				7								
Ped Clearance		21		34				37								
Min Green	5	15		7	5	15		7								
Passage	3	8			3	8		6								
Max1	15	95		42	15	95		20								
Max2																
Yellow	5.1	5.1	9	4.3	5.1	5.1	9	4.3	9	9	9	9	9	9	9	9
Red	1.9	1.6		3.4	1.3	1.6		3.4								
Red Revert	3	3	3	3	3	3	3	3	3	3	3	3	3	3	3	3
Added Initial																
Max Initial																
Time Before Reduce		15				15		10								
Cars Before Reduce																
Time To Reduce		15				15		10								
Reduce By																
Min Gap		5				5		3								
Dynamic Max Limit																
Dynamic Max Step																
Auto Exit		ON				ON										
Rest In Walk																

Phase Option [1.1.2]

	1 (NL)	2 (ST)	3	4	5 (SL)	6 (NT)	7	8 (ET)	9	10	11	12	13	14	15	16
Enable	ON	ON		ON	ON	ON		ON								
Auto Entry				ON				ON								
Non Act1																
Non Act2																
Lock Call																
Min Recall		ON				ON										
Max Recall																
Ped Recall																
Soft Recall																
Dual Entry		ON		ON		ON		ON								
Sim Gap Enable	ON	ON			ON	ON		ON								
Guar Passage																
Cond Service																
Add Init Calc																

Alternate Phase Program 1, Calls and Redirection [1.1.6.3]

Entry	Call Phases	From	To	From	To	From	To	From	To	Assigned Ph
1										
2										
3										
4										
5										
6										
7										
8										

Alternate Phase Program 2, Calls and Redirection [1.1.6.3]

Entry	Call Phases	From	To	From	To	From	To	From	To	Assigned Ph
1										
2										
3										
4										
5										
6										
7										
8										

Alternate Phase Program 1, Interval Times [1.1.6.1]

Phase	Walk	Ped Clear	Min Green	Passage	Max1	Max2	Yellow	Red Clear	Assign Ph	Bike Clear
1										
2										
3										
4										
5										
6										
7										
8										

Alternate Phase Program 2, Interval Times [1.1.6.1]

Phase	Walk	Ped Clear	Min Green	Passage	Max1	Max2	Yellow	Red Clear	Assign Ph	Bike Clear
1										
2										
3										
4										
5										
6										
7										
8										

Prepared By

Date Implemented

Reviewed By

Traffic Engineer























Hillsborough County

Timing Sheet

4/19/2012 8:43:52 AM

Station : 1307 - Causeway Blvd & US 41 (G003) ( Standard File )

Phase [1.1.1]

	1 (NL)	2 (ST)	3 (EL)	4 (WT)	5 (SL)	6 (NT)	7 (WL)	8 (ET)	9	10	11	12	13	14	15	16
Walk		7		7		7		7								
Ped Clearance		34		29		36		27								
Min Green	5	15	5	7	5	15	5	7								
Passage	6	8	6	8	6	8	6	8								
Max1	30	40	15	25	20	40	15	25								
Max2																
Yellow	4.7	4.7	4.3	4.3	4.7	4.7	4.3	4.3	9	9	9	9	9	9	9	9
Red	3.1	3.1	3.3	3.3	3.1	3.1	3.3	3.3								
Red Revert	3	3	3	3	3	3	3	3	3	3	3	3	3	3	3	3
Added Initial																
Max Initial																
Time Before Reduce	10	15	10	15	10	15	10	15								
Cars Before Reduce																
Time To Reduce	10	15	10	15	10	15	10	15								
Reduce By																
Min Gap	4	4	3	4	3	4	3	4								
Dynamic Max Limit																
Dynamic Max Step																
Auto Exit		ON				ON										
Rest In Walk																

Phase Option [1.1.2]

	1 (NL)	2 (ST)	3 (EL)	4 (WT)	5 (SL)	6 (NT)	7 (WL)	8 (ET)	9	10	11	12	13	14	15	16
Enable	ON	ON	ON	ON	ON	ON	ON	ON								
Auto Entry				ON				ON								
Non Act1																
Non Act2																
Lock Call																
Min Recall		ON				ON										
Max Recall																
Ped Recall																
Soft Recall																
Dual Entry		ON		ON		ON		ON								
Sim Gap Enable	ON	ON	ON	ON	ON	ON	ON	ON								
Guar Passage																
Cond Service																
Add Init Calc																

Alternate Phase Program 1, Calls and Redirection [1.1.6.3]

Entry	Call Phases	From	To	From	To	From	To	From	To	Assigned Ph
1										
2										
3										
4										
5										
6										
7										
8										

Alternate Phase Program 2, Calls and Redirection [1.1.6.3]

Entry	Call Phases	From	To	From	To	From	To	From	To	Assigned Ph
1										
2										
3										
4										
5										
6										
7										
8										

Alternate Phase Program 1, Interval Times [1.1.6.1]

Phase	Walk	Ped Clear	Min Green	Passage	Max1	Max2	Yellow	Red Clear	Assign Ph	Bike Clear
1										
2										
3										
4										
5										
6										
7										
8										

Alternate Phase Program 2, Interval Times [1.1.6.1]

Phase	Walk	Ped Clear	Min Green	Passage	Max1	Max2	Yellow	Red Clear	Assign Ph	Bike Clear
1										
2										
3										
4										
5										
6										
7										
8										

Prepared By

Date Implemented

Reviewed By

Traffic Engineer

Hillsborough County

Timing Sheet

4/19/2012 8:43:52 AM

Station : 1307 - Causeway Blvd & US 41 (G003) ( Standard File )

Unit Parameters [1.2.1]

Free Ring Sequence	1
Onit Yellow Enable	OFF
Yellow 3 Second Disable	OFF
Disable Init Ped	OFF
Start Red Time	OFF
Local Flash Start	OFF
Enable Run	ON
Max Seek Dwell Time	
Max Seek Track Time	
Max Cycle Time	
Cycle Fault Action	ALARM
TS2 Det Faults	ON
SDLC Retry Time	
Diamond Mode	4PH
Phase Mode	STD8
Feature Profile	
Tone Disable	OFF
Console Timeout	30
Red Revert	3
Backup Time	
Auto Ped Clear	ON
StartUp Flash	

Comm, General Comm Parameters [6.1]

Station ID	Master Station ID	Fallback time	Allow Pencil	Port	System-Up	Sys-Down	PC/Print	Aux 232
1307		900	OFF					

Port Parameters [6.2]

Comm	Mode	Baud	MsgTime	Duplex	Enable	DialTime	Modem	ModemTime	Tel#1	Tel#2
System Up(P-A)										
System Down(P-B)										
PC/Print(P-2)										

Overlap General Parameters [1.5.1]

Conflict Lock	Lock Inhibit	Program Card	Use Parent	Canadian Fast Flash
OFF	OFF	OFF	ON	OFF

Overlap Program Parameters [1.5.2.1]

Overlap	Included Phases				Modifer Phases				Type	Green	Yellow	Red
Overlap 1	1	8							NORMAL		3.5	1.5
Overlap 2									NORMAL		3.5	1.5
Overlap 3									NORMAL		3.5	1.5
Overlap 4									NORMAL		3.5	1.5
Overlap 5									NORMAL		3.5	1.5
Overlap 6									NORMAL		3.5	1.5
Overlap 7									NORMAL		3.5	1.5
Overlap 8									NORMAL		3.5	1.5

Overlap Conflict Parameters+ [1.5.2.2]

Overlap	Conflicting Phases				Conflicting Overlaps				Conflicting Peds					R-TURN	
Overlap 1									8					OFF	
Overlap 2														OFF	OFF
Overlap 3														OFF	OFF
Overlap 4														OFF	OFF
Overlap 5														OFF	OFF
Overlap 6														OFF	OFF
Overlap 7														OFF	OFF
Overlap 8														OFF	OFF

Detector, Vehicle Parameters 1-16 [5.1]

	1	2	3	4	5	6	7	8	9	10	11	12	13	14	15	16
	(WBR1)	(WBT1)	(WBT2)	(WBL1)	(WBL2)	(NBT1)	(NBT2)	(NBL1)	(NBL2)	(EBR1)	(EBR2)	(EBT1)	(EBT2)	(EBL1)	(EBL2)	
Call Phase	4	4	4	7	7	6	6	1	1	8	8	8	8	3	3	
Switch Phase																
Delay Time	10									10	10					

Detector, Vehicle Parameters 17-32 [5.1]

	17	18	19	20	21	22	23	24	25	26	27	28	29	30	31	32
Call Phase	4	7	6	1	8	3	2	5	4	2	2	5				
Switch Phase																
Delay Time								10								























# Appendix D

## Existing Year 2013 Level of Service

TWO-WAY STOP CONTROL SUMMARY

Analyst: AG  
 Agency/Co.: American  
 Date Performed: 06/17/2013  
 Analysis Time Period: AM Peak  
 Intersection: Kracker Avenue & US 41  
 Jurisdiction: FDOT D7  
 Units: U. S. Customary  
 Analysis Year: 2013  
 Project ID: US 41 PD&E Study  
 East/West Street: Kracker Ave  
 North/South Street: US 41  
 Intersection Orientation: NS

Study period (hrs): 0.25

		Vehicle Volumes and Adjustments					
Major Street:	Approach Movement	Northbound			Southbound		
		1	2	3	4	5	6
		L	T	R	L	T	R
Volume		5	1286	6	1	749	2
Peak-Hour Factor, PHF		0.95	0.95	0.95	0.95	0.95	0.95
Hourly Flow Rate, HFR		5	1353	6	1	788	2
Percent Heavy Vehicles		5	--	--	5	--	--
Median Type/Storage		Raised curb			/ 1		
RT Channelized?		Yes			Yes		
Lanes		1	2	1	1	2	1
Configuration		L	T	R	L	T	R
Upstream Signal?		No			No		

Minor Street:	Approach Movement	Westbound			Eastbound		
		7	8	9	10	11	12
		L	T	R	L	T	R
Volume		14	0	5	5	0	8
Peak Hour Factor, PHF		0.95	0.95	0.95	0.95	0.95	0.95
Hourly Flow Rate, HFR		14	0	5	5	0	8
Percent Heavy Vehicles		0	0	0	0	0	0
Percent Grade (%)		0			0		
Flared Approach: Exists?/Storage		/			/		
Lanes		0	1	1	0	1	1
Configuration		LT		R	LT		R

		Delay, Queue Length, and Level of Service					
Approach	Movement	NB	SB	Westbound		Eastbound	
		1	4	7	8	9	10 11 12
		L	L	LT	R	LT	R
v (vph)		5	1	14		5	5 8
C(m) (vph)		808	489	128		457	211 659
v/c		0.01	0.00	0.11		0.01	0.02 0.01
95% queue length		0.02	0.01	0.36		0.03	0.07 0.04
Control Delay		9.5	12.4	36.5		13.0	22.5 10.5
LOS		A	B	E		B	C B
Approach Delay					30.3		
Approach LOS					D	15.1 C	

TWO-WAY STOP CONTROL SUMMARY

Analyst: AG  
 Agency/Co.: American  
 Date Performed: 06/17/2013  
 Analysis Time Period: AM Peak  
 Intersection: Ohio Street & US 41  
 Jurisdiction: FDOT D7  
 Units: U. S. Customary  
 Analysis Year: 2013  
 Project ID: US 41 PD&E Study  
 East/West Street: Ohio St  
 North/South Street: US 41  
 Intersection Orientation: NS

Study period (hrs): 0.25

Vehicle Volumes and Adjustments

Major Street:	Approach Movement	Northbound			Southbound		
		1 L	2 T	3 R	4 L	5 T	6 R

Volume		1341	13	52	770	
Peak-Hour Factor, PHF		0.95	0.95	0.95	0.95	
Hourly Flow Rate, HFR		1411	13	54	810	
Percent Heavy Vehicles		--	--	5	--	--
Median Type/Storage		Raised curb			/ 1	
RT Channelized?						
Lanes		2	0		1	2
Configuration		T	TR		L	T
Upstream Signal?		No				No

Minor Street:	Approach Movement	Westbound			Eastbound		
		7 L	8 T	9 R	10 L	11 T	12 R

Volume		24	24			
Peak Hour Factor, PHF		0.95	0.95			
Hourly Flow Rate, HFR		25	25			
Percent Heavy Vehicles		16	16			
Percent Grade (%)		0			0	
Flared Approach: Exists?/Storage			No	/		/
Lanes		0	0			
Configuration		LR				

Delay, Queue Length, and Level of Service

Approach	NB	SB	Westbound			Eastbound		
			7	8	9	10	11	12

Movement	1	4	7	8	9	10	11	12
Lane Config		L		LR				
v (vph)		54	50					
C(m) (vph)		459	192					
v/c		0.12	0.26					
95% queue length		0.40	1.00					
Control Delay		13.9	30.2					
LOS		B	D					
Approach Delay			30.2					
Approach LOS			D					

## TWO-WAY STOP CONTROL SUMMARY

Analyst: AG  
 Agency/Co.: American  
 Date Performed: 06/17/2013  
 Analysis Time Period: AM Peak  
 Intersection: Florence St & US 41  
 Jurisdiction: FDOT D7  
 Units: U. S. Customary  
 Analysis Year: 2013  
 Project ID: US 41 PD&E Study  
 East/West Street: Florence St  
 North/South Street: US 41  
 Intersection Orientation: NS

Study period (hrs): 0.25

## Vehicle Volumes and Adjustments

Major Street:	Approach Movement	Northbound			Southbound		
		1 L	2 T	3 R	4 L	5 T	6 R

Volume	5	1473	0	2	783	14		
Peak-Hour Factor, PHF	0.95	0.95	0.95	0.95	0.95	0.95		
Hourly Flow Rate, HFR	5	1550	0	2	824	14		
Percent Heavy Vehicles	5	--	--	5	--	--		
Median Type/Storage	Raised curb			/ 1				
RT Channelized?								
Lanes		1	2	0		1	2	0
Configuration		L	T	TR		L	T	TR
Upstream Signal?		No				No		

Minor Street:	Approach Movement	Westbound			Eastbound		
		7 L	8 T	9 R	10 L	11 T	12 R

Volume	5	0	10	10	0	6	
Peak Hour Factor, PHF	0.95	0.95	0.95	0.95	0.95	0.95	
Hourly Flow Rate, HFR	5	0	10	10	0	6	
Percent Heavy Vehicles	0	0	0	0	0	0	
Percent Grade (%)		0			0		
Flared Approach: Exists?/Storage			No	/		No	/
Lanes		0	1	0	0	1	0
Configuration		LTR				LTR	

## Delay, Queue Length, and Level of Service

Approach	NB	SB	Westbound			Eastbound		
			7	8	9	10	11	12

Movement	1	4						
Lane Config	L	L		LTR			LTR	
v (vph)	5	2		15			16	
C(m) (vph)	773	410		199			252	
v/c	0.01	0.00		0.08			0.06	
95% queue length	0.02	0.01		0.24			0.20	
Control Delay	9.7	13.8		24.6			20.3	
LOS	A	B		C			C	
Approach Delay				24.6			20.3	
Approach LOS				C			C	

HCM Signalized Intersection Capacity Analysis  
 35: Symmes Rd & US 41

7/22/2013



Movement	EBL	EBT	EBR	WBL	WBT	WBR	NBL	NBT	NBR	SBL	SBT	SBR
Lane Configurations		↕		↙	↘			↕	↙	↘	↕	
Volume (vph)	1	0	0	121	0	284	11	1287	139	127	743	0
Ideal Flow (vphpl)	1900	1900	1900	1900	1900	1900	1900	1900	1900	1900	1900	1900
Total Lost time (s)		7.2		7.2	7.2			6.2	6.2	7.0	6.2	
Lane Util. Factor		1.00		1.00	1.00			0.95	1.00	1.00	0.95	
Fr't		1.00		1.00	0.85			1.00	0.85	1.00	1.00	
Flt Protected		0.95		0.95	1.00			1.00	1.00	0.95	1.00	
Satd. Flow (prot)		1805		1703	1524			3437	1538	1719	3438	
Flt Permitted		0.37		0.76	1.00			0.95	1.00	0.07	1.00	
Satd. Flow (perm)		702		1357	1524			3250	1538	126	3438	
Peak-hour factor, PHF	0.95	0.95	0.95	0.95	0.95	0.95	0.95	0.95	0.95	0.95	0.95	0.95
Adj. Flow (vph)	1	0	0	127	0	299	12	1355	146	134	782	0
RTOR Reduction (vph)	0	0	0	0	0	0	0	0	59	0	0	0
Lane Group Flow (vph)	0	1	0	127	299	0	0	1367	87	134	782	0
Heavy Vehicles (%)	0%	0%	0%	6%	6%	6%	5%	5%	5%	5%	5%	5%
Turn Type	Perm			Perm			Perm		Perm	pm+pt		
Protected Phases		8			4			6		5	2	
Permitted Phases	8			4			6		6	2		
Actuated Green, G (s)		26.0		26.0	26.0			50.6	50.6	69.8	69.8	
Effective Green, g (s)		26.0		26.0	26.0			50.6	50.6	69.8	69.8	
Actuated g/C Ratio		0.24		0.24	0.24			0.46	0.46	0.64	0.64	
Clearance Time (s)		7.2		7.2	7.2			6.2	6.2	7.0	6.2	
Vehicle Extension (s)		3.0		3.0	3.0			4.0	4.0	3.0	4.0	
Lane Grp Cap (vph)		167		323	363			1506	713	259	2198	
v/s Ratio Prot					c0.20					c0.06	0.23	
v/s Ratio Perm		0.00		0.09				c0.42	0.06	0.27		
v/c Ratio		0.01		0.39	0.82			0.91	0.12	0.52	0.36	
Uniform Delay, d1		31.7		35.0	39.4			27.1	16.7	19.9	9.2	
Progression Factor		1.00		1.00	1.00			1.00	1.00	1.00	1.00	
Incremental Delay, d2		0.0		0.8	14.0			8.4	0.1	1.7	0.1	
Delay (s)		31.8		35.8	53.4			35.5	16.8	21.7	9.3	
Level of Service		C		D	D			D	B	C	A	
Approach Delay (s)		31.8			48.2			33.7			11.1	
Approach LOS		C			D			C			B	

Intersection Summary	
HCM Average Control Delay	28.6 HCM Level of Service C
HCM Volume to Capacity ratio	0.83
Actuated Cycle Length (s)	109.2 Sum of lost time (s) 20.4
Intersection Capacity Utilization	90.4% ICU Level of Service E
Analysis Period (min)	15

c Critical Lane Group

HCM Signalized Intersection Capacity Analysis  
 46: Palm Ave. & US 41

7/22/2013



Movement	EBL	EBT	EBR	WBL	WBT	WBR	NBL	NBT	NBR	SBL	SBT	SBR
Lane Configurations		↕		↙	↘		↙	↕	↘	↙	↘	↙
Volume (vph)	27	0	12	2	0	16	3	1557	6	27	903	4
Ideal Flow (vphpl)	1900	1900	1900	1900	1900	1900	1900	1900	1900	1900	1900	1900
Total Lost time (s)		6.7		6.7	6.7		6.2	6.2	6.2	6.5	6.5	
Lane Util. Factor		1.00		1.00	1.00		1.00	0.95	1.00	1.00	0.95	
Flt		0.96		1.00	0.85		1.00	1.00	0.85	1.00	1.00	
Flt Protected		0.97		0.95	1.00		0.95	1.00	1.00	0.95	1.00	
Satd. Flow (prot)		1759		1805	1615		1719	3438	1538	1719	3436	
Flt Permitted		0.79		0.73	1.00		0.30	1.00	1.00	0.07	1.00	
Satd. Flow (perm)		1428		1388	1615		542	3438	1538	131	3436	
Peak-hour factor, PHF	0.95	0.95	0.95	0.95	0.95	0.95	0.95	0.95	0.95	0.95	0.95	0.95
Adj. Flow (vph)	28	0	13	2	0	17	3	1639	6	28	951	4
RTOR Reduction (vph)	0	0	0	0	0	0	0	0	2	0	0	0
Lane Group Flow (vph)	0	41	0	2	17	0	3	1639	4	28	955	0
Heavy Vehicles (%)	0%	0%	0%	0%	0%	0%	5%	5%	5%	5%	5%	5%
Turn Type	Perm			Perm			Perm		Perm	pm+pt		
Protected Phases		4			4			2		1	1	2
Permitted Phases	4			4			2		2	1	1	
Actuated Green, G (s)		8.4		8.4	8.4		60.1	60.1	60.1	73.0	79.5	
Effective Green, g (s)		8.4		8.4	8.4		60.1	60.1	60.1	73.0	79.5	
Actuated g/C Ratio		0.08		0.08	0.08		0.60	0.60	0.60	0.72	0.79	
Clearance Time (s)		6.7		6.7	6.7		6.2	6.2	6.2	6.5		
Vehicle Extension (s)		3.0		3.0	3.0		4.0	4.0	4.0	2.5		
Lane Grp Cap (vph)		119		116	135		323	2050	917	298	2710	
v/s Ratio Prot					0.01			c0.48		0.01	c0.28	
v/s Ratio Perm		c0.03		0.00			0.01		0.00	0.06		
v/c Ratio		0.34		0.02	0.13		0.01	0.80	0.00	0.09	0.35	
Uniform Delay, d1		43.6		42.4	42.8		8.3	15.7	8.2	9.3	3.1	
Progression Factor		1.00		1.00	1.00		1.00	1.00	1.00	1.00	1.00	
Incremental Delay, d2		1.7		0.1	0.4		0.0	2.4	0.0	0.1	0.1	
Delay (s)		45.3		42.5	43.2		8.3	18.1	8.2	9.4	3.2	
Level of Service		D		D	D		A	B	A	A	A	
Approach Delay (s)		45.3			43.1			18.1			3.4	
Approach LOS		D			D			B			A	

Intersection Summary			
HCM Average Control Delay	13.3	HCM Level of Service	B
HCM Volume to Capacity ratio	0.70		
Actuated Cycle Length (s)	100.8	Sum of lost time (s)	19.4
Intersection Capacity Utilization	62.7%	ICU Level of Service	B
Analysis Period (min)	15		

c Critical Lane Group

TWO-WAY STOP CONTROL SUMMARY

Analyst: AG  
 Agency/Co.: American  
 Date Performed: 06/17/2013  
 Analysis Time Period: AM Peak  
 Intersection: Nundy Ave & US 41  
 Jurisdiction: FDOT D7  
 Units: U. S. Customary  
 Analysis Year: 2013  
 Project ID: US 41 PD&E Study  
 East/West Street: Nundy Ave  
 North/South Street: US 41  
 Intersection Orientation: NS

Study period (hrs): 0.25

Vehicle Volumes and Adjustments

Major Street:	Approach Movement	Northbound			Southbound		
		1 L	2 T	3 R	4 L	5 T	6 R
Volume		11	1652	17	25	868	3
Peak-Hour Factor, PHF		0.95	0.95	0.95	0.95	0.95	0.95
Hourly Flow Rate, HFR		11	1738	17	26	913	3
Percent Heavy Vehicles		5	--	--	5	--	--
Median Type/Storage		Raised curb			/ 1		
RT Channelized?							
Lanes		1	2	0	1	2	0
Configuration		L	T	TR	L	T	TR
Upstream Signal?		No			Yes		

Minor Street:	Approach Movement	Westbound			Eastbound		
		7 L	8 T	9 R	10 L	11 T	12 R
Volume		41	0	63	2	3	8
Peak Hour Factor, PHF		0.95	0.95	0.95	0.95	0.95	0.95
Hourly Flow Rate, HFR		43	0	66	2	3	8
Percent Heavy Vehicles		10	10	10	0	0	0
Percent Grade (%)		0			0		
Flared Approach: Exists?/Storage		No			/ No /		
Lanes		0	1	0	0	1	0
Configuration		LTR			LTR		

Delay, Queue Length, and Level of Service

Approach	NB	SB	Westbound			Eastbound		
			7	8	9	10	11	12
Movement	1	4	7	8	9	10	11	12
Lane Config	L	L		LTR			LTR	
v (vph)	11	26		109			13	
C(m) (vph)	830	340		129			216	
v/c	0.01	0.08		0.84			0.06	
95% queue length	0.04	0.25		5.26			0.19	
Control Delay	9.4	16.5		106.8			22.7	
LOS	A	C		F			C	
Approach Delay				106.8			22.7	
Approach LOS				F			C	

# HCM Signalized Intersection Capacity Analysis

40: Alice Ave & US 41

7/22/2013



Movement	EBL	EBT	EBR	WBL	WBT	WBP	NBL	NBT	NBR	SBL	SBT	SBR
Lane Configurations		↕		↖	↗	↗	↖	↕	↖	↖	↕	↖
Volume (vph)	14	25	6	213	42	329	10	1405	196	190	709	14
Ideal Flow (vphpl)	1900	1900	1900	1900	1900	1900	1900	1900	1900	1900	1900	1900
Total Lost time (s)		9.0		9.0	9.0	6.7	6.1	6.1	6.1	6.7	6.1	
Lane Util. Factor		1.00		1.00	1.00	1.00	1.00	0.95	1.00	1.00	0.95	
Fr <sub>t</sub>		0.98		1.00	1.00	0.85	1.00	1.00	0.85	1.00	1.00	
Fl <sub>t</sub> Protected		0.98		0.95	1.00	1.00	0.95	1.00	1.00	0.95	1.00	
Satd. Flow (prot)		1838		1703	1792	1524	1719	3438	1538	1719	3428	
Fl <sub>t</sub> Permitted		0.92		0.73	1.00	1.00	0.36	1.00	1.00	0.07	1.00	
Satd. Flow (perm)		1719		1302	1792	1524	657	3438	1538	122	3428	
Peak-hour factor, PHF	0.95	0.95	0.95	0.95	0.95	0.95	0.95	0.95	0.95	0.95	0.95	0.95
Adj. Flow (vph)	15	26	6	224	44	346	11	1479	206	200	746	15
RTOR Reduction (vph)	0	0	0	0	0	0	0	0	57	0	0	0
Lane Group Flow (vph)	0	47	0	224	44	346	11	1479	149	200	761	0
Heavy Vehicles (%)	0%	0%	0%	6%	6%	6%	5%	5%	5%	5%	5%	5%
Turn Type	Perm			Perm		pm+ov	Perm		Perm		pm+pt	
Protected Phases		8			4	5		6		5	2	
Permitted Phases	8			4		4	6		6		2	
Actuated Green, G (s)		43.0		43.0	43.0	50.3	52.7	52.7	52.7	66.7	66.7	
Effective Green, g (s)		43.0		43.0	43.0	50.3	52.7	52.7	52.7	66.7	66.7	
Actuated g/C Ratio		0.34		0.34	0.34	0.40	0.42	0.42	0.42	0.53	0.53	
Clearance Time (s)		9.0		9.0	9.0	6.7	6.1	6.1	6.1	6.7	6.1	
Vehicle Extension (s)		3.0		6.0	6.0	3.0	8.0	8.0	8.0	3.0	8.0	
Lane Grp Cap (vph)		592		449	617	614	277	1452	649	159	1832	
v/s Ratio Prot					0.02	c0.03		0.43		c0.07	0.22	
v/s Ratio Perm		0.03		0.17		0.19	0.02		0.10	c0.60		
v/c Ratio		0.08		0.50	0.07	0.56	0.04	1.02	0.23	1.26	0.42	
Uniform Delay, d1		27.6		32.4	27.5	28.8	21.2	36.0	23.1	35.5	17.4	
Progression Factor		1.00		1.00	1.00	1.00	1.00	1.00	1.00	1.00	1.00	
Incremental Delay, d2		0.3		3.9	0.2	3.7	0.3	28.4	0.8	156.9	0.7	
Delay (s)		27.8		36.3	27.7	32.5	21.5	64.4	23.9	192.4	18.1	
Level of Service		C		D	C	C	C	E	C	F	B	
Approach Delay (s)		27.8			33.5			59.2			54.4	
Approach LOS		C			C			E			D	

## Intersection Summary

HCM Average Control Delay	52.6	HCM Level of Service	D
HCM Volume to Capacity ratio	0.93		
Actuated Cycle Length (s)	124.8	Sum of lost time (s)	13.4
Intersection Capacity Utilization	86.0%	ICU Level of Service	E
Analysis Period (min)	15		

c Critical Lane Group



# HCM Signalized Intersection Capacity Analysis

## 9: Industrial Access Rd & US 41

7/22/2013



Movement	EBL	EBT	EBR	WBL	WBT	WBR	NBL	NBT	NBR	SBL	SBT	SBR
Lane Configurations		↖	↗		↖	↗	↘	↕	↗	↘	↕	↗
Volume (vph)	7	11	16	167	19	114	52	1434	154	16	813	28
Ideal Flow (vphpl)	1900	1900	1900	1900	1900	1900	1900	1900	1900	1900	1900	1900
Total Lost time (s)		6.3	6.3		6.3	6.3	6.4	6.4	6.4	6.4	6.4	6.4
Lane Util. Factor		1.00	1.00		1.00	1.00	1.00	0.95	1.00	1.00	0.95	1.00
Friction		1.00	0.85		1.00	0.85	1.00	1.00	0.85	1.00	1.00	0.85
Fit Protected		0.98	1.00		0.96	1.00	0.95	1.00	1.00	0.95	1.00	1.00
Satd. Flow (prot)		1637	1417		1715	1524	1719	3438	1538	1719	3438	1538
Fit Permitted		0.89	1.00		0.73	1.00	0.30	1.00	1.00	0.10	1.00	1.00
Satd. Flow (perm)		1479	1417		1316	1524	543	3438	1538	185	3438	1538
Peak-hour factor, PHF	0.95	0.95	0.95	0.95	0.95	0.95	0.95	0.95	0.95	0.95	0.95	0.95
Adj. Flow (vph)	7	12	17	176	20	120	55	1509	162	17	856	29
RTOR Reduction (vph)	0	0	13	0	0	19	0	0	66	0	0	12
Lane Group Flow (vph)	0	19	4	0	196	101	55	1509	96	17	856	17
Heavy Vehicles (%)	14%	14%	14%	6%	6%	6%	5%	5%	5%	5%	5%	5%
Turn Type	Perm		Perm	Perm		Perm	Perm		Perm	Perm		Perm
Protected Phases		4			4			2			2	
Permitted Phases	4		4	4		4	2		2	2		2
Actuated Green, G (s)		19.6	19.6		19.6	19.6	47.2	47.2	47.2	47.2	47.2	47.2
Effective Green, g (s)		19.6	19.6		19.6	19.6	47.2	47.2	47.2	47.2	47.2	47.2
Actuated g/C Ratio		0.25	0.25		0.25	0.25	0.59	0.59	0.59	0.59	0.59	0.59
Clearance Time (s)		6.3	6.3		6.3	6.3	6.4	6.4	6.4	6.4	6.4	6.4
Vehicle Extension (s)		6.0	6.0		6.0	6.0	8.0	8.0	8.0	8.0	8.0	8.0
Lane Grp Cap (vph)		365	349		324	376	322	2041	913	110	2041	913
v/s Ratio Prot								c0.44			0.25	
v/s Ratio Perm		0.01	0.00		c0.15	0.07	0.10		0.06	0.09		0.01
v/c Ratio		0.05	0.01		0.60	0.27	0.17	0.74	0.11	0.15	0.42	0.02
Uniform Delay, d1		22.9	22.6		26.5	24.2	7.3	11.7	7.0	7.2	8.7	6.6
Progression Factor		1.00	1.00		1.00	1.00	1.00	1.00	1.00	1.00	1.00	1.00
Incremental Delay, d2		0.2	0.0		5.6	1.1	1.1	2.5	0.2	3.0	0.6	0.0
Delay (s)		23.0	22.7		32.1	25.3	8.5	14.1	7.2	10.2	9.4	6.7
Level of Service		C	C		C	C	A	B	A	B	A	A
Approach Delay (s)		22.9			29.5			13.3			9.3	
Approach LOS		C			C			B			A	

Intersection Summary	
HCM Average Control Delay	13.9
HCM Volume to Capacity ratio	0.70
Actuated Cycle Length (s)	79.5
Intersection Capacity Utilization	70.7%
Analysis Period (min)	15
HCM Level of Service	B
Sum of lost time (s)	12.7
ICU Level of Service	C

c Critical Lane Group

# HCM Signalized Intersection Capacity Analysis

## 10: Pendola Point Rd & US 41

7/22/2013



Movement	EBL	EBT	EBR	WBL	WBT	WBR	NBL	NBT	NBR	SBL	SBT	SBR
Lane Configurations	↖	↗			↖	↗	↖	↗	↗	↖	↗	↗
Volume (vph)	43	8	17	66	16	456	11	1484	46	272	718	50
Ideal Flow (vphpl)	1900	1900	1900	1900	1900	1900	1900	1900	1900	1900	1900	1900
Total Lost time (s)	8.1	8.1			7.1	7.1	7.5	7.5	7.1	7.5	7.5	8.1
Lane Util. Factor	1.00	1.00			1.00	0.88	1.00	0.95	1.00	0.97	0.95	1.00
Frt	1.00	0.90			1.00	0.85	1.00	1.00	0.85	1.00	1.00	0.85
Flt Protected	0.95	1.00			0.96	1.00	0.95	1.00	1.00	0.95	1.00	1.00
Satd. Flow (prot)	1157	1091			1661	2584	1719	3438	1538	3335	3438	1538
Flt Permitted	0.95	1.00			0.96	1.00	0.95	1.00	1.00	0.95	1.00	1.00
Satd. Flow (perm)	1157	1091			1661	2584	1719	3438	1538	3335	3438	1538
Peak-hour factor, PHF	0.95	0.95	0.95	0.95	0.95	0.95	0.95	0.95	0.95	0.95	0.95	0.95
Adj. Flow (vph)	45	8	18	69	17	480	12	1562	48	286	756	53
RTOR Reduction (vph)	0	0	0	0	0	0	0	0	7	0	0	19
Lane Group Flow (vph)	45	26	0	0	86	480	12	1562	41	286	756	34
Heavy Vehicles (%)	56%	56%	56%	10%	10%	10%	5%	5%	5%	5%	5%	5%
Turn Type	Split			Split		Prot	Prot		pm+ov	Prot		pm+ov
Protected Phases	3	3		4	4	4	1	6	4	5	2	3
Permitted Phases								6				2
Actuated Green, G (s)	14.9	14.9			31.9	31.9	2.2	84.2	116.1	14.5	96.5	111.4
Effective Green, g (s)	14.9	14.9			31.9	31.9	2.2	84.2	116.1	14.5	96.5	111.4
Actuated g/C Ratio	0.08	0.08			0.18	0.18	0.01	0.48	0.66	0.08	0.55	0.63
Clearance Time (s)	8.1	8.1			7.1	7.1	7.5	7.5	7.1	7.5	7.5	8.1
Vehicle Extension (s)	6.0	6.0			6.0	6.0	6.0	8.0	6.0	6.0	8.0	6.0
Lane Grp Cap (vph)	98	93			302	469	22	1648	1016	275	1888	975
v/s Ratio Prot	c0.04	0.02			0.05	c0.19	0.01	c0.45	0.01	c0.09	0.22	0.00
v/s Ratio Perm									0.02			0.02
v/c Ratio	0.46	0.28			0.28	1.02	0.55	0.95	0.04	1.04	0.40	0.03
Uniform Delay, d1	76.6	75.4			62.1	71.9	86.3	43.7	10.4	80.6	22.9	12.0
Progression Factor	1.00	1.00			1.00	1.00	1.00	1.00	1.00	1.00	1.00	1.00
Incremental Delay, d2	9.3	4.6			1.5	47.6	50.7	12.8	0.0	65.1	0.6	0.0
Delay (s)	85.9	80.0			63.5	119.5	136.9	56.5	10.4	145.7	23.5	12.1
Level of Service	F	E			E	F	F	E	B	F	C	B
Approach Delay (s)		83.7			111.0			55.7			54.9	
Approach LOS		F			F			E			D	

### Intersection Summary

HCM Average Control Delay	65.4	HCM Level of Service	E
HCM Volume to Capacity ratio	0.92		
Actuated Cycle Length (s)	175.7	Sum of lost time (s)	30.2
Intersection Capacity Utilization	80.9%	ICU Level of Service	D
Analysis Period (min)	15		

c Critical Lane Group

HCM Signalized Intersection Capacity Analysis  
 17: Port Sutton Rd & US 41

7/22/2013



Movement	EBL	EBR	NBL	NBT	SBU	SBT	SBR
Lane Configurations							
Volume (vph)	31	11	21	1850	6	976	69
Ideal Flow (vphpl)	1900	1900	1900	1900	1900	1900	1900
Total Lost time (s)	7.7	7.0	7.0	6.7	6.4	6.7	7.7
Lane Util. Factor	1.00	1.00	1.00	0.95	1.00	0.95	1.00
Fr <sub>t</sub>	1.00	0.85	1.00	1.00	1.00	1.00	0.85
Fl <sub>t</sub> Protected	0.95	1.00	0.95	1.00	0.95	1.00	1.00
Satd. Flow (prot)	1271	1137	1719	3438	1719	3438	1538
Fl <sub>t</sub> Permitted	0.95	1.00	0.25	1.00	0.07	1.00	1.00
Satd. Flow (perm)	1271	1137	446	3438	128	3438	1538
Peak-hour factor, PHF	0.95	0.95	0.95	0.95	0.95	0.95	0.95
Adj. Flow (vph)	33	12	22	1947	6	1027	73
RTOR Reduction (vph)	0	11	0	0	0	0	13
Lane Group Flow (vph)	33	1	22	1947	6	1027	60
Heavy Vehicles (%)	42%	42%	5%	5%	5%	5%	5%
Turn Type		pm+ov	pm+pt		pm+pt		pm+ov
Protected Phases	8	1	1	6	5	2	8
Permitted Phases		8	6		2		2
Actuated Green, G (s)	11.7	15.1	104.5	101.1	99.3	98.2	109.9
Effective Green, g (s)	11.7	15.1	104.5	101.1	99.3	98.2	109.9
Actuated g/C Ratio	0.09	0.11	0.78	0.75	0.74	0.73	0.82
Clearance Time (s)	7.7	7.0	7.0	6.7	6.4	6.7	7.7
Vehicle Extension (s)	6.0	3.0	3.0	8.0	3.0	8.0	6.0
Lane Grp Cap (vph)	110	127	378	2580	107	2506	1255
v/s Ratio Prot	c0.03	0.00	c0.00	c0.57	0.00	0.30	0.00
v/s Ratio Perm		0.00	0.04		0.04		0.03
v/c Ratio	0.30	0.01	0.06	0.75	0.06	0.41	0.05
Uniform Delay, d1	57.7	53.2	4.0	9.7	9.3	7.1	2.4
Progression Factor	1.00	1.00	1.00	1.00	1.00	1.00	1.00
Incremental Delay, d2	4.3	0.0	0.1	2.1	0.2	0.5	0.0
Delay (s)	62.0	53.2	4.0	11.8	9.5	7.6	2.4
Level of Service	E	D	A	B	A	A	A
Approach Delay (s)	59.6			11.7		7.2	
Approach LOS	E			B		A	

**Intersection Summary**

HCM Average Control Delay	10.8	HCM Level of Service	B
HCM Volume to Capacity ratio	0.71		
Actuated Cycle Length (s)	134.7	Sum of lost time (s)	21.4
Intersection Capacity Utilization	69.0%	ICU Level of Service	C
Analysis Period (min)	15		

c Critical Lane Group

## TWO-WAY STOP CONTROL SUMMARY

Analyst: AG  
 Agency/Co.: American  
 Date Performed: 06/17/2013  
 Analysis Time Period: AM Peak  
 Intersection: Hartford St & US 41  
 Jurisdiction: FDOT D7  
 Units: U. S. Customary  
 Analysis Year: 2013  
 Project ID: US 41 PD&E Study  
 East/West Street: Hartford St  
 North/South Street: US 41  
 Intersection Orientation: NS

Study period (hrs): 0.25

## Vehicle Volumes and Adjustments

Major Street:	Approach Movement	Northbound			Southbound		
		1 L	2 T	3 R	4 L	5 T	6 R
Volume		8	1243	15	60	728	19
Peak-Hour Factor, PHF		0.95	0.95	0.95	0.95	0.95	0.95
Hourly Flow Rate, HFR		8	1308	15	63	766	20
Percent Heavy Vehicles		5	--	--	5	--	--
Median Type/Storage		Raised curb			/ 1		
RT Channelized?							
Lanes		1	2	0	1	2	0
Configuration		L	T	TR	L	T	TR
Upstream Signal?		No			No		

Minor Street:	Approach Movement	Westbound			Eastbound		
		7 L	8 T	9 R	10 L	11 T	12 R
Volume		13	0	67	3	0	2
Peak Hour Factor, PHF		0.95	0.95	0.95	0.95	0.95	0.95
Hourly Flow Rate, HFR		13	0	70	3	0	2
Percent Heavy Vehicles		27	27	27	0	0	0
Percent Grade (%)		0			0		
Flared Approach: Exists?/Storage		No			/ No /		
Lanes		0	1	0	0	1	0
Configuration		LTR			LTR		

## Delay, Queue Length, and Level of Service

Approach	NB	SB	Westbound			Eastbound		
			7	8	9	10	11	12
Movement	1	4						
Lane Config	L	L		LTR			LTR	
v (vph)	8	63		83			5	
C(m) (vph)	809	502		270			216	
v/c	0.01	0.13		0.31			0.02	
95% queue length	0.03	0.43		1.26			0.07	
Control Delay	9.5	13.2		24.1			22.1	
LOS	A	B		C			C	
Approach Delay				24.1			22.1	
Approach LOS				C			C	

Arterial Level of Service: NB US 41

Cross Street	Arterial Class	Flow Speed	Running Time	Signal Delay	Travel Time (s)	Dist (mi)	Arterial Speed	Arterial LOS
Symmes Rd	I	55	134.1	39.3	173.4	2.03	42.1	A
Palm Ave.	I	42	40.6	20.2	60.8	0.42	25.0	D
Gibsonton Dr	I	50	42.1	64.3	106.4	0.59	19.8	E
Riverview Dr	I	50	74.5	15.5	90.0	1.03	41.4	B
CR 676A (Madison Ave)	I	55	181.6	62.0	243.6	2.77	41.0	B
Port Sutton Rd	I	50	32.5	10.3	42.8	0.36	30.1	C
CR 676	I	50	83.3	49.9	133.2	1.16	31.3	C
Total	I		588.7	261.5	850.2	8.36	35.4	B

Arterial Level of Service: SB US 41

Cross Street	Arterial Class	Flow Speed	Running Time	Signal Delay	Travel Time (s)	Dist (mi)	Arterial Speed	Arterial LOS
Causeway Blvd	I	50	20.0	38.9	58.9	0.20	12.2	F
Port Sutton Rd	I	50	83.3	7.7	91.0	1.16	45.7	A
Pendola Point Rd	I	50	32.5	22.9	55.4	0.36	23.2	D
Industrial Access Rd	I	55	181.6	10.3	191.9	2.77	52.0	A
Alice Ave	I	50	74.5	18.3	92.8	1.03	40.1	B
Palm Ave.	I	50	42.1	3.7	45.8	0.59	46.0	A
Symmes Rd	I	50	36.3	10.7	47.0	0.42	32.4	C
Total	I		470.3	112.5	582.8	6.53	40.3	B

## TWO-WAY STOP CONTROL SUMMARY

Analyst: AG  
 Agency/Co.: American  
 Date Performed: 06/17/2013  
 Analysis Time Period: PM Peak  
 Intersection: Kracker Avenue & US 41  
 Jurisdiction: FDOT D7  
 Units: U. S. Customary  
 Analysis Year: 2013  
 Project ID: US 41 PD&E Study  
 East/West Street: Kracker Ave  
 North/South Street: US 41  
 Intersection Orientation: NS

Study period (hrs): 0.25

## Vehicle Volumes and Adjustments

Major Street:	Approach Movement	Northbound			Southbound		
		1 L	2 T	3 R	4 L	5 T	6 R

Volume	5	707	7	4	1347	3
Peak-Hour Factor, PHF	0.95	0.95	0.95	0.95	0.95	0.95
Hourly Flow Rate, HFR	5	744	7	4	1417	3
Percent Heavy Vehicles	5	--	--	5	--	--
Median Type/Storage	Raised curb			/ 1		
RT Channelized?	Yes			Yes		
Lanes	1	2	1	1	2	1
Configuration	L	T	R	L	T	R
Upstream Signal?	No			No		

Minor Street:	Approach Movement	Westbound			Eastbound		
		7 L	8 T	9 R	10 L	11 T	12 R

Volume	8	1	8	4	0	4
Peak Hour Factor, PHF	0.95	0.95	0.95	0.95	0.95	0.95
Hourly Flow Rate, HFR	8	1	8	4	0	4
Percent Heavy Vehicles	15	15	15	0	0	0
Percent Grade (%)	0		0			
Flared Approach: Exists?/Storage	/			/		
Lanes	0	1	1	0	1	1
Configuration	LT		R	LT		R

## Delay, Queue Length, and Level of Service

Approach Movement	NB	SB	Westbound			Eastbound		
	1 L	4 L	7 LT	8 R	9 R	10 LT	11 R	12 R
v (vph)	5	4	9	8	4	4	4	
C(m) (vph)	462	840	180	634	119	438		
v/c	0.01	0.00	0.05	0.01	0.03	0.01		
95% queue length	0.03	0.01	0.16	0.04	0.10	0.03		
Control Delay	12.9	9.3	26.1	10.8	36.3	13.3		
LOS	B	A	D	B	E	B		
Approach Delay	18.9			24.8				
Approach LOS	C			C				

## TWO-WAY STOP CONTROL SUMMARY

Analyst: AG  
 Agency/Co.: American  
 Date Performed: 06/17/2013  
 Analysis Time Period: PM Peak  
 Intersection: Ohio Street & US 41  
 Jurisdiction: FDOT D7  
 Units: U. S. Customary  
 Analysis Year: 2013  
 Project ID: US 41 PD&E Study  
 East/West Street: Ohio St  
 North/South Street: US 41  
 Intersection Orientation: NS

Study period (hrs): 0.25

## Vehicle Volumes and Adjustments

Major Street:	Approach Movement	Northbound			Southbound		
		1 L	2 T	3 R	4 L	5 T	6 R

Volume		741	11		74	1404	
Peak-Hour Factor, PHF		0.95	0.95		0.95	0.95	
Hourly Flow Rate, HFR		780	11		77	1477	
Percent Heavy Vehicles		--	--		5	--	--
Median Type/Storage		Raised curb			/ 1		
RT Channelized?							
Lanes		2	0		1	2	
Configuration		T	TR		L	T	
Upstream Signal?		No				No	

Minor Street:	Approach Movement	Westbound			Eastbound		
		7 L	8 T	9 R	10 L	11 T	12 R

Volume		14		25			
Peak Hour Factor, PHF		0.95		0.95			
Hourly Flow Rate, HFR		14		26			
Percent Heavy Vehicles		0		0			
Percent Grade (%)			0			0	
Flared Approach: Exists?/Storage				No	/		/
Lanes		0		0			
Configuration			LR				

## Delay, Queue Length, and Level of Service

Approach Movement	NB	SB	Westbound			Eastbound		
	1	4	7	8	9	10	11	12

Lane Config		L		LR				
v (vph)		77		40				
C(m) (vph)		806		370				
v/c		0.10		0.11				
95% queue length		0.32		0.36				
Control Delay		9.9		15.9				
LOS		A		C				
Approach Delay				15.9				
Approach LOS				C				

## TWO-WAY STOP CONTROL SUMMARY

Analyst: AG  
 Agency/Co.: American  
 Date Performed: 06/17/2013  
 Analysis Time Period: PM Peak  
 Intersection: Florence St & US 41  
 Jurisdiction: FDOT D7  
 Units: U. S. Customary  
 Analysis Year: 2013  
 Project ID: US 41 PD&E Study  
 East/West Street: Florence St  
 North/South Street: US 41  
 Intersection Orientation: NS

Study period (hrs): 0.25

## Vehicle Volumes and Adjustments

Major Street:	Approach Movement	Northbound			Southbound		
		1 L	2 T	3 R	4 L	5 T	6 R
Volume		9	812	1	4	1420	13
Peak-Hour Factor, PHF		0.95	0.95	0.95	0.95	0.95	0.95
Hourly Flow Rate, HFR		9	854	1	4	1494	13
Percent Heavy Vehicles		5	--	--	5	--	--
Median Type/Storage		Raised curb			/ 1		
RT Channelized?							
Lanes		1	2	0	1	2	0
Configuration		L	T	TR	L	T	TR
Upstream Signal?		No			No		

Minor Street:	Approach Movement	Westbound			Eastbound		
		7 L	8 T	9 R	10 L	11 T	12 R
Volume		3	0	8	13	0	5
Peak Hour Factor, PHF		0.95	0.95	0.95	0.95	0.95	0.95
Hourly Flow Rate, HFR		3	0	8	13	0	5
Percent Heavy Vehicles		0	0	0	0	0	0
Percent Grade (%)		0			0		
Flared Approach: Exists?/Storage		No			/ No /		
Lanes		0	1	0	0	1	0
Configuration		LTR			LTR		

## Delay, Queue Length, and Level of Service

Approach Movement	NB	SB	Westbound			Eastbound			
	1	4	7	8	9	10	11	12	
Lane Config	L	L	LTR			LTR			
v (vph)	9	4	11			18			
C(m) (vph)	426	762	376			131			
v/c	0.02	0.01	0.03			0.14			
95% queue length	0.06	0.02	0.09			0.46			
Control Delay	13.6	9.7	14.9			36.8			
LOS	B	A	B			E			
Approach Delay				14.9			36.8		
Approach LOS				B			E		



HCM Signalized Intersection Capacity Analysis  
 35: Symmes Rd & US 41

7/22/2013



Movement	EBL	EBT	EBR	WBL	WBT	WBR	NBL	NBT	NBR	SBL	SBT	SSR
Lane Configurations		↕		↖	↗			↕	↗	↖	↕	
Volume (vph)	0	2	0	84	0	95	2	711	86	322	1240	3
Ideal Flow (vphpl)	1900	1900	1900	1900	1900	1900	1900	1900	1900	1900	1900	1900
Total Lost time (s)		7.2		7.2	7.2			6.2	6.2	7.0	6.2	
Lane Util. Factor		1.00		1.00	1.00			0.95	1.00	1.00	0.95	
Fr't		1.00		1.00	0.85			1.00	0.85	1.00	1.00	
Flt Protected		1.00		0.95	1.00			1.00	1.00	0.95	1.00	
Satd. Flow (prot)		1900		1736	1553			3438	1538	1719	3437	
Flt Permitted		1.00		0.76	1.00			0.95	1.00	0.20	1.00	
Satd. Flow (perm)		1900		1382	1553			3269	1538	358	3437	
Peak-hour factor, PHF	0.95	0.95	0.95	0.95	0.95	0.95	0.95	0.95	0.95	0.95	0.95	0.95
Adj. Flow (vph)	0	2	0	88	0	100	2	748	91	339	1305	3
RTOR Reduction (vph)	0	0	0	0	0	0	0	0	61	0	0	0
Lane Group Flow (vph)	0	2	0	88	100	0	0	750	30	339	1308	0
Heavy Vehicles (%)	0%	0%	0%	4%	4%	4%	5%	5%	5%	5%	5%	5%
Turn Type	Perm			Perm			Perm		Perm	pm+pt		
Protected Phases		8			4			6		5	2	
Permitted Phases	8			4			6		6	2		
Actuated Green, G (s)		10.3		10.3	10.3			22.6	22.6	44.6	44.6	
Effective Green, g (s)		10.3		10.3	10.3			22.6	22.6	44.6	44.6	
Actuated g/C Ratio		0.15		0.15	0.15			0.33	0.33	0.65	0.65	
Clearance Time (s)		7.2		7.2	7.2			6.2	6.2	7.0	6.2	
Vehicle Extension (s)		3.0		3.0	3.0			4.0	4.0	3.0	4.0	
Lane Grp Cap (vph)		287		208	234			1082	509	533	2244	
v/s Ratio Prot		0.00			c0.06					0.14	c0.38	
v/s Ratio Perm				0.06				0.23	0.02	c0.28		
v/c Ratio		0.01		0.42	0.43			0.69	0.06	0.64	0.58	
Uniform Delay, d1		24.7		26.3	26.3			19.8	15.6	7.9	6.6	
Progression Factor		1.00		1.00	1.00			1.00	1.00	1.00	1.00	
Incremental Delay, d2		0.0		1.4	1.3			2.1	0.1	2.5	0.5	
Delay (s)		24.7		27.7	27.6			21.9	15.7	10.4	7.1	
Level of Service		C		C	C			C	B	B	A	
Approach Delay (s)		24.7			27.6			21.3			7.8	
Approach LOS		C			C			C			A	

Intersection Summary	
HCM Average Control Delay	13.4
HCM Volume to Capacity ratio	0.58
Actuated Cycle Length (s)	68.3
Intersection Capacity Utilization	81.7%
Analysis Period (min)	15
HCM Level of Service	B
Sum of lost time (s)	13.4
ICU Level of Service	D

c Critical Lane Group

# HCM Signalized Intersection Capacity Analysis

46: Palm Ave. & US 41

7/22/2013



Movement	EBL	EBT	EBR	WBL	WBT	WBR	NBL	NBT	NBR	SBL	SBT	SBR
Lane Configurations		↕		↙	↘		↙	↕	↘	↙	↕	↘
Volume (vph)	21	2	3	12	1	17	4	857	9	43	1620	17
Ideal Flow (vphpl)	1900	1900	1900	1900	1900	1900	1900	1900	1900	1900	1900	1900
Total Lost time (s)		6.7		6.7	6.7		6.2	6.2	6.2	6.5	6.5	
Lane Util. Factor		1.00		1.00	1.00		1.00	0.95	1.00	1.00	0.95	
Frt		0.98		1.00	0.86		1.00	1.00	0.85	1.00	1.00	
Flt Protected		0.96		0.95	1.00		0.95	1.00	1.00	0.95	1.00	
Satd. Flow (prot)		1729		1805	1630		1719	3438	1538	1719	3433	
Flt Permitted		0.75		0.74	1.00		0.14	1.00	1.00	0.26	1.00	
Satd. Flow (perm)		1354		1405	1630		250	3438	1538	469	3433	
Peak-hour factor, PHF	0.95	0.95	0.95	0.95	0.95	0.95	0.95	0.95	0.95	0.95	0.95	0.95
Adj. Flow (vph)	22	2	3	13	1	18	4	902	9	45	1705	18
RTOR Reduction (vph)	0	0	0	0	0	0	0	0	0	0	0	0
Lane Group Flow (vph)	0	27	0	13	19	0	4	902	5	45	1723	0
Heavy Vehicles (%)	4%	4%	4%	0%	0%	0%	5%	5%	5%	5%	5%	5%
Turn Type	Perm			Perm			Perm		Perm	pm+pt		
Protected Phases		4			4			2		1	12	
Permitted Phases	4			4			2		2	12		
Actuated Green, G (s)		7.8		7.8	7.8		50.2	50.2	50.2	65.4	71.9	
Effective Green, g (s)		7.8		7.8	7.8		50.2	50.2	50.2	65.4	71.9	
Actuated g/C Ratio		0.08		0.08	0.08		0.54	0.54	0.54	0.71	0.78	
Clearance Time (s)		6.7		6.7	6.7		6.2	6.2	6.2	6.5		
Vehicle Extension (s)		3.0		3.0	3.0		4.0	4.0	4.0	2.5		
Lane Grp Cap (vph)		114		118	137		136	1864	834	536	2666	
v/s Ratio Prot					0.01			0.26		0.01	c0.50	
v/s Ratio Perm		c0.02		0.01			0.02		0.00	0.05		
v/c Ratio		0.24		0.11	0.14		0.03	0.48	0.01	0.08	0.65	
Uniform Delay, d1		39.6		39.2	39.3		9.9	13.2	9.7	4.6	4.6	
Progression Factor		1.00		1.00	1.00		1.00	1.00	1.00	1.00	1.00	
Incremental Delay, d2		1.1		0.4	0.5		0.1	0.3	0.0	0.0	0.5	
Delay (s)		40.7		39.6	39.8		10.0	13.4	9.7	4.6	5.1	
Level of Service		D		D	D		A	B	A	A	A	
Approach Delay (s)		40.7			39.7			13.4			5.1	
Approach LOS		D			D			B			A	

## Intersection Summary

HCM Average Control Delay	8.6	HCM Level of Service	A
HCM Volume to Capacity ratio	0.61		
Actuated Cycle Length (s)	92.6	Sum of lost time (s)	13.2
Intersection Capacity Utilization	64.4%	ICU Level of Service	C
Analysis Period (min)	15		

c Critical Lane Group

## TWO-WAY STOP CONTROL SUMMARY

Analyst: AG  
 Agency/Co.: American  
 Date Performed: 06/17/2013  
 Analysis Time Period: PM Peak  
 Intersection: Nundy Ave & US 41  
 Jurisdiction: FDOT D7  
 Units: U. S. Customary  
 Analysis Year: 2013  
 Project ID: US 41 PD&E Study  
 East/West Street: Nundy Ave  
 North/South Street: US 41  
 Intersection Orientation: NS

Study period (hrs): 0.25

## Vehicle Volumes and Adjustments

Major Street:	Approach Movement	Northbound			Southbound		
		1 L	2 T	3 R	4 L	5 T	6 R
Volume		10	873	51	44	1560	7
Peak-Hour Factor, PHF		0.95	0.95	0.95	0.95	0.95	0.95
Hourly Flow Rate, HFR		10	918	53	46	1642	7
Percent Heavy Vehicles		5	--	--	5	--	--
Median Type/Storage		Raised curb			/ 1		
RT Channelized?							
Lanes		1	2	0	1	2	0
Configuration		L	T	TR	L	T	TR
Upstream Signal?		No			Yes		

Minor Street:	Approach Movement	Westbound			Eastbound		
		7 L	8 T	9 R	10 L	11 T	12 R
Volume		52	2	28	4	0	11
Peak Hour Factor, PHF		0.95	0.95	0.95	0.95	0.95	0.95
Hourly Flow Rate, HFR		54	2	29	4	0	11
Percent Heavy Vehicles		3	3	3	0	0	0
Percent Grade (%)		0			0		
Flared Approach: Exists?/Storage		No			/ No /		
Lanes		0	1	0	0	1	0
Configuration		LTR			LTR		

## Delay, Queue Length, and Level of Service

Approach Movement	NB 1	SB 4	Westbound			Eastbound		
			7	8	9	10	11	12
Lane Config	L	L		LTR			LTR	
v (vph)	10	46		85			15	
C(m) (vph)	453	688		247			285	
v/c	0.02	0.07		0.34			0.05	
95% queue length	0.07	0.21		1.47			0.17	
Control Delay	13.1	10.6		27.0			18.3	
LOS	B	B		D			C	
Approach Delay				27.0			18.3	
Approach LOS				D			C	

HCM Signalized Intersection Capacity Analysis  
40: Alice Ave & US 41

7/22/2013



Movement	EBL	EBT	EBR	WBL	WBT	WBR	NBL	NBT	NBR	SBL	SBT	SBR
Lane Configurations		↕		↙	↑	↗	↙	↕	↗	↙	↗	
Volume (vph)	8	18	13	245	33	102	10	614	272	381	1245	13
Ideal Flow (vphpl)	1900	1900	1900	1900	1900	1900	1900	1900	1900	1900	1900	1900
Total Lost time (s)		9.0		9.0	9.0	6.7	6.1	6.1	6.1	6.7	6.1	
Lane Util. Factor		1.00		1.00	1.00	1.00	1.00	0.95	1.00	1.00	0.95	
Frt		0.95		1.00	1.00	0.85	1.00	1.00	0.85	1.00	1.00	
Flt Protected		0.99		0.95	1.00	1.00	0.95	1.00	1.00	0.95	1.00	
Satd. Flow (prot)		1693		1719	1810	1538	1719	3438	1538	1719	3433	
Flt Permitted		0.96		0.73	1.00	1.00	0.17	1.00	1.00	0.26	1.00	
Satd. Flow (perm)		1640		1322	1810	1538	300	3438	1538	463	3433	
Peak-hour factor, PHF	0.95	0.95	0.95	0.95	0.95	0.95	0.95	0.95	0.95	0.95	0.95	0.95
Adj. Flow (vph)	8	19	14	258	35	107	11	646	286	401	1311	14
RTOR Reduction (vph)	0	0	0	0	0	0	0	0	180	0	0	0
Lane Group Flow (vph)	0	41	0	258	35	107	11	646	106	401	1325	0
Heavy Vehicles (%)	6%	6%	6%	5%	5%	5%	5%	5%	5%	5%	5%	5%
Turn Type	Perm			Perm		pm+ov	Perm		Perm	pm+pt		
Protected Phases		8			4	5		6		5	2	
Permitted Phases	8			4		4	6		6		2	
Actuated Green, G (s)		43.0		43.0	43.0	58.0	45.0	45.0	45.0	66.7	66.7	
Effective Green, g (s)		43.0		43.0	43.0	58.0	45.0	45.0	45.0	66.7	66.7	
Actuated g/C Ratio		0.34		0.34	0.34	0.46	0.36	0.36	0.36	0.53	0.53	
Clearance Time (s)		9.0		9.0	9.0	6.7	6.1	6.1	6.1	6.7	6.1	
Vehicle Extension (s)		3.0		6.0	6.0	3.0	8.0	8.0	8.0	3.0	8.0	
Lane Grp Cap (vph)		565		455	624	715	108	1240	555	398	1835	
v/s Ratio Prot					0.02	0.02		0.19		c0.12	0.39	
v/s Ratio Perm		0.02		c0.20		0.05	0.04		0.07	c0.42		
v/c Ratio		0.07		0.57	0.06	0.15	0.10	0.52	0.19	1.01	0.72	
Uniform Delay, d1		27.5		33.3	27.3	19.2	26.5	31.4	27.4	23.8	22.0	
Progression Factor		1.00		1.00	1.00	1.00	1.00	1.00	1.00	1.00	1.00	
Incremental Delay, d2		0.2		5.1	0.2	0.4	1.9	1.6	0.8	47.0	2.5	
Delay (s)		27.7		38.4	27.5	19.7	28.4	33.0	28.2	70.9	24.5	
Level of Service		C		D	C	B	C	C	C	E	C	
Approach Delay (s)		27.7			32.4			31.5			35.3	
Approach LOS		C			C			C			D	

Intersection Summary

HCM Average Control Delay	33.7	HCM Level of Service	C
HCM Volume to Capacity ratio	0.81		
Actuated Cycle Length (s)	124.8	Sum of lost time (s)	15.7
Intersection Capacity Utilization	85.2%	ICU Level of Service	E
Analysis Period (min)	15		

c Critical Lane Group

HCM Signalized Intersection Capacity Analysis  
 9: Industrial Access Rd & US 41

7/22/2013



Movement	EBL	EBT	EBR	WBL	WBT	WBR	NBL	NBT	NBR	SBL	SBT	SBR
Lane Configurations		↖	↗		↖	↗	↖	↗	↗	↖	↗	↗
Volume (vph)	22	37	46	199	4	19	13	641	258	92	1440	10
Ideal Flow (vphpl)	1900	1900	1900	1900	1900	1900	1900	1900	1900	1900	1900	1900
Total Lost time (s)		6.3	6.3		6.3	6.3	6.4	6.4	6.4	6.4	6.4	6.4
Lane Util. Factor		1.00	1.00		1.00	1.00	1.00	0.95	1.00	1.00	0.95	1.00
Fr't		1.00	0.85		1.00	0.85	1.00	1.00	0.85	1.00	1.00	0.85
Flt Protected		0.98	1.00		0.95	1.00	0.95	1.00	1.00	0.95	1.00	1.00
Satd. Flow (prot)		1847	1599		1776	1583	1719	3438	1538	1719	3438	1538
Flt Permitted		0.84	1.00		0.68	1.00	0.10	1.00	1.00	0.38	1.00	1.00
Satd. Flow (perm)		1588	1599		1275	1583	179	3438	1538	688	3438	1538
Peak-hour factor, PHF	0.95	0.95	0.95	0.95	0.95	0.95	0.95	0.95	0.95	0.95	0.95	0.95
Adj. Flow (vph)	23	39	48	209	4	20	14	675	272	97	1516	11
RTOR Reduction (vph)	0	0	19	0	0	15	0	0	112	0	0	5
Lane Group Flow (vph)	0	62	29	0	213	5	14	675	160	97	1516	6
Heavy Vehicles (%)	1%	1%	1%	2%	2%	2%	5%	5%	5%	5%	5%	5%
Turn Type	Perm		Perm	Perm		Perm	Perm		Perm	Perm		Perm
Protected Phases		4			4			2			2	
Permitted Phases	4		4	4		4	2		2	2		2
Actuated Green, G (s)		20.6	20.6		20.6	20.6	47.8	47.8	47.8	47.8	47.8	47.8
Effective Green, g (s)		20.6	20.6		20.6	20.6	47.8	47.8	47.8	47.8	47.8	47.8
Actuated g/C Ratio		0.25	0.25		0.25	0.25	0.59	0.59	0.59	0.59	0.59	0.59
Clearance Time (s)		6.3	6.3		6.3	6.3	6.4	6.4	6.4	6.4	6.4	6.4
Vehicle Extension (s)		6.0	6.0		6.0	6.0	8.0	8.0	8.0	8.0	8.0	8.0
Lane Grp Cap (vph)		403	406		324	402	106	2026	906	406	2026	906
v/s Ratio Prot								0.20			c0.44	
v/s Ratio Perm		0.04	0.02		c0.17	0.00	0.08		0.10	0.14		0.00
v/c Ratio		0.15	0.07		0.66	0.01	0.13	0.33	0.18	0.24	0.75	0.01
Uniform Delay, d1		23.5	23.0		27.1	22.6	7.4	8.5	7.6	8.0	12.2	6.9
Progression Factor		1.00	1.00		1.00	1.00	1.00	1.00	1.00	1.00	1.00	1.00
Incremental Delay, d2		0.5	0.2		7.5	0.0	2.6	0.4	0.4	1.4	2.6	0.0
Delay (s)		24.0	23.2		34.6	22.7	10.0	9.0	8.1	9.3	14.8	6.9
Level of Service		C	C		C	C	A	A	A	A	B	A
Approach Delay (s)		23.6			33.6			8.7			14.4	
Approach LOS		C			C			A			B	

**Intersection Summary**

HCM Average Control Delay	14.4	HCM Level of Service	B
HCM Volume to Capacity ratio	0.72		
Actuated Cycle Length (s)	81.1	Sum of lost time (s)	12.7
Intersection Capacity Utilization	86.1%	ICU Level of Service	E
Analysis Period (min)	15		

c Critical Lane Group

HCM Signalized Intersection Capacity Analysis  
 10: Pendola Point Rd & US 41

7/22/2013



Movement	EBL	EBT	EBR	WBL	WBT	WBR	NBL	NBT	NBR	SBL	SBT	SBR
Lane Configurations	↖	↗			↖	↗	↖	↗	↖	↗	↖	↗
Volume (vph)	90	43	9	95	0	173	2	813	42	363	1503	4
Ideal Flow (vphpl)	1900	1900	1900	1900	1900	1900	1900	1900	1900	1900	1900	1900
Total Lost time (s)	8.1	8.1			7.1	7.1	7.5	7.5	7.1	7.5	7.5	8.1
Lane Util. Factor	1.00	1.00			1.00	0.88	1.00	0.95	1.00	0.97	0.95	1.00
Fr't	1.00	0.97			1.00	0.85	1.00	1.00	0.85	1.00	1.00	0.85
Flt Protected	0.95	1.00			0.95	1.00	0.95	1.00	1.00	0.95	1.00	1.00
Satd. Flow (prot)	1583	1625			1656	2608	1719	3438	1538	3335	3438	1538
Flt Permitted	0.95	1.00			0.95	1.00	0.95	1.00	1.00	0.95	1.00	1.00
Satd. Flow (perm)	1583	1625			1656	2608	1719	3438	1538	3335	3438	1538
Peak-hour factor, PHF	0.95	0.95	0.95	0.95	0.95	0.95	0.95	0.95	0.95	0.95	0.95	0.95
Adj Flow (vph)	95	45	9	100	0	182	2	856	44	382	1582	4
RTOR Reduction (vph)	0	0	0	0	0	0	0	0	17	0	0	1
Lane Group Flow (vph)	95	54	0	0	100	182	2	856	27	382	1582	3
Heavy Vehicles (%)	14%	14%	14%	9%	9%	9%	5%	5%	5%	5%	5%	5%
Turn Type	Split			Split		Prot	Prot		pm+ov	Prot		pm+ov
Protected Phases	3	3		4	4	4	1	6	4	5	2	3
Permitted Phases								6				2
Actuated Green, G (s)	15.7	15.7			15.2	15.2	1.4	48.7	63.9	21.0	68.3	84.0
Effective Green, g (s)	15.7	15.7			15.2	15.2	1.4	48.7	63.9	21.0	68.3	84.0
Actuated g/C Ratio	0.12	0.12			0.12	0.12	0.01	0.37	0.49	0.16	0.52	0.64
Clearance Time (s)	8.1	8.1			7.1	7.1	7.5	7.5	7.1	7.5	7.5	8.1
Vehicle Extension (s)	6.0	6.0			6.0	6.0	6.0	8.0	6.0	6.0	8.0	6.0
Lane Grp Cap (vph)	190	195			192	303	18	1280	751	535	1795	988
v/s Ratio Prot	c0.06	0.03			0.06	c0.07	0.00	0.25	0.00	c0.11	c0.46	0.00
v/s Ratio Perm									0.01			0.00
v/c Ratio	0.50	0.28			0.52	0.60	0.11	0.67	0.04	0.71	0.88	0.00
Uniform Delay, d1	53.9	52.4			54.4	54.9	64.1	34.3	17.4	52.1	27.7	8.4
Progression Factor	1.00	1.00			1.00	1.00	1.00	1.00	1.00	1.00	1.00	1.00
Incremental Delay, d2	5.7	2.2			6.3	5.9	7.6	2.8	0.1	6.4	6.6	0.0
Delay (s)	59.6	54.6			60.6	60.8	71.7	37.1	17.5	58.5	34.3	8.4
Level of Service	E	D			E	E	E	D	B	E	C	A
Approach Delay (s)		57.8			60.7			36.2			38.9	
Approach LOS		E			E			D			D	

**Intersection Summary**

HCM Average Control Delay	40.9	HCM Level of Service	D
HCM Volume to Capacity ratio	0.81		
Actuated Cycle Length (s)	130.8	Sum of lost time (s)	30.2
Intersection Capacity Utilization	76.6%	ICU Level of Service	D
Analysis Period (min)	15		

c Critical Lane Group

HCM Signalized Intersection Capacity Analysis  
 17: Port Sutton Rd & US 41

7/22/2013



Movement	EBL	EBR	NBL	NBT	SBU	SBT	SBR
Lane Configurations							
Volume (vph)	77	54	0	1040	1	1882	4
Ideal Flow (vphpl)	1900	1900	1900	1900	1900	1900	1900
Total Lost time (s)	7.7	7.0		6.7	6.4	6.7	7.7
Lane Util. Factor	1.00	1.00		0.95	1.00	0.95	1.00
Fr't	1.00	0.85		1.00	1.00	1.00	0.85
Flt Protected	0.95	1.00		1.00	0.95	1.00	1.00
Satd. Flow (prot)	1805	1615		3438	1719	3438	1538
Flt Permitted	0.95	1.00		1.00	0.24	1.00	1.00
Satd. Flow (perm)	1805	1615		3438	442	3438	1538
Peak-hour factor, PHF	0.95	0.95	0.95	0.95	0.95	0.95	0.95
Adj Flow (vph)	81	57	0	1095	1	1981	4
RTOR Reduction (vph)	0	6	0	0	0	0	1
Lane Group Flow (vph)	81	51	0	1095	1	1981	3
Heavy Vehicles (%)	0%	0%	5%	5%	5%	5%	5%
Turn Type		pm+ov	pm+pt		pm+pt		pm+ov
Protected Phases	8	1	1	6	5	2	8
Permitted Phases		8	6		2		2
Actuated Green, G (s)	14.2	18.7		103.0	100.1	99.0	113.2
Effective Green, g (s)	14.2	18.7		103.0	100.1	99.0	113.2
Actuated g/C Ratio	0.10	0.13		0.74	0.72	0.71	0.81
Clearance Time (s)	7.7	7.0		6.7	6.4	6.7	7.7
Vehicle Extension (s)	6.0	3.0		8.0	3.0	8.0	6.0
Lane Grp Cap (vph)	184	217		2546	328	2447	1252
v/s Ratio Prot	c0.04	c0.01		c0.32	0.00	c0.58	0.00
v/s Ratio Perm		0.02			0.00		0.00
v/c Ratio	0.44	0.23		0.43	0.00	0.81	0.00
Uniform Delay, d1	58.7	53.8		6.9	5.6	13.6	2.4
Progression Factor	1.00	1.00		1.00	1.00	1.00	1.00
Incremental Delay, d2	4.7	0.6		0.5	0.0	3.0	0.0
Delay (s)	63.4	54.4		7.4	5.6	16.7	2.4
Level of Service	E	D		A	A	B	A
Approach Delay (s)	59.7			7.4		16.6	
Approach LOS	E			A		B	

**Intersection Summary**

HCM Average Control Delay	15.3	HCM Level of Service	B
HCM Volume to Capacity ratio	0.79		
Actuated Cycle Length (s)	139.1	Sum of lost time (s)	28.1
Intersection Capacity Utilization	69.9%	ICU Level of Service	C
Analysis Period (min)	15		

c Critical Lane Group

## TWO-WAY STOP CONTROL SUMMARY

Analyst: AG  
 Agency/Co.: American  
 Date Performed: 06/17/2013  
 Analysis Time Period: PM Peak  
 Intersection: Hartford St & US 41  
 Jurisdiction: FDOT D7  
 Units: U. S. Customary  
 Analysis Year: 2013  
 Project ID: US 41 PD&E Study  
 East/West Street: Hartford St  
 North/South Street: US 41  
 Intersection Orientation: NS

Study period (hrs): 0.25

## Vehicle Volumes and Adjustments

Major Street: Approach Movement	Northbound			Southbound		
	1 L	2 T	3 R	4 L	5 T	6 R

Volume	7	1022	20	37	2066	2
Peak-Hour Factor, PHF	0.95	0.95	0.95	0.95	0.95	0.95
Hourly Flow Rate, HFR	7	1075	21	38	2174	2
Percent Heavy Vehicles	5	--	--	5	--	--
Median Type/Storage	Raised curb			/ 1		
RT Channelized?						
Lanes	1	2	0	1	2	0
Configuration	L	T	TR	L	T	TR
Upstream Signal?	No			No		

Minor Street: Approach Movement	Westbound			Eastbound		
	7 L	8 T	9 R	10 L	11 T	12 R

Volume	19	0	56	10	0	5
Peak Hour Factor, PHF	0.95	0.95	0.95	0.95	0.95	0.95
Hourly Flow Rate, HFR	20	0	58	10	0	5
Percent Heavy Vehicles	13	13	13	10	10	10
Percent Grade (%)	0			0		
Flared Approach: Exists?/Storage	No			/ No /		
Lanes	0	1	0	0	1	0
Configuration	LTR			LTR		

## Delay, Queue Length, and Level of Service

Approach Movement Lane Config	NB	SB	Westbound			Eastbound		
	1 L	4 L	7 L	8 LTR	9 L	10 L	11 LTR	12 L

v (vph)	7	38	78			15			
C(m) (vph)	231	615	233			44			
v/c	0.03	0.06	0.33			0.34			
95% queue length	0.09	0.20	1.41			1.17			
Control Delay	21.1	11.2	28.0			124.4			
LOS	C	B	D			F			
Approach Delay				28.0			124.4		
Approach LOS				D			F		



Arterial Level of Service: NB US 41

Cross Street	Arterial Class	Flow Speed	Running Time	Signal Delay	Travel Time (s)	Dist (mi)	Arterial Speed	Arterial LOS
Symmes Rd	I	55	134.1	24.0	158.1	2.03	46.2	A
Palm Ave.	I	42	40.6	13.9	54.5	0.42	27.9	C
Gibsonton Dr	I	50	42.1	33.3	75.4	0.59	28.0	C
Riverview Dr	I	50	74.5	9.7	84.2	1.03	44.2	A
CR 676A (Madison Ave)	I	55	181.6	41.2	222.8	2.77	44.8	A
Port Sutton Rd	I	50	32.5	6.5	39.0	0.36	33.0	C
CR 676	I	50	83.3	37.7	121.0	1.16	34.4	B
Total	I		588.7	166.3	755.0	8.36	39.9	B

Arterial Level of Service: SB US 41

Cross Street	Arterial Class	Flow Speed	Running Time	Signal Delay	Travel Time (s)	Dist (mi)	Arterial Speed	Arterial LOS
Causeway Blvd	I	50	20.0	38.6	58.6	0.20	12.3	F
Port Sutton Rd	I	50	83.3	17.9	101.2	1.16	41.1	B
Pendola Point Rd	I	50	32.5	30.0	62.5	0.36	20.6	E
Industrial Access Rd	I	55	181.6	16.1	197.7	2.77	50.5	A
Alice Ave	I	50	74.5	24.9	99.4	1.03	37.5	B
Palm Ave.	I	50	42.1	6.1	48.2	0.59	43.7	A
Symmes Rd	I	50	36.3	8.2	44.5	0.42	34.2	B
Total	I		470.3	141.8	612.1	6.53	38.4	B

# Appendix E

## Traffic Methodology Statement

## MEMORANDUM

**Date:** January 17, 2013  
**To:** Waddah Farah, Florida Department of Transportation (FDOT), District Seven  
**From:** Akram Hussein, PE, PTOE  
**Cc:** Rick Adair (FDOT PD&E Project Manager); Peter Maass PE, PTOE, David Winkle, Jeff Novotny, PE, AICP; Larry Weatherby, PE; David Bredahl, AICP, Arpita Guha, PE  
**Subject:** Traffic Methodology Statement for:  
**US 41 PD&E Study from Kracker Avenue to South of SR 676 (Causeway Boulevard) FPID: 430056-1-22-01**  
**American Project No: 5127041**

1. Traffic data collection including 72-hour vehicle classification counts, 72-hour bi-directional counts at intersection approaches and 4-hour turning movement counts at the study intersections will be conducted in January 2013 as shown below:
  - A. 72-hour vehicle classification counts (bi-directional approach volumes) at the following locations:
    - (1) US 41 between Kracker Avenue and Gibsonton Drive
    - (2) US 41 between Gibsonton Drive and CR 676A (Madison Avenue)
    - (3) US 41 between CR 676A (Madison Avenue) and south of CR 676 (Causeway Boulevard)
  - B. 72-hour machine counts (bi-directional approach volumes) and at the same time, perform 4-hour manual (2 hours AM and 2 hours PM) vehicle turning movement counts for peak hours at the following intersections:
    - (1) Kracker Avenue (unsignalized)
    - (2) Ohio Street (unsignalized)
    - (3) Florence Street (unsignalized)
    - (4) Symmes Road (signalized)
    - (5) Palm Avenue (signalized)
    - (6) Nundy Avenue (unsignalized)
    - (7) Gibsonton Drive (signalized)
    - (8) Riverview Drive (signalized)\*

- (9) CR 676A (Madison Avenue) – signalized\*
  - (10) Port Sutton Road (signalized)\*
  - (11) Hartford Street (unsignalized)
  - (12) CR 676 (Causeway Boulevard) – signalized
2. Intersections with \* provide a direct connection to Port of Tampa facilities. These approaches will be further evaluated for time periods that are outside the typical morning (7-9 a.m.) and afternoon (4-6 p.m.) peak periods. This evaluation would require reviewing the 72-hour traffic count data to identify alternative time periods that truck traffic may be prevalent and could possibly impact operations of the subject intersection. The sizing of turn lanes at these intersections will be performed in a manner that allows for the accommodation of high-volume truck movements made throughout an average day.
  3. The project will use the standard K factor of 9% for this area. Recommendations will be made for the D-factor and the truck percentages to be used for this study. A memorandum on the recommended design traffic factors will be submitted to FDOT for review and approval.
  4. Existing year 2013 design hour traffic volumes will be developed by applying the recommended K and D factors to the annual average daily traffic (AADT) on the intersection approaches to determine the directional design hour volumes (DDHV) and then distributing the DDHV in the proportion of the existing turning traffic at the intersections to derive the design hour volumes.
  5. K and D factors along with existing turning percentages will be used for the development of the existing and the future design hour volumes. The TURNS program will not be used.
  6. The Tampa Bay Regional Planning (TBRPM) Base year (2006) model will be checked for reasonableness and if necessary for accuracy, adjustments will be made as needed.
  7. The opening year will be 2020, the design year will be 2040 and the interim year will be 2030.
  8. 2035 model traffic projections will be extrapolated to derive 2040 AADTs.
  9. The opening (2020), interim (2030) and design year (2040) AADTs will be developed through interpolation/extrapolation in between the existing year (2013) AADT volumes and 2035 Build Model traffic volumes.
  10. Future design hour traffic volumes will be developed by applying the recommended K and D factors to the annual average daily traffic (AADT) on the intersection approaches to determine the directional design hour volumes (DDHV) and then distributing the DDHV in the proportion of the existing turning traffic at the intersections to derive the future design hour volumes.
  11. The traffic volumes will not be balanced exactly from one intersection departure to the next intersection approach. Reasonableness checks will be done based on access (driveways) and land uses that occur between intersections.

12. The future AADTs and therefore, the AM and PM design hour volumes for the no-build and the build conditions will be considered to be the same.
13. All existing and future traffic volumes will be reviewed and approved by FDOT.
14. AM and PM design hour volumes will both be developed to insure adequate lane geometry.
15. Existing, No-Build and Build intersection and roadway segment analysis will be conducted using SYNCHRO 7 and HCS+ Version 5.5. Output from SYNCHRO 7 will be using the HCM methodology.
16. Future analysis of No Build and Build conditions will be conducted for years 2020, 2030, and 2040.
17. Queue length analysis will be conducted for the design year 2040 AM and PM peak hours for build conditions.
18. Arterial analysis will be conducted using SYNCHRO 7 within the intersections shown in number 1. Arterial analysis will only include intersections within the study limits. Output from SYNCHRO 7 will be using the HCM methodology.
19. For the un-signalized locations, signal warrants 1 & 2 will be tested if that location needs to be signalized in the future to meet the acceptable LOS.
20. As the study area is urbanized, acceptable LOS will be considered to be "D" along the study corridor within the project limits based on the Planning Boundaries for LOS Standards for Hillsborough County and Table 8-1 of the 2009 FDOT Quality/Level of Service Handbook.

# Appendix F

## Design Year 2040 No-Build and Build Level of Service

## TWO-WAY STOP CONTROL SUMMARY

Analyst: AG  
 Agency/Co.: American  
 Date Performed: 06/17/2013  
 Analysis Time Period: AM Peak  
 Intersection: Kracker Avenue & US 41  
 Jurisdiction: FDOT D7  
 Units: U. S. Customary  
 Analysis Year: 2040 No Build  
 Project ID: US 41 PD&E Study  
 East/West Street: Kracker Ave  
 North/South Street: US 41  
 Intersection Orientation: NS Study period (hrs): 0.25

## Vehicle Volumes and Adjustments

Major Street:	Approach Movement	Northbound			Southbound		
		1 L	2 T	3 R	4 L	5 T	6 R

Volume	9	2433	11	2	1348	4
Peak-Hour Factor, PHF	0.95	0.95	0.95	0.95	0.95	0.95
Hourly Flow Rate, HFR	9	2561	11	2	1418	4
Percent Heavy Vehicles	5	--	--	5	--	--
Median Type/Storage	Raised curb			/ 1		
RT Channelized?	Yes			Yes		
Lanes	1	2	1	1	2	1
Configuration	L	T	R	L	T	R
Upstream Signal?	No			No		

Minor Street:	Approach Movement	Westbound			Eastbound		
		7 L	8 T	9 R	10 L	11 T	12 R

Volume	25	0	9	8	0	13
Peak Hour Factor, PHF	0.95	0.95	0.95	0.95	0.95	0.95
Hourly Flow Rate, HFR	26	0	9	8	0	13
Percent Heavy Vehicles	0	0	0	0	0	0
Percent Grade (%)	0		0			
Flared Approach: Exists?/Storage	/			/		
Lanes	0	1	1	0	1	1
Configuration	LT		R	LT		R

## Delay, Queue Length, and Level of Service

Approach	NB	SB	Westbound			Eastbound		
			7 LT	8 R	9 R	10 LT	11 R	12 R

v (vph)	9	2	26	9	8	13
C(m) (vph)	461	162	23	204	73	438
v/c	0.02	0.01	1.13	0.04	0.11	0.03
95% queue length	0.06	0.04	3.32	0.14	0.35	0.09
Control Delay	13.0	27.5	474.6	23.5	60.3	13.5
LOS	B	D	F	C	F	B
Approach Delay	358.6			31.3		
Approach LOS	F			D		

## TWO-WAY STOP CONTROL SUMMARY

Analyst: AG  
 Agency/Co.: American  
 Date Performed: 06/17/2013  
 Analysis Time Period: AM Peak  
 Intersection: Ohio Street & US 41  
 Jurisdiction: FDOT D7  
 Units: U. S. Customary  
 Analysis Year: 2040 No Build  
 Project ID: US 41 PD&E Study  
 East/West Street: Ohio St  
 North/South Street: US 41  
 Intersection Orientation: NS

Study period (hrs): 0.25

## Vehicle Volumes and Adjustments

Major Street:	Approach Movement	Northbound			Southbound		
		1 L	2 T	3 R	4 L	5 T	6 R

Volume		2412	23		79	1169	
Peak-Hour Factor, PHF		0.95	0.95		0.95	0.95	
Hourly Flow Rate, HFR		2538	24		83	1230	
Percent Heavy Vehicles		--	--		5	--	--
Median Type/Storage		Raised curb			/ 1		
RT Channelized?							
Lanes		2	0		1	2	
Configuration		T	TR		L	T	
Upstream Signal?		No			No		

Minor Street:	Approach Movement	Westbound			Eastbound		
		7 L	8 T	9 R	10 L	11 T	12 R

Volume		43		43			
Peak Hour Factor, PHF		0.95		0.95			
Hourly Flow Rate, HFR		45		45			
Percent Heavy Vehicles		16		16			
Percent Grade (%)			0			0	
Flared Approach: Exists?/Storage				No	/		/
Lanes		0		0			
Configuration			LR				

## Delay, Queue Length, and Level of Service

Approach	NB	SB	Westbound			Eastbound		
			7	8	9	10	11	12

Movement	1	4		7	8	9		10	11	12
Lane Config		L			LR					
v (vph)		83			90					
C(m) (vph)		162			48					
v/c		0.51			1.88					
95% queue length		2.51			9.00					
Control Delay		48.5			596.3					
LOS		E			F					
Approach Delay					596.3					
Approach LOS					F					



TWO-WAY STOP CONTROL SUMMARY

Analyst: AG  
 Agency/Co.: American  
 Date Performed: 06/17/2013  
 Analysis Time Period: AM Peak  
 Intersection: Florence St & US 41  
 Jurisdiction: FDOT D7  
 Units: U. S. Customary  
 Analysis Year: 2040 No Build  
 Project ID: US 41 PD&E Study  
 East/West Street: Florence St  
 North/South Street: US 41  
 Intersection Orientation: NS  
 Study period (hrs): 0.25

Vehicle Volumes and Adjustments

Major Street: Approach Movement	Northbound			Southbound		
	1 L	2 T	3 R	4 L	5 T	6 R

Volume	8	2236	0	4	1228	22
Peak-Hour Factor, PHF	0.95	0.95	0.95	0.95	0.95	0.95
Hourly Flow Rate, HFR	8	2353	0	4	1292	23
Percent Heavy Vehicles	5	--	--	5	--	--
Median Type/Storage	Raised curb			/ 1		
RT Channelized?						
Lanes	1	2	0	1	2	0
Configuration	L	T	TR	L	T	TR
Upstream Signal?	No			No		

Minor Street: Approach Movement	Westbound			Eastbound		
	7 L	8 T	9 R	10 L	11 T	12 R

Volume	9	0	17	17	0	11
Peak Hour Factor, PHF	0.95	0.95	0.95	0.95	0.95	0.95
Hourly Flow Rate, HFR	9	0	17	17	0	11
Percent Heavy Vehicles	0	0	0	0	0	0
Percent Grade (%)	0		0			
Flared Approach: Exists?/Storage	No		/		No /	
Lanes	0	1	0	0	1	0
Configuration	LTR			LTR		

Delay, Queue Length, and Level of Service

Approach Movement	NB	SB	Westbound			Eastbound		
	1	4	7	8	9	10	11	12

Lane Config	L	L	LTR			LTR		
v (vph)	8	4	26			28		
C(m) (vph)	506	196	72			125		
v/c	0.02	0.02	0.36			0.22		
95% queue length	0.05	0.06	1.37			0.81		
Control Delay	12.2	23.7	80.9			41.9		
LOS	B	C	F			E		
Approach Delay			80.9			41.9		
Approach LOS			F			E		

HCM Signalized Intersection Capacity Analysis  
 35: Symmes Rd & US 41

7/23/2013



Movement	EBL	EBT	EBR	WBL	WBT	WBR	NBL	NBT	NBR	SBL	SBT	SBR
Lane Configurations		↕		↙	↘			↕	↙	↘	↕	
Volume (vph)	1	0	0	311	0	728	17	2019	218	211	1236	0
Ideal Flow (vphpl)	1900	1900	1900	1900	1900	1900	1900	1900	1900	1900	1900	1900
Total Lost time (s)		7.2		7.2	7.2			6.2	6.2	7.0	6.2	
Lane Util. Factor		1.00		1.00	1.00			0.95	1.00	1.00	0.95	
Frt		1.00		1.00	0.85			1.00	0.85	1.00	1.00	
Flt Protected		0.95		0.95	1.00			1.00	1.00	0.95	1.00	
Satd. Flow (prot)		1805		1703	1524			3437	1538	1719	3438	
Flt Permitted		0.10		0.76	1.00			0.93	1.00	0.05	1.00	
Satd. Flow (perm)		182		1357	1524			3192	1538	82	3438	
Peak-hour factor, PHF	0.95	0.95	0.95	0.95	0.95	0.95	0.95	0.95	0.95	0.95	0.95	0.95
Adj. Flow (vph)	1	0	0	327	0	766	18	2125	229	222	1301	0
RTOR Reduction (vph)	0	0	0	0	0	0	0	0	54	0	0	0
Lane Group Flow (vph)	0	1	0	327	766	0	0	2143	175	222	1301	0
Heavy Vehicles (%)	0%	0%	0%	6%	6%	6%	5%	5%	5%	5%	5%	5%
Turn Type	Perm			Perm			Perm		Perm	pm+pt		
Protected Phases		8			4			6			5	2
Permitted Phases	8			4			6		6		2	
Actuated Green, G (s)		41.8		41.8	41.8			80.8	80.8	94.8	94.8	
Effective Green, g (s)		41.8		41.8	41.8			80.8	80.8	94.8	94.8	
Actuated g/C Ratio		0.28		0.28	0.28			0.54	0.54	0.63	0.63	
Clearance Time (s)		7.2		7.2	7.2			6.2	6.2	7.0	6.2	
Vehicle Extension (s)		3.0		3.0	3.0			4.0	4.0	3.0	4.0	
Lane Grp Cap (vph)		51		378	425			1719	828	128	2173	
v/s Ratio Prot					c0.50					c0.08	0.38	
v/s Ratio Perm		0.01		0.24				0.67	0.11	c1.01		
v/c Ratio		0.02		0.87	1.80			1.25	0.21	1.73	0.60	
Uniform Delay, d1		39.2		51.4	54.1			34.6	18.0	48.6	16.3	
Progression Factor		1.00		1.00	1.00			1.00	1.00	1.00	1.00	
Incremental Delay, d2		0.2		18.2	370.3			116.1	0.2	360.9	0.5	
Delay (s)		39.4		69.6	424.4			150.7	18.2	409.5	16.9	
Level of Service		D		E	F			F	B	F	B	
Approach Delay (s)		39.4			318.3			137.9			74.1	
Approach LOS		D			F			F			E	

Intersection Summary			
HCM Average Control Delay	157.9	HCM Level of Service	F
HCM Volume to Capacity ratio	1.71		
Actuated Cycle Length (s)	150.0	Sum of lost time (s)	14.2
Intersection Capacity Utilization	151.9%	ICU Level of Service	H
Analysis Period (min)	15		

c Critical Lane Group

HCM Signalized Intersection Capacity Analysis  
 46: Palm Ave. & US 41

7/23/2013



Movement	EBL	EBT	EBR	WBL	WBT	WBR	NBL	NBT	NBR	SBL	SBT	SBR
Lane Configurations		↕		↙	↘		↙	↕	↘	↙	↘	
Volume (vph)	49	0	22	4	0	29	5	2589	9	41	1391	7
Ideal Flow (vphpl)	1900	1900	1900	1900	1900	1900	1900	1900	1900	1900	1900	1900
Total Lost time (s)		6.7		6.7	6.7		6.2	6.2	6.2	6.5	6.5	
Lane Util. Factor		1.00		1.00	1.00		1.00	0.95	1.00	1.00	0.95	
Flt		0.96		1.00	0.85		1.00	1.00	0.85	1.00	1.00	
Flt Protected		0.97		0.95	1.00		0.95	1.00	1.00	0.95	1.00	
Satd. Flow (prot)		1760		1805	1615		1719	3438	1538	1719	3436	
Flt Permitted		0.77		0.76	1.00		0.18	1.00	1.00	0.05	1.00	
Satd. Flow (perm)		1409		1435	1615		323	3438	1538	88	3436	
Peak-hour factor, PHF	0.95	0.95	0.95	0.95	0.95	0.95	0.95	0.95	0.95	0.95	0.95	0.95
Adj. Flow (vph)	52	0	23	4	0	31	5	2725	9	43	1464	7
RTOR Reduction (vph)	0	0	0	0	0	0	0	0	2	0	0	0
Lane Group Flow (vph)	0	75	0	4	31	0	5	2725	7	43	1471	0
Heavy Vehicles (%)	0%	0%	0%	0%	0%	0%	5%	5%	5%	5%	5%	5%
Turn Type	Perm			Perm			Perm		Perm	pm+pt		
Protected Phases		4			4			2			1	1 2
Permitted Phases	4			4			2		2		1 2	
Actuated Green, G (s)		11.4		11.4	11.4		82.2	82.2	82.2	88.7	95.2	
Effective Green, g (s)		11.4		11.4	11.4		82.2	82.2	82.2	88.7	95.2	
Actuated g/C Ratio		0.10		0.10	0.10		0.69	0.69	0.69	0.74	0.80	
Clearance Time (s)		6.7		6.7	6.7		6.2	6.2	6.2	6.5		
Vehicle Extension (s)		3.0		3.0	3.0		4.0	4.0	4.0	2.5		
Lane Grp Cap (vph)		134		137	154		222	2365	1058	154	2737	
v/s Ratio Prot					0.02			c0.79		0.02	c0.43	
v/s Ratio Perm		c0.05		0.00			0.02		0.00	0.19		
v/c Ratio		0.56		0.03	0.20		0.02	1.15	0.01	0.28	0.54	
Uniform Delay, d1		51.7		49.0	49.9		5.9	18.6	5.8	30.3	4.3	
Progression Factor		1.00		1.00	1.00		1.00	1.00	1.00	1.00	1.00	
Incremental Delay, d2		5.0		0.1	0.6		0.1	73.8	0.0	0.7	0.2	
Delay (s)		56.6		49.1	50.5		6.0	92.5	5.9	31.0	4.5	
Level of Service		E		D	D		A	F	A	C	A	
Approach Delay (s)		56.6			50.3			92.1			5.2	
Approach LOS		E			D			F			A	

**Intersection Summary**

HCM Average Control Delay	61.0	HCM Level of Service	E
HCM Volume to Capacity ratio	1.07		
Actuated Cycle Length (s)	119.5	Sum of lost time (s)	19.4
Intersection Capacity Utilization	93.0%	ICU Level of Service	F
Analysis Period (min)	15		

c Critical Lane Group

TWO-WAY STOP CONTROL SUMMARY

Analyst: AG  
 Agency/Co.: American  
 Date Performed: 06/17/2013  
 Analysis Time Period: AM Peak  
 Intersection: Nundy Ave & US 41  
 Jurisdiction: FDOT D7  
 Units: U. S. Customary  
 Analysis Year: 2040 No Build  
 Project ID: US 41 PD&E Study  
 East/West Street: Nundy Ave  
 North/South Street: US 41  
 Intersection Orientation: NS Study period (hrs): 0.25

Vehicle Volumes and Adjustments

Major Street: Approach Movement	Northbound			Southbound		
	1	2	3	4	5	6
	L	T	R	L	T	R

Volume	16	2545	27	41	1407	5
Peak-Hour Factor, PHF	0.95	0.95	0.95	0.95	0.95	0.95
Hourly Flow Rate, HFR	16	2678	28	43	1481	5
Percent Heavy Vehicles	5	--	--	5	--	--
Median Type/Storage	Raised curb			/ 1		
RT Channelized?						
Lanes	1	2	0	1	2	0
Configuration	L	T	TR	L	T	TR
Upstream Signal?	No			Yes		

Minor Street: Approach Movement	Westbound			Eastbound		
	7	8	9	10	11	12
	L	T	R	L	T	R

Volume	75	0	115	3	6	14
Peak Hour Factor, PHF	0.95	0.95	0.95	0.95	0.95	0.95
Hourly Flow Rate, HFR	78	0	121	3	6	14
Percent Heavy Vehicles	10	10	10	0	0	0
Percent Grade (%)	0		0			
Flared Approach: Exists?/Storage			No	/	No /	
Lanes	0	1	0	0	1	0
Configuration	LTR			LTR		

Delay, Queue Length, and Level of Service

Approach Movement	NB	SB	Westbound			Eastbound		
	1	4	7	8	9	10	11	12
Lane Config	L	L	LTR			LTR		

v (vph)	16	43	199			23		
C(m) (vph)	612	141				0		
v/c	0.03	0.30						
95% queue length	0.08	1.20						
Control Delay	11.0	41.4						
LOS	B	E				F		
Approach Delay								
Approach LOS								

HCM Signalized Intersection Capacity Analysis  
 40: Alice Ave & US 41

7/23/2013



Movement	EBL	EBT	EBR	WBL	WBT	WBR	NBL	NBT	NBR	SBL	SBT	SBR
Lane Configurations		↕		↙	↘	↗	↖	↕	↗	↖	↕	↗
Volume (vph)	21	38	9	499	99	771	17	2281	318	358	1341	26
Ideal Flow (vphpl)	1900	1900	1900	1900	1900	1900	1900	1900	1900	1900	1900	1900
Total Lost time (s)		9.0		9.0	9.0	6.7	6.1	6.1	6.1	6.7	6.1	
Lane Util. Factor		1.00		1.00	1.00	1.00	1.00	0.95	1.00	1.00	0.95	
Flt		0.98		1.00	1.00	0.85	1.00	1.00	0.85	1.00	1.00	
Flt Protected		0.98		0.95	1.00	1.00	0.95	1.00	1.00	0.95	1.00	
Satd. Flow (prot)		1839		1703	1792	1524	1719	3438	1538	1719	3428	
Flt Permitted		0.88		0.74	1.00	1.00	0.17	1.00	1.00	0.04	1.00	
Satd. Flow (perm)		1652		1327	1792	1524	302	3438	1538	71	3428	
Peak-hour factor, PHF	0.95	0.95	0.95	0.95	0.95	0.95	0.95	0.95	0.95	0.95	0.95	0.95
Adj. Flow (vph)	22	40	9	525	104	812	18	2401	335	377	1412	27
RTOR Reduction (vph)	0	0	0	0	0	0	0	0	39	0	0	0
Lane Group Flow (vph)	0	71	0	525	104	812	18	2401	296	377	1439	0
Heavy Vehicles (%)	0%	0%	0%	6%	6%	6%	5%	5%	5%	5%	5%	5%
Turn Type	Perm			Perm		pm+ov	Perm		Perm		pm+pt	
Protected Phases		8			4	5		6			5	2
Permitted Phases	8			4		4	6		6		2	
Actuated Green, G (s)		43.0		43.0	43.0	63.3	94.9	94.9	94.9	121.9	121.9	
Effective Green, g (s)		43.0		43.0	43.0	63.3	94.9	94.9	94.9	121.9	121.9	
Actuated g/C Ratio		0.24		0.24	0.24	0.35	0.53	0.53	0.53	0.68	0.68	
Clearance Time (s)		9.0		9.0	9.0	6.7	6.1	6.1	6.1	6.7	6.1	
Vehicle Extension (s)		3.0		6.0	6.0	3.0	8.0	8.0	8.0	3.0	8.0	
Lane Grp Cap (vph)		395		317	428	536	159	1813	811	234	2322	
v/s Ratio Prot					0.06	0.17		0.70		c0.18	0.42	
v/s Ratio Perm		0.04		c0.40		0.36	0.06		0.19	c0.91		
v/c Ratio		0.18		1.66	0.24	1.51	0.11	1.32	0.36	1.61	0.62	
Uniform Delay, d1		54.5		68.5	55.3	58.4	21.4	42.5	24.9	67.8	16.2	
Progression Factor		1.00		1.00	1.00	1.00	1.00	1.00	1.00	1.00	1.00	
Incremental Delay, d2		1.0		309.0	1.3	241.2	1.4	149.9	1.3	294.0	1.3	
Delay (s)		55.5		377.5	56.7	299.6	22.8	192.4	26.2	361.7	17.4	
Level of Service		E		F	E	F	C	F	C	F	B	
Approach Delay (s)		55.5			310.4			171.1			88.9	
Approach LOS		E			F			F			F	

Intersection Summary			
HCM Average Control Delay	178.2	HCM Level of Service	F
HCM Volume to Capacity ratio	1.59		
Actuated Cycle Length (s)	180.0	Sum of lost time (s)	15.7
Intersection Capacity Utilization	135.4%	ICU Level of Service	H
Analysis Period (min)	15		

c Critical Lane Group

# HCM Signalized Intersection Capacity Analysis

## 9: Industrial Access Rd & US 41

7/23/2013



Movement	EBL	EBT	EBR	WBL	WBT	WBR	NBL	NBT	NBR	SBL	SBT	SBR
Lane Configurations		↖	↗		↖	↗	↘	↕	↗	↘	↕	↗
Volume (vph)	11	16	24	589	65	402	98	2714	291	28	1441	49
Ideal Flow (vphpl)	1900	1900	1900	1900	1900	1900	1900	1900	1900	1900	1900	1900
Total Lost time (s)		6.3	6.3		6.3	6.3	6.4	6.4	6.4	6.4	6.4	6.4
Lane Util. Factor		1.00	1.00		1.00	1.00	1.00	0.95	1.00	1.00	0.95	1.00
Frt		1.00	0.85		1.00	0.85	1.00	1.00	0.85	1.00	1.00	0.85
Flt Protected		0.98	1.00		0.96	1.00	0.95	1.00	1.00	0.95	1.00	1.00
Satd. Flow (prot)		1633	1417		1715	1524	1719	3438	1538	1719	3438	1538
Flt Permitted		0.46	1.00		0.73	1.00	0.08	1.00	1.00	0.05	1.00	1.00
Satd. Flow (perm)		768	1417		1302	1524	137	3438	1538	87	3438	1538
Peak-hour factor, PHF	0.95	0.95	0.95	0.95	0.95	0.95	0.95	0.95	0.95	0.95	0.95	0.95
Adj. Flow (vph)	12	17	25	620	68	423	103	2857	306	29	1517	52
RTOR Reduction (vph)	0	0	16	0	0	1	0	0	53	0	0	18
Lane Group Flow (vph)	0	29	9	0	688	422	103	2857	253	29	1517	34
Heavy Vehicles (%)	14%	14%	14%	6%	6%	6%	5%	5%	5%	5%	5%	5%
Turn Type	Perm		Perm	Perm		Perm	Perm		Perm	Perm		Perm
Protected Phases		4			4			2				2
Permitted Phases	4		4	4		4	2		2	2		2
Actuated Green, G (s)		53.7	53.7		53.7	53.7	83.6	83.6	83.6	83.6	83.6	83.6
Effective Green, g (s)		53.7	53.7		53.7	53.7	83.6	83.6	83.6	83.6	83.6	83.6
Actuated g/C Ratio		0.36	0.36		0.36	0.36	0.56	0.56	0.56	0.56	0.56	0.56
Clearance Time (s)		6.3	6.3		6.3	6.3	6.4	6.4	6.4	6.4	6.4	6.4
Vehicle Extension (s)		6.0	6.0		6.0	6.0	8.0	8.0	8.0	8.0	8.0	8.0
Lane Grp Cap (vph)		275	507		466	546	76	1916	857	48	1916	857
v/s Ratio Prot								c0.83				0.44
v/s Ratio Perm		0.04	0.01		c0.53	0.28	0.75		0.16	0.33		0.02
v/c Ratio		0.11	0.02		1.48	0.77	1.36	1.49	0.30	0.60	0.79	0.04
Uniform Delay, d1		32.1	31.1		48.1	42.8	33.2	33.2	17.6	22.2	26.3	15.0
Progression Factor		1.00	1.00		1.00	1.00	1.00	1.00	1.00	1.00	1.00	1.00
Incremental Delay, d2		0.5	0.0		225.7	8.5	224.3	223.8	0.9	45.6	3.4	0.1
Delay (s)		32.6	31.1		273.9	51.2	257.5	257.0	18.5	67.7	29.7	15.1
Level of Service		C	C		F	D	F	F	B	E	C	B
Approach Delay (s)		31.9			189.1			234.7			30.0	
Approach LOS		C			F			F			C	

Intersection Summary		
HCM Average Control Delay	170.2	HCM Level of Service F
HCM Volume to Capacity ratio	1.49	
Actuated Cycle Length (s)	150.0	Sum of lost time (s) 12.7
Intersection Capacity Utilization	134.7%	ICU Level of Service H
Analysis Period (min)	15	

c Critical Lane Group

HCM Signalized Intersection Capacity Analysis  
 10: Pendola Point Rd & US 41

7/23/2013



Movement	EBL	EBT	EBR	WBL	WBT	WBR	NBL	NBT	NBR	SBL	SBT	SBR
Lane Configurations	↖	↗			↖	↗	↖	↗	↗	↖	↗	↖
Volume (vph)	65	11	26	133	32	921	20	2628	82	485	1279	89
Ideal Flow (vphpl)	1900	1900	1900	1900	1900	1900	1900	1900	1900	1900	1900	1900
Total Lost time (s)	8.1	8.1			7.1	7.1	7.5	7.5	7.5	7.5	7.5	8.1
Lane Util. Factor	1.00	1.00			1.00	0.88	1.00	0.95	1.00	0.97	0.95	1.00
Fr <sub>t</sub>	1.00	0.90			1.00	0.85	1.00	1.00	0.85	1.00	1.00	0.85
Fl <sub>t</sub> Protected	0.95	1.00			0.96	1.00	0.95	1.00	1.00	0.95	1.00	1.00
Satd. Flow (prot)	1157	1091			1660	2584	1719	3438	1538	3335	3438	1538
Fl <sub>t</sub> Permitted	0.95	1.00			0.74	1.00	0.95	1.00	1.00	0.95	1.00	1.00
Satd. Flow (perm)	1157	1091			1280	2584	1719	3438	1538	3335	3438	1538
Peak-hour factor, PHF	0.95	0.95	0.95	0.95	0.95	0.95	0.95	0.95	0.95	0.95	0.95	0.95
Adj. Flow (vph)	68	12	27	140	34	969	21	2766	86	511	1346	94
RTOR Reduction (vph)	0	0	0	0	0	0	0	0	11	0	0	31
Lane Group Flow (vph)	68	39	0	0	174	969	21	2766	75	511	1346	63
Heavy Vehicles (%)	56%	56%	56%	10%	10%	10%	5%	5%	5%	5%	5%	5%
Turn Type	Prot			Perm		pt+ov	Prot		Perm	Prot		pm+ov
Protected Phases	3	8			4	4 5	1	6		5	2	3
Permitted Phases				4					6			2
Actuated Green, G (s)	7.9	47.0			32.0	55.6	3.9	96.4	96.4	16.5	109.0	116.9
Effective Green, g (s)	7.9	47.0			32.0	55.6	3.9	96.4	96.4	16.5	109.0	116.9
Actuated g/C Ratio	0.04	0.26			0.17	0.30	0.02	0.53	0.53	0.09	0.60	0.64
Clearance Time (s)	8.1	8.1			7.1		7.5	7.5	7.5	7.5	7.5	8.1
Vehicle Extension (s)	6.0	6.0			6.0		6.0	8.0	8.0	6.0	8.0	6.0
Lane Grp Cap (vph)	50	280			224	785	37	1811	810	301	2048	982
v/s Ratio Prot	c0.06	0.04				c0.38	0.01	c0.80		c0.15	0.39	0.00
v/s Ratio Perm					0.14				0.05			0.04
v/c Ratio	1.36	0.14			0.78	1.23	0.57	1.53	0.09	1.70	0.66	0.06
Uniform Delay, d <sub>1</sub>	87.5	52.4			72.1	63.7	88.7	43.3	21.5	83.2	24.6	12.4
Progression Factor	1.00	1.00			1.00	1.00	1.00	1.00	1.00	1.00	1.00	1.00
Incremental Delay, d <sub>2</sub>	250.1	0.6			19.1	116.4	35.4	240.1	0.2	327.9	1.7	0.1
Delay (s)	337.6	53.1			91.2	180.1	124.1	283.4	21.8	411.1	26.3	12.5
Level of Service	F	D			F	F	F	F	C	F	C	B
Approach Delay (s)		233.9			166.6			274.4			126.4	
Approach LOS		F			F			F			F	

Intersection Summary			
HCM Average Control Delay	205.9	HCM Level of Service	F
HCM Volume to Capacity ratio	1.51		
Actuated Cycle Length (s)	183.0	Sum of lost time (s)	30.2
Intersection Capacity Utilization	128.8%	ICU Level of Service	H
Analysis Period (min)	15		

c Critical Lane Group

# HCM Signalized Intersection Capacity Analysis

## 17: Port Sutton Rd & US 41

7/23/2013



Movement	EBL	EBR	NBL	NBT	SBU	SBT	SBR
Lane Configurations	↙	↘	↙	↑↑	⊠	↑↑	↘
Volume (vph)	56	20	38	3295	10	1831	129
Ideal Flow (vphpl)	1900	1900	1900	1900	1900	1900	1900
Total Lost time (s)	7.7	7.0	7.0	6.7	6.4	6.7	7.7
Lane Util. Factor	1.00	1.00	1.00	0.95	1.00	0.95	1.00
Fr <sub>t</sub>	1.00	0.85	1.00	1.00	1.00	1.00	0.85
Flt Protected	0.95	1.00	0.95	1.00	0.95	1.00	1.00
Satd. Flow (prot)	1271	1137	1719	3438	1719	3438	1538
Flt Permitted	0.95	1.00	0.06	1.00	0.04	1.00	1.00
Satd. Flow (perm)	1271	1137	115	3438	67	3438	1538
Peak-hour factor, PHF	0.95	0.95	0.95	0.95	0.95	0.95	0.95
Adj. Flow (vph)	59	21	40	3468	11	1927	136
RTOR Reduction (vph)	0	11	0	0	0	0	23
Lane Group Flow (vph)	59	10	40	3468	11	1927	113
Heavy Vehicles (%)	42%	42%	5%	5%	5%	5%	5%
Turn Type		pm+ov	pm+pt		pm+pt		pm+ov
Protected Phases	8	1	1	6	5	2	8
Permitted Phases		8	6		2		2
Actuated Green, G (s)	14.9	18.8	114.3	110.4	109.7	107.8	122.7
Effective Green, g (s)	14.9	18.8	114.3	110.4	109.7	107.8	122.7
Actuated g/C Ratio	0.10	0.13	0.77	0.75	0.74	0.73	0.83
Clearance Time (s)	7.7	7.0	7.0	6.7	6.4	6.7	7.7
Vehicle Extension (s)	6.0	3.0	3.0	8.0	3.0	8.0	6.0
Lane Grp Cap (vph)	128	144	131	2565	71	2504	1275
v/s Ratio Prot	c0.05	0.00	c0.01	c1.01	0.00	0.56	0.01
v/s Ratio Perm		0.01	0.23		0.11		0.06
v/c Ratio	0.46	0.07	0.31	1.35	0.15	0.77	0.09
Uniform Delay, d1	62.8	56.9	13.5	18.8	41.6	12.4	2.3
Progression Factor	1.00	1.00	1.00	1.00	1.00	1.00	1.00
Incremental Delay, d2	7.2	0.2	1.3	161.1	1.0	2.3	0.1
Delay (s)	70.0	57.1	14.9	179.9	42.6	14.8	2.4
Level of Service	E	E	B	F	D	B	A
Approach Delay (s)	66.6			178.0		14.1	
Approach LOS	E			F		B	

### Intersection Summary

HCM Average Control Delay	116.4	HCM Level of Service	F
HCM Volume to Capacity ratio	1.24		
Actuated Cycle Length (s)	148.0	Sum of lost time (s)	21.4
Intersection Capacity Utilization	108.9%	ICU Level of Service	G
Analysis Period (min)	15		

c Critical Lane Group



## TWO-WAY STOP CONTROL SUMMARY

Analyst: AG  
 Agency/Co.: American  
 Date Performed: 06/17/2013  
 Analysis Time Period: AM Peak  
 Intersection: Hartford St & US 41  
 Jurisdiction: FDOT D7  
 Units: U. S. Customary  
 Analysis Year: 2040 No Build  
 Project ID: US 41 PD&E Study  
 East/West Street: Hartford St  
 North/South Street: US 41  
 Intersection Orientation: NS

Study period (hrs): 0.25

## Vehicle Volumes and Adjustments

Major Street:	Approach Movement	Northbound			Southbound		
		1 L	2 T	3 R	4 L	5 T	6 R

Volume	14	2323	27	113	1370	37
Peak-Hour Factor, PHF	0.95	0.95	0.95	0.95	0.95	0.95
Hourly Flow Rate, HFR	14	2445	28	118	1442	38
Percent Heavy Vehicles	5	--	--	5	--	--
Median Type/Storage	Raised curb			/ 1		
RT Channelized?						
Lanes	1	2	0	1	2	0
Configuration	L	T	TR	L	T	TR
Upstream Signal?	No			No		

Minor Street:	Approach Movement	Westbound			Eastbound		
		7 L	8 T	9 R	10 L	11 T	12 R

Volume	24	0	121	5	0	3
Peak Hour Factor, PHF	0.95	0.95	0.95	0.95	0.95	0.95
Hourly Flow Rate, HFR	25	0	127	5	0	3
Percent Heavy Vehicles	27	27	27	0	0	0
Percent Grade (%)	0		0			
Flared Approach: Exists?/Storage			No	/	No /	
Lanes	0	1	0	0	1	0
Configuration	LTR			LTR		

## Delay, Queue Length, and Level of Service

Approach	NB	SB	Westbound			Eastbound		
			7	8	9	10	11	12

Movement	1	4	7	8	9	10	11	12
Lane Config	L	L	LTR	LTR	LTR	LTR	LTR	LTR
v (vph)	14	118	152			8		
C(m) (vph)	436	176				0		
v/c	0.03	0.67						
95% queue length	0.10	3.95						
Control Delay	13.5	59.3						
LOS	B	F				F		

Approach Delay  
 Approach LOS

Arterial Level of Service: NB US 41

Cross Street	Arterial Class	Flow Speed	Running Time	Signal Delay	Travel Time (s)	Dist (mi)	Arterial Speed	Arterial LOS
Symmes Rd		55	134.1	147.2	281.3	2.03	26.0	D
Palm Ave.		42	40.6	95.1	135.7	0.42	11.2	F
Gibsonston Dr		50	42.1	185.3	227.4	0.59	9.3	F
Riverview Dr		50	74.5	252.0	326.5	1.03	11.4	F
CR 676A (Madison Ave		55	181.6	282.3	463.9	2.77	21.5	D
Port Sutton Rd		50	32.5	165.8	198.3	0.36	6.5	F
CR 676		50	83.3	188.8	272.1	1.16	15.3	F
Total			588.7	1316.5	1905.2	8.36	15.8	F

Arterial Level of Service: SB US 41

Cross Street	Arterial Class	Flow Speed	Running Time	Signal Delay	Travel Time (s)	Dist (mi)	Arterial Speed	Arterial LOS
Causeway Blvd		50	20.0	145.8	165.8	0.20	4.3	F
Port Sutton Rd		50	83.3	15.7	99.0	1.16	42.1	A
Pendola Point Rd		50	32.5	25.7	58.2	0.36	22.1	D
Industrial Access Rd		55	181.6	30.2	211.8	2.77	47.2	A
Alice Ave		50	74.5	17.6	92.1	1.03	40.5	B
Palm Ave.		50	42.1	5.6	47.7	0.59	44.2	A
Symmes Rd		50	36.3	17.8	54.1	0.42	28.1	C
Total			470.3	258.4	728.7	6.53	32.3	C

TWO-WAY STOP CONTROL SUMMARY

Analyst: AG  
 Agency/Co.: American  
 Date Performed: 06/17/2013  
 Analysis Time Period: PM Peak  
 Intersection: Kracker Avenue & US 41  
 Jurisdiction: FDOT D7  
 Units: U. S. Customary  
 Analysis Year: 2040 No Build  
 Project ID: US 41 PD&E Study  
 East/West Street: Kracker Ave  
 North/South Street: US 41  
 Intersection Orientation: NS  
 Study period (hrs): 0.25

Vehicle Volumes and Adjustments

Major Street:	Approach Movement	Northbound			Southbound		
		1 L	2 T	3 R	4 L	5 T	6 R
Volume		10	1339	14	7	2423	5
Peak-Hour Factor, PHF		0.95	0.95	0.95	0.95	0.95	0.95
Hourly Flow Rate, HFR		10	1409	14	7	2550	5
Percent Heavy Vehicles		5	--	--	5	--	--
Median Type/Storage		Raised curb			/ 1		
RT Channelized?		Yes			Yes		
Lanes		1	2	1	1	2	1
Configuration		L	T	R	L	T	R
Upstream Signal?		No			No		

Minor Street:	Approach Movement	Westbound			Eastbound		
		7 L	8 T	9 R	10 L	11 T	12 R
Volume		14	2	14	6	0	6
Peak Hour Factor, PHF		0.95	0.95	0.95	0.95	0.95	0.95
Hourly Flow Rate, HFR		14	2	14	6	0	6
Percent Heavy Vehicles		15	15	15	0	0	0
Percent Grade (%)		0			0		
Flared Approach: Exists?/Storage					/		
Lanes		0	1	1	0	1	1
Configuration		LT		R	LT		R

Delay, Queue Length, and Level of Service

Approach Movement	NB	SB	Westbound			Eastbound		
			7 LT	8 R	9 R	10 LT	11 R	12 R
Lane Config	L	L	LT	R	R	LT	R	R
v (vph)	10	7	16		14	6		6
C(m) (vph)	163	465	52		402	23		206
v/c	0.06	0.02	0.31		0.03	0.26		0.03
95% queue length	0.19	0.05	1.08		0.11	0.78		0.09
Control Delay	28.5	12.9	102.4		14.3	209.8		23.0
LOS	D	B	F		B	F		C
Approach Delay				61.3				116.4
Approach LOS				F				F

TWO-WAY STOP CONTROL SUMMARY

Analyst: AG  
 Agency/Co.: American  
 Date Performed: 06/17/2013  
 Analysis Time Period: PM Peak  
 Intersection: Ohio Street & US 41  
 Jurisdiction: FDOT D7  
 Units: U. S. Customary  
 Analysis Year: 2040 No Build  
 Project ID: US 41 PD&E Study  
 East/West Street: Ohio Street  
 North/South Street: US 41  
 Intersection Orientation: NS Study period (hrs): 0.25

Vehicle Volumes and Adjustments

Major Street: Approach Movement	Northbound			Southbound		
	1 L	2 T	3 R	4 L	5 T	6 R
Volume		1334	20	113	2131	
Peak-Hour Factor, PHF		0.95	0.95	0.95	0.95	
Hourly Flow Rate, HFR		1404	21	118	2243	
Percent Heavy Vehicles		--	--	5	--	--
Median Type/Storage		Raised curb		/ 1		
RT Channelized?						
Lanes		2	0		1	2
Configuration		T	TR		L	T
Upstream Signal?		No			No	

Minor Street: Approach Movement	Westbound			Eastbound		
	7 L	8 T	9 R	10 L	11 T	12 R
Volume	25		45			
Peak Hour Factor, PHF	0.95		0.95			
Hourly Flow Rate, HFR	26		47			
Percent Heavy Vehicles	0		0			
Percent Grade (%)		0			0	
Flared Approach: Exists?/Storage			No	/		/
Lanes	0		0			
Configuration		LR				

Delay, Queue Length, and Level of Service

Approach Movement	NB	SB	Westbound			Eastbound		
	1	4	7	8	9	10	11	12
Lane Config		L		LR				
v (vph)		118		73				
C(m) (vph)		458		175				
v/c		0.26		0.42				
95% queue length		1.02		1.87				
Control Delay		15.6		39.5				
LOS		C		E				
Approach Delay				39.5				
Approach LOS				E				

## TWO-WAY STOP CONTROL SUMMARY

Analyst: AG  
 Agency/Co.: American  
 Date Performed: 06/17/2013  
 Analysis Time Period: PM Peak  
 Intersection: Florence St & US 41  
 Jurisdiction: FDOT D7  
 Units: U. S. Customary  
 Analysis Year: 2040 No Build  
 Project ID: US 41 PD&E Study  
 East/West Street: Florence Street  
 North/South Street: US 41  
 Intersection Orientation: NS Study period (hrs): 0.25

## Vehicle Volumes and Adjustments

Major Street:	Approach Movement	Northbound			Southbound		
		1 L	2 T	3 R	4 L	5 T	6 R
Volume		13	1233	2	7	2228	20
Peak-Hour Factor, PHF		0.95	0.95	0.95	0.95	0.95	0.95
Hourly Flow Rate, HFR		13	1297	2	7	2345	21
Percent Heavy Vehicles		5	--	--	5	--	--
Median Type/Storage		Raised curb			/ 1		
RT Channelized?							
Lanes		1	2	0	1	2	0
Configuration		L	T	TR	L	T	TR
Upstream Signal?		No			No		

Minor Street:	Approach Movement	Westbound			Eastbound		
		7 L	8 T	9 R	10 L	11 T	12 R
Volume		5	0	15	24	0	10
Peak Hour Factor, PHF		0.95	0.95	0.95	0.95	0.95	0.95
Hourly Flow Rate, HFR		5	0	15	25	0	10
Percent Heavy Vehicles		0	0	0	0	0	0
Percent Grade (%)		0			0		
Flared Approach: Exists?/Storage		No			/ No /		
Lanes		0	1	0	0	1	0
Configuration		LTR			LTR		

## Delay, Queue Length, and Level of Service

Approach Movement	NB 1 L	SB 4 L	Westbound			Eastbound		
			7	8 LTR	9	10	11 LTR	12
v (vph)	13	7	20			35		
C(m) (vph)	194	513	216			41		
v/c	0.07	0.01	0.09			0.85		
95% queue length	0.21	0.04	0.30			3.27		
Control Delay	24.9	12.1	23.4			246.5		
LOS	C	B	C			F		
Approach Delay			23.4			246.5		
Approach LOS			C			F		

HCM Signalized Intersection Capacity Analysis  
 35: Symmes Rd & US 41

7/23/2013



Movement	EBL	EBT	EBR	WBL	WBT	WBR	NBL	NBT	NBR	SBL	SBT	SBR
Lane Configurations		↕		↙	↘			↕	↙	↘	↕	
Volume (vph)	0	2	0	215	0	244	3	1115	134	535	2063	5
Ideal Flow (vphpl)	1900	1900	1900	1900	1900	1900	1900	1900	1900	1900	1900	1900
Total Lost time (s)		7.2		7.2	7.2			6.2	6.2	7.0	6.2	
Lane Util. Factor		1.00		1.00	1.00			0.95	1.00	1.00	0.95	
Fr't		1.00		1.00	0.85			1.00	0.85	1.00	1.00	
Flt Protected		1.00		0.95	1.00			1.00	1.00	0.95	1.00	
Satd. Flow (prot)		1900		1736	1553			3438	1538	1719	3437	
Flt Permitted		1.00		0.76	1.00			0.95	1.00	0.07	1.00	
Satd. Flow (perm)		1900		1382	1553			3252	1538	121	3437	
Peak-hour factor, PHF	0.95	0.95	0.95	0.95	0.95	0.95	0.95	0.95	0.95	0.95	0.95	0.95
Adj. Flow (vph)	0	2	0	226	0	257	3	1174	141	563	2172	5
RTOR Reduction (vph)	0	0	0	0	0	0	0	0	58	0	0	0
Lane Group Flow (vph)	0	2	0	226	257	0	0	1177	83	563	2177	0
Heavy Vehicles (%)	0%	0%	0%	4%	4%	4%	5%	5%	5%	5%	5%	5%
Turn Type	Perm			Perm			Perm		Perm	pm+pt		
Protected Phases		8			4			6			5	2
Permitted Phases	8			4			6		6		2	
Actuated Green, G (s)		27.9		27.9	27.9			52.8	52.8	97.9	97.9	
Effective Green, g (s)		27.9		27.9	27.9			52.8	52.8	97.9	97.9	
Actuated g/C Ratio		0.20		0.20	0.20			0.38	0.38	0.70	0.70	
Clearance Time (s)		7.2		7.2	7.2			6.2	6.2	7.0	6.2	
Vehicle Extension (s)		3.0		3.0	3.0			4.0	4.0	3.0	4.0	
Lane Grp Cap (vph)		381		277	311			1234	583	522	2417	
v/s Ratio Prot		0.00			c0.17					c0.29	0.63	
v/s Ratio Perm				0.16				0.36	0.05	c0.46		
v/c Ratio		0.01		0.82	0.83			0.95	0.14	1.08	0.90	
Uniform Delay, d1		44.5		53.2	53.3			42.0	28.3	43.8	16.7	
Progression Factor		1.00		1.00	1.00			1.00	1.00	1.00	1.00	
Incremental Delay, d2		0.0		16.7	16.2			15.9	0.2	62.2	5.2	
Delay (s)		44.5		69.9	69.6			57.9	28.5	106.1	21.9	
Level of Service		D		E	E			E	C	F	C	
Approach Delay (s)		44.5			69.7			54.7			39.2	
Approach LOS		D			E			D			D	

Intersection Summary

HCM Average Control Delay	47.0	HCM Level of Service	D
HCM Volume to Capacity ratio	0.99		
Actuated Cycle Length (s)	139.2	Sum of lost time (s)	14.2
Intersection Capacity Utilization	123.0%	ICU Level of Service	H
Analysis Period (min)	15		

c Critical Lane Group

HCM Signalized Intersection Capacity Analysis  
 46: Palm Ave. & US 41

7/23/2013

Movement	EBL	EBT	EBR	WBL	WBT	WBR	NBL	NBT	NBR	SBL	SBT	SBR
Lane Configurations		↔		↙	↘		↙	↕	↘	↙	↕	↘
Volume (vph)	38	4	6	22	1	30	7	1426	15	66	2496	26
Ideal Flow (vphpl)	1900	1900	1900	1900	1900	1900	1900	1900	1900	1900	1900	1900
Total Lost time (s)		6.7		6.7	6.7		6.2	6.2	6.2	6.5	6.5	
Lane Util. Factor		1.00		1.00	1.00		1.00	0.95	1.00	1.00	0.95	
Frt		0.98		1.00	0.85		1.00	1.00	0.85	1.00	1.00	
Flt Protected		0.96		0.95	1.00		0.95	1.00	1.00	0.95	1.00	
Satd. Flow (prot)		1728		1805	1624		1719	3438	1538	1719	3433	
Flt Permitted		0.75		0.72	1.00		0.07	1.00	1.00	0.07	1.00	
Satd. Flow (perm)		1342		1376	1624		131	3438	1538	131	3433	
Peak-hour factor, PHF	0.95	0.95	0.95	0.95	0.95	0.95	0.95	0.95	0.95	0.95	0.95	0.95
Adj. Flow (vph)	40	4	6	23	1	32	7	1501	16	69	2627	27
RTOR Reduction (vph)	0	0	0	0	0	0	0	0	6	0	0	0
Lane Group Flow (vph)	0	50	0	23	33	0	7	1501	10	69	2654	0
Heavy Vehicles (%)	4%	4%	4%	0%	0%	0%	5%	5%	5%	5%	5%	5%
Turn Type	Perm			Perm			Perm		Perm	pm+pt		
Protected Phases		4			4			2			1	1 2
Permitted Phases	4			4			2		2		1 2	
Actuated Green, G (s)		9.7		9.7	9.7		55.1	55.1	55.1		88.6	95.1
Effective Green, g (s)		9.7		9.7	9.7		55.1	55.1	55.1		88.6	95.1
Actuated g/C Ratio		0.08		0.08	0.08		0.47	0.47	0.47		0.75	0.81
Clearance Time (s)		6.7		6.7	6.7		6.2	6.2	6.2		6.5	
Vehicle Extension (s)		3.0		3.0	3.0		4.0	4.0	4.0		2.5	
Lane Grp Cap (vph)		111		113	134		61	1609	720		551	2774
v/s Ratio Prot					0.02			0.44			0.04	c0.77
v/s Ratio Perm		c0.04		0.02			0.05		0.01		0.06	
v/c Ratio		0.45		0.20	0.25		0.11	0.93	0.01		0.13	0.96
Uniform Delay, d1		51.5		50.4	50.6		17.6	29.6	16.8		12.6	9.6
Progression Factor		1.00		1.00	1.00		1.00	1.00	1.00		1.00	1.00
Incremental Delay, d2		2.9		0.9	1.0		1.1	10.4	0.0		0.1	9.0
Delay (s)		54.4		51.3	51.5		18.7	40.0	16.8		12.6	18.6
Level of Service		D		D	D		B	D	B		B	B
Approach Delay (s)		54.4			51.4			39.6				18.4
Approach LOS		D			D			D				B

Intersection Summary			
HCM Average Control Delay	26.7	HCM Level of Service	C
HCM Volume to Capacity ratio	0.91		
Actuated Cycle Length (s)	117.7	Sum of lost time (s)	13.2
Intersection Capacity Utilization	90.2%	ICU Level of Service	E
Analysis Period (min)	15		

c Critical Lane Group

TWO-WAY STOP CONTROL SUMMARY

Analyst: AG  
 Agency/Co.: American  
 Date Performed: 06/17/2013  
 Analysis Time Period: PM Peak  
 Intersection: Nundy Ave & US 41  
 Jurisdiction: FDOT D7  
 Units: U. S. Customary  
 Analysis Year: 2040 No Build  
 Project ID: US 41 PD&E Study  
 East/West Street: Nundy Ave  
 North/South Street: US 41  
 Intersection Orientation: NS

Study period (hrs): 0.25

Vehicle Volumes and Adjustments

Major Street:	Approach Movement	Northbound			Southbound		
		1 L	2 T	3 R	4 L	5 T	6 R
Volume		16	1345	78	72	2533	11
Peak-Hour Factor, PHF		0.95	0.95	0.95	0.95	0.95	0.95
Hourly Flow Rate, HFR		16	1415	82	75	2666	11
Percent Heavy Vehicles		5	--	--	5	--	--
Median Type/Storage		Raised curb			/ 1		
RT Channelized?							
Lanes		1	2	0	1	2	0
Configuration		L	T	TR	L	T	TR
Upstream Signal?		No			Yes		

Minor Street:	Approach Movement	Westbound			Eastbound		
		7 L	8 T	9 R	10 L	11 T	12 R
Volume		95	4	51	7	0	21
Peak Hour Factor, PHF		0.95	0.95	0.95	0.95	0.95	0.95
Hourly Flow Rate, HFR		100	4	53	7	0	22
Percent Heavy Vehicles		3	3	3	0	0	0
Percent Grade (%)		0			0		
Flared Approach: Exists?/Storage		No			/ No /		
Lanes		0	1	0	0	1	0
Configuration		LTR			LTR		

Delay, Queue Length, and Level of Service

Approach Movement	NB	SB	Westbound			Eastbound		
			7	8	9	10	11	12
Lane Config	L	L	LTR			LTR		
v (vph)	16	75	157			29		
C(m) (vph)	87	430	0					
v/c	0.18	0.17						
95% queue length	0.63	0.63						
Control Delay	55.5	15.1						
LOS	F	C	F					
Approach Delay								
Approach LOS								



# HCM Signalized Intersection Capacity Analysis

40: Alice Ave & US 41

7/23/2013



Movement	EBL	EBT	EBR	WBL	WBT	WBR	NBL	NBT	NBR	SBL	SBT	SBR
Lane Configurations		↕		↙	↘	↗	↖	↕	↗	↖	↕	↗
Volume (vph)	12	27	19	573	77	239	16	996	442	722	2356	25
Ideal Flow (vphpl)	1900	1900	1900	1900	1900	1900	1900	1900	1900	1900	1900	1900
Total Lost time (s)		9.0		9.0	9.0	6.7	6.1	6.1	6.1	6.7	6.1	
Lane Util. Factor		1.00		1.00	1.00	1.00	1.00	0.95	1.00	1.00	0.95	
Frt		0.96		1.00	1.00	0.85	1.00	1.00	0.85	1.00	1.00	
Flt Protected		0.99		0.95	1.00	1.00	0.95	1.00	1.00	0.95	1.00	
Satd. Flow (prot)		1695		1719	1810	1538	1719	3438	1538	1719	3433	
Flt Permitted		0.94		0.72	1.00	1.00	0.10	1.00	1.00	0.09	1.00	
Satd. Flow (perm)		1607		1298	1810	1538	181	3438	1538	155	3433	
Peak-hour factor, PHF	0.95	0.95	0.95	0.95	0.95	0.95	0.95	0.95	0.95	0.95	0.95	0.95
Adj. Flow (vph)	13	28	20	603	81	252	17	1048	465	760	2480	26
RTOR Reduction (vph)	0	0	0	0	0	0	0	0	155	0	0	0
Lane Group Flow (vph)	0	61	0	603	81	252	17	1048	310	760	2506	0
Heavy Vehicles (%)	6%	6%	6%	5%	5%	5%	5%	5%	5%	5%	5%	5%
Turn Type	Perm			Perm		pm+ov	Perm		Perm		pm+pt	
Protected Phases		8			4	5		6			5	2
Permitted Phases	8			4		4	6		6		2	
Actuated Green, G (s)		43.0		43.0	43.0	83.3	39.9	39.9	39.9		86.9	86.9
Effective Green, g (s)		43.0		43.0	43.0	83.3	39.9	39.9	39.9		86.9	86.9
Actuated g/C Ratio		0.30		0.30	0.30	0.57	0.28	0.28	0.28		0.60	0.60
Clearance Time (s)		9.0		9.0	9.0	6.7	6.1	6.1	6.1		6.7	6.1
Vehicle Extension (s)		3.0		6.0	6.0	3.0	8.0	8.0	8.0		3.0	8.0
Lane Grp Cap (vph)		477		385	537	884	50	946	423		528	2057
v/s Ratio Prot					0.04	0.08		0.30			c0.40	0.73
v/s Ratio Perm		0.04		c0.46		0.08	0.09		0.20		c0.46	
v/c Ratio		0.13		1.57	0.15	0.29	0.34	1.11	0.73		1.44	1.22
Uniform Delay, d1		37.3		51.0	37.6	15.7	42.0	52.5	47.7		44.8	29.0
Progression Factor		1.00		1.00	1.00	1.00	1.00	1.00	1.00		1.00	1.00
Incremental Delay, d2		0.6		267.1	0.6	0.8	17.5	63.5	10.7		208.3	102.9
Delay (s)		37.8		318.1	38.2	16.5	59.5	116.0	58.4		253.1	131.9
Level of Service		D		F	D	B	E	F	E		F	F
Approach Delay (s)		37.8			212.7			97.9				160.1
Approach LOS		D			F			F				F

## Intersection Summary

HCM Average Control Delay	150.9	HCM Level of Service	F
HCM Volume to Capacity ratio	1.45		
Actuated Cycle Length (s)	145.0	Sum of lost time (s)	15.7
Intersection Capacity Utilization	134.5%	ICU Level of Service	H
Analysis Period (min)	15		

c Critical Lane Group

# HCM Signalized Intersection Capacity Analysis

## 9: Industrial Access Rd & US 41

7/23/2013



Movement	EBL	EBT	EBR	WBL	WBT	WBR	NBL	NBT	NBR	SBL	SBT	SBR
Lane Configurations		↖	↗		↖	↗	↘	↑↑	↖	↘	↑↑	↗
Volume (vph)	33	55	68	702	14	68	25	1213	488	164	2549	17
Ideal Flow (vphpl)	1900	1900	1900	1900	1900	1900	1900	1900	1900	1900	1900	1900
Total Lost time (s)		6.3	6.3		6.3	6.3	6.4	6.4	6.4	6.4	6.4	6.4
Lane Util. Factor		1.00	1.00		1.00	1.00	1.00	0.95	1.00	1.00	0.95	1.00
Fr <sub>t</sub>		1.00	0.85		1.00	0.85	1.00	1.00	0.85	1.00	1.00	0.85
Fl <sub>t</sub> Protected		0.98	1.00		0.95	1.00	0.95	1.00	1.00	0.95	1.00	1.00
Satd. Flow (prot)		1846	1599		1776	1583	1719	3438	1538	1719	3438	1538
Fl <sub>t</sub> Permitted		0.19	1.00		0.66	1.00	0.04	1.00	1.00	0.16	1.00	1.00
Satd. Flow (perm)		355	1599		1235	1583	77	3438	1538	283	3438	1538
Peak-hour factor, PHF	0.95	0.95	0.95	0.95	0.95	0.95	0.95	0.95	0.95	0.95	0.95	0.95
Adj. Flow (vph)	35	58	72	739	15	72	26	1277	514	173	2683	18
RTOR Reduction (vph)	0	0	2	0	0	16	0	0	190	0	0	4
Lane Group Flow (vph)	0	93	70	0	754	56	26	1277	324	173	2683	14
Heavy Vehicles (%)	1%	1%	1%	2%	2%	2%	5%	5%	5%	5%	5%	5%
Turn Type	Perm		Perm	Perm		Perm	Perm		Perm	Perm		Perm
Protected Phases		4			4			2			2	
Permitted Phases	4		4	4		4	2		2	2		2
Actuated Green, G (s)		42.7	42.7		42.7	42.7	94.6	94.6	94.6	94.6	94.6	94.6
Effective Green, g (s)		42.7	42.7		42.7	42.7	94.6	94.6	94.6	94.6	94.6	94.6
Actuated g/C Ratio		0.28	0.28		0.28	0.28	0.63	0.63	0.63	0.63	0.63	0.63
Clearance Time (s)		6.3	6.3		6.3	6.3	6.4	6.4	6.4	6.4	6.4	6.4
Vehicle Extension (s)		6.0	6.0		6.0	6.0	8.0	8.0	8.0	8.0	8.0	8.0
Lane Grp Cap (vph)		101	455		352	451	49	2168	970	178	2168	970
v/s Ratio Prot								0.37			c0.78	
v/s Ratio Perm		0.26	0.04		c0.61	0.04	0.34		0.21	0.61		0.01
v/c Ratio		0.92	0.15		2.14	0.12	0.53	0.59	0.33	0.97	1.24	0.01
Uniform Delay, d <sub>1</sub>		52.0	40.1		53.6	39.8	15.4	16.3	13.0	26.4	27.7	10.3
Progression Factor		1.00	1.00		1.00	1.00	1.00	1.00	1.00	1.00	1.00	1.00
Incremental Delay, d <sub>2</sub>		67.9	0.4		523.3	0.4	35.5	1.2	0.9	60.5	111.1	0.0
Delay (s)		119.9	40.6		577.0	40.1	50.9	17.5	13.9	86.9	138.8	10.4
Level of Service		F	D		F	D	D	B	B	F	F	B
Approach Delay (s)		85.3			530.2			16.9		134.8		
Approach LOS		F			F			B		F		

Intersection Summary	
HCM Average Control Delay	153.2
HCM Volume to Capacity ratio	1.52
Actuated Cycle Length (s)	150.0
Intersection Capacity Utilization	145.2%
Analysis Period (min)	15
HCM Level of Service	F
Sum of lost time (s)	12.7
ICU Level of Service	H

c Critical Lane Group

HCM Signalized Intersection Capacity Analysis  
 10: Pendola Point Rd & US 41

7/23/2013



Movement	EBL	EBT	EBR	WBL	WBT	WBR	NBL	NBT	NBR	SBL	SBT	SBR
Lane Configurations	↖	↗			↖	↗	↖	↗	↗	↖	↗	↖
Volume (vph)	134	64	14	191	0	350	3	1441	75	647	2678	8
Ideal Flow (vphpl)	1900	1900	1900	1900	1900	1900	1900	1900	1900	1900	1900	1900
Total Lost time (s)	8.1	8.1			7.1	7.1	7.5	7.5	7.5	7.5	7.5	8.1
Lane Util. Factor	1.00	1.00			1.00	0.88	1.00	0.95	1.00	0.97	0.95	1.00
Fr <sub>t</sub>	1.00	0.97			1.00	0.85	1.00	1.00	0.85	1.00	1.00	0.85
Fit Protected	0.95	1.00			0.95	1.00	0.95	1.00	1.00	0.95	1.00	1.00
Satd. Flow (prot)	1583	1621			1656	2608	1719	3438	1538	3335	3438	1538
Fit Permitted	0.95	1.00			0.70	1.00	0.95	1.00	1.00	0.95	1.00	1.00
Satd. Flow (perm)	1583	1621			1227	2608	1719	3438	1538	3335	3438	1538
Peak-hour factor, PHF	0.95	0.95	0.95	0.95	0.95	0.95	0.95	0.95	0.95	0.95	0.95	0.95
Adj. Flow (vph)	141	67	15	201	0	368	3	1517	79	681	2819	8
RTOR Reduction (vph)	0	0	0	0	0	0	0	0	18	0	0	1
Lane Group Flow (vph)	141	82	0	0	201	368	3	1517	61	681	2819	7
Heavy Vehicles (%)	14%	14%	14%	9%	9%	9%	5%	5%	5%	5%	5%	5%
Turn Type	Prot			Perm		pt+ov	Prot		Perm	Prot		pm+ov
Protected Phases	3	8			4	4 5	1	6		5		2 3
Permitted Phases				4					6			2
Actuated Green, G (s)	15.9	49.0			26.0	58.6	1.2	88.4	88.4	25.5	112.7	128.6
Effective Green, g (s)	15.9	49.0			26.0	58.6	1.2	88.4	88.4	25.5	112.7	128.6
Actuated g/C Ratio	0.09	0.26			0.14	0.32	0.01	0.48	0.48	0.14	0.61	0.69
Clearance Time (s)	8.1	8.1			7.1		7.5	7.5	7.5	7.5	7.5	8.1
Vehicle Extension (s)	6.0	6.0			6.0		6.0	8.0	8.0	6.0	8.0	6.0
Lane Grp Cap (vph)	135	427			172	822	11	1634	731	457	2083	1063
v/s Ratio Prot	c0.09	0.05				0.14	0.00	0.44		c0.20	c0.82	0.00
v/s Ratio Perm					c0.16				0.04			0.00
v/c Ratio	1.04	0.19			1.17	0.45	0.27	0.93	0.08	1.49	1.35	0.01
Uniform Delay, d <sub>1</sub>	85.0	53.1			80.0	50.8	92.0	45.8	26.7	80.2	36.6	8.9
Progression Factor	1.00	1.00			1.00	1.00	1.00	1.00	1.00	1.00	1.00	1.00
Incremental Delay, d <sub>2</sub>	89.8	0.6			121.3	1.1	34.4	10.7	0.2	232.0	162.2	0.0
Delay (s)	174.8	53.8			201.3	51.9	126.4	56.5	26.9	312.2	198.9	8.9
Level of Service	F	D			F	D	F	E	C	F	F	A
Approach Delay (s)		130.3			104.7			55.2			220.5	
Approach LOS		F			F			E			F	

Intersection Summary

HCM Average Control Delay	161.1	HCM Level of Service	F
HCM Volume to Capacity ratio	1.34		
Actuated Cycle Length (s)	186.0	Sum of lost time (s)	30.2
Intersection Capacity Utilization	113.9%	ICU Level of Service	H
Analysis Period (min)	15		

c Critical Lane Group

HCM Signalized Intersection Capacity Analysis  
 17: Port Sutton Rd & US 41

7/23/2013



Movement	EBL	EBR	NBL	NBT	SBU	SBT	SBR
Lane Configurations	↙	↗	↙	↕	↕	↕	↗
Volume (vph)	139	98	0	1853	2	3519	7
Ideal Flow (vphpl)	1900	1900	1900	1900	1900	1900	1900
Total Lost time (s)	7.7	7.0		6.7	6.4	6.7	7.7
Lane Util. Factor	1.00	1.00		0.95	1.00	0.95	1.00
Fr <sub>t</sub>	1.00	0.85		1.00	1.00	1.00	0.85
Fl <sub>t</sub> Protected	0.95	1.00		1.00	0.95	1.00	1.00
Satd. Flow (prot)	1805	1615		3438	1719	3438	1538
Fl <sub>t</sub> Permitted	0.95	1.00		1.00	0.06	1.00	1.00
Satd. Flow (perm)	1805	1615		3438	117	3438	1538
Peak-hour factor, PHF	0.95	0.95	0.95	0.95	0.95	0.95	0.95
Adj. Flow (vph)	146	103	0	1951	2	3704	7
RTOR Reduction (vph)	0	0	0	0	0	0	1
Lane Group Flow (vph)	146	103	0	1951	2	3704	6
Heavy Vehicles (%)	0%	0%	5%	5%	5%	5%	5%
Turn Type		pm+ov	pm+pt		pm+pt		pm+ov
Protected Phases	8	1	1	6	5	2	8
Permitted Phases		8	6		2		2
Actuated Green, G (s)	20.2	25.2		114.1	110.7	109.6	129.8
Effective Green, g (s)	20.2	25.2		114.1	110.7	109.6	129.8
Actuated g/C Ratio	0.13	0.16		0.73	0.71	0.70	0.83
Clearance Time (s)	7.7	7.0		6.7	6.4	6.7	7.7
Vehicle Extension (s)	6.0	3.0		8.0	3.0	8.0	6.0
Lane Grp Cap (vph)	233	261		2511	94	2412	1278
v/s Ratio Prot	c0.08	c0.01		c0.57	0.00	c1.08	0.00
v/s Ratio Perm		0.05			0.01		0.00
v/c Ratio	0.63	0.39		0.78	0.02	1.54	0.00
Uniform Delay, d <sub>1</sub>	64.4	58.7		13.1	13.1	23.3	2.2
Progression Factor	1.00	1.00		1.00	1.00	1.00	1.00
Incremental Delay, d <sub>2</sub>	8.7	1.0		2.4	0.1	243.2	0.0
Delay (s)	73.1	59.7		15.6	13.2	266.5	2.2
Level of Service	E	E		B	B	F	A
Approach Delay (s)	67.5			15.6		265.8	
Approach LOS	E			B		F	

Intersection Summary			
HCM Average Control Delay	174.9	HCM Level of Service	F
HCM Volume to Capacity ratio	1.44		
Actuated Cycle Length (s)	156.2	Sum of lost time (s)	28.1
Intersection Capacity Utilization	117.0%	ICU Level of Service	H
Analysis Period (min)	15		

c Critical Lane Group

TWO-WAY STOP CONTROL SUMMARY

Analyst: AG  
 Agency/Co.: American  
 Date Performed: 06/17/2013  
 Analysis Time Period: PM Peak  
 Intersection: Hartford St & US 41  
 Jurisdiction: FDOT D7  
 Units: U. S. Customary  
 Analysis Year: 2040 No Build  
 Project ID: US 41 PD&E Study  
 East/West Street: Hartford Street  
 North/South Street: US 41  
 Intersection Orientation: NS Study period (hrs): 0.25

Vehicle Volumes and Adjustments

Major Street: Approach Movement	Northbound			Southbound		
	1 L	2 T	3 R	4 L	5 T	6 R

Volume	12	1274	37	70	2595	4
Peak-Hour Factor, PHF	0.95	0.95	0.95	0.95	0.95	0.95
Hourly Flow Rate, HFR	12	1341	38	73	2731	4
Percent Heavy Vehicles	5	--	--	5	--	--
Median Type/Storage	Raised curb			/ 1		
RT Channelized?						
Lanes	1	2	0	1	2	0
Configuration	L	T	TR	L	T	TR
Upstream Signal?	No			No		

Minor Street: Approach Movement	Westbound			Eastbound		
	7 L	8 T	9 R	10 L	11 T	12 R

Volume	35	0	102	17	0	10
Peak Hour Factor, PHF	0.95	0.95	0.95	0.95	0.95	0.95
Hourly Flow Rate, HFR	36	0	107	17	0	10
Percent Heavy Vehicles	13	13	13	10	10	10
Percent Grade (%)	0		0			
Flared Approach: Exists?/Storage	No		/		No /	
Lanes	0	1	0	0	1	0
Configuration	LTR			LTR		

Delay, Queue Length, and Level of Service

Approach Movement	NB	SB	Westbound			Eastbound		
	1	4	7	8	9	10	11	12

Lane Config	L	L	LTR			LTR			
v (vph)	12	73	143			27			
C(m) (vph)	137	478	137			15			
v/c	0.09	0.15	1.04			1.80			
95% queue length	0.28	0.54	7.71			4.02			
Control Delay	33.8	13.9	152.7			901.2			
LOS	D	B	F			F			
Approach Delay				152.7			901.2		
Approach LOS				F			F		

Arterial Level of Service: NB US 41

Cross Street	Arterial Class	Flow Speed	Running Time	Signal Delay	Travel Time (s)	Dist (mi)	Arterial Speed	Arterial LOS
Symmes Rd	I	55	134.1	59.4	193.5	2.03	37.7	B
Palm Ave.	I	42	40.6	41.6	82.2	0.42	18.5	E
Gibson Dr	I	50	42.1	111.4	153.5	0.59	13.7	F
Riverview Dr	I	50	74.5	17.7	92.2	1.03	40.4	B
CR 676A (Madison Ave)	I	55	181.6	62.6	244.2	2.77	40.9	B
Port Sutton Rd	I	50	32.5	14.4	46.9	0.36	27.4	C
CR 676	I	50	83.3	198.5	281.8	1.16	14.8	F
Total	I		588.7	505.6	1094.3	8.36	27.5	C

Arterial Level of Service: SB US 41

Cross Street	Arterial Class	Flow Speed	Running Time	Signal Delay	Travel Time (s)	Dist (mi)	Arterial Speed	Arterial LOS
Causeway Blvd	I	50	20.0	326.4	346.4	0.20	2.1	F
Port Sutton Rd	I	50	83.3	276.9	360.2	1.16	11.6	F
Pendola Point Rd	I	50	32.5	173.2	205.7	0.36	6.3	F
Industrial Access Rd	I	55	181.6	138.4	320.0	2.77	31.2	C
Alice Ave	I	50	74.5	131.5	206.0	1.03	18.1	E
Palm Ave.	I	50	42.1	21.2	63.3	0.59	33.3	C
Symmes Rd	I	50	36.3	24.5	60.8	0.42	25.0	D
Total	I		470.3	1092.1	1562.4	6.53	15.0	F

TWO-WAY STOP CONTROL SUMMARY

Analyst: AG  
 Agency/Co.: American  
 Date Performed: 06/17/2013  
 Analysis Time Period: AM Peak  
 Intersection: Kracker Avenue & US 41  
 Jurisdiction: FDOT D7  
 Units: U. S. Customary  
 Analysis Year: 2040 Build  
 Project ID: US 41 PD&E Study  
 East/West Street: Kracker Ave  
 North/South Street: US 41  
 Intersection Orientation: NS Study period (hrs): 0.25

Vehicle Volumes and Adjustments

Major Street:	Approach Movement	Northbound			Southbound		
		1 L	2 T	3 R	4 L	5 T	6 R

Volume	9	1622	11	2	899	4
Peak-Hour Factor, PHF	0.95	0.95	0.95	0.95	0.95	0.95
Hourly Flow Rate, HFR	9	1707	11	2	946	4
Percent Heavy Vehicles	5	--	--	5	--	--
Median Type/Storage	Raised curb			/ 1		
RT Channelized?						
Lanes	1	2	0	1	2	0
Configuration	L	T	TR	L	T	TR
Upstream Signal?	No			No		

Minor Street:	Approach Movement	Westbound			Eastbound		
		7 L	8 T	9 R	10 L	11 T	12 R

Volume	25	0	9	8	0	13
Peak Hour Factor, PHF	0.95	0.95	0.95	0.95	0.95	0.95
Hourly Flow Rate, HFR	26	0	9	8	0	13
Percent Heavy Vehicles	0	0	0	0	0	0
Percent Grade (%)	0		0			
Flared Approach: Exists?/Storage				/		
Lanes	0	1	1	0	1	1
Configuration	LT	R		LT	R	

Delay, Queue Length, and Level of Service

Approach	NB	SB	Westbound			Eastbound		
			7 LT	8 R	9 R	10 LT	11 R	12 R

v (vph)	9	2	26	9	8	13
C(m) (vph)	700	352	77	359	154	594
v/c	0.01	0.01	0.34	0.03	0.05	0.02
95% queue length	0.04	0.02	1.27	0.08	0.16	0.07
Control Delay	10.2	15.3	73.9	15.3	29.7	11.2
LOS	B	C	F	C	D	B
Approach Delay	58.9			18.2		
Approach LOS	F			C		

TWO-WAY STOP CONTROL SUMMARY

Analyst: AG  
 Agency/Co.: American  
 Date Performed: 06/17/2013  
 Analysis Time Period: AM Peak  
 Intersection: Ohio Street & US 41  
 Jurisdiction: FDOT D7  
 Units: U. S. Customary  
 Analysis Year: 2040 Build  
 Project ID: US 41 PD&E Study  
 East/West Street: Ohio St  
 North/South Street: US 41  
 Intersection Orientation: NS  
 Study period (hrs): 0.25

Vehicle Volumes and Adjustments

Major Street:	Approach Movement	Northbound			Southbound		
		1 L	2 T	3 R	4 L	5 T	6 R

Volume		1608	23		79	779	
Peak-Hour Factor, PHF		0.95	0.95		0.95	0.95	
Hourly Flow Rate, HFR		1692	24		83	820	
Percent Heavy Vehicles		--	--		5	--	--
Median Type/Storage		Raised curb			/ 1		
RT Channelized?							
Lanes		2	0		1	2	
Configuration		T	TR		L	T	
Upstream Signal?		No			No		

Minor Street:	Approach Movement	Westbound			Eastbound		
		7 L	8 T	9 R	10 L	11 T	12 R

Volume		43		43			
Peak Hour Factor, PHF		0.95		0.95			
Hourly Flow Rate, HFR		45		45			
Percent Heavy Vehicles		16		16			
Percent Grade (%)			0			0	
Flared Approach: Exists?/Storage					/		/
Lanes		1		1			
Configuration		L		R			

Delay, Queue Length, and Level of Service

Approach	NB	SB	Westbound			Eastbound		
			1	4	7	8	9	10

Movement								
Lane Config		L		L		R		
v (vph)		83		45		45		
C(m) (vph)		352		86		323		
v/c		0.24		0.52		0.14		
95% queue length		0.90		2.28		0.48		
Control Delay		18.4		85.8		17.9		
LOS		C		F		C		
Approach Delay					51.8			
Approach LOS					F			



## TWO-WAY STOP CONTROL SUMMARY

Analyst: AG  
 Agency/Co.: American  
 Date Performed: 06/17/2013  
 Analysis Time Period: AM Peak  
 Intersection: Florence St & US 41  
 Jurisdiction: FDOT D7  
 Units: U. S. Customary  
 Analysis Year: 2040 Build  
 Project ID: US 41 PD&E Study  
 East/West Street: Florence St  
 North/South Street: US 41  
 Intersection Orientation: NS Study period (hrs): 0.25

## Vehicle Volumes and Adjustments

Major Street:	Approach Movement	Northbound			Southbound		
		1 L	2 T	3 R	4 L	5 T	6 R

Volume	8	1491	0	4	819	22	
Peak-Hour Factor, PHF	0.95	0.95	0.95	0.95	0.95	0.95	
Hourly Flow Rate, HFR	8	1569	0	4	862	23	
Percent Heavy Vehicles	5	--	--	5	--	--	
Median Type/Storage	Raised curb			/ 1			
RT Channelized?							
Lanes		1	2	0	1	2	0
Configuration		L	T	TR	L	T	TR
Upstream Signal?		No			No		

Minor Street:	Approach Movement	Westbound			Eastbound		
		7 L	8 T	9 R	10 L	11 T	12 R

Volume	9	0	17	17	0	11	
Peak Hour Factor, PHF	0.95	0.95	0.95	0.95	0.95	0.95	
Hourly Flow Rate, HFR	9	0	17	17	0	11	
Percent Heavy Vehicles	0	0	0	0	0	0	
Percent Grade (%)		0			0		
Flared Approach: Exists?/Storage		No		/	No		/
Lanes		0	1	0	0	1	0
Configuration		LTR			LTR		

## Delay, Queue Length, and Level of Service

Approach	NB	SB	Westbound			Eastbound		
			7	8	9	10	11	12

Movement	1	4						
Lane Config	L	L		LTR			LTR	
v (vph)	8	4		26			28	
C(m) (vph)	742	403		187			240	
v/c	0.01	0.01		0.14			0.12	
95% queue length	0.03	0.03		0.47			0.39	
Control Delay	9.9	14.0		27.3			22.0	
LOS	A	B		D			C	
Approach Delay				27.3			22.0	
Approach LOS				D			C	

# HCM Signalized Intersection Capacity Analysis

## 35: Symmes Rd & US 41

7/23/2013



Movement	EBL	EBT	EBR	WBL	WBT	WBR	NBL	NBT	NBR	SBL	SBT	SBR
Lane Configurations		↕		↙↘	↕	↗	↙	↑↑↑	↗	↙↘	↑↑↑	
Volume (vph)	1	0	0	311	0	728	17	2019	218	211	1236	0
Ideal Flow (vphpl)	1900	1900	1900	1900	1900	1900	1900	1900	1900	1900	1900	1900
Total Lost time (s)		7.2		7.2	7.2	7.2	6.2	6.2	7.2	7.0	6.2	
Lane Util. Factor		1.00		0.97	0.95	0.95	1.00	0.91	1.00	0.97	0.91	
Fr't		1.00		1.00	0.85	0.85	1.00	1.00	0.85	1.00	1.00	
Flt Protected		0.95		0.95	1.00	1.00	0.95	1.00	1.00	0.95	1.00	
Satd. Flow (prot)		1805		3303	1447	1447	1719	4940	1538	3335	4940	
Flt Permitted		1.00		0.95	1.00	1.00	0.95	1.00	1.00	0.95	1.00	
Satd. Flow (perm)		1900		3303	1447	1447	1719	4940	1538	3335	4940	
Peak-hour factor, PHF	0.95	0.95	0.95	0.95	0.95	0.95	0.95	0.95	0.95	0.95	0.95	0.95
Adj. Flow (vph)	1	0	0	327	0	766	18	2125	229	222	1301	0
RTOR Reduction (vph)	0	0	0	0	0	0	0	0	81	0	0	0
Lane Group Flow (vph)	0	1	0	327	383	383	18	2125	148	222	1301	0
Heavy Vehicles (%)	0%	0%	0%	6%	6%	6%	5%	5%	5%	5%	5%	5%
Turn Type	Perm			Prot		pt+ov	Prot		pm+ov	Prot		
Protected Phases		8		7	4	4 5	1	6	7	5	2	
Permitted Phases	8							6				
Actuated Green, G (s)		1.4		20.9	29.5	42.7	1.6	43.5	64.4	6.0	48.7	
Effective Green, g (s)		1.4		20.9	29.5	42.7	1.6	43.5	64.4	6.0	48.7	
Actuated g/C Ratio		0.01		0.21	0.30	0.43	0.02	0.44	0.65	0.06	0.49	
Clearance Time (s)		7.2		7.2	7.2		6.2	6.2	7.2	7.0	6.2	
Vehicle Extension (s)		3.0		3.0	3.0		3.0	4.0	3.0	3.0	4.0	
Lane Grp Cap (vph)		27		694	429	622	28	2162	996	201	2420	
v/s Ratio Prot				0.10	c0.26	c0.26	0.01	c0.43	0.03	c0.07	c0.26	
v/s Ratio Perm		0.00							0.07			
v/c Ratio		0.04		0.47	0.89	0.62	0.64	0.98	0.15	1.10	0.54	
Uniform Delay, d1		48.3		34.4	33.4	22.0	48.6	27.6	6.8	46.7	17.6	
Progression Factor		1.00		1.00	1.00	1.00	1.00	1.00	1.00	1.00	1.00	
Incremental Delay, d2		0.6		0.5	20.3	1.8	40.9	15.5	0.1	94.2	0.3	
Delay (s)		48.9		34.9	53.7	23.8	89.6	43.0	6.9	140.9	17.8	
Level of Service		D		C	D	C	F	D	A	F	B	
Approach Delay (s)		48.9			37.6			39.9			35.8	
Approach LOS		D			D			D			D	

### Intersection Summary

HCM Average Control Delay	38.1	HCM Level of Service	D
HCM Volume to Capacity ratio	1.07		
Actuated Cycle Length (s)	99.4	Sum of lost time (s)	26.6
Intersection Capacity Utilization	92.1%	ICU Level of Service	F
Analysis Period (min)	15		

c Critical Lane Group

# HCM Signalized Intersection Capacity Analysis

46: Palm Ave. & US 41

7/23/2013



Movement	EBL	EBT	EBR	WBL	WBT	WBR	NBL	NBT	NBR	SBL	SBT	SBR
Lane Configurations	↔			↖	↗		↖	↑↑↑		↖	↑↑↑	
Volume (vph)	49	0	22	4	0	29	5	2589	9	41	1391	7
Ideal Flow (vphpl)	1900	1900	1900	1900	1900	1900	1900	1900	1900	1900	1900	1900
Total Lost time (s)	6.7			6.7	6.7		6.2	6.2		6.5	6.2	
Lane Util. Factor	1.00			1.00	1.00		1.00	0.91		1.00	0.91	
Fr <sub>t</sub>	0.96			1.00	0.85		1.00	1.00		1.00	1.00	
Fl <sub>t</sub> Protected	0.97			0.95	1.00		0.95	1.00		0.95	1.00	
Satd. Flow (prot)	1760			1805	1615		1719	4938		1719	4936	
Fl <sub>t</sub> Permitted	0.77			0.71	1.00		0.95	1.00		0.95	1.00	
Satd. Flow (perm)	1409			1346	1615		1719	4938		1719	4936	
Peak-hour factor, PHF	0.95	0.95	0.95	0.95	0.95	0.95	0.95	0.95	0.95	0.95	0.95	0.95
Adj. Flow (vph)	52	0	23	4	0	31	5	2725	9	43	1464	7
RTOR Reduction (vph)	0	0	0	0	0	0	0	0	0	0	0	0
Lane Group Flow (vph)	0	75	0	4	31	0	5	2734	0	43	1471	0
Heavy Vehicles (%)	0%	0%	0%	0%	0%	0%	5%	5%	5%	5%	5%	5%
Turn Type	Perm			Perm			Prot			Prot		
Protected Phases	8			4			1 6			5 2		
Permitted Phases	8			4								
Actuated Green, G (s)	9.8			9.8 9.8			5.4 50.1			2.8 47.8		
Effective Green, g (s)	9.8			9.8 9.8			5.4 50.1			2.8 47.8		
Actuated g/C Ratio	0.12			0.12 0.12			0.07 0.61			0.03 0.58		
Clearance Time (s)	6.7			6.7 6.7			6.2 6.2			6.5 6.2		
Vehicle Extension (s)	3.0			3.0 3.0			4.0 4.0			2.5 4.0		
Lane Grp Cap (vph)	168			161 193			113 3013			59 2874		
v/s Ratio Prot				0.02			0.00 c0.55			c0.03 0.30		
v/s Ratio Perm	c0.05			0.00								
v/c Ratio	0.45			0.02 0.16			0.04 0.91			0.73 0.51		
Uniform Delay, d <sub>1</sub>	33.6			31.9 32.5			35.9 14.0			39.3 10.2		
Progression Factor	1.00			1.00 1.00			1.00 1.00			1.00 1.00		
Incremental Delay, d <sub>2</sub>	1.9			0.1 0.4			0.2 4.5			34.1 0.2		
Delay (s)	35.5			32.0 32.8			36.2 18.5			73.4 10.4		
Level of Service	D			C C			D B			E B		
Approach Delay (s)	35.5			32.8			18.5			12.2		
Approach LOS	D			C			B			B		

## Intersection Summary

HCM Average Control Delay	16.7	HCM Level of Service	B
HCM Volume to Capacity ratio	0.75		
Actuated Cycle Length (s)	82.1	Sum of lost time (s)	13.2
Intersection Capacity Utilization	71.7%	ICU Level of Service	C
Analysis Period (min)	15		

c Critical Lane Group

TWO-WAY STOP CONTROL SUMMARY

Analyst: AG  
 Agency/Co.: American  
 Date Performed: 06/17/2013  
 Analysis Time Period: AM Peak  
 Intersection: Nundy Ave & US 41  
 Jurisdiction: FDOT D7  
 Units: U. S. Customary  
 Analysis Year: 2040 Build  
 Project ID: US 41 PD&E Study  
 East/West Street: Nundy Ave  
 North/South Street: US 41  
 Intersection Orientation: NS Study period (hrs): 0.25

Vehicle Volumes and Adjustments

Major Street:	Approach Movement	Northbound			Southbound		
		1 L	2 T	3 R	4 L	5 T	6 R
Volume		16	1697	27	41	938	5
Peak-Hour Factor, PHF		0.95	0.95	0.95	0.95	0.95	0.95
Hourly Flow Rate, HFR		16	1786	28	43	987	5
Percent Heavy Vehicles		5	--	--	5	--	--
Median Type/Storage		Raised curb			/ 1		
RT Channelized?							
Lanes		1	2	0	1	2	0
Configuration		L	T	TR	L	T	TR
Upstream Signal?		No			Yes		

Minor Street:	Approach Movement	Westbound			Eastbound		
		7 L	8 T	9 R	10 L	11 T	12 R
Volume		75	0	115	3	6	14
Peak Hour Factor, PHF		0.95	0.95	0.95	0.95	0.95	0.95
Hourly Flow Rate, HFR		78	0	121	3	6	14
Percent Heavy Vehicles		10	10	10	0	0	0
Percent Grade (%)		0			0		
Flared Approach: Exists?/Storage					/ No /		
Lanes		0	1	1	0	1	0
Configuration		LT		R	LTR		

Delay, Queue Length, and Level of Service

Approach	NB	SB	Westbound			Eastbound		
			7 LT	8	9 R	10	11 LTR	12
Movement	1	4	7	8	9	10	11	12
Lane Config	L	L	LT		R		LTR	
v (vph)	16	43	78		121		23	
C(m) (vph)	993	322	60		314		163	
v/c	0.02	0.13	1.30		0.39		0.14	
95% queue length	0.05	0.46	6.65		1.75		0.48	
Control Delay	8.7	17.9	331.6		23.5		30.7	
LOS	A	C	F		C		D	
Approach Delay				144.3			30.7	
Approach LOS				F			D	

# HCM Signalized Intersection Capacity Analysis

## 40: Alice Ave & US 41

7/23/2013



Movement	EBL	EBT	EBR	WBL	WBT	WBR	NBL	NBT	NBR	SBL	SBT	SBR
Lane Configurations		↕		↕↕↕	↑	↕↕	↕	↕↕↕	↕	↕↕↕	↕↕↕	↕↕↕
Volume (vph)	21	38	9	499	99	771	17	2281	318	358	1341	26
Ideal Flow (vphpl)	1900	1900	1900	1900	1900	1900	1900	1900	1900	1900	1900	1900
Total Lost time (s)		9.0		9.0	9.0	9.0	6.1	6.1	6.1	6.7	6.1	
Lane Util. Factor		1.00		0.94	1.00	0.88	1.00	0.91	1.00	0.94	0.91	
Fr't		0.98		1.00	1.00	0.85	1.00	1.00	0.85	1.00	1.00	
Flt Protected		0.98		0.95	1.00	1.00	0.95	1.00	1.00	0.95	1.00	
Satd. Flow (prot)		1839		4802	1792	2682	1719	4940	1538	4848	4926	
Flt Permitted		0.86		0.95	1.00	1.00	0.95	1.00	1.00	0.95	1.00	
Satd. Flow (perm)		1601		4802	1792	2682	1719	4940	1538	4848	4926	
Peak-hour factor, PHF	0.95	0.95	0.95	0.95	0.95	0.95	0.95	0.95	0.95	0.95	0.95	0.95
Adj. Flow (vph)	22	40	9	525	104	812	18	2401	335	377	1412	27
RTOR Reduction (vph)	0	0	0	0	0	0	0	0	0	0	0	0
Lane Group Flow (vph)	0	71	0	525	104	812	18	2401	335	377	1439	0
Heavy Vehicles (%)	0%	0%	0%	6%	6%	6%	5%	5%	5%	5%	5%	5%
Turn Type	Perm			Prot		pt+ov	Prot		pt+ov	Prot		
Protected Phases		8		7	4	4 5	1	6	6 7	5	2	
Permitted Phases	8											
Actuated Green, G (s)		16.0		15.0	40.0	60.3	2.3	70.5	91.6	11.3	80.1	
Effective Green, g (s)		16.0		15.0	40.0	60.3	2.3	70.5	91.6	11.3	80.1	
Actuated g/C Ratio		0.11		0.10	0.28	0.42	0.02	0.49	0.64	0.08	0.56	
Clearance Time (s)		9.0		9.0	9.0		6.1	6.1		6.7	6.1	
Vehicle Extension (s)		3.0		3.0	6.0		3.0	8.0		3.0	8.0	
Lane Grp Cap (vph)		178		502	499	1126	28	2425	981	381	2748	
v/s Ratio Prot				c0.11	0.06	c0.30	0.01	c0.49	0.22	c0.08	0.29	
v/s Ratio Perm		0.04										
v/c Ratio		0.40		1.05	0.21	0.72	0.64	0.99	0.34	0.99	0.52	
Uniform Delay, d1		59.3		64.3	39.7	34.7	70.2	36.2	12.0	66.1	19.8	
Progression Factor		1.00		1.00	1.00	1.00	1.00	1.00	1.00	1.00	1.00	
Incremental Delay, d2		6.6		52.7	0.9	4.0	40.9	16.1	0.2	43.6	0.7	
Delay (s)		65.9		117.0	40.6	38.7	111.2	52.3	12.2	109.7	20.6	
Level of Service		E		F	D	D	F	D	B	F	C	
Approach Delay (s)		65.9			67.3			47.8			39.0	
Approach LOS		E			E			D			D	

### Intersection Summary

HCM Average Control Delay	50.0	HCM Level of Service	D
HCM Volume to Capacity ratio	0.89		
Actuated Cycle Length (s)	143.6	Sum of lost time (s)	15.1
Intersection Capacity Utilization	97.0%	ICU Level of Service	F
Analysis Period (min)	15		

c Critical Lane Group

# HCM Signalized Intersection Capacity Analysis

## 9: Industrial Access Rd & US 41

7/23/2013



Movement	EBL	EBT	EBR	WBL	WBT	WBR	NBL	NBT	NBR	SBL	SBT	SBR
Lane Configurations	↖	↑	↗	↖↗	↑	↗	↖	↑↑↑	↗	↖	↑↑↑	↗
Volume (vph)	11	16	24	589	65	402	98	2714	291	28	1441	49
Ideal Flow (vphpl)	1900	1900	1900	1900	1900	1900	1900	1900	1900	1900	1900	1900
Total Lost time (s)	6.3	6.3	6.4	6.3	6.3	6.3	6.4	6.4	6.3	6.4	6.4	6.4
Lane Util. Factor	1.00	1.00	1.00	0.94	1.00	1.00	1.00	0.91	1.00	1.00	0.91	1.00
Fr <sub>t</sub>	1.00	1.00	0.85	1.00	1.00	0.85	1.00	1.00	0.85	1.00	1.00	0.85
Fit Protected	0.95	1.00	1.00	0.95	1.00	1.00	0.95	1.00	1.00	0.95	1.00	1.00
Satd. Flow (prot)	1583	1667	1417	4802	1792	1524	1719	4940	1538	1719	4940	1538
Fit Permitted	0.71	1.00	1.00	0.95	1.00	1.00	0.95	1.00	1.00	0.95	1.00	1.00
Satd. Flow (perm)	1188	1667	1417	4802	1792	1524	1719	4940	1538	1719	4940	1538
Peak-hour factor, PHF	0.95	0.95	0.95	0.95	0.95	0.95	0.95	0.95	0.95	0.95	0.95	0.95
Adj. Flow (vph)	12	17	25	620	68	423	103	2857	306	29	1517	52
RTOR Reduction (vph)	0	0	10	0	0	0	0	0	73	0	0	0
Lane Group Flow (vph)	12	17	15	620	68	423	103	2857	233	29	1517	52
Heavy Vehicles (%)	14%	14%	14%	6%	6%	6%	5%	5%	5%	5%	5%	5%
Turn Type	Perm		pm+ov	Prot		Prot	Prot		pm+ov	Prot		Prot
Protected Phases		8	1	7	4	4	1	6	7	5	2	2
Permitted Phases	8		8					6				
Actuated Green, G (s)	9.5	9.5	23.1	28.6	44.4	44.4	13.6	85.6	114.2	3.2	75.2	75.2
Effective Green, g (s)	9.5	9.5	23.1	28.6	44.4	44.4	13.6	85.6	114.2	3.2	75.2	75.2
Actuated g/C Ratio	0.06	0.06	0.15	0.19	0.29	0.29	0.09	0.56	0.75	0.02	0.49	0.49
Clearance Time (s)	6.3	6.3	6.4	6.3	6.3	6.3	6.4	6.4	6.3	6.4	6.4	6.4
Vehicle Extension (s)	6.0	6.0	3.0	3.0	6.0	6.0	3.0	8.0	3.0	3.0	8.0	8.0
Lane Grp Cap (vph)	74	104	215	902	522	444	154	2777	1153	36	2439	759
v/s Ratio Prot		0.01	0.01	0.13	0.04	c0.28	c0.06	c0.58	0.04	0.02	0.31	0.03
v/s Ratio Perm	0.01		0.00						0.11			
v/c Ratio	0.16	0.16	0.07	0.69	0.13	0.95	0.67	1.03	0.20	0.81	0.62	0.07
Uniform Delay, d1	67.6	67.6	55.4	57.7	39.7	52.9	67.2	33.4	5.6	74.2	28.2	20.2
Progression Factor	1.00	1.00	1.00	1.00	1.00	1.00	1.00	1.00	1.00	1.00	1.00	1.00
Incremental Delay, d2	2.9	2.1	0.1	2.2	0.3	31.8	10.5	25.0	0.1	75.6	1.2	0.2
Delay (s)	70.5	69.7	55.5	59.9	40.1	84.7	77.7	58.3	5.7	149.8	29.4	20.4
Level of Service	E	E	E	E	D	F	E	E	A	F	C	C
Approach Delay (s)		63.3			68.1			54.0			31.3	
Approach LOS		E			E			D			C	

Intersection Summary			
HCM Average Control Delay	50.7	HCM Level of Service	D
HCM Volume to Capacity ratio	1.01		
Actuated Cycle Length (s)	152.3	Sum of lost time (s)	19.1
Intersection Capacity Utilization	99.0%	ICU Level of Service	F
Analysis Period (min)	15		
c Critical Lane Group			

HCM Signalized Intersection Capacity Analysis  
 10: Pendola Point Rd & US 41

7/23/2013



Movement	EBL	EBT	EBR	WBL	WBT	WBR	NBL	NBT	NBR	SBL	SBT	SBR
Lane Configurations												
Volume (vph)	65	11	26	133	32	921	20	2628	82	485	1279	89
Ideal Flow (vphpl)	1900	1900	1900	1900	1900	1900	1900	1900	1900	1900	1900	1900
Total Lost time (s)	8.1	8.1		7.1	7.1	7.1	7.5	7.5	7.5	7.5	7.5	7.5
Lane Util. Factor	1.00	1.00		1.00	1.00	0.76	1.00	0.91	1.00	0.94	0.91	1.00
Fr <sub>t</sub>	1.00	0.90		1.00	1.00	0.85	1.00	1.00	0.85	1.00	1.00	0.85
Fit Protected	0.95	1.00		0.95	1.00	1.00	0.95	1.00	1.00	0.95	1.00	1.00
Satd. Flow (prot)	1157	1091		1641	1727	3347	1719	4940	1538	4848	4940	1538
Fit Permitted	0.73	1.00		0.55	1.00	1.00	0.95	1.00	1.00	0.95	1.00	1.00
Satd. Flow (perm)	895	1091		943	1727	3347	1719	4940	1538	4848	4940	1538
Peak-hour factor, PHF	0.95	0.95	0.95	0.95	0.95	0.95	0.95	0.95	0.95	0.95	0.95	0.95
Adj. Flow (vph)	68	12	27	140	34	969	21	2766	86	511	1346	94
RTOR Reduction (vph)	0	25	0	0	0	41	0	0	19	0	0	35
Lane Group Flow (vph)	68	14	0	140	34	928	21	2766	67	511	1346	59
Heavy Vehicles (%)	56%	56%	56%	10%	10%	10%	5%	5%	5%	5%	5%	5%
Turn Type	pm+pt			pm+pt		pt+ov	Prot		Perm	Prot		Perm
Protected Phases	3	8		7	4	4 5	1	6		5		2
Permitted Phases	8			4					6			2
Actuated Green, G (s)	16.3	13.1		27.9	18.9	42.5	3.6	83.5	83.5	16.5	96.4	96.4
Effective Green, g (s)	16.3	13.1		27.9	18.9	42.5	3.6	83.5	83.5	16.5	96.4	96.4
Actuated g/C Ratio	0.11	0.09		0.18	0.12	0.28	0.02	0.55	0.55	0.11	0.63	0.63
Clearance Time (s)	8.1	8.1		7.1	7.1		7.5	7.5	7.5	7.5	7.5	7.5
Vehicle Extension (s)	3.0	6.0		3.0	6.0		3.0	8.0	8.0	6.0	8.0	8.0
Lane Grp Cap (vph)	101	94		214	214	934	41	2708	843	525	3127	973
v/s Ratio Prot	0.01	0.01		0.04	0.02	0.28	0.01	0.56		0.11	0.27	
v/s Ratio Perm	0.06			0.08					0.04			0.04
v/c Ratio	0.67	0.15		0.65	0.16	0.99	0.51	1.02	0.08	0.97	0.43	0.06
Uniform Delay, d1	65.0	64.5		56.7	59.6	54.8	73.5	34.4	16.3	67.7	14.1	10.7
Progression Factor	1.00	1.00		1.00	1.00	1.00	1.00	1.00	1.00	1.00	1.00	1.00
Incremental Delay, d2	16.3	2.1		7.0	1.0	27.8	10.4	23.0	0.2	32.9	0.4	0.1
Delay (s)	81.2	66.6		63.7	60.6	82.6	83.9	57.4	16.4	100.5	14.5	10.8
Level of Service	F	E		E	E	F	F	E	B	F	B	B
Approach Delay (s)		75.9			79.6			56.3			36.9	
Approach LOS		E			E			E			D	

Intersection Summary

HCM Average Control Delay	54.8	HCM Level of Service	D
HCM Volume to Capacity ratio	1.02		
Actuated Cycle Length (s)	152.3	Sum of lost time (s)	21.7
Intersection Capacity Utilization	94.8%	ICU Level of Service	F
Analysis Period (min)	15		

c Critical Lane Group

HCM Signalized Intersection Capacity Analysis  
 17: Port Sutton Rd & US 41

7/23/2013



Movement	EBL	EBR	NBL	NBT	SBU	SBT	SBR
Lane Configurations	↙	↘	↙	↑↑↑	↻	↑↑↑	↘
Volume (vph)	56	20	38	3295	10	1831	129
Ideal Flow (vphpl)	1900	1900	1900	1900	1900	1900	1900
Total Lost time (s)	7.7	7.0	7.0	6.7	6.4	6.7	7.7
Lane Util. Factor	1.00	1.00	1.00	0.91	1.00	0.91	1.00
Fr <sub>t</sub>	1.00	0.85	1.00	1.00	1.00	1.00	0.85
Fl <sub>t</sub> Protected	0.95	1.00	0.95	1.00	0.95	1.00	1.00
Satd. Flow (prot)	1271	1137	1719	4940	1719	4940	1538
Fl <sub>t</sub> Permitted	0.95	1.00	0.95	1.00	0.95	1.00	1.00
Satd. Flow (perm)	1271	1137	1719	4940	1719	4940	1538
Peak-hour factor, PHF	0.95	0.95	0.95	0.95	0.95	0.95	0.95
Adj. Flow (vph)	59	21	40	3468	11	1927	136
RTOR Reduction (vph)	0	18	0	0	0	0	27
Lane Group Flow (vph)	59	3	40	3468	11	1927	109
Heavy Vehicles (%)	42%	42%	5%	5%	5%	5%	5%
Turn Type		pm+ov	Prot		Prot		pm+ov
Protected Phases	8	1	6	5	2	8	
Permitted Phases		8				2	
Actuated Green, G (s)	13.6	20.2	6.6	102.5	1.9	97.2	110.8
Effective Green, g (s)	13.6	20.2	6.6	102.5	1.9	97.2	110.8
Actuated g/C Ratio	0.10	0.15	0.05	0.74	0.01	0.70	0.80
Clearance Time (s)	7.7	7.0	7.0	6.7	6.4	6.7	7.7
Vehicle Extension (s)	6.0	3.0	3.0	8.0	3.0	8.0	6.0
Lane Grp Cap (vph)	125	165	82	3648	24	3459	1228
v/s Ratio Prot	c0.05	0.00	c0.02	c0.70	0.01	0.39	0.01
v/s Ratio Perm		0.00					0.06
v/c Ratio	0.47	0.02	0.49	0.95	0.46	0.56	0.09
Uniform Delay, d <sub>1</sub>	59.2	50.8	64.5	15.9	67.9	10.2	3.0
Progression Factor	1.00	1.00	1.00	1.00	1.00	1.00	1.00
Incremental Delay, d <sub>2</sub>	7.7	0.0	4.5	7.2	13.2	0.7	0.1
Delay (s)	66.9	50.9	69.0	23.1	81.2	10.9	3.1
Level of Service	E	D	E	C	F	B	A
Approach Delay (s)	62.7			23.6		10.7	
Approach LOS	E			C		B	

**Intersection Summary**

HCM Average Control Delay	19.5	HCM Level of Service	B
HCM Volume to Capacity ratio	0.91		
Actuated Cycle Length (s)	138.8	Sum of lost time (s)	21.4
Intersection Capacity Utilization	81.5%	ICU Level of Service	D
Analysis Period (min)	15		

c Critical Lane Group





Arterial Level of Service: NB US 41

Cross Street	Arterial Class	Flow Speed	Running Time	Signal Delay	Travel Time (s)	Dist (mi)	Arterial Speed	Arterial LOS
Symmes Rd	II	45	162.3	39.2	201.5	2.03	36.2	A
Palm Ave.	II	40	40.6	18.5	59.1	0.42	25.7	C
Gibsonton Dr	II	40	52.7	59.1	111.8	0.59	18.9	D
Riverview Dr	II	40	93.1	48.8	141.9	1.03	26.3	C
CR 676A (Madison Ave	II	45	222.0	58.3	280.3	2.77	35.6	A
Port Sutton Rd	II	45	34.3	20.0	54.3	0.36	23.7	C
<b>Total</b>	<b>II</b>		<b>605.0</b>	<b>243.9</b>	<b>848.9</b>	<b>7.20</b>	<b>30.5</b>	<b>B</b>

Arterial Level of Service: SB US 41

Cross Street	Arterial Class	Flow Speed	Running Time	Signal Delay	Travel Time (s)	Dist (mi)	Arterial Speed	Arterial LOS
Port Sutton Rd	II	45	92.6	11.4	104.0	1.16	40.0	A
Pendola Point Rd	II	45	34.3	13.8	48.1	0.36	26.7	C
Industrial Access Rd	II	45	222.0	28.7	250.7	2.77	39.8	A
Alice Ave	II	40	93.1	19.6	112.7	1.03	33.1	B
Palm Ave.	II	40	52.7	11.6	64.3	0.59	32.8	B
Symmes Rd	II	40	40.6	14.4	55.0	0.42	27.7	C
<b>Total</b>	<b>II</b>		<b>535.3</b>	<b>99.5</b>	<b>634.8</b>	<b>6.33</b>	<b>35.9</b>	<b>A</b>

TWO-WAY STOP CONTROL SUMMARY

Analyst: AG  
 Agency/Co.: American  
 Date Performed: 06/17/2013  
 Analysis Time Period: PM Peak  
 Intersection: Kracker Avenue & US 41  
 Jurisdiction: FDOT D7  
 Units: U. S. Customary  
 Analysis Year: 2040 Build  
 Project ID: US 41 PD&E Study  
 East/West Street: Kracker Ave  
 North/South Street: US 41  
 Intersection Orientation: NS  
 Study period (hrs): 0.25

Vehicle Volumes and Adjustments

Major Street:	Approach Movement	Northbound			Southbound		
		1 L	2 T	3 R	4 L	5 T	6 R

Volume	10	893	14	7	1615	5
Peak-Hour Factor, PHF	0.95	0.95	0.95	0.95	0.95	0.95
Hourly Flow Rate, HFR	10	940	14	7	1700	5
Percent Heavy Vehicles	5	--	--	5	--	--
Median Type/Storage	Raised curb			/ 1		
RT Channelized?						
Lanes	1	2	0	1	2	0
Configuration	L	T	TR	L	T	TR
Upstream Signal?		No			No	

Minor Street:	Approach Movement	Westbound			Eastbound		
		7 L	8 T	9 R	10 L	11 T	12 R

Volume	14	2	14	6	0	6
Peak Hour Factor, PHF	0.95	0.95	0.95	0.95	0.95	0.95
Hourly Flow Rate, HFR	14	2	14	6	0	6
Percent Heavy Vehicles	15	15	15	0	0	0
Percent Grade (%)		0			0	
Flared Approach: Exists?/Storage				/		/
Lanes	0	1	1	0	1	1
Configuration		LT	R		LT	R

Delay, Queue Length, and Level of Service

Approach Movement	NB	SB	Westbound			Eastbound		
	1 L	4 L	7 LT	8 R	9 R	10 LT	11 R	12 R

v (vph)	10	7	16	14	6	6
C(m) (vph)	356	698	125	549	77	362
v/c	0.03	0.01	0.13	0.03	0.08	0.02
95% queue length	0.09	0.03	0.43	0.08	0.25	0.05
Control Delay	15.4	10.2	38.0	11.7	55.7	15.1
LOS	C	B	E	B	F	C
Approach Delay				25.7		35.4
Approach LOS				D		E

## TWO-WAY STOP CONTROL SUMMARY

Analyst: AG  
 Agency/Co.: American  
 Date Performed: 06/17/2013  
 Analysis Time Period: PM Peak  
 Intersection: Ohio Street & US 41  
 Jurisdiction: FDOT D7  
 Units: U. S. Customary  
 Analysis Year: 2040 Build  
 Project ID: US 41 PD&E Study  
 East/West Street: Ohio Street  
 North/South Street: US 41  
 Intersection Orientation: NS

Study period (hrs): 0.25

## Vehicle Volumes and Adjustments

Major Street:	Approach Movement	Northbound			Southbound		
		1 L	2 T	3 R	4 L	5 T	6 R

Volume		889	20		113	1421	
Peak-Hour Factor, PHF		0.95	0.95		0.95	0.95	
Hourly Flow Rate, HFR		935	21		118	1495	
Percent Heavy Vehicles		--	--		5	--	--
Median Type/Storage		Raised curb			/ 1		
RT Channelized?							
Lanes		2	0		1	2	
Configuration		T	TR		L	T	
Upstream Signal?		No				No	

Minor Street:	Approach Movement	Westbound			Eastbound		
		7 L	8 T	9 R	10 L	11 T	12 R

Volume		25		45			
Peak Hour Factor, PHF		0.95		0.95			
Hourly Flow Rate, HFR		26		47			
Percent Heavy Vehicles		0		0			
Percent Grade (%)			0			0	
Flared Approach: Exists?/Storage					/		/
Lanes		1		1			
Configuration		L		R			

## Delay, Queue Length, and Level of Service

Approach	NB	SB	Westbound			Eastbound		
			7 L	8 L	9 R	10 L	11 T	12 R

v (vph)		118	26		47		
C(m) (vph)		697	161		591		
v/c		0.17	0.16		0.08		
95% queue length		0.61	0.56		0.26		
Control Delay		11.2	31.6		11.6		
LOS		B	D		B		
Approach Delay				18.7			
Approach LOS				C			

## TWO-WAY STOP CONTROL SUMMARY

Analyst: AG  
 Agency/Co.: American  
 Date Performed: 06/17/2013  
 Analysis Time Period: PM Peak  
 Intersection: Florence St & US 41  
 Jurisdiction: FDOT D7  
 Units: U. S. Customary  
 Analysis Year: 2040 Build  
 Project ID: US 41 PD&E Study  
 East/West Street: Florence Street  
 North/South Street: US 41  
 Intersection Orientation: NS

Study period (hrs): 0.25

## Vehicle Volumes and Adjustments

Major Street:	Approach Movement	Northbound			Southbound		
		1 L	2 T	3 R	4 L	5 T	6 R
Volume		13	822	2	7	1485	20
Peak-Hour Factor, PHF		0.95	0.95	0.95	0.95	0.95	0.95
Hourly Flow Rate, HFR		13	865	2	7	1563	21
Percent Heavy Vehicles		5	--	--	5	--	--
Median Type/Storage		Raised curb			/ 1		
RT Channelized?							
Lanes		1	2	0	1	2	0
Configuration		L	T	TR	L	T	TR
Upstream Signal?			No			No	

Minor Street:	Approach Movement	Westbound			Eastbound		
		7 L	8 T	9 R	10 L	11 T	12 R
Volume		5	0	15	24	0	10
Peak Hour Factor, PHF		0.95	0.95	0.95	0.95	0.95	0.95
Hourly Flow Rate, HFR		5	0	15	25	0	10
Percent Heavy Vehicles		0	0	0	0	0	0
Percent Grade (%)			0			0	
Flared Approach: Exists?/Storage				No	/		No /
Lanes		0	1	0	0	1	0
Configuration			LTR			LTR	

## Delay, Queue Length, and Level of Service

Approach	NB	SB	Westbound			Eastbound		
			7	8	9	10	11	12
Movement	1	4	7	8	9	10	11	12
Lane Config	L	L		LTR			LTR	
v (vph)	13	7		20			35	
C(m) (vph)	397	754		372			119	
v/c	0.03	0.01		0.05			0.29	
95% queue length	0.10	0.03		0.17			1.13	
Control Delay	14.4	9.8		15.2			47.4	
LOS	B	A		C			E	
Approach Delay				15.2			47.4	
Approach LOS				C			E	

HCM Signalized Intersection Capacity Analysis  
 35: Symmes Rd & US 41

7/23/2013



Movement	EBL	EBT	EBR	WBL	WBT	WBR	NBL	NBT	NBR	SBL	SBT	SBR
Lane Configurations		↕		↙↘	↘	↙	↙	↕↕↕	↙	↙↘	↕↕↕	
Volume (vph)	0	2	0	215	0	244	3	1115	134	535	2063	5
Ideal Flow (vphpl)	1900	1900	1900	1900	1900	1900	1900	1900	1900	1900	1900	1900
Total Lost time (s)		7.2		7.2	7.2	7.2	6.2	6.2	7.2	7.0	6.2	
Lane Util. Factor		1.00		0.97	0.95	0.95	1.00	0.91	1.00	0.97	0.91	
Fr <sub>t</sub>		1.00		1.00	0.85	0.85	1.00	1.00	0.85	1.00	1.00	
Fl <sub>t</sub> Protected		1.00		0.95	1.00	1.00	0.95	1.00	1.00	0.95	1.00	
Satd. Flow (prot)		1900		3367	1475	1475	1719	4940	1538	3335	4938	
Fl <sub>t</sub> Permitted		1.00		0.95	1.00	1.00	0.95	1.00	1.00	0.95	1.00	
Satd. Flow (perm)		1900		3367	1475	1475	1719	4940	1538	3335	4938	
Peak-hour factor, PHF	0.95	0.95	0.95	0.95	0.95	0.95	0.95	0.95	0.95	0.95	0.95	0.95
Adj. Flow (vph)	0	2	0	226	0	257	3	1174	141	563	2172	5
RTOR Reduction (vph)	0	0	0	0	0	0	0	0	74	0	0	0
Lane Group Flow (vph)	0	2	0	226	129	128	3	1174	67	563	2177	0
Heavy Vehicles (%)	0%	0%	0%	4%	4%	4%	5%	5%	5%	5%	5%	5%
Turn Type	Perm			Prot		pt+ov	Prot		pm+ov	Prot		
Protected Phases		8		7	4	4 5	1	6	7	5	2	
Permitted Phases	8							6				
Actuated Green, G (s)		1.2		10.4	18.8	42.6	0.7	30.2	40.6	16.6	46.9	
Effective Green, g (s)		1.2		10.4	18.8	42.6	0.7	30.2	40.6	16.6	46.9	
Actuated g/C Ratio		0.01		0.12	0.22	0.50	0.01	0.35	0.47	0.19	0.55	
Clearance Time (s)		7.2		7.2	7.2		6.2	6.2	7.2	7.0	6.2	
Vehicle Extension (s)		3.0		3.0	3.0		3.0	4.0	3.0	3.0	4.0	
Lane Grp Cap (vph)		27		407	322	731	14	1735	726	644	2693	
v/s Ratio Prot		0.00		0.07	c0.09	0.09	0.00	0.24	0.01	c0.17	c0.44	
v/s Ratio Perm									0.03			
v/c Ratio		0.07		0.56	0.40	0.18	0.21	0.68	0.09	0.87	0.81	
Uniform Delay, d <sub>1</sub>		41.9		35.6	28.8	12.0	42.4	23.7	12.5	33.7	15.9	
Progression Factor		1.00		1.00	1.00	1.00	1.00	1.00	1.00	1.00	1.00	
Incremental Delay, d <sub>2</sub>		1.2		1.6	0.8	0.1	7.6	1.2	0.1	12.6	2.0	
Delay (s)		43.0		37.3	29.6	12.1	49.9	24.9	12.6	46.3	17.9	
Level of Service		D		D	C	B	D	C	B	D	B	
Approach Delay (s)		43.0			28.5			23.6			23.7	
Approach LOS		D			C			C			C	

Intersection Summary	
HCM Average Control Delay	24.2
HCM Volume to Capacity ratio	0.75
Actuated Cycle Length (s)	86.0
Intersection Capacity Utilization	72.4%
Analysis Period (min)	15
HCM Level of Service	C
Sum of lost time (s)	20.4
ICU Level of Service	C

c Critical Lane Group

HCM Signalized Intersection Capacity Analysis  
46: Palm Ave. & US 41

7/23/2013



Movement	EBL	EBT	EBR	WBL	WBT	WBR	NBL	NBT	NBR	SBL	SBT	SBR
Lane Configurations		↔		↵	↶		↵	↑↑↑		↵	↑↑↑	
Volume (vph)	38	4	6	22	1	30	7	1426	15	66	2496	26
Ideal Flow (vphpl)	1900	1900	1900	1900	1900	1900	1900	1900	1900	1900	1900	1900
Total Lost time (s)		6.7		6.7	6.7		6.2	6.2		6.5	6.2	
Lane Util. Factor		1.00		1.00	1.00		1.00	0.91		1.00	0.91	
Frt		0.98		1.00	0.85		1.00	1.00		1.00	1.00	
Flt Protected		0.96		0.95	1.00		0.95	1.00		0.95	1.00	
Satd. Flow (prot)		1728		1805	1624		1719	4932		1719	4932	
Flt Permitted		0.75		0.72	1.00		0.95	1.00		0.95	1.00	
Satd. Flow (perm)		1342		1376	1624		1719	4932		1719	4932	
Peak-hour factor, PHF	0.95	0.95	0.95	0.95	0.95	0.95	0.95	0.95	0.95	0.95	0.95	0.95
Adj. Flow (vph)	40	4	6	23	1	32	7	1501	16	69	2627	27
RTOR Reduction (vph)	0	0	0	0	0	0	0	0	0	0	0	0
Lane Group Flow (vph)	0	50	0	23	33	0	7	1517	0	69	2654	0
Heavy Vehicles (%)	4%	4%	4%	0%	0%	0%	5%	5%	5%	5%	5%	5%
Turn Type	Perm			Perm			Prot			Prot		
Protected Phases		8			4		1	6		5	2	
Permitted Phases	8			4								
Actuated Green, G (s)		8.8		8.8	8.8		5.3	49.3		6.6	50.9	
Effective Green, g (s)		8.8		8.8	8.8		5.3	49.3		6.6	50.9	
Actuated g/C Ratio		0.10		0.10	0.10		0.06	0.59		0.08	0.61	
Clearance Time (s)		6.7		6.7	6.7		6.2	6.2		6.5	6.2	
Vehicle Extension (s)		3.0		3.0	3.0		4.0	4.0		2.5	4.0	
Lane Grp Cap (vph)		140		144	170		108	2891		135	2985	
v/s Ratio Prot					0.02		0.00	0.31		c0.04	c0.54	
v/s Ratio Perm		c0.04		0.02								
v/c Ratio		0.36		0.16	0.19		0.06	0.52		0.51	0.89	
Uniform Delay, d1		35.0		34.3	34.4		37.1	10.4		37.2	14.2	
Progression Factor		1.00		1.00	1.00		1.00	1.00		1.00	1.00	
Incremental Delay, d2		1.6		0.5	0.6		0.3	0.2		2.4	3.7	
Delay (s)		36.6		34.8	35.0		37.4	10.6		39.6	17.9	
Level of Service		D		C	C		D	B		D	B	
Approach Delay (s)		36.6			34.9			10.7			18.5	
Approach LOS		D			C			B			B	

Intersection Summary

HCM Average Control Delay	16.2	HCM Level of Service	B
HCM Volume to Capacity ratio	0.73		
Actuated Cycle Length (s)	84.1	Sum of lost time (s)	13.2
Intersection Capacity Utilization	74.9%	ICU Level of Service	D
Analysis Period (min)	15		

c Critical Lane Group

TWO-WAY STOP CONTROL SUMMARY

Analyst: AG  
 Agency/Co.: American  
 Date Performed: 06/17/2013  
 Analysis Time Period: PM Peak  
 Intersection: Nundy Ave & US 41  
 Jurisdiction: FDOT D7  
 Units: U. S. Customary  
 Analysis Year: 2040 Build  
 Project ID: US 41 PD&E Study  
 East/West Street: Nundy Ave  
 North/South Street: US 41  
 Intersection Orientation: NS  
 Study period (hrs): 0.25

Vehicle Volumes and Adjustments

Major Street: Approach Movement	Northbound			Southbound		
	1 L	2 T	3 R	4 L	5 T	6 R
Volume	16	897	78	72	1689	11
Peak-Hour Factor, PHF	0.95	0.95	0.95	0.95	0.95	0.95
Hourly Flow Rate, HFR	16	944	82	75	1777	11
Percent Heavy Vehicles	5	--	--	5	--	--
Median Type/Storage	Raised curb			/ 1		
RT Channelized?						
Lanes	1	2	0	1	2	0
Configuration	L	T	TR	L	T	TR
Upstream Signal?	No			Yes		

Minor Street: Approach Movement	Westbound			Eastbound		
	7 L	8 T	9 R	10 L	11 T	12 R
Volume	95	4	51	7	0	21
Peak Hour Factor, PHF	0.95	0.95	0.95	0.95	0.95	0.95
Hourly Flow Rate, HFR	100	4	53	7	0	22
Percent Heavy Vehicles	3	3	3	0	0	0
Percent Grade (%)	0			0		
Flared Approach: Exists?/Storage				/ No /		
Lanes	0	1	1	0	1	0
Configuration	LT		R		LTR	

Delay, Queue Length, and Level of Service

Approach Movement Lane Config	NB	SB	Westbound		Eastbound			
	1 L	4 L	7 LT	8 R	9 R	10 L	11 LTR	12
v (vph)	16	75	104		53		29	
C(m) (vph)	466	655	215		556		257	
v/c	0.03	0.11	0.48		0.10		0.11	
95% queue length	0.11	0.39	2.40		0.31		0.38	
Control Delay	13.0	11.2	36.5		12.2		20.8	
LOS	B	B	E		B		C	
Approach Delay				28.3			20.8	
Approach LOS				D			C	



# HCM Signalized Intersection Capacity Analysis

40: Alice Ave & US 41

7/23/2013



Movement	EBL	EBT	EBR	WBL	WBT	WBR	NBL	NBT	NBR	SBL	SBT	SBR
Lane Configurations		↕		↙↘	↑	↗↖	↘	↑↑↑	↗	↙↘	↑↑↑	
Volume (vph)	12	27	19	573	77	239	16	996	442	722	2356	25
Ideal Flow (vphpl)	1900	1900	1900	1900	1900	1900	1900	1900	1900	1900	1900	1900
Total Lost time (s)		9.0		9.0	9.0	9.0	6.1	6.1	6.1	6.7	6.1	
Lane Util. Factor		1.00		0.94	1.00	0.88	1.00	0.91	1.00	0.94	0.91	
Fr <sub>t</sub>		0.96		1.00	1.00	0.85	1.00	1.00	0.85	1.00	1.00	
Fl <sub>t</sub> Protected		0.99		0.95	1.00	1.00	0.95	1.00	1.00	0.95	1.00	
Satd. Flow (prot)		1695		4848	1810	2707	1719	4940	1538	4848	4932	
Fl <sub>t</sub> Permitted		0.91		0.95	1.00	1.00	0.95	1.00	1.00	0.95	1.00	
Satd. Flow (perm)		1551		4848	1810	2707	1719	4940	1538	4848	4932	
Peak-hour factor, PHF	0.95	0.95	0.95	0.95	0.95	0.95	0.95	0.95	0.95	0.95	0.95	0.95
Adj. Flow (vph)	13	28	20	603	81	252	17	1048	465	760	2480	26
RTOR Reduction (vph)	0	0	0	0	0	0	0	0	0	0	0	0
Lane Group Flow (vph)	0	61	0	603	81	252	17	1048	465	760	2506	0
Heavy Vehicles (%)	6%	6%	6%	5%	5%	5%	5%	5%	5%	5%	5%	5%
Turn Type	Perm			Prot		pt+ov	Prot		pt+ov	Prot		
Protected Phases		8		7	4	4 5	1	6	6 7	5	2	
Permitted Phases	8											
Actuated Green, G (s)		16.0		16.0	41.0	77.5	1.6	43.4	65.5	27.5	69.9	
Effective Green, g (s)		16.0		16.0	41.0	77.5	1.6	43.4	65.5	27.5	69.9	
Actuated g/C Ratio		0.12		0.12	0.31	0.58	0.01	0.32	0.49	0.21	0.52	
Clearance Time (s)		9.0		9.0	9.0		6.1	6.1		6.7	6.1	
Vehicle Extension (s)		3.0		3.0	6.0		3.0	8.0		3.0	8.0	
Lane Grp Cap (vph)		186		580	555	1569	21	1604	753	997	2579	
v/s Ratio Prot				c0.12	0.04	0.09	0.01	0.21	0.30	c0.16	c0.51	
v/s Ratio Perm		c0.04										
v/c Ratio		0.33		1.04	0.15	0.16	0.81	0.65	0.62	0.76	0.97	
Uniform Delay, d <sub>1</sub>		53.9		58.8	33.6	13.0	65.9	38.7	24.9	50.0	30.9	
Progression Factor		1.00		1.00	1.00	1.00	1.00	1.00	1.00	1.00	1.00	
Incremental Delay, d <sub>2</sub>		4.7		48.1	0.6	0.2	109.0	2.1	1.5	5.5	12.2	
Delay (s)		58.6		106.9	34.2	13.2	174.9	40.8	26.5	55.5	43.2	
Level of Service		E		F	C	B	F	D	C	E	D	
Approach Delay (s)		58.6			75.4			37.9			46.0	
Approach LOS		E			E			D			D	

Intersection Summary		
HCM Average Control Delay	48.8	HCM Level of Service
HCM Volume to Capacity ratio	0.91	D
Actuated Cycle Length (s)	133.7	Sum of lost time (s)
Intersection Capacity Utilization	84.6%	30.8
Analysis Period (min)	15	ICU Level of Service
		E

c Critical Lane Group

# HCM Signalized Intersection Capacity Analysis

## 9: Industrial Access Rd & US 41

7/23/2013



Movement	EBL	EBT	EBR	WBL	WBT	WBR	NBL	NBT	NBR	SBL	SBT	SBR
Lane Configurations	↙	↑	↗	↙↗	↑	↗	↙	↑↑↑	↗	↙	↑↑↑	↗
Volume (vph)	33	55	68	702	14	68	25	1213	488	164	2549	17
Ideal Flow (vphpl)	1900	1900	1900	1900	1900	1900	1900	1900	1900	1900	1900	1900
Total Lost time (s)	6.3	6.3	6.4	6.3	6.3	6.3	6.4	6.4	6.3	6.4	6.4	6.4
Lane Util. Factor	1.00	1.00	1.00	0.94	1.00	1.00	1.00	0.91	1.00	1.00	0.91	1.00
Fr <sub>t</sub>	1.00	1.00	0.85	1.00	1.00	0.85	1.00	1.00	0.85	1.00	1.00	0.85
Fl <sub>t</sub> Protected	0.95	1.00	1.00	0.95	1.00	1.00	0.95	1.00	1.00	0.95	1.00	1.00
Satd. Flow (prot)	1787	1881	1599	4990	1863	1583	1719	4940	1538	1719	4940	1538
Fl <sub>t</sub> Permitted	0.75	1.00	1.00	0.95	1.00	1.00	0.95	1.00	1.00	0.95	1.00	1.00
Satd. Flow (perm)	1407	1881	1599	4990	1863	1583	1719	4940	1538	1719	4940	1538
Peak-hour factor, PHF	0.95	0.95	0.95	0.95	0.95	0.95	0.95	0.95	0.95	0.95	0.95	0.95
Adj. Flow (vph)	35	58	72	739	15	72	26	1277	514	173	2683	18
RTOR Reduction (vph)	0	0	1	0	0	0	0	0	153	0	0	0
Lane Group Flow (vph)	35	58	71	739	15	72	26	1277	361	173	2683	18
Heavy Vehicles (%)	1%	1%	1%	2%	2%	2%	5%	5%	5%	5%	5%	5%
Turn Type	Perm		pm+ov	Prot		Prot	Prot		pm+ov	Prot		Prot
Protected Phases		8	1	7	4	4	1	6	7	5	2	2
Permitted Phases	8		8					6				
Actuated Green, G (s)	10.6	10.6	14.6	22.8	39.7	39.7	4.0	67.0	89.8	19.2	82.2	82.2
Effective Green, g (s)	10.6	10.6	14.6	22.8	39.7	39.7	4.0	67.0	89.8	19.2	82.2	82.2
Actuated g/C Ratio	0.07	0.07	0.10	0.16	0.27	0.27	0.03	0.46	0.62	0.13	0.57	0.57
Clearance Time (s)	6.3	6.3	6.4	6.3	6.3	6.3	6.4	6.4	6.3	6.4	6.4	6.4
Vehicle Extension (s)	6.0	6.0	3.0	3.0	6.0	6.0	3.0	8.0	3.0	3.0	8.0	8.0
Lane Grp Cap (vph)	103	138	161	785	510	433	47	2283	952	228	2800	872
v/s Ratio Prot		0.03	c0.01	c0.15	0.01	0.05	0.02	0.26	0.06	c0.10	c0.54	0.01
v/s Ratio Perm	0.02		0.03						0.18			
v/c Ratio	0.34	0.42	0.44	0.94	0.03	0.17	0.55	0.56	0.38	0.76	0.96	0.02
Uniform Delay, d <sub>1</sub>	63.9	64.3	61.4	60.4	38.5	40.1	69.6	28.3	13.7	60.7	29.8	13.8
Progression Factor	1.00	1.00	1.00	1.00	1.00	1.00	1.00	1.00	1.00	1.00	1.00	1.00
Incremental Delay, d <sub>2</sub>	5.5	5.7	1.9	19.2	0.1	0.5	13.3	1.0	0.3	13.5	9.7	0.0
Delay (s)	69.4	70.0	63.3	79.7	38.6	40.6	83.0	29.3	14.0	74.1	39.5	13.8
Level of Service	E	E	E	E	D	D	F	C	B	E	D	B
Approach Delay (s)		66.9			75.5			25.7			41.4	
Approach LOS		E			E			C			D	

### Intersection Summary

HCM Average Control Delay	42.1	HCM Level of Service	D
HCM Volume to Capacity ratio	0.93		
Actuated Cycle Length (s)	145.0	Sum of lost time (s)	25.5
Intersection Capacity Utilization	88.5%	ICU Level of Service	E
Analysis Period (min)	15		

c Critical Lane Group

# HCM Signalized Intersection Capacity Analysis

## 10: Pendola Point Rd & US 41

7/23/2013



Movement	EBL	EBT	EBR	WBL	WBT	WBR	NBL	NBT	NBR	SBL	SBT	SBR
Lane Configurations	↖	↗		↖	↑	↗↗↗	↖	↑↑↑	↗	↖↖↖	↑↑↑	↗
Volume (vph)	134	64	14	191	0	350	3	1441	75	647	2678	8
Ideal Flow (vphpl)	1900	1900	1900	1900	1900	1900	1900	1900	1900	1900	1900	1900
Total Lost time (s)	8.1	8.1		7.1		7.1	7.5	7.5	7.5	7.5	7.5	7.5
Lane Util. Factor	1.00	1.00		1.00		0.76	1.00	0.91	1.00	0.94	0.91	1.00
Frts	1.00	0.97		1.00		0.85	1.00	1.00	0.85	1.00	1.00	0.85
Flt Protected	0.95	1.00		0.95		1.00	0.95	1.00	1.00	0.95	1.00	1.00
Satd. Flow (prot)	1583	1621		1656		3378	1719	4940	1538	4848	4940	1538
Flt Permitted	0.76	1.00		0.70		1.00	0.95	1.00	1.00	0.95	1.00	1.00
Satd. Flow (perm)	1262	1621		1212		3378	1719	4940	1538	4848	4940	1538
Peak-hour factor, PHF	0.95	0.95	0.95	0.95	0.95	0.95	0.95	0.95	0.95	0.95	0.95	0.95
Adj. Flow (vph)	141	67	15	201	0	368	3	1517	79	681	2819	8
RTOR Reduction (vph)	0	6	0	0	0	0	0	0	35	0	0	2
Lane Group Flow (vph)	141	76	0	201	0	368	3	1517	44	681	2819	6
Heavy Vehicles (%)	14%	14%	14%	9%	9%	9%	5%	5%	5%	5%	5%	5%
Turn Type	pm+pt			pm+pt		pt+ov	Prot		Perm	Prot		Perm
Protected Phases	3	8		7	4	4 5	1	6		5	2	
Permitted Phases	8			4					6			2
Actuated Green, G (s)	20.7	15.4		23.1		48.6	0.8	58.4	58.4	24.9	82.5	82.5
Effective Green, g (s)	20.7	15.4		23.1		48.6	0.8	58.4	58.4	24.9	82.5	82.5
Actuated g/C Ratio	0.15	0.11		0.17		0.36	0.01	0.43	0.43	0.18	0.61	0.61
Clearance Time (s)	8.1	8.1		7.1			7.5	7.5	7.5	7.5	7.5	7.5
Vehicle Extension (s)	3.0	6.0		3.0			6.0	8.0	8.0	6.0	8.0	8.0
Lane Grp Cap (vph)	206	184		228		1212	10	2131	663	892	3010	937
v/s Ratio Prot	0.03	0.05		c0.04		0.11	0.00	0.31		c0.14	c0.57	
v/s Ratio Perm	0.08			c0.11					0.03			0.00
v/c Ratio	0.68	0.41		0.88		0.30	0.30	0.71	0.07	0.76	0.94	0.01
Uniform Delay, d1	53.7	55.8		54.0		31.2	67.0	31.6	22.5	52.5	24.1	10.4
Progression Factor	1.00	1.00		1.00		1.00	1.00	1.00	1.00	1.00	1.00	1.00
Incremental Delay, d2	9.1	4.2		30.3		0.4	42.2	2.1	0.2	5.0	7.1	0.0
Delay (s)	62.8	60.0		84.3		31.6	109.2	33.6	22.7	57.5	31.1	10.4
Level of Service	E	E		F		C	F	C	C	E	C	B
Approach Delay (s)		61.7			50.2			33.3			36.2	
Approach LOS		E			D			C			D	

### Intersection Summary

HCM Average Control Delay	37.7	HCM Level of Service	D
HCM Volume to Capacity ratio	0.90		
Actuated Cycle Length (s)	135.4	Sum of lost time (s)	22.1
Intersection Capacity Utilization	90.7%	ICU Level of Service	E
Analysis Period (min)	15		

c Critical Lane Group

HCM Signalized Intersection Capacity Analysis  
 17: Port Sutton Rd & US 41

7/23/2013



Movement	EBL	EBR	NBL	NBT	SBU	SBT	SBR
Lane Configurations							
Volume (vph)	139	98	0	1853	2	3519	7
Ideal Flow (vphpl)	1900	1900	1900	1900	1900	1900	1900
Total Lost time (s)	7.7	7.0		6.7	6.4	6.7	7.7
Lane Util. Factor	1.00	1.00		0.91	1.00	0.91	1.00
Frt	1.00	0.85		1.00	1.00	1.00	0.85
Flt Protected	0.95	1.00		1.00	0.95	1.00	1.00
Satd. Flow (prot)	1805	1615		4940	1719	4940	1538
Flt Permitted	0.95	1.00		1.00	0.95	1.00	1.00
Satd. Flow (perm)	1805	1615		4940	1719	4940	1538
Peak-hour factor, PHF	0.95	0.95	0.95	0.95	0.95	0.95	0.95
Adj. Flow (vph)	146	103	0	1951	2	3704	7
RTOR Reduction (vph)	0	1	0	0	0	0	1
Lane Group Flow (vph)	146	102	0	1951	2	3704	6
Heavy Vehicles (%)	0%	0%	5%	5%	5%	5%	5%
Turn Type		pm+ov	Prot		Prot		pm+ov
Protected Phases	8	1	1	6	5	2	8
Permitted Phases		8					2
Actuated Green, G (s)	15.7	20.7		117.3	1.0	112.7	128.4
Effective Green, g (s)	15.7	20.7		117.3	1.0	112.7	128.4
Actuated g/C Ratio	0.10	0.13		0.76	0.01	0.73	0.83
Clearance Time (s)	7.7	7.0		6.7	6.4	6.7	7.7
Vehicle Extension (s)	6.0	3.0		8.0	3.0	8.0	6.0
Lane Grp Cap (vph)	183	216		3743	11	3596	1276
v/s Ratio Prot	c0.08	c0.02		c0.39	0.00	c0.75	0.00
v/s Ratio Perm		0.05					0.00
v/c Ratio	0.80	0.47		0.52	0.18	1.03	0.00
Uniform Delay, d1	68.0	62.0		7.5	76.5	21.1	2.3
Progression Factor	1.00	1.00		1.00	1.00	1.00	1.00
Incremental Delay, d2	24.9	1.6		0.5	7.8	23.4	0.0
Delay (s)	92.9	63.6		8.0	84.3	44.5	2.3
Level of Service	F	E		A	F	D	A
Approach Delay (s)	80.8			8.0		44.4	
Approach LOS	F			A		D	

Intersection Summary			
HCM Average Control Delay	33.9	HCM Level of Service	C
HCM Volume to Capacity ratio	1.04		
Actuated Cycle Length (s)	154.8	Sum of lost time (s)	28.1
Intersection Capacity Utilization	87.7%	ICU Level of Service	E
Analysis Period (min)	15		

c Critical Lane Group

TWO-WAY STOP CONTROL SUMMARY

Analyst: AG  
 Agency/Co.: American  
 Date Performed: 06/17/2013  
 Analysis Time Period: PM Peak  
 Intersection: Hartford St & US 41  
 Jurisdiction: FDOT D7  
 Units: U. S. Customary  
 Analysis Year: 2040 Build  
 Project ID: US 41 PD&E Study  
 East/West Street: Hartford Street  
 North/South Street: US 41  
 Intersection Orientation: NS Study period (hrs): 0.25

Vehicle Volumes and Adjustments

Major Street:	Approach Movement	Northbound			Southbound		
		1 L	2 T	3 R	4 L	5 T	6 R
Volume		12	1274	37	70	2595	4
Peak-Hour Factor, PHF		0.95	0.95	0.95	0.95	0.95	0.95
Hourly Flow Rate, HFR		12	1341	38	73	2731	4
Percent Heavy Vehicles		5	--	--	5	--	--
Median Type/Storage		Raised curb			/ 1		
RT Channelized?							
Lanes		1	2	0	1	2	0
Configuration		L	T	TR	L	T	TR
Upstream Signal?		No			No		

Minor Street:	Approach Movement	Westbound			Eastbound		
		7 L	8 T	9 R	10 L	11 T	12 R
Volume		35	0	102	17	0	10
Peak Hour Factor, PHF		0.95	0.95	0.95	0.95	0.95	0.95
Hourly Flow Rate, HFR		36	0	107	17	0	10
Percent Heavy Vehicles		13	13	13	10	10	10
Percent Grade (%)		0			0		
Flared Approach: Exists?/Storage					/ No /		
Lanes		0	1	1	0	1	0
Configuration		LT		R		LTR	

Delay, Queue Length, and Level of Service

Approach	NB	SB	Westbound			Eastbound		
			7 LT	8	9 R	10	11 LTR	12
Movement	1	4	7	8	9	10	11	12
Lane Config	L	L	LT		R		LTR	
v (vph)	12	73	36		107		27	
C(m) (vph)	137	478	46		415		15	
v/c	0.09	0.15	0.78		0.26		1.80	
95% queue length	0.28	0.54	3.10		1.02		4.02	
Control Delay	33.8	13.9	207.4		16.7		901.2	
LOS	D	B	F		C		F	
Approach Delay				64.7			901.2	
Approach LOS				F			F	

Arterial Level of Service: NB US 41

Cross Street	Arterial Class	Flow Speed	Running Time	Signal Delay	Travel Time (s)	Dist (mi)	Arterial Speed	Arterial LOS
Symmes Rd	II	45	162.3	25.5	187.8	2.03	38.9	A
Palm Ave.	II	40	40.6	11.7	52.3	0.42	29.1	B
Gibsonton Dr	II	40	52.7	42.7	95.4	0.59	22.1	C
Riverview Dr	II	40	93.1	30.5	123.6	1.03	30.1	B
CR 676A (Madison Ave)	II	45	222.0	36.1	258.1	2.77	38.7	A
Port Sutton Rd	II	45	34.3	6.7	41.0	0.36	31.4	B
<b>Total</b>	<b>II</b>		<b>605.0</b>	<b>153.2</b>	<b>758.2</b>	<b>7.20</b>	<b>34.2</b>	<b>B</b>

Arterial Level of Service: SB US 41

Cross Street	Arterial Class	Flow Speed	Running Time	Signal Delay	Travel Time (s)	Dist (mi)	Arterial Speed	Arterial LOS
Port Sutton Rd	II	45	92.6	49.7	142.3	1.16	29.3	B
Pendola Point Rd	II	45	34.3	25.2	59.5	0.36	21.6	D
Industrial Access Rd	II	45	222.0	38.5	260.5	2.77	38.3	A
Alice Ave	II	40	93.1	37.7	130.8	1.03	28.5	B
Palm Ave.	II	40	52.7	20.3	73.0	0.59	28.9	B
Symmes Rd	II	40	40.6	12.8	53.4	0.42	28.5	B
<b>Total</b>	<b>II</b>		<b>535.3</b>	<b>184.2</b>	<b>719.5</b>	<b>6.33</b>	<b>31.7</b>	<b>B</b>

**Additional 2040 Build Analysis with Dual  
Left and Right Turn Lanes**

# HCM Signalized Intersection Capacity Analysis

## 40: Alice Ave & US 41

11/15/2013

Movement	EBL	EBT	EBR	WBL	WBT	WBR	NBL	NBT	NBR	SBL	SBT	SBR
Lane Configurations		↔		↔	↑	↔	↔	↑↑↑	↔	↔	↑↑↑	↔
Volume (vph)	21	38	9	499	99	771	17	2281	318	358	1341	26
Ideal Flow (vphpl)	1900	1900	1900	1900	1900	1900	1900	1900	1900	1900	1900	1900
Total Lost time (s)		9.0		9.0	9.0	9.0	6.1	6.1	6.1	6.7	6.1	
Lane Util. Factor		1.00		0.97	1.00	0.88	1.00	0.91	1.00	0.97	0.91	
Frt		0.98		1.00	1.00	0.85	1.00	1.00	0.85	1.00	1.00	
Flt Protected		0.98		0.95	1.00	1.00	0.95	1.00	1.00	0.95	1.00	
Satd Flow (prot)		1839		3303	1792	2682	1719	4940	1538	3335	4926	
Flt Permitted		0.86		0.95	1.00	1.00	0.95	1.00	1.00	0.95	1.00	
Satd Flow (perm)		1601		3303	1792	2682	1719	4940	1538	3335	4926	
Peak-hour factor, PHF	0.95	0.95	0.95	0.95	0.95	0.95	0.95	0.95	0.95	0.95	0.95	0.95
Adj Flow (vph)	22	40	9	525	104	812	18	2401	335	377	1412	27
RTOR Reduction (vph)	0	0	0	0	0	0	0	0	0	0	0	0
Lane Group Flow (vph)	0	71	0	525	104	812	18	2401	335	377	1439	0
Heavy Vehicles (%)	0%	0%	0%	6%	6%	6%	5%	5%	5%	5%	5%	5%
Turn Type	Perm			Prot		pt+ov	Prot		pt+ov	Prot		
Protected Phases		8		7	4	4.5	1	6	6.7	5	2	
Permitted Phases	8											
Actuated Green, G (s)		16.0		18.0	43.0	67.3	3.5	72.3	96.4	15.3	84.7	
Effective Green, g (s)		15.0		18.0	43.0	67.3	3.5	72.3	96.4	15.3	84.7	
Actuated g/C Ratio		0.10		0.12	0.28	0.44	0.02	0.47	0.63	0.10	0.56	
Clearance Time (s)		9.0		9.0	9.0		6.1	6.1		6.7	6.1	
Vehicle Extension (s)		3.0		3.0	6.0		3.0	8.0		3.0	8.0	
Lane Grp Cap (vph)		168		390	506	1184	39	2344	973	335	2738	
v/s Ratio Prot				c0.16	0.06	c0.30	0.01	c0.49	0.22	c0.11	0.29	
v/s Ratio Perm	0.04											
v/c Ratio	0.42			1.35	0.21	0.69	0.46	1.02	0.34	1.13	0.53	
Uniform Delay, d1	63.9			67.2	41.7	34.1	73.5	40.1	13.2	68.5	21.2	
Progression Factor	1.00			1.00	1.00	1.00	1.00	1.00	1.00	1.00	1.00	
Incremental Delay, d2	7.6			172.0	0.9	3.2	8.4	25.1	0.2	87.5	0.7	
Delay (s)	71.5			239.2	42.6	37.3	81.9	65.1	13.4	156.1	22.0	
Level of Service	E			F	D	D	F	E	B	F	C	
Approach Delay (s)	71.5				111.3			58.9			49.8	
Approach LOS	E				F			E			D	

### Intersection Summary

























HCM Average Control Delay	68.8	HCM Level of Service	E
HCM Volume to Capacity ratio	1.02		
Actuated Cycle Length (s)	152.4	Sum of lost time (s)	21.8
Intersection Capacity Utilization	97.0%	ICU Level of Service	F
Analysis Period (min)	15		

c Critical Lane Group



HCM Signalized Intersection Capacity Analysis  
 9: Industrial Access Rd & US 41

11/15/2013

												
Movement	EBL	EBT	EBR	WBL	WBT	WBR	NBL	NBT	NBR	SBL	SBT	SBR
Lane Configurations												
Volume (vph)	11	16	24	589	65	402	98	2714	291	28	1441	49
Ideal Flow (vphpl)	1900	1900	1900	1900	1900	1900	1900	1900	1900	1900	1900	1900
Total Lost time (s)	6.3	6.3	6.4	6.3	6.3	6.3	6.4	6.4	6.3	6.4	6.4	6.4
Lane Util. Factor	1.00	1.00	1.00	0.97	1.00	1.00	1.00	0.91	1.00	1.00	0.91	1.00
Frt	1.00	1.00	0.85	1.00	1.00	0.85	1.00	1.00	0.85	1.00	1.00	0.85
Flt Protected	0.95	1.00	1.00	0.95	1.00	1.00	0.95	1.00	1.00	0.95	1.00	1.00
Satd. Flow (prot)	1583	1667	1417	3303	1792	1524	1719	4940	1538	1719	4940	1538
Flt Permitted	0.71	1.00	1.00	0.95	1.00	1.00	0.95	1.00	1.00	0.95	1.00	1.00
Satd. Flow (perm)	1188	1667	1417	3303	1792	1524	1719	4940	1538	1719	4940	1538
Peak-hour factor, PHF	0.95	0.95	0.95	0.95	0.95	0.95	0.95	0.95	0.95	0.95	0.95	0.95
Adj. Flow (vph)	12	17	25	620	68	423	103	2857	306	29	1517	52
RTOR Reduction (vph)	0	0	10	0	0	0	0	0	73	0	0	0
Lane Group Flow (vph)	12	17	15	620	68	423	103	2857	233	29	1517	52
Heavy Vehicles (%)	14%	14%	14%	6%	6%	6%	5%	5%	5%	5%	5%	5%
Turn Type	Perm		pm+ov	Prot		Prot	Prot		pm+ov	Prot		Prot
Protected Phases		8	1	7	4	4	1	6	7	5	2	2
Permitted Phases	8		8						6			
Actuated Green, G (s)	9.5	9.5	23.1	28.6	44.4	44.4	13.6	85.6	114.2	3.2	75.2	75.2
Effective Green, g (s)	9.5	9.5	23.1	28.6	44.4	44.4	13.6	85.6	114.2	3.2	75.2	75.2
Actuated g/C Ratio	0.06	0.06	0.15	0.19	0.29	0.29	0.09	0.56	0.75	0.02	0.49	0.49
Clearance Time (s)	6.3	6.3	6.4	6.3	6.3	6.3	6.4	6.4	6.3	6.4	6.4	6.4
Vehicle Extension (s)	6.0	6.0	3.0	3.0	6.0	6.0	3.0	8.0	3.0	3.0	8.0	8.0
Lane Grp Cap (vph)	74	104	215	620	522	444	154	2777	1153	36	2439	759
v/s Ratio Prot		0.01	0.01	0.19	0.04	0.28	0.06	0.58	0.04	0.02	0.31	0.03
v/s Ratio Perm	0.01		0.00						0.11			
v/c Ratio	0.16	0.16	0.07	1.00	0.13	0.95	0.67	1.03	0.20	0.81	0.62	0.07
Uniform Delay, d1	67.6	67.6	55.4	61.9	39.7	52.9	67.2	33.4	5.6	74.2	28.2	20.2
Progression Factor	1.00	1.00	1.00	1.00	1.00	1.00	1.00	1.00	1.00	1.00	1.00	1.00
Incremental Delay, d2	2.9	2.1	0.1	36.1	0.3	31.8	10.5	25.0	0.1	75.6	1.2	0.2
Delay (s)	70.5	69.7	55.5	98.0	40.1	84.7	77.7	58.3	5.7	149.8	29.4	20.4
Level of Service	E	E	E	F	D	F	E	E	A	F	C	C
Approach Delay (s)		63.3			89.4			54.0			31.3	
Approach LOS		E			F			D			C	

**Intersection Summary**

HCM Average Control Delay	54.6	HCM Level of Service	D
HCM Volume to Capacity ratio	1.01		
Actuated Cycle Length (s)	152.3	Sum of lost time (s)	19.1
Intersection Capacity Utilization	99.0%	ICU Level of Service	F
Analysis Period (min)	15		

c Critical Lane Group

HCM Signalized Intersection Capacity Analysis  
 10: Pendola Point Rd & US 41

11/15/2013

Movement	EBL	EBT	EBR	WBL	WBT	WBR	NBL	NBT	NBR	SBL	SBT	SBR
Lane Configurations												
Volume (vph)	65	11	26	133	32	921	20	2628	82	485	1279	89
Ideal Flow (vphpl)	1900	1900	1900	1900	1900	1900	1900	1900	1900	1900	1900	1900
Total Lost time (s)	8.1	8.1		7.1	7.1	7.1	7.5	7.5	7.5	7.5	7.5	7.5
Lane Util. Factor	1.00	1.00		1.00	1.00	0.88	1.00	0.91	1.00	0.97	0.91	1.00
Frt	1.00	0.90		1.00	1.00	0.85	1.00	1.00	0.85	1.00	1.00	0.85
Flt Protected	0.95	1.00		0.95	1.00	1.00	0.95	1.00	1.00	0.95	1.00	1.00
Satd Flow (prot)	1157	1091		1641	1727	2584	1719	4940	1538	3335	4940	1538
Flt Permitted	0.73	1.00		0.58	1.00	1.00	0.95	1.00	1.00	0.95	1.00	1.00
Satd Flow (perm)	395	1091		998	1727	2584	1719	4940	1538	3335	4940	1538
Peak-hour factor, PHF	0.95	0.95	0.95	0.95	0.95	0.95	0.95	0.95	0.95	0.95	0.95	0.95
Adj. Flow (vph)	68	12	27	140	34	969	21	2766	86	511	1346	94
RTOR Reduction (vph)	0	25	0	0	0	34	0	0	19	0	0	35
Lane Group Flow (vph)	68	14	0	140	34	935	21	2766	67	511	1346	59
Heavy Vehicles (%)	56%	56%	56%	10%	10%	10%	5%	5%	5%	5%	5%	5%
Turn Type	pm+pt			pm+pt		pt+cv	Prot		Perm	Prot		Perm
Protected Phases	3	8		7	4	4 5	1	6		5	2	
Permitted Phases	8			4					6			2
Actuated Green, G (s)	17.3	14.0		27.3	19.0	46.6	3.6	79.3	79.3	20.5	96.2	96.2
Effective Green, g (s)	17.3	14.0		27.3	19.0	46.6	3.6	79.3	79.3	20.5	96.2	96.2
Actuated g/C Ratio	0.11	0.09		0.18	0.12	0.31	0.02	0.52	0.52	0.13	0.63	0.63
Clearance Time (s)	8.1	8.1		7.1	7.1		7.5	7.5	7.5	7.5	7.5	7.5
Vehicle Extension (s)	3.0	6.0		3.0	6.0		3.0	8.0	8.0	6.0	8.0	8.0
Lane Grp Cap (vph)	107	100		214	215	791	41	2572	801	449	3120	971
v/s Ratio Prot	0.01	0.01		0.04	0.02	0.36	0.01	0.56		0.15	0.27	
v/s Ratio Perm	0.06			0.08					0.04			0.04
v/c Ratio	0.64	0.14		0.65	0.16	1.18	0.51	1.08	0.08	1.14	0.43	0.06
Uniform Delay, d1	64.0	63.6		57.3	59.5	52.9	73.5	36.5	18.3	65.9	14.2	10.7
Progression Factor	1.00	1.00		1.00	1.00	1.00	1.00	1.00	1.00	1.00	1.00	1.00
Incremental Delay, d2	11.7	1.9		7.0	1.0	94.7	10.4	42.0	0.2	86.0	0.4	0.1
Delay (s)	75.7	65.5		64.3	60.5	147.5	83.9	78.5	18.5	151.9	14.6	10.9
Level of Service	E	E		E	E	F	F	E	B	F	B	B
Approach Delay (s)		72.0			134.8			76.7			50.4	
Approach LOS		E			F			E			D	

**Intersection Summary**





















HCM Average Control Delay	79.1	HCM Level of Service	E
HCM Volume to Capacity ratio	1.12		
Actuated Cycle Length (s)	152.3	Sum of lost time (s)	21.7
Intersection Capacity Utilization	105.5%	ICU Level of Service	G
Analysis Period (min)	15		

c Critical Lane Group

# HCM Signalized Intersection Capacity Analysis

## 40: Alice Ave & US 41

11/15/2013

												
Movement	EBL	EBT	EBR	WBL	WBT	WBR	NBL	NBT	NBR	SBL	SBT	SBR
Lane Configurations												
Volume (vph)	12	27	19	573	77	239	16	996	442	722	2356	25
Ideal Flow (vphpl)	1900	1900	1900	1900	1900	1900	1900	1900	1900	1900	1900	1900
Total Lost time (s)		9.0		9.0	9.0	9.0	6.1	6.1	6.1	6.7	6.1	
Lane Util. Factor		1.00		0.97	1.00	0.88	1.00	0.91	1.00	0.97	0.91	
Frt		0.96		1.00	1.00	0.85	1.00	1.00	0.85	1.00	1.00	
Flt Protected		0.99		0.95	1.00	1.00	0.95	1.00	1.00	0.95	1.00	
Satd. Flow (prot)		1695		3335	1810	2707	1719	4940	1538	3335	4932	
Flt Permitted		0.90		0.95	1.00	1.00	0.95	1.00	1.00	0.95	1.00	
Satd. Flow (perm)		1548		3335	1810	2707	1719	4940	1538	3335	4932	
Peak-hour factor, PHF	0.95	0.95	0.95	0.95	0.95	0.95	0.95	0.95	0.95	0.95	0.95	0.95
Adj. Flow (vph)	13	28	20	603	81	252	17	1048	465	760	2480	26
RTOR Reduction (vph)	0	0	0	0	0	0	0	0	0	0	0	0
Lane Group Flow (vph)	0	61	0	603	81	252	17	1048	465	760	2506	0
Heavy Vehicles (%)	6%	6%	6%	5%	5%	5%	5%	5%	5%	5%	5%	5%
Turn Type	Perm			Prot		pt+ov	Prot		pt+ov	Prot		
Protected Phases		8		7	4	4 5	1	6	6 7	5	2	
Permitted Phases	8											
Actuated Green, G (s)		16.0		26.0	51.0	98.9	2.4	42.0	74.1	38.9	79.1	
Effective Green, g (s)		16.0		26.0	51.0	98.9	2.4	42.0	74.1	38.9	79.1	
Actuated g/C Ratio		0.10		0.17	0.33	0.64	0.02	0.27	0.48	0.25	0.51	
Clearance Time (s)		9.0		9.0	9.0		6.1	6.1		6.7	6.1	
Vehicle Extension (s)		3.0		3.0	6.0		3.0	8.0		3.0	8.0	
Lane Grp Cap (vph)		161		564	601	1742	27	1350	741	844	2538	
v/s Ratio Prot				c0.18	0.04	0.09	0.01	0.21	0.30	c0.23	c0.51	
v/s Ratio Perm		c0.04										
v/c Ratio		0.38		1.07	0.13	0.14	0.63	0.78	0.63	0.90	0.99	
Uniform Delay, d1		64.2		63.8	35.9	10.8	75.2	51.5	29.6	55.5	36.8	
Progression Factor		1.00		1.00	1.00	1.00	1.00	1.00	1.00	1.00	1.00	
Incremental Delay, d2		6.7		5.7	0.5	0.2	38.0	4.4	1.7	14.6	15.1	
Delay (s)		70.9		121.6	36.4	10.9	113.2	55.9	31.2	70.1	51.9	
Level of Service		E		F	D	B	F	E	C	E	D	
Approach Delay (s)		70.9			84.4			49.1			56.2	
Approach LOS		E			F			D			E	

### Intersection Summary

HCM Average Control Delay	59.0	HCM Level of Service	E
HCM Volume to Capacity ratio	0.95		
Actuated Cycle Length (s)	153.7	Sum of lost time (s)	30.8
Intersection Capacity Utilization	90.1%	ICU Level of Service	E
Analysis Period (min)	15		

c Critical Lane Group

HCM Signalized Intersection Capacity Analysis  
 9: Industrial Access Rd & US 41

11/15/2013

Movement	EBL	EBT	EBR	WBL	WBT	WBR	NBL	NBT	NBR	SBL	SBT	SBR
Lane Configurations												
Volume (vph)	33	55	68	702	14	68	25	1213	488	164	2549	17
Ideal Flow (vphpl)	1900	1900	1900	1900	1900	1900	1900	1900	1900	1900	1900	1900
Total Lost time (s)	6.3	6.3	6.4	6.3	6.3	6.3	6.4	6.4	6.3	6.4	6.4	6.4
Lane Util. Factor	1.00	1.00	1.00	0.97	1.00	1.00	1.00	0.91	1.00	1.00	0.91	1.00
Frt	1.00	1.00	0.85	1.00	1.00	0.85	1.00	1.00	0.85	1.00	1.00	0.85
Flt Protected	0.95	1.00	1.00	0.95	1.00	1.00	0.95	1.00	1.00	0.95	1.00	1.00
Satd. Flow (prot)	1787	1881	1599	3433	1863	1583	1719	4940	1538	1719	4940	1538
Flt Permitted	0.75	1.00	1.00	0.95	1.00	1.00	0.95	1.00	1.00	0.95	1.00	1.00
Satd. Flow (perm)	1407	1881	1599	3433	1863	1583	1719	4940	1538	1719	4940	1538
Peak-hour factor, PHF	0.95	0.95	0.95	0.95	0.95	0.95	0.95	0.95	0.95	0.95	0.95	0.95
Adj. Flow (vph)	35	58	72	739	15	72	26	1277	514	173	2683	18
RTOR Reduction (vph)	0	0	1	0	0	0	0	0	143	0	0	0
Lane Group Flow (vph)	35	58	71	739	15	72	26	1277	371	173	2683	18
Heavy Vehicles (%)	1%	1%	1%	2%	2%	2%	5%	5%	5%	5%	5%	5%
Turn Type	Perm		pm+ov	Prot		Prot	Prot		pm+ov	Prot		Prot
Protected Phases		8	1	7	4	4	1	6	7	5	2	2
Permitted Phases	8		8						6			
Actuated Green, G (s)	10.6	10.6	14.6	27.1	44.0	44.0	4.0	64.2	91.3	17.7	77.9	77.9
Effective Green, g (s)	10.6	10.6	14.6	27.1	44.0	44.0	4.0	64.2	91.3	17.7	77.9	77.9
Actuated g/C Ratio	0.07	0.07	0.10	0.19	0.30	0.30	0.03	0.44	0.63	0.12	0.54	0.54
Clearance Time (s)	6.3	6.3	6.4	6.3	6.3	6.3	6.4	6.4	6.3	6.4	6.4	6.4
Vehicle Extension (s)	6.0	6.0	3.0	3.0	6.0	6.0	3.0	8.0	3.0	3.0	8.0	8.0
Lane Grp Cap (vph)	103	138	161	642	565	480	47	2187	968	210	2654	826
v/s Ratio Prot		0.03	c0.01	c0.22	0.01	0.05	0.02	0.26	0.07	c0.10	c0.54	0.01
v/s Ratio Perm	0.02		0.03						0.17			
v/c Ratio	0.34	0.42	0.44	1.15	0.03	0.15	0.55	0.58	0.38	0.82	1.01	0.02
Uniform Delay, d1	63.9	64.3	61.4	58.9	35.5	36.9	69.6	30.4	13.1	62.1	33.5	15.7
Progression Factor	1.00	1.00	1.00	1.00	1.00	1.00	1.00	1.00	1.00	1.00	1.00	1.00
Incremental Delay, d2	5.5	5.7	1.9	85.1	0.1	0.4	13.3	1.1	0.3	22.3	20.2	0.0
Delay (s)	69.4	70.0	63.3	144.0	35.5	37.3	83.0	31.5	13.4	84.4	53.7	15.8
Level of Service	E	E	E	F	D	D	F	C	B	F	D	B
Approach Delay (s)		66.9			132.7			27.1			55.4	
Approach LOS		E			F			C			E	

Intersection Summary

HCM Average Control Delay	57.9	HCM Level of Service	E
HCM Volume to Capacity ratio	1.01		
Actuated Cycle Length (s)	145.0	Sum of lost time (s)	25.5
Intersection Capacity Utilization	95.2%	ICU Level of Service	F
Analysis Period (min)	15		

c Critical Lane Group

HCM Signalized Intersection Capacity Analysis  
 10: Pendola Point Rd & US 41

11/15/2013

Movement	EBL	EBT	EBR	WBL	WBT	WBR	NBL	NBT	NBR	SBL	SBT	SBR
Lane Configurations												
Volume (vph)	134	64	14	191	0	350	3	1441	75	647	2678	8
Ideal Flow (vphpl)	1900	1900	1900	1900	1900	1900	1900	1900	1900	1900	1900	1900
Total Lost time (s)	8.1	8.1		7.1		7.1	7.5	7.5	7.5	7.5	7.5	7.5
Lane Util. Factor	1.00	1.00		1.00		0.88	1.00	0.91	1.00	0.97	0.91	1.00
Frt	1.00	0.97		1.00		0.85	1.00	1.00	0.85	1.00	1.00	0.85
Flt Protected	0.95	1.00		0.95		1.00	0.95	1.00	1.00	0.95	1.00	1.00
Satd Flow (prot)	1583	1621		1656		2608	1719	4940	1538	3335	4940	1538
Flt Permitted	0.76	1.00		0.70		1.00	0.95	1.00	1.00	0.95	1.00	1.00
Satd Flow (perm)	1262	1621		1212		2608	1719	4940	1538	3335	4940	1538
Peak-hour factor, PHF	0.95	0.95	0.95	0.95	0.95	0.95	0.95	0.95	0.95	0.95	0.95	0.95
Adj Flow (vph)	141	67	15	201	0	368	3	1517	79	681	2819	8
RTOR Reduction (vph)	0	6	0	0	0	0	0	0	35	0	0	2
Lane Group Flow (vph)	141	76	0	201	0	368	3	1517	44	681	2819	6
Heavy Vehicles (%)	14%	14%	14%	9%	9%	9%	5%	5%	5%	5%	5%	5%
Turn Type	pm+pt			pm+pt		pt+ov	Prot		Perm	Prot		Perm
Protected Phases	3	8		7	4	4 5	1	6		5		2
Permitted Phases	8			4					6			2
Actuated Green, G (s)	21.1	15.8		23.5		54.6	0.8	52.8	52.8	30.5	82.5	82.5
Effective Green, g (s)	21.1	15.8		23.5		54.6	0.8	52.8	52.8	30.5	82.5	82.5
Actuated g/C Ratio	0.16	0.12		0.17		0.40	0.01	0.39	0.39	0.22	0.61	0.61
Clearance Time (s)	8.1	8.1		7.1			7.5	7.5	7.5	7.5	7.5	7.5
Vehicle Extension (s)	3.0	6.0		3.0			6.0	8.0	8.0	6.0	8.0	8.0
Lane Grp Cap (vph)	209	189		231		1049	10	1921	598	749	3001	934
v/s Ratio Prot	0.03	0.05		0.04		0.14	0.00	0.31		0.20	0.57	
v/s Ratio Perm	0.08			0.11					0.03			0.00
v/c Ratio	0.67	0.40		0.87		0.35	0.30	0.79	0.07	0.91	0.94	0.01
Uniform Delay, d1	53.6	55.6		53.9		28.3	67.2	36.6	26.1	51.3	24.4	10.5
Progression Factor	1.00	1.00		1.00		1.00	1.00	1.00	1.00	1.00	1.00	1.00
Incremental Delay, d2	8.3	3.9		28.0		0.6	42.2	3.4	0.2	16.2	7.3	0.0
Delay (s)	61.9	59.5		81.8		28.8	109.4	40.0	26.3	67.5	31.7	10.5
Level of Service	E	E		F		C	F	D	C	E	C	B
Approach Delay (s)		61.0			47.6			39.5			38.6	
Approach LOS		E			D			D			D	

Intersection Summary	
HCM Average Control Delay	40.5
HCM Volume to Capacity ratio	0.91
Actuated Cycle Length (s)	135.8
Intersection Capacity Utilization	90.7%
Analysis Period (min)	15
HCM Level of Service	D
Sum of lost time (s)	22.1
ICU Level of Service	E

c Critical Lane Group

**Additional 2040 Analysis with 6-Laning of  
US 41 and Existing Geometry for Side-  
Streets and Turn Lanes**

HCM Signalized Intersection Capacity Analysis  
 35: Symmes Rd & US 41

11/15/2013

Movement	EBL	EBT	EBR	WBL	WBT	WBR	MBL	NBT	NBR	SEB	SEB	SBR
Lane Configurations		↕		↖	↗		↖	↑↑↑	↗	↖	↑↑↑	
Volume (vph)	1	0	0	311	0	728	17	2019	218	211	1236	0
Ideal Flow (vphpl)	1900	1900	1900	1900	1900	1900	1900	1900	1900	1900	1900	1900
Total Lost time (s)		7.2		7.2	7.2		6.2	6.2	7.2	7.0	6.2	
Lane Util. Factor		1.00		1.00	1.00		1.00	0.91	1.00	1.00	0.91	
Frt		1.00		1.00	0.85		1.00	1.00	0.85	1.00	1.00	
Flt Protected		0.95		0.95	1.00		0.95	1.00	1.00	0.95	1.00	
Satd Flow (prot)		1805		1703	1524		1719	4940	1538	1719	4940	
Flt Permitted		1.00		0.95	1.00		0.95	1.00	1.00	0.95	1.00	
Satd Flow (perm)		1900		1703	1524		1719	4940	1538	1719	4940	
Peak-hour factor, PHF	0.95	0.95	0.95	0.95	0.95	0.95	0.95	0.95	0.95	0.95	0.95	0.95
Adj Flow (vph)	1	0	0	327	0	766	18	2125	229	222	1301	0
RTOR Reduction (vph)	0	0	0	0	0	0	0	0	66	0	0	0
Lane Group Flow (vph)	0	1	0	327	766	0	18	2125	163	222	1301	0
Heavy Vehicles (%)	0%	0%	0%	6%	6%	6%	5%	5%	5%	5%	5%	5%
Turn Type	Perm			Prot			Prot		pm+ov	Prot		
Protected Phases		8		7	4		1	6	7	5	2	
Permitted Phases	8								6			
Actuated Green, G (s)		2.1		56.3	65.6		3.5	56.2	112.5	16.0	69.5	
Effective Green, g (s)		2.1		56.3	65.6		3.5	56.2	112.5	16.0	69.5	
Actuated g/C Ratio		0.01		0.36	0.41		0.02	0.36	0.71	0.10	0.44	
Clearance Time (s)		7.2		7.2	7.2		6.2	6.2	7.2	7.0	6.2	
Vehicle Extension (s)		3.0		3.0	3.0		3.0	4.0	3.0	3.0	4.0	
Lane Grp Cap (vph)		25		606	632		38	1755	1094	174	2170	
v/s Ratio Prot				0.19	0.50		0.01	0.43	0.05	0.13	0.26	
v/s Ratio Perm		0.00							0.05			
v/c Ratio		0.04		0.54	1.21		0.47	1.21	0.15	1.28	0.60	
Uniform Delay, d1		77.1		40.6	46.3		76.4	51.0	7.4	71.1	33.8	
Progression Factor		1.00		1.00	1.00		1.00	1.00	1.00	1.00	1.00	
Incremental Delay, d2		0.7		0.9	109.6		9.0	100.4	0.1	161.0	0.5	
Delay (s)		77.7		41.5	155.9		85.5	151.4	7.4	232.1	34.3	
Level of Service		E		D	F		F	F	A	F	C	
Approach Delay (s)		77.7			121.7			137.0			63.1	
Approach LOS		E			F			F			E	

Intersection Summary

HCM Average Control Delay	111.1	HCM Level of Service	F
HCM Volume to Capacity ratio	1.22		
Actuated Cycle Length (s)	158.2	Sum of lost time (s)	20.4
Intersection Capacity Utilization	112.8%	ICU Level of Service	H
Analysis Period (min)	15		

c Critical Lane Group

HCM Signalized Intersection Capacity Analysis  
 40: Alice Ave & US 41

11/15/2013



Movement	EBL	EBT	EBR	WBL	WBT	WBR	NBL	NBT	NBR	SBL	SBT	SBR
Lane Configurations		↕		↙	↘	↗	↙	↑↑↑	↗	↙	↑↑↑	↘
Volume (vph)	21	38	9	499	99	771	17	2281	318	358	1341	26
Ideal Flow (vphpl)	1900	1900	1900	1900	1900	1900	1900	1900	1900	1900	1900	1900
Total Lost time (s)		9.0		9.0	9.0	9.0	6.1	6.1	6.1	6.7	6.1	
Lane Util. Factor		1.00		1.00	1.00	1.00	1.00	0.91	1.00	1.00	0.91	
Frt		0.98		1.00	1.00	0.85	1.00	1.00	0.85	1.00	1.00	
Flt Protected		0.98		0.95	1.00	1.00	0.95	1.00	1.00	0.95	1.00	
Satd Flow (prot)		1839		1703	1792	1524	1719	4940	1538	1719	4926	
Flt Permitted		0.86		0.95	1.00	1.00	0.95	1.00	1.00	0.95	1.00	
Satd Flow (perm)		1601		1703	1792	1524	1719	4940	1538	1719	4926	
Peak-hour factor, PHF	0.95	0.95	0.95	0.95	0.95	0.95	0.95	0.95	0.95	0.95	0.95	0.95
Adj Flow (vph)	22	40	9	525	104	812	18	2401	335	377	1412	27
RTOR Reduction (vph)	0	0	0	0	0	0	0	0	0	0	0	0
Lane Group Flow (vph)	0	71	0	525	104	812	18	2401	335	377	1439	0
Heavy Vehicles (%)	0%	0%	0%	6%	6%	6%	5%	5%	5%	5%	5%	5%
Turn Type	Perm			Prot		pt+ov	Prot		pt+ov	Prot		
Protected Phases		8		7	4	4.5	1	6	6.7	5	2	
Permitted Phases	8											
Actuated Green, G (s)		16.0		30.0	55.0	86.3	3.5	53.3	89.4	22.3	72.7	
Effective Green, g (s)		16.0		30.0	55.0	86.3	3.5	53.3	89.4	22.3	72.7	
Actuated g/C Ratio		0.10		0.20	0.36	0.57	0.02	0.35	0.59	0.15	0.48	
Clearance Time (s)		9.0		9.0	9.0		6.1	6.1		6.7	6.1	
Vehicle Extension (s)		3.0		3.0	6.0		3.0	8.0		3.0	8.0	
Lane Grp Cap (vph)		168		335	647	863	39	1728	902	252	2350	
v/s Ratio Prot				c0.31	0.06	c0.53	0.01	c0.49	0.22	c0.22	0.29	
v/s Ratio Perm		0.04										
v/c Ratio		0.42		1.57	0.16	0.94	0.46	1.39	0.37	1.50	0.61	
Uniform Delay, d1		63.9		61.2	33.0	30.7	73.5	49.6	16.6	65.0	29.4	
Progression Factor		1.00		1.00	1.00	1.00	1.00	1.00	1.00	1.00	1.00	
Incremental Delay, d2		7.6		269.3	0.5	19.3	8.4	178.9	0.3	243.0	1.2	
Delay (s)		71.5		330.5	33.6	49.9	81.9	228.5	16.9	308.1	30.6	
Level of Service		E		F	C	D	F	F	B	F	C	
Approach Delay (s)		71.5			151.0			201.8			88.2	
Approach LOS		E			F			F			F	

**Intersection Summary**

HCM Average Control Delay	154.3	HCM Level of Service	F
HCM Volume to Capacity ratio	1.36		
Actuated Cycle Length (s)	152.4	Sum of lost time (s)	21.8
Intersection Capacity Utilization	117.7%	ICU Level of Service	H
Analysis Period (min)	15		

c Critical Lane Group



HCM Signalized Intersection Capacity Analysis  
 9: Industrial Access Rd & US 41

11/15/2013

Movement	EBL	EBT	EBR	WBL	WBT	WBR	NBL	NBT	NBR	SBL	SBT	SBR
Lane Configurations												
Volume (vph)	11	16	24	589	65	402	98	2714	291	28	1441	49
Ideal Flow (vphpl)	1900	1900	1900	1900	1900	1900	1900	1900	1900	1900	1900	1900
Total Lost time (s)		6.3	6.4		6.3	6.3	6.4	6.4	6.4	6.4	6.4	6.4
Lane Util. Factor		1.00	1.00		1.00	1.00	1.00	0.91	1.00	1.00	0.91	1.00
Flt		1.00	0.85		1.00	0.85	1.00	1.00	0.85	1.00	1.00	0.85
Flt Protected		0.98	1.00		0.96	1.00	0.95	1.00	1.00	0.95	1.00	1.00
Satd Flow (prot)		1633	1417		1715	1524	1719	4940	1538	1719	4940	1538
Flt Permitted		0.43	1.00		0.73	1.00	0.95	1.00	1.00	0.95	1.00	1.00
Satd Flow (perm)		713	1417		1302	1524	1719	4940	1538	1719	4940	1538
Peak-hour factor, PHF	0.95	0.95	0.95	0.95	0.95	0.95	0.95	0.95	0.95	0.95	0.95	0.95
Adj Flow (vph)	12	17	25	620	68	423	103	2857	306	29	1517	52
RTOR Reduction (vph)	0	0	11	0	0	0	0	0	75	0	0	0
Lane Group Flow (vph)	0	29	14	0	688	423	103	2857	231	29	1517	52
Heavy Vehicles (%)	14%	14%	14%	6%	6%	6%	5%	5%	5%	5%	5%	5%
Turn Type	Perm		pm+ov	Perm		Frot	Prot		Perm	Prot		Prot
Protected Phases		8	1		4	4	1	6		5	2	2
Permitted Phases	6		8	4					6			
Actuated Green, G (s)		43.5	55.5		43.5	43.5	12.0	84.8	84.8	3.2	76.0	76.0
Effective Green, g (s)		43.5	55.5		43.5	43.5	12.0	84.8	84.8	3.2	76.0	76.0
Actuated g/C Ratio		0.29	0.37		0.29	0.29	0.08	0.56	0.56	0.02	0.50	0.50
Clearance Time (s)		6.3	6.4		6.3	6.3	6.4	6.4	6.4	6.4	6.4	6.4
Vehicle Extension (s)		6.0	3.0		6.0	6.0	3.0	8.0	8.0	3.0	8.0	8.0
Lane Grp Cap (vph)		206	522		376	440	137	2782	866	37	2493	776
v/s Ratio Prot			0.00			0.28	0.06	0.58		0.02	0.31	0.03
v/s Ratio Perm	0.04	0.01		0.53					0.15			
v/c Ratio	0.14	0.03		1.83	0.96	0.75	1.03	0.27	0.78	0.61	0.07	
Uniform Delay, d1	39.7	30.3		53.5	52.7	67.8	32.9	16.9	73.4	26.7	19.1	
Progression Factor	1.00	1.00		1.00	1.00	1.00	1.00	1.00	1.00	1.00	1.00	
Incremental Delay, d2	0.9	0.0		383.7	33.8	20.5	24.4	0.8	67.8	1.1	0.2	
Delay (s)	40.6	30.4		437.2	86.5	88.4	57.3	17.7	141.1	27.8	19.3	
Level of Service	D	C		F	F	F	E	B	F	C	B	
Approach Delay (s)	35.8			303.7			54.6			29.6		
Approach LOS	D			F			D			C		

Intersection Summary

HCM Average Control Delay	93.7	HCM Level of Service	F
HCM Volume to Capacity ratio	1.31		
Actuated Cycle Length (s)	150.6	Sum of lost time (s)	19.1
Intersection Capacity Utilization	114.4%	ICU Level of Service	H
Analysis Period (min)	15		

c Critical Lane Group

HCM Signalized Intersection Capacity Analysis  
 10: Pendola Point Rd & US 41

11/15/2013

Movement	EBL	EBT	EBR	WBL	WBT	WBR	NBL	NBT	NBR	SBL	SBT	SBR
Lane Configurations	↖	↗			↖	↗	↖	↑↑↑	↗	↖↗	↑↑↑	↖
Volume (vph)	65	11	26	133	32	921	20	2628	82	485	1279	89
Ideal Flow (vphpl)	1900	1900	1900	1900	1900	1900	1900	1900	1900	1900	1900	1900
Total Lost time (s)	8.1	8.1			7.1	7.1	7.5	7.5	7.5	7.5	7.5	7.5
Lane Util. Factor	1.00	1.00			1.00	0.88	1.00	0.91	1.00	0.97	0.91	1.00
Flt	1.00	0.90			1.00	0.35	1.00	1.00	0.85	1.00	1.00	0.85
Flt Protected	0.95	1.00			0.96	1.00	0.95	1.00	1.00	0.95	1.00	1.00
Satd. Flow (prot)	1157	1091			1660	2584	1719	4940	1538	3335	4940	1538
Flt Permitted	0.47	1.00			0.74	1.00	0.95	1.00	1.00	0.95	1.00	1.00
Satd. Flow (perm)	570	1091			1280	2584	1719	4940	1538	3335	4940	1538
Peak-hour factor, PHF	0.95	0.95	0.95	0.95	0.95	0.95	0.95	0.95	0.95	0.95	0.95	0.95
Adj. Flow (vph)	68	12	27	140	34	969	21	2766	86	511	1346	94
RTOR Reduction (vph)	0	23	0	0	0	1	0	0	19	0	0	31
Lane Group Flow (vph)	68	16	0	0	174	968	21	2766	67	511	1346	63
Heavy Vehicles (%)	56%	56%	56%	10%	10%	10%	5%	5%	5%	5%	5%	5%
Turn Type	Perm			Perm		pl+ov	Prot		Perm	Prot		Perm
Protected Phases		8			4	4 5	1	6		5		2
Permitted Phases	3			4					6			2
Actuated Green, G (s)	23.9	23.9			24.9	53.7	3.7	84.3	84.3	21.7	102.3	102.3
Effective Green, g (s)	23.9	23.9			24.9	53.7	3.7	84.3	84.3	21.7	102.3	102.3
Actuated g/C Ratio	0.16	0.16			0.16	0.35	0.02	0.55	0.55	0.14	0.67	0.67
Clearance Time (s)	8.1	8.1			7.1		7.5	7.5	7.5	7.5	7.5	7.5
Vehicle Extension (s)	6.0	6.0			6.0		3.0	8.0	8.0	6.0	8.0	8.0
Lane Grp Cap (vph)	89	170			208	907	42	2722	847	473	3303	1028
v/s Ratio Prot		0.01				c0.37	0.01	c0.56		c0.15	0.27	
v/s Ratio Perm	0.12				0.14				0.04			0.04
v/c Ratio	0.76	0.10			0.84	1.07	0.50	1.02	0.08	1.08	0.41	0.06
Uniform Delay, d1	61.8	55.3			62.1	49.6	73.7	34.4	16.1	65.7	11.5	8.8
Progression Factor	1.00	1.00			1.00	1.00	1.00	1.00	1.00	1.00	1.00	1.00
Incremental Delay, d2	38.9	0.7			27.6	49.6	9.1	21.4	0.2	64.7	0.4	0.1
Delay (s)	100.8	56.0			89.7	99.3	82.8	55.8	16.3	130.4	11.9	8.9
Level of Service	F	E			F	F	F	E	B	F	B	A
Approach Delay (s)		84.4			97.8			54.8			42.8	
Approach LOS		F			F			D			D	

Intersection Summary

HCM Average Control Delay	59.8	HCM Level of Service	E
HCM Volume to Capacity ratio	1.03		
Actuated Cycle Length (s)	153.0	Sum of lost time (s)	14.6
Intersection Capacity Utilization	106.9%	ICU Level of Service	G
Analysis Period (min)	15		

c Critical Lane Group

## Arterial Level of Service

11/15/2013

### Arterial Level of Service: NB US 41

Cross Street	Arterial Class	Flow Speed	Running Time	Signal Delay	Travel Time (s)	Dist (mi)	Arterial Speed	Arterial LOS
Symmes Rd	II	45	162.3	137.2	299.5	2.03	24.4	C
Palm Ave.	II	40	40.6	18.5	59.1	0.42	25.7	C
Gibsonton Dr	II	40	52.7	234.9	287.6	0.59	7.3	F
Riverview Dr	II	40	93.1	53.9	147.0	1.03	25.3	C
CR 676A (Madison Ave	II	45	222.0	60.5	282.5	2.77	35.4	A
Port Sutton Rd	II	45	34.3	20.0	54.3	0.36	23.7	C
Total	II		605.0	525.0	1130.0	7.20	22.9	C

### Arterial Level of Service: SB US 41

Cross Street	Arterial Class	Flow Speed	Running Time	Signal Delay	Travel Time (s)	Dist (mi)	Arterial Speed	Arterial LOS
Port Sutton Rd	II	45	92.6	11.4	104.0	1.16	40.0	A
Pendola Point Rd	II	45	34.3	11.4	45.7	0.36	28.2	B
Industrial Access Rd	II	45	222.0	28.3	250.3	2.77	39.9	A
Alice Ave	II	40	93.1	30.2	123.3	1.03	30.2	B
Palm Ave	II	40	52.7	11.6	64.3	0.59	32.8	B
Symmes Rd	II	40	40.6	31.2	71.8	0.42	21.2	D
Total	II		535.3	124.1	659.4	6.33	34.6	B

HCM Signalized Intersection Capacity Analysis  
 35: Symmes Rd & US 41

11/15/2013

Movement	EBL	EBT	EBR	WBL	WBT	WBR	NBL	NBT	NBR	SBL	SBT	SBR
Lane Configurations		↔		↖	↗		↖	↑↑↑	↗	↖	↑↑↑	
Volume (vph)	0	2	0	215	0	244	3	1115	134	535	2063	5
Ideal Flow (vphpl)	1900	1900	1900	1900	1900	1900	1900	1900	1900	1900	1900	1900
Total Lost time (s)		7.2		7.2	7.2		6.2	6.2	7.2	7.0	6.2	
Lane Util. Factor		1.00		1.00	1.00		1.00	0.91	1.00	1.00	0.91	
Flt		1.00		1.00	0.85		1.00	1.00	0.85	1.00	1.00	
Flt Protected		1.00		0.95	1.00		0.95	1.00	1.00	0.95	1.00	
Satd. Flow (prot)		1900		1736	1553		1719	4940	1538	1719	4938	
Flt Permitted		1.00		0.95	1.00		0.95	1.00	1.00	0.95	1.00	
Satd. Flow (perm)		1900		1736	1553		1719	4940	1538	1719	4938	
Peak-hour factor, PHF	0.95	0.95	0.95	0.95	0.95	0.95	0.95	0.95	0.95	0.95	0.95	0.95
Adj. Flow (vph)	0	2	0	226	0	257	3	1174	141	563	2172	5
RTOR Reduction (vph)	0	0	0	0	0	0	0	0	79	0	0	0
Lane Group Flow (vph)	0	2	0	226	257	0	3	1174	62	563	2177	0
Heavy Vehicles (%)	0%	0%	0%	4%	4%	4%	5%	5%	5%	5%	5%	5%
Turn Type	Perm			Prot			Prot		pm+ov		Prot	
Protected Phases		8		7	4		1	6	7		5	2
Permitted Phases	8								6			
Actuated Green, G (s)		1.3		19.0	27.5		0.7	30.9	49.9		35.1	66.1
Effective Green, g (s)		1.3		19.0	27.5		0.7	30.9	49.9		35.1	66.1
Actuated g/C Ratio		0.01		0.17	0.24		0.01	0.27	0.44		0.31	0.58
Clearance Time (s)		7.2		7.2	7.2		6.2	6.2	7.2		7.0	6.2
Vehicle Extension (s)		3.0		3.0	3.0		3.0	4.0	3.0		3.0	4.0
Lane Grp Cap (vph)		22		290	375		11	1340	674		530	2866
v/s Ratio Prot		0.00		0.13	0.17		0.00	0.24	0.02		0.33	0.44
v/s Ratio Perm									0.02			
v/c Ratio		0.09		0.78	0.69		0.27	0.88	0.09		1.06	0.76
Uniform Delay, d1		55.7		45.4	39.3		56.3	39.7	18.7		39.4	17.9
Progression Factor		1.00		1.00	1.00		1.00	1.00	1.00		1.00	1.00
Incremental Delay, d2		1.8		12.4	5.1		13.0	6.9	0.1		56.7	1.3
Delay (s)		57.5		57.9	44.4		69.3	46.6	18.8		96.1	19.2
Level of Service		E		E	D		E	D	B		F	B
Approach Delay (s)		57.5			50.7			43.7				35.0
Approach LOS		E			D			D				D

Intersection Summary

HCM Average Control Delay	39.2	HCM Level of Service	D
HCM Volume to Capacity ratio	0.89		
Actuated Cycle Length (s)	113.9	Sum of lost time (s)	20.4
Intersection Capacity Utilization	86.8%	ICU Level of Service	E
Analysis Period (min)	15		

c Critical Lane Group

HCM Signalized Intersection Capacity Analysis  
 40: Alice Ave & US 41

11/15/2013

Movement	EBL	EBT	EBR	WBL	WBT	WBR	NBL	NBT	NBR	SBL	SBT	SBR
Lane Configurations		↔		↖	↗	↗	↖	↑↑↑	↗	↖	↑↑↑	
Volume (vph)	12	27	19	573	77	239	16	996	442	722	2356	25
Ideal Flow (vphpl)	1900	1900	1900	1900	1900	1900	1900	1900	1900	1900	1900	1900
Total Lost time (s)		9.0		9.0	9.0	9.0	6.1	6.1	6.1	6.7	6.1	
Lane Util. Factor		1.00		1.00	1.00	1.00	1.00	0.91	1.00	1.00	0.91	
Fit		0.96		1.00	1.00	0.85	1.00	1.00	0.85	1.00	1.00	
Fit Protected		0.99		0.95	1.00	1.00	0.95	1.00	1.00	0.95	1.00	
Satd Flow (prot)		1695		1719	1810	1538	1719	4940	1538	1719	4932	
Fit Permitted		0.90		0.95	1.00	1.00	0.95	1.00	1.00	0.95	1.00	
Satd. Flow (perm)		1548		1719	1810	1538	1719	4940	1538	1719	4932	
Peak-hour factor, PHF	0.95	0.95	0.95	0.95	0.95	0.95	0.95	0.95	0.95	0.95	0.95	0.95
Adj Flow (vph)	13	28	20	603	81	252	17	1048	465	760	2480	26
RTOR Reduction (vph)	0	0	0	0	0	0	0	0	0	0	0	0
Lane Group Flow (vph)	0	61	0	603	81	252	17	1048	465	760	2506	0
Heavy Vehicles (%)	6%	6%	6%	5%	5%	5%	5%	5%	5%	5%	5%	5%
Turn Type	Perm			Prot		pt+ov	Prot		pt+ov	Prot		
Protected Phases		8		7	4	4 5	1	6	6 7	5	2	
Permitted Phases	8											
Actuated Green, G (s)		16.0		28.0	53.0	105.3	2.4	34.3	68.4	43.3	75.8	
Effective Green, g (s)		16.0		28.0	53.0	105.3	2.4	34.3	68.4	43.3	75.8	
Actuated g/C Ratio		0.10		0.18	0.35	0.69	0.02	0.23	0.45	0.28	0.50	
Clearance Time (s)		9.0		9.0	9.0		6.1	6.1		6.7	6.1	
Vehicle Extension (s)		3.0		3.0	6.0		3.0	8.0		3.0	8.0	
Lane Grp Cap (vph)		163		316	629	1063	27	1112	690	488	2453	
v/s Ratio Prot				c0.35	0.04	0.16	0.01	0.21	0.30	c0.44	c0.51	
v/s Ratio Perm		c0.04										
v/c Ratio		0.37		1.91	0.13	0.24	0.63	0.94	0.67	1.56	1.02	
Uniform Delay, d1		63.5		62.2	33.9	8.7	74.6	58.1	33.2	54.6	38.3	
Progression Factor		1.00		1.00	1.00	1.00	1.00	1.00	1.00	1.00	1.00	
Incremental Delay, d2		6.5		420.3	0.4	0.5	38.0	16.3	2.6	260.7	23.9	
Delay (s)		70.0		482.5	34.4	9.2	112.6	74.4	35.8	315.3	62.2	
Level of Service		E		F	C	A	F	E	D	F	E	
Approach Delay (s)		70.0			316.3			63.1			121.1	
Approach LOS		E			F			E			F	

Intersection Summary

HCM Average Control Delay	136.8	HCM Level of Service	F
HCM Volume to Capacity ratio	1.29		
Actuated Cycle Length (s)	152.4	Sum of lost time (s)	24.7
Intersection Capacity Utilization	115.8%	ICU Level of Service	H
Analysis Period (min)	15		

c Critical Lane Group

HCM Signalized Intersection Capacity Analysis  
 9: Industrial Access Rd & US 41

11/15/2013

Movement	EBL	EBT	EBR	WBL	WBT	WBR	NBL	NBT	NBR	SBL	SBT	SBR
Lane Configurations												
Volume (vph)	33	55	68	702	14	68	25	1213	488	164	2549	17
Ideal Flow (vphpl)	1900	1900	1900	1900	1900	1900	1900	1900	1900	1900	1900	1900
Total Lost time (s)		6.3	6.4		6.3	6.3	6.4	6.4	6.4	6.4	6.4	6.4
Lane Util. Factor		1.00	1.00		1.00	1.00	1.00	0.91	1.00	1.00	0.91	1.00
Frt		1.00	0.85		1.00	0.85	1.00	1.00	0.85	1.00	1.00	0.85
Flt Protected		0.98	1.00		0.95	1.00	0.95	1.00	1.00	0.95	1.00	1.00
Satd. Flow (prot)		1846	1599		1776	1583	1719	4940	1538	1719	4940	1538
Flt Permitted		0.20	1.00		0.66	1.00	0.95	1.00	1.00	0.95	1.00	1.00
Satd. Flow (perm)		368	1599		1235	1583	1719	4940	1538	1719	4940	1538
Peak-hour factor, PHF	0.95	0.95	0.95	0.95	0.95	0.95	0.95	0.95	0.95	0.95	0.95	0.95
Adj. Flow (vph)	35	58	72	739	15	72	26	1277	514	173	2683	18
RTOR Reduction (vph)	0	0	1	0	0	0	0	0	277	0	0	0
Lane Group Flow (vph)	0	93	71	0	754	72	26	1277	237	173	2683	18
Heavy Vehicles (%)	1%	1%	1%	2%	2%	2%	5%	5%	5%	5%	5%	5%
Turn Type	Perm		pm+ov	Perm		Prot	Prot		Perm	Prot		Prot
Protected Phases		8	1		4	4	1	6		5	2	2
Permitted Phases	8		8	4				6				
Actuated Green, G (s)		44.8	48.8		44.8	44.8	4.0	69.1	69.1	17.0	82.1	82.1
Effective Green, g (s)		44.8	48.8		44.8	44.8	4.0	69.1	69.1	17.0	82.1	82.1
Actuated g/C Ratio		0.30	0.33		0.30	0.30	0.03	0.46	0.46	0.11	0.55	0.55
Clearance Time (s)		6.3	6.4		6.3	6.3	6.4	6.4	6.4	6.4	6.4	6.4
Vehicle Extension (s)		6.0	3.0		6.0	6.0	3.0	8.0	8.0	3.0	8.0	8.0
Lane Grp Cap (vph)		110	520		369	473	46	2276	709	195	2704	842
v/s Ratio Prot			0.00			0.05	0.02	0.26		0.10	0.54	0.01
v/s Ratio Perm	0.25	0.04		0.61					0.15			
v/c Ratio	0.85	0.14		2.04	0.15	0.57	0.56	0.33	0.89	0.99	0.02	
Uniform Delay, d1	49.4	35.7		52.6	38.6	72.1	29.4	25.8	65.6	33.6	15.5	
Progression Factor	1.00	1.00		1.00	1.00	1.00	1.00	1.00	1.00	1.00	1.00	1.00
Incremental Delay, d2	46.5	0.1		478.9	0.4	14.9	1.0	1.3	34.8	15.6	0.0	
Delay (s)	95.9	35.9		531.5	39.1	87.1	30.4	27.1	100.4	49.2	15.6	
Level of Service	F	D		F	D	F	C	C	F	D	B	
Approach Delay (s)	69.7			488.6			30.3			52.1		
Approach LOS	E			F			C			D		

Intersection Summary























HCM Average Control Delay	109.1	HCM Level of Service	F
HCM Volume to Capacity ratio	1.38		
Actuated Cycle Length (s)	150.0	Sum of lost time (s)	19.1
Intersection Capacity Utilization	114.8%	ICU Level of Service	H
Analysis Period (min)	15		

c Critical Lane Group

# HCM Signalized Intersection Capacity Analysis

## 10: Pendola Point Rd & US 41

11/15/2013

												
Movement	EBL	EBT	EBR	WBL	WBT	WBR	NBL	NBT	NBR	SBL	SBT	SBR
Lane Configurations												
Volume (vph)	134	64	14	191	0	350	3	1441	75	647	2678	8
Ideal Flow (vphpl)	1900	1900	1900	1900	1900	1900	1900	1900	1900	1900	1900	1900
Total Lost time (s)	8.1	8.1			7.1	7.1	7.5	7.5	7.5	7.5	7.5	7.5
Lane Util. Factor	1.00	1.00			1.00	0.88	1.00	0.91	1.00	0.97	0.91	1.00
Fr't	1.00	0.97			1.00	0.85	1.00	1.00	0.85	1.00	1.00	0.85
Flt Protected	0.95	1.00			0.95	1.00	0.95	1.00	1.00	0.95	1.00	1.00
Sat'd Flow (prot)	1583	1621			1656	2608	1719	4940	1538	3335	4940	1538
Flt Permitted	0.47	1.00			0.70	1.00	0.95	1.00	1.00	0.95	1.00	1.00
Sat'd Flow (perm)	775	1621			1227	2608	1719	4940	1538	3335	4940	1538
Peak-hour factor, PHF	0.95	0.95	0.95	0.95	0.95	0.95	0.95	0.95	0.95	0.95	0.95	0.95
Adj Flow (vph)	141	67	15	201	0	368	3	1517	79	681	2819	8
RTOR Reduction (vph)	0	8	0	0	0	0	0	0	41	0	0	3
Lane Group Flow (vph)	141	74	0	0	201	368	3	1517	38	681	2819	5
Heavy Vehicles (%)	14%	14%	14%	9%	9%	9%	5%	5%	5%	5%	5%	5%
Turn Type	Perm			Perm		pt+ov	Prot		Perm	Prot		Perm
Protected Phases		8			4	4 5	1	6		5	2	
Permitted Phases	8			4				6				2
Actuated Green, G (s)	18.9	18.9			19.9	53.4	0.8	47.6	47.6	26.4	73.2	73.2
Effective Green, g (s)	18.9	18.9			19.9	53.4	0.8	47.6	47.6	26.4	73.2	73.2
Actuated g/C Ratio	0.16	0.16			0.17	0.46	0.01	0.41	0.41	0.23	0.63	0.63
Clearance Time (s)	8.1	8.1			7.1		7.5	7.5	7.5	7.5	7.5	7.5
Vehicle Extension (s)	6.0	6.0			6.0		6.0	8.0	8.0	6.0	8.0	8.0
Lane Grp Cap (vph)	126	264			210	1201	12	2027	631	759	3117	971
v/s Ratio Prot		0.05				0.14	0.00	0.31		c0.20	c0.57	
v/s Ratio Perm	c0.18				0.16				0.02			0.00
v/c Ratio	1.12	0.28			0.96	0.31	0.25	0.75	0.06	0.90	0.90	0.01
Uniform Delay, d1	48.5	42.6			47.6	19.7	57.3	29.1	20.7	43.5	18.4	7.9
Progression Factor	1.00	1.00			1.00	1.00	1.00	1.00	1.00	1.00	1.00	1.00
Incremental Delay, d2	115.7	1.7			51.0	0.4	28.6	2.6	0.2	14.6	4.9	0.0
Delay (s)	164.3	44.2			98.6	20.1	85.9	31.7	20.9	58.1	23.3	7.9
Level of Service	F	D			F	C	F	C	C	E	C	A
Approach Delay (s)		120.1			47.8			31.3			30.0	
Approach LOS		F			D			C			C	

### Intersection Summary

HCM Average Control Delay	35.5	HCM Level of Service	D
HCM Volume to Capacity ratio	1.00		
Actuated Cycle Length (s)	116.0	Sum of lost time (s)	23.1
Intersection Capacity Utilization	90.7%	ICU Level of Service	E
Analysis Period (min)	15		

c Critical Lane Group

**Arterial Level of Service: NB US 41**

Cross Street	Arterial Class	Flow Speed	Running Time	Signal Delay	Travel Time (s)	Dist (mi)	Arterial Speed	Arterial LOS
Symmes Rd	II	45	162.3	54.8	217.1	2.03	33.6	B
Palm Ave.	II	40	40.6	11.7	52.3	0.42	29.1	B
Gibsonton Dr	II	40	52.7	85.5	138.2	0.59	15.2	E
Riverview Dr	II	40	93.1	30.7	123.8	1.03	30.1	B
CR 676A (Madison Ave)	II	45	222.0	35.0	257.0	2.77	38.9	A
Port Sutton Rd	II	45	34.3	6.7	41.0	0.36	31.4	B
<b>Total</b>	<b>II</b>		<b>605.0</b>	<b>224.4</b>	<b>829.4</b>	<b>7.20</b>	<b>31.3</b>	<b>B</b>

**Arterial Level of Service: SB US 41**





Cross Street	Arterial Class	Flow Speed	Running Time	Signal Delay	Travel Time (s)	Dist (mi)	Arterial Speed	Arterial LOS
Port Sutton Rd	II	45	92.6	49.7	142.3	1.16	29.3	B
Pendola Point Rd	II	45	34.3	18.7	53.0	0.36	24.3	C
Industrial Access Rd	II	45	222.0	49.1	271.1	2.77	36.8	A
Alice Ave	II	40	93.1	56.0	149.1	1.03	25.0	C
Palm Ave	II	40	52.7	20.3	73.0	0.59	28.9	B
Symmes Rd	II	40	40.6	14.9	55.5	0.42	27.4	C
<b>Total</b>	<b>II</b>		<b>535.3</b>	<b>208.7</b>	<b>744.0</b>	<b>6.33</b>	<b>30.6</b>	<b>B</b>

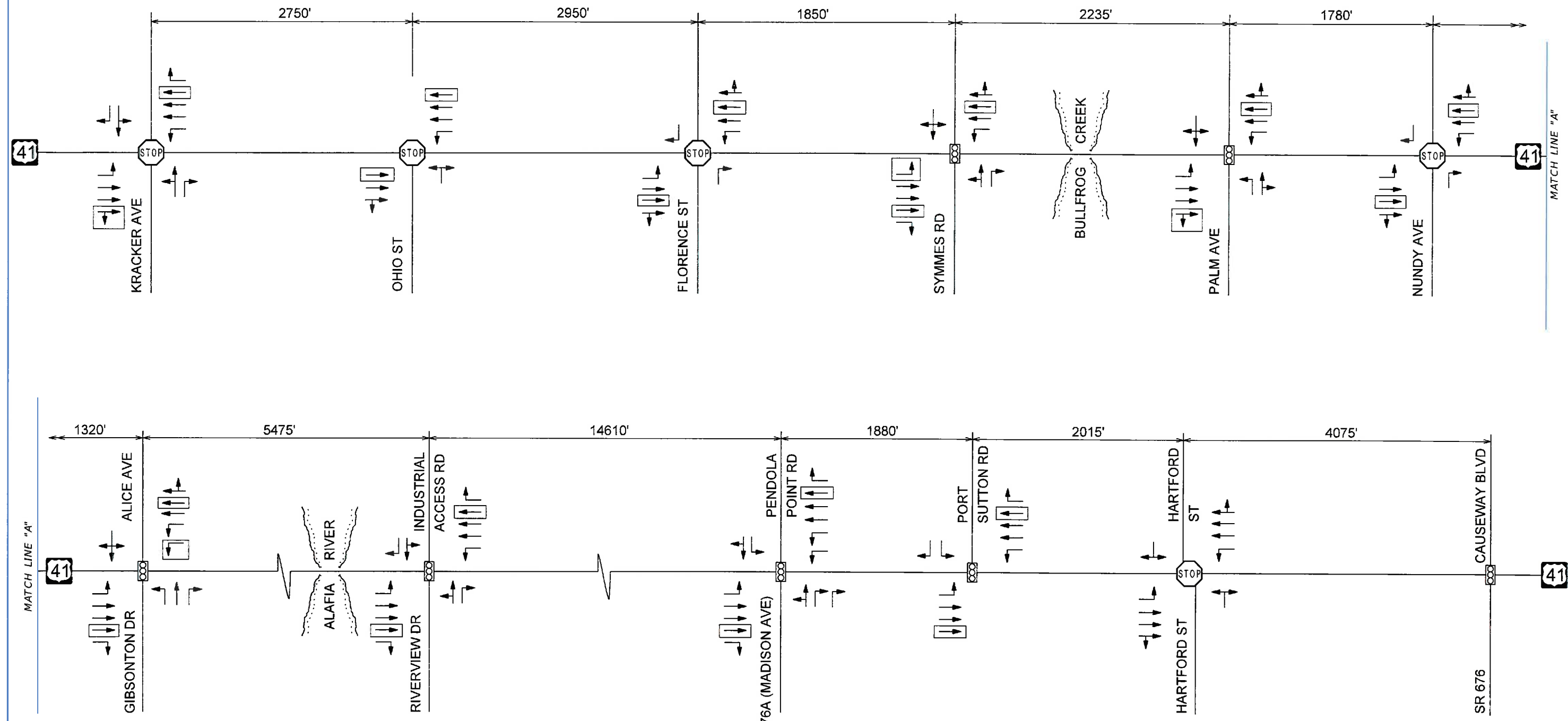

**Additional 2040 Build Analysis with FDOT  
Approved Improvements**



**Legend**

-  TRAFFIC SIGNAL
-  STOP SIGN (SIDE STREET ONLY)
-  LANES
-  DISTANCE IN FEET
-  PROPOSED ADDITIONAL LANES

NOTE:  
 NOT ALL SIDE STREETS ARE SHOWN,  
 ONLY INTERSECTIONS ANALYZED ARE SHOWN.

NOTE:  
 US 41 AT CAUSEWAY BOULEVARD HAS BEEN EVALUATED  
 FOR GRADE SEPARATION UNDER FPID: 255599-1-32-02.  
 TRAFFIC OPERATIONS ANALYSIS FOR SR 676 (CAUSEWAY  
 BOULEVARD) FROM SR 45 (US 41) TO SR 43 (US 301)

**US 41 PD&E Study**  
*From Kracker Avenue to South  
 of SR 676 (Causeway Boulevard)*  
 WPI Number: 430056-1  
 Hillsborough County

**FDOT Approved Lane Geometry**

TWO-WAY STOP CONTROL SUMMARY

Analyst: AG  
 Agency/Co.: American  
 Date Performed: 06/17/2013  
 Analysis Time Period: AM Peak  
 Intersection: Kracker Avenue & US 41  
 Jurisdiction: FDOT D7  
 Units: U. S. Customary  
 Analysis Year: 2040 Build  
 Project ID: US 41 PD&E Study  
 East/West Street: Kracker Ave  
 North/South Street: US 41  
 Intersection Orientation: NS Study period (hrs): 0.25

Vehicle Volumes and Adjustments

Major Street:	Approach Movement	Northbound			Southbound		
		1 L	2 T	3 R	4 L	5 T	6 R
Volume		9	1622	11	2	899	4
Peak-Hour Factor, PHF		0.95	0.95	0.95	0.95	0.95	0.95
Hourly Flow Rate, HFR		9	1707	11	2	946	4
Percent Heavy Vehicles		5	--	--	5	--	--
Median Type/Storage		Raised curb			/ 1		
RT Channelized?					No		
Lanes		1	2	0	1	2	1
Configuration		L	T	TR	L	T	R
Upstream Signal?		No			No		

Minor Street:	Approach Movement	Westbound			Eastbound		
		7 L	8 T	9 R	10 L	11 T	12 R
Volume		25	0	9	8	0	13
Peak Hour Factor, PHF		0.95	0.95	0.95	0.95	0.95	0.95
Hourly Flow Rate, HFR		26	0	9	8	0	13
Percent Heavy Vehicles		0	0	0	0	0	0
Percent Grade (%)		0			0		
Flared Approach: Exists?/Storage					/		
Lanes		0	1	1	0	1	1
Configuration		LT		R	LT		R

Delay, Queue Length, and Level of Service

Approach Movement	NB	SB	Westbound			Eastbound		
			7 LT	8 R	9 R	10 LT	11 R	12 R
Lane Config	L	L	LT	R	R	LT	R	R
v (vph)	9	2	26		9	8		13
C(m) (vph)	700	352	77		359	154		595
v/c	0.01	0.01	0.34		0.03	0.05		0.02
95% queue length	0.04	0.02	1.27		0.08	0.16		0.07
Control Delay	10.2	15.3	73.9		15.3	29.7		11.2
LOS	B	C	F		C	D		B
Approach Delay				58.9				18.2
Approach LOS				F				C

## TWO-WAY STOP CONTROL SUMMARY

Analyst: AG  
 Agency/Co.: American  
 Date Performed: 06/17/2013  
 Analysis Time Period: AM Peak  
 Intersection: Ohio Street & US 41  
 Jurisdiction: FDOT D7  
 Units: U. S. Customary  
 Analysis Year: 2040 Build  
 Project ID: US 41 PD&E Study  
 East/West Street: Ohio St  
 North/South Street: US 41  
 Intersection Orientation: NS

Study period (hrs): 0.25

## Vehicle Volumes and Adjustments

Major Street:	Approach Movement	Northbound			Southbound		
		1 L	2 T	3 R	4 L	5 T	6 R
Volume		1608	23		79	779	
Peak-Hour Factor, PHF		0.95	0.95		0.95	0.95	
Hourly Flow Rate, HFR		1692	24		83	820	
Percent Heavy Vehicles		--	--		5	--	--
Median Type/Storage		Raised curb			/ 1		
RT Channelized?							
Lanes		2	0		1	2	
Configuration		T	TR		L	T	
Upstream Signal?		No				No	

Minor Street:	Approach Movement	Westbound			Eastbound		
		7 L	8 T	9 R	10 L	11 T	12 R
Volume		43		43			
Peak Hour Factor, PHF		0.95		0.95			
Hourly Flow Rate, HFR		45		45			
Percent Heavy Vehicles		16		16			
Percent Grade (%)			0			0	
Flared Approach: Exists?/Storage				No	/		/
Lanes		0		0			
Configuration			LR				

## Delay, Queue Length, and Level of Service

Approach Movement	NB 1	SB 4	Westbound			Eastbound		
			7	8	9	10	11	12
Lane Config		L		LR				
v (vph)		83		90				
C(m) (vph)		352		136				
v/c		0.24		0.66				
95% queue length		0.90		3.61				
Control Delay		18.4		72.3				
LOS		C		F				
Approach Delay				72.3				
Approach LOS				F				

TWO-WAY STOP CONTROL SUMMARY

Analyst: AG  
 Agency/Co.: American  
 Date Performed: 06/17/2013  
 Analysis Time Period: AM Peak  
 Intersection: Florence St & US 41  
 Jurisdiction: FDOT D7  
 Units: U. S. Customary  
 Analysis Year: 2040 Build  
 Project ID: US 41 PD&E Study  
 East/West Street: Florence St  
 North/South Street: US 41  
 Intersection Orientation: NS Study period (hrs): 0.25

Vehicle Volumes and Adjustments

Major Street: Approach Movement	Northbound			Southbound		
	1 L	2 T	3 R	4 L	5 T	6 R
Volume	8	1491	0	4	819	22
Peak-Hour Factor, PHF	0.95	0.95	0.95	0.95	0.95	0.95
Hourly Flow Rate, HFR	8	1569	0	4	862	23
Percent Heavy Vehicles	5	--	--	5	--	--
Median Type/Storage	Raised curb			/ 1		
RT Channelized?						
Lanes Configuration	1 L	2 T	0 TR	1 L	2 T	0 TR
Upstream Signal?	No			No		





















Minor Street: Approach Movement	Westbound			Eastbound		
	7 L	8 T	9 R	10 L	11 T	12 R
Volume	26			28		
Peak Hour Factor, PHF	0.95			0.95		
Hourly Flow Rate, HFR	27			29		
Percent Heavy Vehicles	0			0		
Percent Grade (%)	0			0		
Flared Approach: Exists?/Storage	/			/		
Lanes Configuration	1 R			1 R		

Delay, Queue Length, and Level of Service

Approach Movement Lane Config	NB	SB	Westbound			Eastbound			
	1 L	4 L	7 	8	9 R	10 	11	12 R	
v (vph)	8	4	27			29			
C(m) (vph)	742	403	396			620			
v/c	0.01	0.01	0.07			0.05			
95% queue length	0.03	0.03	0.22			0.15			
Control Delay	9.9	14.0	14.8			11.1			
LOS	A	B	B			B			
Approach Delay	14.8			11.1					
Approach LOS	B			B					

HCM Signalized Intersection Capacity Analysis  
 35: US 41 & Symmes Rd

5/3/2016

												
Movement	EBL	EBT	EBR	WBL	WBT	WBR	NBL	NBT	NBR	SBL	SBT	SBR
Lane Configurations												
Volume (vph)	1	0	0	311	0	728	17	2019	218	211	1236	0
Ideal Flow (vphpl)	1900	1900	1900	1900	1900	1900	1900	1900	1900	1900	1900	1900
Total Lost time (s)		7.2			7.2	7.2	6.2	6.2	7.2	7.0	6.2	
Lane Util. Factor		1.00			1.00	1.00	1.00	0.91	1.00	1.00	0.91	
Frt		1.00			1.00	0.85	1.00	1.00	0.85	1.00	1.00	
Flt Protected		0.95			0.95	1.00	0.95	1.00	1.00	0.95	1.00	
Satd. Flow (prot)		1805			1703	1524	1719	4940	1538	1719	4940	
Flt Permitted		0.56			0.97	1.00	0.95	1.00	1.00	0.95	1.00	
Satd. Flow (perm)		1070			1731	1524	1719	4940	1538	1719	4940	
Peak-hour factor, PHF	0.95	0.95	0.95	0.95	0.95	0.95	0.95	0.95	0.95	0.95	0.95	0.95
Adj. Flow (vph)	1	0	0	327	0	766	18	2125	229	222	1301	0
RTOR Reduction (vph)	0	0	0	0	0	0	0	0	77	0	0	0
Lane Group Flow (vph)	0	1	0	0	327	766	18	2125	152	222	1301	0
Heavy Vehicles (%)	0%	0%	0%	6%	6%	6%	5%	5%	5%	5%	5%	5%
Turn Type	Perm	NA		Perm	NA	Perm	Prot	NA	custom	Prot	NA	
Protected Phases		8			4		1	6	7	5	2	
Permitted Phases	8			4		4			6			
Actuated Green, G (s)		9.3			65.5	65.5	3.5	56.2	105.2	16.0	69.5	
Effective Green, g (s)		9.3			65.5	65.5	3.5	56.2	105.2	16.0	69.5	
Actuated g/C Ratio		0.06			0.41	0.41	0.02	0.36	0.67	0.10	0.44	
Clearance Time (s)		7.2			7.2	7.2	6.2	6.2	7.2	7.0	6.2	
Vehicle Extension (s)		3.0			3.0	3.0	3.0	4.0	3.0	3.0	4.0	
Lane Grp Cap (vph)		62			717	631	38	1756	1023	173	2171	
v/s Ratio Prot							0.01	c0.43	0.05	c0.13	0.26	
v/s Ratio Perm		0.00			0.19	c0.50			0.05			
v/c Ratio		0.02			0.46	1.21	0.47	1.21	0.15	1.28	0.60	
Uniform Delay, d1		70.1			33.4	46.3	76.4	50.9	9.8	71.0	33.7	
Progression Factor		1.00			1.00	1.00	1.00	1.00	1.00	1.00	1.00	
Incremental Delay, d2		0.1			0.5	110.4	9.0	100.1	0.1	164.1	0.5	
Delay (s)		70.2			33.9	156.7	85.4	151.1	9.9	235.1	34.2	
Level of Service		E			C	F	F	F	A	F	C	
Approach Delay (s)		70.2			120.0			137.0			63.5	
Approach LOS		E			F			F			E	

Intersection Summary

HCM 2000 Control Delay	110.8	HCM 2000 Level of Service	F
HCM 2000 Volume to Capacity ratio	1.29		
Actuated Cycle Length (s)	158.1	Sum of lost time (s)	27.6
Intersection Capacity Utilization	107.1%	ICU Level of Service	G
Analysis Period (min)	15		

c Critical Lane Group

# HCM Signalized Intersection Capacity Analysis

## 46: US 41 & Palm Ave.

5/3/2016

Movement	EBL	EBT	EBR	WBL	WBT	WBR	NBL	NBT	NBR	SBL	SBT	SBR
Lane Configurations		↕		↗	↘		↗	↕		↗	↕	↘
Volume (vph)	49	0	22	4	0	29	5	2589	9	41	1391	7
Ideal Flow (vphpl)	1900	1900	1900	1900	1900	1900	1900	1900	1900	1900	1900	1900
Total Lost time (s)		6.7		6.7	6.7		6.2	6.2		6.5	6.2	
Lane Util. Factor		1.00		1.00	1.00		1.00	0.91		1.00	0.91	
Frt		0.96		1.00	0.85		1.00	1.00		1.00	1.00	
Flt Protected		0.97		0.95	1.00		0.95	1.00		0.95	1.00	
Satd. Flow (prot)		1760		1805	1615		1719	4938		1719	4936	
Flt Permitted		0.77		0.71	1.00		0.95	1.00		0.95	1.00	
Satd. Flow (perm)		1409		1346	1615		1719	4938		1719	4936	
Peak-hour factor, PHF	0.95	0.95	0.95	0.95	0.95	0.95	0.95	0.95	0.95	0.95	0.95	0.95
Adj. Flow (vph)	52	0	23	4	0	31	5	2725	9	43	1464	7
RTOR Reduction (vph)	0	0	0	0	0	0	0	0	0	0	0	0
Lane Group Flow (vph)	0	75	0	4	31	0	5	2734	0	43	1471	0
Heavy Vehicles (%)	0%	0%	0%	0%	0%	0%	5%	5%	5%	5%	5%	5%
Turn Type	Perm	NA		Perm	NA		Prot	NA		Prot	NA	
Protected Phases		8			4		1	6		5	2	
Permitted Phases	8			4								
Actuated Green, G (s)		9.8		9.8	9.8		5.4	50.1		2.8	47.8	
Effective Green, g (s)		9.8		9.8	9.8		5.4	50.1		2.8	47.8	
Actuated g/C Ratio		0.12		0.12	0.12		0.07	0.61		0.03	0.58	
Clearance Time (s)		6.7		6.7	6.7		6.2	6.2		6.5	6.2	
Vehicle Extension (s)		3.0		3.0	3.0		4.0	4.0		2.5	4.0	
Lane Grp Cap (vph)		168		160	192		113	3013		58	2873	
v/s Ratio Prot					0.02		0.00	c0.55		c0.03	0.30	
v/s Ratio Perm		c0.05		0.00								
v/c Ratio		0.45		0.03	0.16		0.04	0.91		0.74	0.51	
Uniform Delay, d1		33.6		31.9	32.5		35.9	14.0		39.3	10.2	
Progression Factor		1.00		1.00	1.00		1.00	1.00		1.00	1.00	
Incremental Delay, d2		1.9		0.1	0.4		0.2	4.5		37.9	0.2	
Delay (s)		35.5		32.0	32.9		36.2	18.5		77.2	10.4	
Level of Service		D		C	C		D	B		E	B	
Approach Delay (s)		35.5			32.8			18.5			12.3	
Approach LOS		D			C			B			B	
<b>Intersection Summary</b>												
HCM 2000 Control Delay			16.8			HCM 2000 Level of Service			B			
HCM 2000 Volume to Capacity ratio			0.83									
Actuated Cycle Length (s)			82.1			Sum of lost time (s)		19.4				
Intersection Capacity Utilization			71.7%			ICU Level of Service			C			
Analysis Period (min)			15									
c Critical Lane Group												

TWO-WAY STOP CONTROL SUMMARY

Analyst: AG  
 Agency/Co.: American  
 Date Performed: 06/17/2013  
 Analysis Time Period: AM Peak  
 Intersection: Nundy Ave & US 41  
 Jurisdiction: FDOT D7  
 Units: U. S. Customary  
 Analysis Year: 2040 Build  
 Project ID: US 41 PD&E Study  
 East/West Street: Nundy Ave  
 North/South Street: US 41  
 Intersection Orientation: NS Study period (hrs): 0.25

Vehicle Volumes and Adjustments

Major Street:	Approach Movement	Northbound			Southbound		
		1 L	2 T	3 R	4 L	5 T	6 R
Volume		16	1697	27	41	938	5
Peak-Hour Factor, PHF		0.95	0.95	0.95	0.95	0.95	0.95
Hourly Flow Rate, HFR		16	1786	28	43	987	5
Percent Heavy Vehicles		5	--	--	5	--	--
Median Type/Storage		Raised curb			/ 1		
RT Channelized?							
Lanes		1	2	0	1	2	0
Configuration		L	T	TR	L	T	TR
Upstream Signal?		No			Yes		

Minor Street:	Approach Movement	Westbound			Eastbound		
		7 L	8 T	9 R	10 L	11 T	12 R
Volume				190			23
Peak Hour Factor, PHF				0.95			0.95
Hourly Flow Rate, HFR				200			24
Percent Heavy Vehicles				10			0
Percent Grade (%)		0			0		
Flared Approach: Exists?/Storage					/		
Lanes				1			1
Configuration				R			R























Delay, Queue Length, and Level of Service

Approach Movement	NB	SB	Westbound			Eastbound		
			7	8	9	10	11	12
Lane Config	L	L			R			R
v (vph)	16	43			200			24
C(m) (vph)	993	322			314			677
v/c	0.02	0.13			0.64			0.04
95% queue length	0.05	0.46			4.09			0.11
Control Delay	8.7	17.9			34.6			10.5
LOS	A	C			D			B
Approach Delay					34.6			10.5
Approach LOS					D			B

























HCM Signalized Intersection Capacity Analysis  
 40: US 41 & Alice Ave/Gibsonton Dr

5/3/2016

													
Movement	EBL	EBT	EBR	WBL	WBT	WBR	NBL	NBT	NBR	SBL	SBT	SBR	
Lane Configurations													
Volume (vph)	21	38	9	499	99	771	17	2281	318	358	1341	26	
Ideal Flow (vphpl)	1900	1900	1900	1900	1900	1900	1900	1900	1900	1900	1900	1900	
Total Lost time (s)		9.0		9.0	9.0	9.0	6.1	6.1	6.1	6.7	6.1		
Lane Util. Factor		1.00		1.00	1.00	1.00	1.00	0.91	1.00	0.97	0.91		
Frt		0.98		1.00	1.00	0.85	1.00	1.00	0.85	1.00	1.00		
Flt Protected		0.98		0.95	1.00	1.00	0.95	1.00	1.00	0.95	1.00		
Satd. Flow (prot)		1839		1703	1792	1524	1719	4940	1538	3335	4926		
Flt Permitted		0.86		0.95	1.00	1.00	0.95	1.00	1.00	0.95	1.00		
Satd. Flow (perm)		1601		1703	1792	1524	1719	4940	1538	3335	4926		
Peak-hour factor, PHF	0.95	0.95	0.95	0.95	0.95	0.95	0.95	0.95	0.95	0.95	0.95	0.95	
Adj. Flow (vph)	22	40	9	525	104	812	18	2401	335	377	1412	27	
RTOR Reduction (vph)	0	0	0	0	0	0	0	0	0	0	0	0	
Lane Group Flow (vph)	0	71	0	525	104	812	18	2401	335	377	1439	0	
Heavy Vehicles (%)	0%	0%	0%	6%	6%	6%	5%	5%	5%	5%	5%	5%	
Turn Type	Perm	NA		Prot	NA	pt+ov	Prot	NA	pt+ov	Prot	NA		
Protected Phases		8		7	4	4 5	1	6	6 7	5	2		
Permitted Phases	8												
Actuated Green, G (s)		16.0		33.0	58.0	80.3	3.5	59.3	98.4	13.3	69.7		
Effective Green, g (s)		16.0		33.0	58.0	80.3	3.5	59.3	98.4	13.3	69.7		
Actuated g/C Ratio		0.10		0.22	0.38	0.53	0.02	0.39	0.65	0.09	0.46		
Clearance Time (s)		9.0		9.0	9.0		6.1	6.1		6.7	6.1		
Vehicle Extension (s)		3.0		3.0	6.0		3.0	8.0		3.0	8.0		
Lane Grp Cap (vph)		168		368	681	803	39	1922	993	291	2252		
v/s Ratio Prot				c0.31	0.06	c0.53	0.01	c0.49	0.22	c0.11	0.29		
v/s Ratio Perm		0.04											
v/c Ratio		0.42		1.43	0.15	1.01	0.46	1.25	0.34	1.30	0.64		
Uniform Delay, d1		63.9		59.7	31.0	36.1	73.5	46.6	12.2	69.5	31.7		
Progression Factor		1.00		1.00	1.00	1.00	1.00	1.00	1.00	1.00	1.00		
Incremental Delay, d2		7.6		207.1	0.5	34.6	8.4	116.7	0.2	156.1	1.4		
Delay (s)		71.5		266.8	31.5	70.6	81.9	163.2	12.4	225.6	33.1		
Level of Service		E		F	C	E	F	F	B	F	C		
Approach Delay (s)		71.5			139.3			144.3			73.1		
Approach LOS		E			F			F			E		
<b>Intersection Summary</b>													
HCM 2000 Control Delay			121.0		HCM 2000 Level of Service					F			
HCM 2000 Volume to Capacity ratio			1.35										
Actuated Cycle Length (s)			152.4	Sum of lost time (s)					30.8				
Intersection Capacity Utilization			117.7%	ICU Level of Service					H				
Analysis Period (min)			15										
c Critical Lane Group													

HCM Signalized Intersection Capacity Analysis  
 9: US 41 & Industrial Access Rd/Riverview Dr

5/3/2016























												
Movement	EBL	EBT	EBR	WBL	WBT	WBR	NBL	NBT	NBR	SBL	SBT	SBR
Lane Configurations												
Volume (vph)	11	16	24	589	65	402	98	2714	291	28	1441	49
Ideal Flow (vphpl)	1900	1900	1900	1900	1900	1900	1900	1900	1900	1900	1900	1900
Total Lost time (s)		6.3	6.4		6.3	6.3	6.4	6.4	6.4	6.4	6.4	6.4
Lane Util. Factor		1.00	1.00		1.00	1.00	1.00	0.91	1.00	1.00	0.91	1.00
Frt		1.00	0.85		1.00	0.85	1.00	1.00	0.85	1.00	1.00	0.85
Flt Protected		0.98	1.00		0.96	1.00	0.95	1.00	1.00	0.95	1.00	1.00
Satd. Flow (prot)		1633	1417		1715	1524	1719	4940	1538	1719	4940	1538
Flt Permitted		0.43	1.00		0.73	1.00	0.95	1.00	1.00	0.95	1.00	1.00
Satd. Flow (perm)		713	1417		1302	1524	1719	4940	1538	1719	4940	1538
Peak-hour factor, PHF	0.95	0.95	0.95	0.95	0.95	0.95	0.95	0.95	0.95	0.95	0.95	0.95
Adj. Flow (vph)	12	17	25	620	68	423	103	2857	306	29	1517	52
RTOR Reduction (vph)	0	0	16	0	0	0	0	0	75	0	0	0
Lane Group Flow (vph)	0	29	9	0	688	423	103	2857	231	29	1517	52
Heavy Vehicles (%)	14%	14%	14%	6%	6%	6%	5%	5%	5%	5%	5%	5%
Turn Type	Perm	NA	pm+ov	Perm	NA	Prot	Prot	NA	Perm	Prot	NA	Prot
Protected Phases		8	1		4	4	1	6		5	2	2
Permitted Phases	8		8	4					6			
Actuated Green, G (s)		43.5	55.5		43.5	43.5	12.0	84.8	84.8	3.2	76.0	76.0
Effective Green, g (s)		43.5	55.5		43.5	43.5	12.0	84.8	84.8	3.2	76.0	76.0
Actuated g/C Ratio		0.29	0.37		0.29	0.29	0.08	0.56	0.56	0.02	0.50	0.50
Clearance Time (s)		6.3	6.4		6.3	6.3	6.4	6.4	6.4	6.4	6.4	6.4
Vehicle Extension (s)		6.0	3.0		6.0	6.0	3.0	8.0	8.0	3.0	8.0	8.0
Lane Grp Cap (vph)		205	522		376	440	136	2781	866	36	2492	776
v/s Ratio Prot			0.00			0.28	c0.06	c0.58		0.02	0.31	0.03
v/s Ratio Perm		0.04	0.01		c0.53				0.15			
v/c Ratio		0.14	0.02		1.83	0.96	0.76	1.03	0.27	0.81	0.61	0.07
Uniform Delay, d1		39.7	30.2		53.5	52.7	67.9	32.9	16.9	73.4	26.7	19.1
Progression Factor		1.00	1.00		1.00	1.00	1.00	1.00	1.00	1.00	1.00	1.00
Incremental Delay, d2		0.9	0.0		383.7	33.8	21.1	24.5	0.8	75.6	1.1	0.2
Delay (s)		40.6	30.2		437.2	86.5	89.0	57.4	17.7	149.0	27.8	19.3
Level of Service		D	C		F	F	F	E	B	F	C	B
Approach Delay (s)		35.8			303.7			54.7			29.7	
Approach LOS		D			F			D			C	

Intersection Summary			
HCM 2000 Control Delay	93.8	HCM 2000 Level of Service	F
HCM 2000 Volume to Capacity ratio	1.31		
Actuated Cycle Length (s)	150.6	Sum of lost time (s)	19.1
Intersection Capacity Utilization	114.4%	ICU Level of Service	H
Analysis Period (min)	15		

c Critical Lane Group

HCM Signalized Intersection Capacity Analysis  
 10: US 41 & Pendola Point Rd/CR 676A (Madison Ave)

5/3/2016

												
Movement	EBL	EBT	EBR	WBL	WBT	WBR	NBL	NBT	NBR	SBL	SBT	SBR
Lane Configurations												
Volume (vph)	65	11	26	133	32	921	20	2628	82	485	1279	89
Ideal Flow (vphpl)	1900	1900	1900	1900	1900	1900	1900	1900	1900	1900	1900	1900
Total Lost time (s)	8.1	8.1			7.1	7.1	7.5	7.5	7.5	7.5	7.5	7.5
Lane Util. Factor	1.00	1.00			1.00	0.88	1.00	0.91	1.00	0.97	0.91	1.00
Fr <sub>t</sub>	1.00	0.90			1.00	0.85	1.00	1.00	0.85	1.00	1.00	0.85
Fl <sub>t</sub> Protected	0.95	1.00			0.96	1.00	0.95	1.00	1.00	0.95	1.00	1.00
Satd. Flow (prot)	1157	1091			1660	2584	1719	4940	1538	3335	4940	1538
Fl <sub>t</sub> Permitted	0.47	1.00			0.74	1.00	0.95	1.00	1.00	0.95	1.00	1.00
Satd. Flow (perm)	570	1091			1280	2584	1719	4940	1538	3335	4940	1538
Peak-hour factor, PHF	0.95	0.95	0.95	0.95	0.95	0.95	0.95	0.95	0.95	0.95	0.95	0.95
Adj. Flow (vph)	68	12	27	140	34	969	21	2766	86	511	1346	94
RTOR Reduction (vph)	0	23	0	0	0	21	0	0	39	0	0	31
Lane Group Flow (vph)	68	16	0	0	174	948	21	2766	47	511	1346	63
Heavy Vehicles (%)	56%	56%	56%	10%	10%	10%	5%	5%	5%	5%	5%	5%
Turn Type	Perm	NA		Perm	NA	pt+ov	Prot	NA	Perm	Prot	NA	Perm
Protected Phases		8			4	4 5	1	6		5	2	
Permitted Phases	8			4					6			2
Actuated Green, G (s)	23.9	23.9			24.9	53.7	3.7	84.3	84.3	21.7	102.3	102.3
Effective Green, g (s)	23.9	23.9			24.9	53.7	3.7	84.3	84.3	21.7	102.3	102.3
Actuated g/C Ratio	0.16	0.16			0.16	0.35	0.02	0.55	0.55	0.14	0.67	0.67
Clearance Time (s)	8.1	8.1			7.1		7.5	7.5	7.5	7.5	7.5	7.5
Vehicle Extension (s)	6.0	6.0			6.0		3.0	8.0	8.0	6.0	8.0	8.0
Lane Grp Cap (vph)	89	170			208	906	41	2721	847	473	3303	1028
v/s Ratio Prot		0.01				c0.37	0.01	c0.56		c0.15	0.27	
v/s Ratio Perm	0.12				0.14				0.03			0.04
v/c Ratio	0.76	0.10			0.84	1.05	0.51	1.02	0.06	1.08	0.41	0.06
Uniform Delay, d <sub>1</sub>	61.8	55.3			62.1	49.6	73.8	34.4	15.9	65.7	11.5	8.8
Progression Factor	1.00	1.00			1.00	1.00	1.00	1.00	1.00	1.00	1.00	1.00
Incremental Delay, d <sub>2</sub>	38.9	0.7			27.6	42.6	10.4	21.5	0.1	64.7	0.4	0.1
Delay (s)	100.8	56.0			89.7	92.3	84.1	55.9	16.0	130.4	11.9	8.9
Level of Service	F	E			F	F	F	E	B	F	B	A
Approach Delay (s)		84.4			91.9			54.9			42.8	
Approach LOS		F			F			D			D	

Intersection Summary			
HCM 2000 Control Delay	58.5	HCM 2000 Level of Service	E
HCM 2000 Volume to Capacity ratio	1.09		
Actuated Cycle Length (s)	153.0	Sum of lost time (s)	23.1
Intersection Capacity Utilization	106.9%	ICU Level of Service	G
Analysis Period (min)	15		

c Critical Lane Group

# HCM Signalized Intersection Capacity Analysis

## 17: US 41 & Port Sutton Rd

5/3/2016



Movement	EBL	EBR	NBL	NBT	SBU	SBT	SBR
Lane Configurations							
Volume (vph)	56	20	38	3295	10	1831	129
Ideal Flow (vphpl)	1900	1900	1900	1900	1900	1900	1900
Total Lost time (s)	7.7	7.0	7.0	6.7	6.4	6.7	7.7
Lane Util. Factor	1.00	1.00	1.00	0.91	1.00	0.91	1.00
Fr <sub>t</sub>	1.00	0.85	1.00	1.00	1.00	1.00	0.85
Fl <sub>t</sub> Protected	0.95	1.00	0.95	1.00	0.95	1.00	1.00
Satd. Flow (prot)	1271	1137	1719	4940	1719	4940	1538
Fl <sub>t</sub> Permitted	0.95	1.00	0.95	1.00	0.95	1.00	1.00
Satd. Flow (perm)	1271	1137	1719	4940	1719	4940	1538
Peak-hour factor, PHF	0.95	0.95	0.95	0.95	0.95	0.95	0.95
Adj. Flow (vph)	59	21	40	3468	11	1927	136
RTOR Reduction (vph)	0	18	0	0	0	0	27
Lane Group Flow (vph)	59	3	40	3468	11	1927	109
Heavy Vehicles (%)	42%	42%	5%	5%	5%	5%	5%
Turn Type	Prot	pm+ov	Prot	NA	Prot	NA	pm+ov
Protected Phases	8	1	1	6	5	2	8
Permitted Phases		8					2
Actuated Green, G (s)	13.6	20.2	6.6	102.5	1.9	97.2	110.8
Effective Green, g (s)	13.6	20.2	6.6	102.5	1.9	97.2	110.8
Actuated g/C Ratio	0.10	0.15	0.05	0.74	0.01	0.70	0.80
Clearance Time (s)	7.7	7.0	7.0	6.7	6.4	6.7	7.7
Vehicle Extension (s)	6.0	3.0	3.0	8.0	3.0	8.0	6.0
Lane Grp Cap (vph)	124	165	81	3648	23	3459	1227
v/s Ratio Prot	c0.05	0.00	c0.02	c0.70	0.01	0.39	0.01
v/s Ratio Perm		0.00					0.06
v/c Ratio	0.48	0.02	0.49	0.95	0.48	0.56	0.09
Uniform Delay, d1	59.2	50.8	64.5	15.9	68.0	10.2	3.0
Progression Factor	1.00	1.00	1.00	1.00	1.00	1.00	1.00
Incremental Delay, d2	7.9	0.0	4.7	7.2	14.8	0.7	0.1
Delay (s)	67.1	50.9	69.1	23.1	82.8	10.9	3.1
Level of Service	E	D	E	C	F	B	A
Approach Delay (s)	62.9			23.6		10.7	
Approach LOS	E			C		B	

Intersection Summary			
HCM 2000 Control Delay	19.5	HCM 2000 Level of Service	B
HCM 2000 Volume to Capacity ratio	0.91		
Actuated Cycle Length (s)	138.8	Sum of lost time (s)	21.4
Intersection Capacity Utilization	81.5%	ICU Level of Service	D
Analysis Period (min)	15		
c Critical Lane Group			

TWO-WAY STOP CONTROL SUMMARY

Analyst: AG  
 Agency/Co.: American  
 Date Performed: 06/17/2013  
 Analysis Time Period: AM Peak  
 Intersection: Hartford St & US 41  
 Jurisdiction: FDOT D7  
 Units: U. S. Customary  
 Analysis Year: 2040 Build  
 Project ID: US 41 PD&E Study  
 East/West Street: Hartford St  
 North/South Street: US 41  
 Intersection Orientation: NS Study period (hrs): 0.25

Vehicle Volumes and Adjustments

Major Street: Approach Movement	Northbound			Southbound		
	1 L	2 T	3 R	4 L	5 T	6 R
Volume	14	2323	27	113	1370	37
Peak-Hour Factor, PHF	0.95	0.95	0.95	0.95	0.95	0.95
Hourly Flow Rate, HFR	14	2445	28	118	1442	38
Percent Heavy Vehicles	5	--	--	5	--	--
Median Type/Storage	Raised curb			/ 1		
RT Channelized?						
Lanes Configuration	1 L	2 T	0 TR	1 L	2 T	0 TR
Upstream Signal?	No			No		

Minor Street: Approach Movement	Westbound			Eastbound		
	7 L	8 T	9 R	10 L	11 T	12 R
Volume	24	0	121	5	0	3
Peak Hour Factor, PHF	0.95	0.95	0.95	0.95	0.95	0.95
Hourly Flow Rate, HFR	25	0	127	5	0	3
Percent Heavy Vehicles	27	27	27	0	0	0
Percent Grade (%)	0					
Flared Approach: Exists?/Storage			No	/	No /	
Lanes Configuration	0	1 LTR	0	0	1 LTR	0

Delay, Queue Length, and Level of Service

Approach Movement Lane Config	NB	SB	Westbound			Eastbound		
	1 L	4 L	7	8 LTR	9	10	11 LTR	12
v (vph)	14	118	152			8		
C(m) (vph)	436	176				0		
v/c	0.03	0.67						
95% queue length	0.10	3.95						
Control Delay	13.5	59.3						
LOS	B	F				F		
Approach Delay								
Approach LOS								

Arterial Level of Service: NB US 41

Cross Street	Arterial Class	Flow Speed	Running Time	Signal Delay	Travel Time (s)	Dist (mi)	Arterial Speed	Arterial LOS
Symmes Rd	II	45	162.3	137.4	299.7	2.03	24.4	C
Palm Ave.	II	40	40.6	18.5	59.1	0.42	25.7	C
Gibsonton Dr	II	40	52.7	169.7	222.4	0.59	9.5	F
Riverview Dr	II	40	93.1	53.9	147.0	1.03	25.3	C
CR 676A (Madison Ave	II	45	222.0	60.5	282.5	2.77	35.4	A
Port Sutton Rd	II	45	34.3	20.0	54.3	0.36	23.7	C
Total	II		605.0	460.0	1065.0	7.20	24.3	C

Arterial Level of Service: SB US 41

Cross Street	Arterial Class	Flow Speed	Running Time	Signal Delay	Travel Time (s)	Dist (mi)	Arterial Speed	Arterial LOS
Port Sutton Rd	II	45	92.6	11.4	104.0	1.16	40.0	A
Pendola Point Rd	II	45	34.3	11.4	45.7	0.36	28.2	B
Industrial Access Rd	II	45	222.0	28.4	250.4	2.77	39.9	A
Alice Ave	II	40	93.1	32.7	125.8	1.03	29.6	B
Palm Ave.	II	40	52.7	11.6	64.3	0.59	32.8	B
Symmes Rd	II	40	40.6	31.2	71.8	0.42	21.2	D
Total	II		535.3	126.7	662.0	6.33	34.4	B

TWO-WAY STOP CONTROL SUMMARY

Analyst: AG  
 Agency/Co.: American  
 Date Performed: 06/17/2013  
 Analysis Time Period: PM Peak  
 Intersection: Kracker Avenue & US 41  
 Jurisdiction: FDOT D7  
 Units: U. S. Customary  
 Analysis Year: 2040 Build  
 Project ID: US 41 PD&E Study  
 East/West Street: Kracker Ave  
 North/South Street: US 41  
 Intersection Orientation: NS Study period (hrs): 0.25

Vehicle Volumes and Adjustments

Major Street:	Approach Movement	Northbound			Southbound		
		1 L	2 T	3 R	4 L	5 T	6 R
Volume		10	893	14	7	1615	5
Peak-Hour Factor, PHF		0.95	0.95	0.95	0.95	0.95	0.95
Hourly Flow Rate, HFR		10	940	14	7	1700	5
Percent Heavy Vehicles		5	--	--	5	--	--
Median Type/Storage		Raised curb			/ 1		
RT Channelized?					No		
Lanes		1	2	0	1	2	1
Configuration		L	T	TR	L	T	R
Upstream Signal?		No			No		

Minor Street:	Approach Movement	Westbound			Eastbound		
		7 L	8 T	9 R	10 L	11 T	12 R
Volume		14	2	14	6	0	6
Peak Hour Factor, PHF		0.95	0.95	0.95	0.95	0.95	0.95
Hourly Flow Rate, HFR		14	2	14	6	0	6
Percent Heavy Vehicles		15	15	15	0	0	0
Percent Grade (%)		0			0		
Flared Approach: Exists?/Storage					/		
Lanes		0	1	1	0	1	1
Configuration		LT		R	LT		R

Delay, Queue Length, and Level of Service

Approach Movement	NB	SB	Westbound			Eastbound		
			7 LT	8 R	9 R	10 LT	11 R	12 R
Lane Config	L	L	LT	R	R	LT	R	R
v (vph)	10	7	16		14	6		6
C(m) (vph)	356	698	125		549	78		363
v/c	0.03	0.01	0.13		0.03	0.08		0.02
95% queue length	0.09	0.03	0.43		0.08	0.24		0.05
Control Delay	15.4	10.2	38.0		11.7	55.0		15.1
LOS	C	B	E		B	F		C
Approach Delay				25.7				35.0+
Approach LOS				D				E

TWO-WAY STOP CONTROL SUMMARY

Analyst: AG  
 Agency/Co.: American  
 Date Performed: 06/17/2013  
 Analysis Time Period: PM Peak  
 Intersection: Ohio Street & US 41  
 Jurisdiction: FDOT D7  
 Units: U. S. Customary  
 Analysis Year: 2040 Build  
 Project ID: US 41 PD&E Study  
 East/West Street: Ohio Street  
 North/South Street: US 41  
 Intersection Orientation: NS Study period (hrs): 0.25

Vehicle Volumes and Adjustments

Major Street:	Approach Movement	Northbound			Southbound		
		1 L	2 T	3 R	4 L	5 T	6 R
Volume		889	20		113	1421	
Peak-Hour Factor, PHF		0.95	0.95		0.95	0.95	
Hourly Flow Rate, HFR		935	21		118	1495	
Percent Heavy Vehicles		--	--		5	--	--
Median Type/Storage		Raised curb			/ 1		
RT Channelized?							
Lanes		2	0		1	2	
Configuration		T	TR		L	T	
Upstream Signal?		No				No	

Minor Street:	Approach Movement	Westbound			Eastbound		
		7 L	8 T	9 R	10 L	11 T	12 R
Volume		25		45			
Peak Hour Factor, PHF		0.95		0.95			
Hourly Flow Rate, HFR		26		47			
Percent Heavy Vehicles		0		0			
Percent Grade (%)			0			0	
Flared Approach: Exists?/Storage				No	/		/
Lanes		0		0			
Configuration			LR				

Delay, Queue Length, and Level of Service

Approach Movement	NB 1	SB 4	Westbound			Eastbound		
			7	8	9	10	11	12
Lane Config		L		LR				
v (vph)		118		73				
C(m) (vph)		697		303				
v/c		0.17		0.24				
95% queue length		0.61		0.92				
Control Delay		11.2		20.6				
LOS		B		C				
Approach Delay				20.6				
Approach LOS				C				



TWO-WAY STOP CONTROL SUMMARY

Analyst: AG  
 Agency/Co.: American  
 Date Performed: 06/17/2013  
 Analysis Time Period: PM Peak  
 Intersection: Florence St & US 41  
 Jurisdiction: FDOT D7  
 Units: U. S. Customary  
 Analysis Year: 2040 Build  
 Project ID: US 41 PD&E Study  
 East/West Street: Florence Street  
 North/South Street: US 41  
 Intersection Orientation: NS  
 Study period (hrs): 0.25

Vehicle Volumes and Adjustments

Major Street:	Approach Movement	Northbound			Southbound		
		1 L	2 T	3 R	4 L	5 T	6 R
Volume		13	822	2	7	1485	20
Peak-Hour Factor, PHF		0.95	0.95	0.95	0.95	0.95	0.95
Hourly Flow Rate, HFR		13	865	2	7	1563	21
Percent Heavy Vehicles		5	--	--	5	--	--
Median Type/Storage		Raised curb			/ 1		
RT Channelized?							
Lanes		1	2	0	1	2	0
Configuration		L	T	TR	L	T	TR
Upstream Signal?		No			No		

Minor Street:	Approach Movement	Westbound			Eastbound		
		7 L	8 T	9 R	10 L	11 T	12 R
Volume				20		34	
Peak Hour Factor, PHF				0.95		0.95	
Hourly Flow Rate, HFR				21		35	
Percent Heavy Vehicles				0		0	
Percent Grade (%)		0			0		
Flared Approach: Exists?/Storage					/		
Lanes				1		1	
Configuration				R		R	





















Delay, Queue Length, and Level of Service

Approach Movement	NB	SB	Westbound			Eastbound		
			7	8	9	10	11	12
Lane Config	L	L			R			R
v (vph)	13	7			21			35
C(m) (vph)	397	754			626			392
v/c	0.03	0.01			0.03			0.09
95% queue length	0.10	0.03			0.10			0.29
Control Delay	14.4	9.8			11.0			15.1
LOS	B	A			B			C
Approach Delay				11.0			15.1	
Approach LOS				B			C	

# HCM Signalized Intersection Capacity Analysis

35: US 41 & Symmes Rd

5/3/2016

													
Movement	EBL	EBT	EBR	WBL	WBT	WBR	NBL	NBT	NBR	SBL	SBT	SBR	
Lane Configurations													
Volume (vph)	0	2	0	215	0	244	3	1115	134	535	2063	5	
Ideal Flow (vphpl)	1900	1900	1900	1900	1900	1900	1900	1900	1900	1900	1900	1900	
Total Lost time (s)		7.2			7.2	7.2	6.2	6.2	7.2	7.0	6.2		
Lane Util. Factor		1.00			1.00	1.00	1.00	0.91	1.00	1.00	0.91		
Frt		1.00			1.00	0.85	1.00	1.00	0.85	1.00	1.00		
Flt Protected		1.00			0.95	1.00	0.95	1.00	1.00	0.95	1.00		
Satd. Flow (prot)		1900			1736	1553	1719	4940	1538	1719	4938		
Flt Permitted		1.00			0.12	1.00	0.95	1.00	1.00	0.95	1.00		
Satd. Flow (perm)		1900			211	1553	1719	4940	1538	1719	4938		
Peak-hour factor, PHF	0.95	0.95	0.95	0.95	0.95	0.95	0.95	0.95	0.95	0.95	0.95	0.95	
Adj. Flow (vph)	0	2	0	226	0	257	3	1174	141	563	2172	5	
RTOR Reduction (vph)	0	0	0	0	0	0	0	0	77	0	0	0	
Lane Group Flow (vph)	0	2	0	0	226	257	3	1174	64	563	2177	0	
Heavy Vehicles (%)	0%	0%	0%	4%	4%	4%	5%	5%	5%	5%	5%	5%	
Turn Type		NA		Perm	NA	Perm	Prot	NA	custom	Prot	NA		
Protected Phases		8			4		1	6	7	5	2		
Permitted Phases	8			4		4			6				
Actuated Green, G (s)		3.2			34.6	34.6	0.8	30.8	55.0	35.0	65.8		
Effective Green, g (s)		3.2			34.6	34.6	0.8	30.8	55.0	35.0	65.8		
Actuated g/C Ratio		0.03			0.29	0.29	0.01	0.25	0.46	0.29	0.54		
Clearance Time (s)		7.2			7.2	7.2	6.2	6.2	7.2	7.0	6.2		
Vehicle Extension (s)		3.0			3.0	3.0	3.0	4.0	3.0	3.0	4.0		
Lane Grp Cap (vph)		50			60	444	11	1259	700	498	2689		
v/s Ratio Prot		0.00					0.00	c0.24	0.02	c0.33	0.44		
v/s Ratio Perm					c1.07	0.17			0.02				
v/c Ratio		0.04			3.77	0.58	0.27	0.93	0.09	1.13	0.81		
Uniform Delay, d1		57.3			43.1	36.9	59.7	44.0	18.7	42.9	22.4		
Progression Factor		1.00			1.00	1.00	1.00	1.00	1.00	1.00	1.00		
Incremental Delay, d2		0.3			1284.6	1.8	13.0	12.6	0.1	81.3	2.0		
Delay (s)		57.6			1327.7	38.7	72.7	56.6	18.8	124.2	24.4		
Level of Service		E			F	D	E	E	B	F	C		
Approach Delay (s)		57.6			641.8			52.6			44.9		
Approach LOS		E			F			D			D		
<b>Intersection Summary</b>													
HCM 2000 Control Delay			110.6		HCM 2000 Level of Service					F			
HCM 2000 Volume to Capacity ratio			2.12										
Actuated Cycle Length (s)			120.8		Sum of lost time (s)				27.6				
Intersection Capacity Utilization			86.8%		ICU Level of Service				E				
Analysis Period (min)			15										
c Critical Lane Group													

HCM Signalized Intersection Capacity Analysis  
46: US 41 & Palm Ave.

5/3/2016

Movement	EBL	EBT	EBR	WBL	WBT	WBR	NBL	NBT	NBR	SBL	SBT	SBR
Lane Configurations												
Volume (vph)	38	4	6	22	1	30	7	1426	15	66	2496	26
Ideal Flow (vphpl)	1900	1900	1900	1900	1900	1900	1900	1900	1900	1900	1900	1900
Total Lost time (s)		6.7		6.7	6.7		6.2	6.2		6.5	6.2	
Lane Util. Factor		1.00		1.00	1.00		1.00	0.91		1.00	0.91	
Frt		0.98		1.00	0.85		1.00	1.00		1.00	1.00	
Flt Protected		0.96		0.95	1.00		0.95	1.00		0.95	1.00	
Satd. Flow (prot)		1728		1805	1624		1719	4932		1719	4932	
Flt Permitted		0.75		0.72	1.00		0.95	1.00		0.95	1.00	
Satd. Flow (perm)		1342		1376	1624		1719	4932		1719	4932	
Peak-hour factor, PHF	0.95	0.95	0.95	0.95	0.95	0.95	0.95	0.95	0.95	0.95	0.95	0.95
Adj. Flow (vph)	40	4	6	23	1	32	7	1501	16	69	2627	27
RTOR Reduction (vph)	0	0	0	0	0	0	0	0	0	0	0	0
Lane Group Flow (vph)	0	50	0	23	33	0	7	1517	0	69	2654	0
Heavy Vehicles (%)	4%	4%	4%	0%	0%	0%	5%	5%	5%	5%	5%	5%
Turn Type	Perm	NA		Perm	NA		Prot	NA		Prot	NA	
Protected Phases		8			4		1	6		5	2	
Permitted Phases	8			4								
Actuated Green, G (s)		8.8		8.8	8.8		5.3	49.3		6.6	50.9	
Effective Green, g (s)		8.8		8.8	8.8		5.3	49.3		6.6	50.9	
Actuated g/C Ratio		0.10		0.10	0.10		0.06	0.59		0.08	0.61	
Clearance Time (s)		6.7		6.7	6.7		6.2	6.2		6.5	6.2	
Vehicle Extension (s)		3.0		3.0	3.0		4.0	4.0		2.5	4.0	
Lane Grp Cap (vph)		140		143	169		108	2891		134	2985	
v/s Ratio Prot					0.02		0.00	0.31		c0.04	c0.54	
v/s Ratio Perm		c0.04		0.02								
v/c Ratio		0.36		0.16	0.20		0.06	0.52		0.51	0.89	
Uniform Delay, d1		35.0		34.3	34.4		37.1	10.4		37.2	14.2	
Progression Factor		1.00		1.00	1.00		1.00	1.00		1.00	1.00	
Incremental Delay, d2		1.6		0.5	0.6		0.3	0.2		2.5	3.7	
Delay (s)		36.6		34.8	35.0		37.4	10.6		39.7	17.9	
Level of Service		D		C	C		D	B		D	B	
Approach Delay (s)		36.6			34.9			10.7			18.5	
Approach LOS		D			C			B			B	

Intersection Summary

HCM 2000 Control Delay	16.2	HCM 2000 Level of Service	B
HCM 2000 Volume to Capacity ratio	0.80		
Actuated Cycle Length (s)	84.1	Sum of lost time (s)	19.4
Intersection Capacity Utilization	74.9%	ICU Level of Service	D
Analysis Period (min)	15		

c Critical Lane Group

TWO-WAY STOP CONTROL SUMMARY

Analyst: AG  
 Agency/Co.: American  
 Date Performed: 06/17/2013  
 Analysis Time Period: PM Peak  
 Intersection: Nundy Ave & US 41  
 Jurisdiction: FDOT D7  
 Units: U. S. Customary  
 Analysis Year: 2040 Build  
 Project ID: US 41 PD&E Study  
 East/West Street: Nundy Ave  
 North/South Street: US 41  
 Intersection Orientation: NS

Study period (hrs): 0.25

Vehicle Volumes and Adjustments

Major Street:	Approach Movement	Northbound			Southbound		
		1 L	2 T	3 R	4 L	5 T	6 R
Volume		16	897	78	72	1689	11
Peak-Hour Factor, PHF		0.95	0.95	0.95	0.95	0.95	0.95
Hourly Flow Rate, HFR		16	944	82	75	1777	11
Percent Heavy Vehicles		5	--	--	5	--	--
Median Type/Storage		Raised curb			/ 1		
RT Channelized?							
Lanes		1	2	0	1	2	0
Configuration		L	T	TR	L	T	TR
Upstream Signal?		No			Yes		

Minor Street:	Approach Movement	Westbound			Eastbound		
		7 L	8 T	9 R	10 L	11 T	12 R
Volume				150			28
Peak Hour Factor, PHF				0.95			0.95
Hourly Flow Rate, HFR				157			29
Percent Heavy Vehicles				3			0
Percent Grade (%)		0			0		
Flared Approach: Exists?/Storage					/		
Lanes				1			1
Configuration				R			R

Delay, Queue Length, and Level of Service

Approach Movement	NB	SB	Westbound			Eastbound		
			7	8	9	10	11	12
Lane Config	L	L			R			R
v (vph)	16	75			157			29
C(m) (vph)	466	655			556			318
v/c	0.03	0.11			0.28			0.09
95% queue length	0.11	0.39			1.15			0.30
Control Delay	13.0	11.2			14.0			17.5
LOS	B	B			B			C
Approach Delay				14.0			17.5	
Approach LOS				B			C	

HCM Signalized Intersection Capacity Analysis  
 40: US 41 & Alice Ave/Gibsonton Dr

5/3/2016























Movement	EBL	EBT	EBR	WBL	WBT	WBR	NBL	NBT	NBR	SBL	SBT	SBR
Lane Configurations												
Volume (vph)	12	27	19	573	77	239	16	996	442	722	2356	25
Ideal Flow (vphpl)	1900	1900	1900	1900	1900	1900	1900	1900	1900	1900	1900	1900
Total Lost time (s)		9.0		9.0	9.0	9.0	6.1	6.1	6.1	6.7	6.1	
Lane Util. Factor		1.00		1.00	1.00	1.00	1.00	0.91	1.00	0.97	0.91	
Frt		0.96		1.00	1.00	0.85	1.00	1.00	0.85	1.00	1.00	
Flt Protected		0.99		0.95	1.00	1.00	0.95	1.00	1.00	0.95	1.00	
Satd. Flow (prot)		1695		1719	1810	1538	1719	4940	1538	3335	4932	
Flt Permitted		0.90		0.95	1.00	1.00	0.95	1.00	1.00	0.95	1.00	
Satd. Flow (perm)		1548		1719	1810	1538	1719	4940	1538	3335	4932	
Peak-hour factor, PHF	0.95	0.95	0.95	0.95	0.95	0.95	0.95	0.95	0.95	0.95	0.95	0.95
Adj. Flow (vph)	13	28	20	603	81	252	17	1048	465	760	2480	26
RTOR Reduction (vph)	0	0	0	0	0	0	0	0	0	0	0	0
Lane Group Flow (vph)	0	61	0	603	81	252	17	1048	465	760	2506	0
Heavy Vehicles (%)	6%	6%	6%	5%	5%	5%	5%	5%	5%	5%	5%	5%
Turn Type	Perm	NA		Prot	NA	pt+ov	Prot	NA	pt+ov	Prot	NA	
Protected Phases		8		7	4	4 5	1	6	6 7	5	2	
Permitted Phases	8											
Actuated Green, G (s)		16.0		28.0	53.0	105.3	2.4	34.3	68.4	43.3	75.8	
Effective Green, g (s)		16.0		28.0	53.0	105.3	2.4	34.3	68.4	43.3	75.8	
Actuated g/C Ratio		0.10		0.18	0.35	0.69	0.02	0.23	0.45	0.28	0.50	
Clearance Time (s)		9.0		9.0	9.0		6.1	6.1		6.7	6.1	
Vehicle Extension (s)		3.0		3.0	6.0		3.0	8.0		3.0	8.0	
Lane Grp Cap (vph)		162		315	629	1062	27	1111	690	947	2453	
v/s Ratio Prot				c0.35	0.04	0.16	0.01	0.21	0.30	c0.23	c0.51	
v/s Ratio Perm		c0.04										
v/c Ratio		0.38		1.91	0.13	0.24	0.63	0.94	0.67	0.80	1.02	
Uniform Delay, d1		63.6		62.2	33.9	8.7	74.6	58.1	33.2	50.6	38.3	
Progression Factor		1.00		1.00	1.00	1.00	1.00	1.00	1.00	1.00	1.00	
Incremental Delay, d2		6.6		423.1	0.4	0.5	38.0	16.4	2.6	7.1	23.9	
Delay (s)		70.1		485.3	34.4	9.2	112.6	74.5	35.8	57.7	62.2	
Level of Service		E		F	C	A	F	E	D	E	E	
Approach Delay (s)		70.1			318.1			63.2			61.1	
Approach LOS		E			F			E			E	

Intersection Summary			
HCM 2000 Control Delay	103.3	HCM 2000 Level of Service	F
HCM 2000 Volume to Capacity ratio	1.17		
Actuated Cycle Length (s)	152.4	Sum of lost time (s)	30.8
Intersection Capacity Utilization	105.5%	ICU Level of Service	G
Analysis Period (min)	15		

c Critical Lane Group

HCM Signalized Intersection Capacity Analysis  
 9: US 41 & Industrial Access Rd/Riverview Dr

5/3/2016

													
Movement	EBL	EBT	EBR	WBL	WBT	WBR	NBL	NBT	NBR	SBL	SBT	SBR	
Lane Configurations													
Volume (vph)	33	55	68	702	14	68	25	1213	488	164	2549	17	
Ideal Flow (vphpl)	1900	1900	1900	1900	1900	1900	1900	1900	1900	1900	1900	1900	
Total Lost time (s)		6.3	6.4		6.3	6.3	6.4	6.4	6.4	6.4	6.4	6.4	
Lane Util. Factor		1.00	1.00		1.00	1.00	1.00	0.91	1.00	1.00	0.91	1.00	
Frt		1.00	0.85		1.00	0.85	1.00	1.00	0.85	1.00	1.00	0.85	
Flt Protected		0.98	1.00		0.95	1.00	0.95	1.00	1.00	0.95	1.00	1.00	
Satd. Flow (prot)		1846	1599		1776	1583	1719	4940	1538	1719	4940	1538	
Flt Permitted		0.20	1.00		0.66	1.00	0.95	1.00	1.00	0.95	1.00	1.00	
Satd. Flow (perm)		368	1599		1235	1583	1719	4940	1538	1719	4940	1538	
Peak-hour factor, PHF	0.95	0.95	0.95	0.95	0.95	0.95	0.95	0.95	0.95	0.95	0.95	0.95	
Adj. Flow (vph)	35	58	72	739	15	72	26	1277	514	173	2683	18	
RTOR Reduction (vph)	0	0	48	0	0	0	0	0	277	0	0	0	
Lane Group Flow (vph)	0	93	24	0	754	72	26	1277	237	173	2683	18	
Heavy Vehicles (%)	1%	1%	1%	2%	2%	2%	5%	5%	5%	5%	5%	5%	
Turn Type	Perm	NA	pm+ov	Perm	NA	Prot	Prot	NA	Perm	Prot	NA	Prot	
Protected Phases		8	1		4	4	1	6		5	2	2	
Permitted Phases	8		8	4				6					
Actuated Green, G (s)		44.8	48.8		44.8	44.8	4.0	69.1	69.1	17.0	82.1	82.1	
Effective Green, g (s)		44.8	48.8		44.8	44.8	4.0	69.1	69.1	17.0	82.1	82.1	
Actuated g/C Ratio		0.30	0.33		0.30	0.30	0.03	0.46	0.46	0.11	0.55	0.55	
Clearance Time (s)		6.3	6.4		6.3	6.3	6.4	6.4	6.4	6.4	6.4	6.4	
Vehicle Extension (s)		6.0	3.0		6.0	6.0	3.0	8.0	8.0	3.0	8.0	8.0	
Lane Grp Cap (vph)		109	520		368	472	45	2275	708	194	2703	841	
v/s Ratio Prot			0.00			0.05	0.02	0.26		c0.10	c0.54	0.01	
v/s Ratio Perm		0.25	0.01		c0.61				0.15				
v/c Ratio		0.85	0.05		2.05	0.15	0.58	0.56	0.33	0.89	0.99	0.02	
Uniform Delay, d1		49.5	34.7		52.6	38.7	72.2	29.4	25.8	65.6	33.6	15.6	
Progression Factor		1.00	1.00		1.00	1.00	1.00	1.00	1.00	1.00	1.00	1.00	
Incremental Delay, d2		48.6	0.0		481.4	0.4	16.7	1.0	1.3	36.2	15.7	0.0	
Delay (s)		98.2	34.7		534.0	39.1	88.9	30.4	27.1	101.7	49.3	15.6	
Level of Service		F	C		F	D	F	C	C	F	D	B	
Approach Delay (s)		70.5			490.8			30.3			52.3		
Approach LOS		E			F			C			D		

Intersection Summary

HCM 2000 Control Delay	109.5	HCM 2000 Level of Service	F
HCM 2000 Volume to Capacity ratio	1.38		
Actuated Cycle Length (s)	150.0	Sum of lost time (s)	19.1
Intersection Capacity Utilization	114.8%	ICU Level of Service	H
Analysis Period (min)	15		

c Critical Lane Group

HCM Signalized Intersection Capacity Analysis  
 10: US 41 & Pendola Point Rd/CR 676A (Madison Ave)

5/3/2016

Movement	EBL	EBT	EBR	WBL	WBT	WBR	NBL	NBT	NBR	SBL	SBT	SBR
Lane Configurations												
Volume (vph)	134	64	14	191	0	350	3	1441	75	647	2678	8
Ideal Flow (vphpl)	1900	1900	1900	1900	1900	1900	1900	1900	1900	1900	1900	1900
Total Lost time (s)	8.1	8.1			7.1	7.1	7.5	7.5	7.5	7.5	7.5	7.5
Lane Util. Factor	1.00	1.00			1.00	0.88	1.00	0.91	1.00	0.97	0.91	1.00
Fr't	1.00	0.97			1.00	0.85	1.00	1.00	0.85	1.00	1.00	0.85
Flt Protected	0.95	1.00			0.95	1.00	0.95	1.00	1.00	0.95	1.00	1.00
Satd. Flow (prot)	1583	1621			1656	2608	1719	4940	1538	3335	4940	1538
Flt Permitted	0.47	1.00			0.70	1.00	0.95	1.00	1.00	0.95	1.00	1.00
Satd. Flow (perm)	775	1621			1227	2608	1719	4940	1538	3335	4940	1538
Peak-hour factor, PHF	0.95	0.95	0.95	0.95	0.95	0.95	0.95	0.95	0.95	0.95	0.95	0.95
Adj. Flow (vph)	141	67	15	201	0	368	3	1517	79	681	2819	8
RTOR Reduction (vph)	0	8	0	0	0	0	0	0	47	0	0	3
Lane Group Flow (vph)	141	74	0	0	201	368	3	1517	32	681	2819	5
Heavy Vehicles (%)	14%	14%	14%	9%	9%	9%	5%	5%	5%	5%	5%	5%
Turn Type	Perm	NA		Perm	NA	pt+ov	Prot	NA	Perm	Prot	NA	Perm
Protected Phases		8			4	4.5	1	6		5	2	
Permitted Phases	8			4				6				2
Actuated Green, G (s)	18.9	18.9			19.9	53.4	0.8	47.6	47.6	26.4	73.2	73.2
Effective Green, g (s)	18.9	18.9			19.9	53.4	0.8	47.6	47.6	26.4	73.2	73.2
Actuated g/C Ratio	0.16	0.16			0.17	0.46	0.01	0.41	0.41	0.23	0.63	0.63
Clearance Time (s)	8.1	8.1			7.1		7.5	7.5	7.5	7.5	7.5	7.5
Vehicle Extension (s)	6.0	6.0			6.0		6.0	8.0	8.0	6.0	8.0	8.0
Lane Grp Cap (vph)	126	264			210	1200	11	2027	631	759	3117	970
v/s Ratio Prot		0.05				0.14	0.00	0.31		c0.20	c0.57	
v/s Ratio Perm	c0.18				0.16				0.02			0.00
v/c Ratio	1.12	0.28			0.96	0.31	0.27	0.75	0.05	0.90	0.90	0.01
Uniform Delay, d1	48.5	42.6			47.6	19.7	57.3	29.1	20.6	43.5	18.4	7.9
Progression Factor	1.00	1.00			1.00	1.00	1.00	1.00	1.00	1.00	1.00	1.00
Incremental Delay, d2	115.7	1.7			51.0	0.4	34.4	2.6	0.2	14.6	4.9	0.0
Delay (s)	164.3	44.2			98.6	20.1	91.7	31.7	20.8	58.1	23.3	7.9
Level of Service	F	D			F	C	F	C	C	E	C	A
Approach Delay (s)		120.1			47.8			31.3			30.0	
Approach LOS		F			D			C			C	

Intersection Summary

HCM 2000 Control Delay	35.5	HCM 2000 Level of Service	D
HCM 2000 Volume to Capacity ratio	1.00		
Actuated Cycle Length (s)	116.0	Sum of lost time (s)	23.1
Intersection Capacity Utilization	90.7%	ICU Level of Service	E
Analysis Period (min)	15		

c Critical Lane Group

HCM Signalized Intersection Capacity Analysis  
 17: US 41 & Port Sutton Rd

5/3/2016



Movement	EBL	EBR	NBL	NBT	SBU	SBT	SBR
Lane Configurations	↘	↗	↘	↑↑↑	↘	↑↑↑	↗
Volume (vph)	139	98	0	1853	2	3519	7
Ideal Flow (vphpl)	1900	1900	1900	1900	1900	1900	1900
Total Lost time (s)	7.7	7.0		6.7	6.4	6.7	7.7
Lane Util. Factor	1.00	1.00		0.91	1.00	0.91	1.00
Frt	1.00	0.85		1.00	1.00	1.00	0.85
Flt Protected	0.95	1.00		1.00	0.95	1.00	1.00
Satd. Flow (prot)	1805	1615		4940	1719	4940	1538
Flt Permitted	0.95	1.00		1.00	0.95	1.00	1.00
Satd. Flow (perm)	1805	1615		4940	1719	4940	1538
Peak-hour factor, PHF	0.95	0.95	0.95	0.95	0.95	0.95	0.95
Adj. Flow (vph)	146	103	0	1951	2	3704	7
RTOR Reduction (vph)	0	1	0	0	0	0	1
Lane Group Flow (vph)	146	102	0	1951	2	3704	6
Heavy Vehicles (%)	0%	0%	5%	5%	5%	5%	5%
Turn Type	Prot	pm+ov	Prot	NA	Prot	NA	pm+ov
Protected Phases	8	1	1	6	5	2	8
Permitted Phases		8					2
Actuated Green, G (s)	15.7	20.7		117.3	1.0	112.7	128.4
Effective Green, g (s)	15.7	20.7		117.3	1.0	112.7	128.4
Actuated g/C Ratio	0.10	0.13		0.76	0.01	0.73	0.83
Clearance Time (s)	7.7	7.0		6.7	6.4	6.7	7.7
Vehicle Extension (s)	6.0	3.0		8.0	3.0	8.0	6.0
Lane Grp Cap (vph)	183	215		3743	11	3596	1275
v/s Ratio Prot	c0.08	c0.02		c0.39	0.00	c0.75	0.00
v/s Ratio Perm		0.05					0.00
v/c Ratio	0.80	0.48		0.52	0.18	1.03	0.00
Uniform Delay, d1	68.0	62.0		7.5	76.5	21.1	2.3
Progression Factor	1.00	1.00		1.00	1.00	1.00	1.00
Incremental Delay, d2	24.9	1.7		0.5	7.8	23.4	0.0
Delay (s)	92.9	63.7		8.0	84.3	44.5	2.3
Level of Service	F	E		A	F	D	A
Approach Delay (s)	80.8			8.0		44.4	
Approach LOS	F			A		D	

Intersection Summary			
HCM 2000 Control Delay	33.9	HCM 2000 Level of Service	C
HCM 2000 Volume to Capacity ratio	0.99		
Actuated Cycle Length (s)	154.8	Sum of lost time (s)	21.4
Intersection Capacity Utilization	87.7%	ICU Level of Service	E
Analysis Period (min)	15		

c Critical Lane Group



TWO-WAY STOP CONTROL SUMMARY

Analyst: AG  
 Agency/Co.: American  
 Date Performed: 06/17/2013  
 Analysis Time Period: PM Peak  
 Intersection: Hartford St & US 41  
 Jurisdiction: FDOT D7  
 Units: U. S. Customary  
 Analysis Year: 2040 Build  
 Project ID: US 41 PD&E Study  
 East/West Street: Hartford Street  
 North/South Street: US 41  
 Intersection Orientation: NS  
 Study period (hrs): 0.25

Vehicle Volumes and Adjustments

Major Street:	Approach Movement	Northbound			Southbound		
		1 L	2 T	3 R	4 L	5 T	6 R
Volume		12	1274	37	70	2595	4
Peak-Hour Factor, PHF		0.95	0.95	0.95	0.95	0.95	0.95
Hourly Flow Rate, HFR		12	1341	38	73	2731	4
Percent Heavy Vehicles		5	--	--	5	--	--
Median Type/Storage		Raised curb			/ 1		
RT Channelized?							
Lanes		1	2	0	1	2	0
Configuration		L	T	TR	L	T	TR
Upstream Signal?		No			No		

Minor Street:	Approach Movement	Westbound			Eastbound		
		7 L	8 T	9 R	10 L	11 T	12 R
Volume		35	0	102	17	0	10
Peak Hour Factor, PHF		0.95	0.95	0.95	0.95	0.95	0.95
Hourly Flow Rate, HFR		36	0	107	17	0	10
Percent Heavy Vehicles		13	13	13	10	10	10
Percent Grade (%)		0			0		
Flared Approach: Exists?/Storage		No			/ No /		
Lanes		0	1	0	0	1	0
Configuration		LTR			LTR		

Delay, Queue Length, and Level of Service

Approach Movement	NB	SB	Westbound			Eastbound		
			7	8	9	10	11	12
Lane Config	L	L	LTR	LTR	LTR	LTR	LTR	LTR
v (vph)	12	73	143			27		
C(m) (vph)	137	478	137			15		
v/c	0.09	0.15	1.04			1.80		
95% queue length	0.28	0.54	7.71			4.02		
Control Delay	33.8	13.9	152.7			901.2		
LOS	D	B	F			F		
Approach Delay			152.7			901.2		
Approach LOS			F			F		

## Arterial Level of Service: NB US 41

Cross Street	Arterial Class	Flow Speed	Running Time	Signal Delay	Travel Time (s)	Dist (mi)	Arterial Speed	Arterial LOS
Symmes Rd	II	45	162.3	72.1	234.4	2.03	31.2	B
Palm Ave.	II	40	40.6	11.7	52.3	0.42	29.1	B
Gibsonton Dr	II	40	52.7	85.7	138.4	0.59	15.2	E
Riverview Dr	II	40	93.1	30.7	123.8	1.03	30.1	B
CR 676A (Madison Ave	II	45	222.0	35.0	257.0	2.77	38.9	A
Port Sutton Rd	II	45	34.3	6.7	41.0	0.36	31.4	B
Total	II		605.0	241.9	846.9	7.20	30.6	B

## Arterial Level of Service: SB US 41

Cross Street	Arterial Class	Flow Speed	Running Time	Signal Delay	Travel Time (s)	Dist (mi)	Arterial Speed	Arterial LOS
Port Sutton Rd	II	45	92.6	49.7	142.3	1.16	29.3	B
Pendola Point Rd	II	45	34.3	18.7	53.0	0.36	24.3	C
Industrial Access Rd	II	45	222.0	49.1	271.1	2.77	36.8	A
Alice Ave	II	40	93.1	56.0	149.1	1.03	25.0	C
Palm Ave.	II	40	52.7	20.3	73.0	0.59	28.9	B
Symmes Rd	II	40	40.6	18.5	59.1	0.42	25.7	C
Total	II		535.3	212.3	747.6	6.33	30.5	B

# Appendix G

## Interim Year 2030 No-Build and Build Level of Service

TWO-WAY STOP CONTROL SUMMARY

Analyst: AG  
 Agency/Co.: American  
 Date Performed: 06/17/2013  
 Analysis Time Period: AM Peak  
 Intersection: Kracker Avenue & US 41  
 Jurisdiction: FDOT D7  
 Units: U. S. Customary  
 Analysis Year: 2030 No Build  
 Project ID: US 41 PD&E Study  
 East/West Street: Kracker Ave  
 North/South Street: US 41  
 Intersection Orientation: NS Study period (hrs): 0.25

Vehicle Volumes and Adjustments

Major Street: Approach Movement	Northbound			Southbound		
	1 L	2 T	3 R	4 L	5 T	6 R
Volume	7	2009	9	2	1125	3
Peak-Hour Factor, PHF	0.95	0.95	0.95	0.95	0.95	0.95
Hourly Flow Rate, HFR	7	2114	9	2	1184	3
Percent Heavy Vehicles	5	--	--	5	--	--
Median Type/Storage	Raised curb			/ 1		
RT Channelized?	No			Yes		
Lanes Configuration	1 L	2 T	1 R	1 L	2 T	1 R
Upstream Signal?	No			No		

Minor Street: Approach Movement	Westbound			Eastbound		
	7 L	8 T	9 R	10 L	11 T	12 R
Volume	20	0	8	7	0	11
Peak Hour Factor, PHF	0.95	0.95	0.95	0.95	0.95	0.95
Hourly Flow Rate, HFR	21	0	8	7	0	11
Percent Heavy Vehicles	0	0	0	0	0	0
Percent Grade (%)	0			0		
Flared Approach: Exists?/Storage	/			/		
Lanes Configuration	0 LT	1 R	1 R	0 LT	1 R	1 R

Delay, Queue Length, and Level of Service

Approach Movement Lane Config	NB	SB	Westbound		Eastbound		
	1 L	4 L	7 LT	8 R	9 R	10 LT	11 R
v (vph)	7	2	21	8	7	11	11
C(m) (vph)	569	243	43	276	107	510	510
v/c	0.01	0.01	0.49	0.03	0.07	0.02	0.02
95% queue length	0.04	0.02	1.75	0.09	0.21	0.07	0.07
Control Delay	11.4	19.9	151.5	18.4	41.0	12.2	12.2
LOS	B	C	F	C	E	B	B
Approach Delay	114.8			23.4			
Approach LOS	F			C			

## TWO-WAY STOP CONTROL SUMMARY

Analyst: AG  
 Agency/Co.: American  
 Date Performed: 06/17/2013  
 Analysis Time Period: AM Peak  
 Intersection: Ohio Street & US 41  
 Jurisdiction: FDOT D7  
 Units: U. S. Customary  
 Analysis Year: 2030 No Build  
 Project ID: US 41 PD&E Study  
 East/West Street: Ohio St  
 North/South Street: US 41  
 Intersection Orientation: NS

Study period (hrs): 0.25

		Vehicle Volumes and Adjustments					
Major Street:	Approach Movement	Northbound			Southbound		
		1 L	2 T	3 R	4 L	5 T	6 R
Volume		2014	19		69	1021	
Peak-Hour Factor, PHF		0.95	0.95		0.95	0.95	
Hourly Flow Rate, HFR		2120	20		72	1074	
Percent Heavy Vehicles		--	--		5	--	--
Median Type/Storage		Raised curb			/ 1		
RT Channelized?							
Lanes		2	0		1	2	
Configuration		T	TR		L	T	
Upstream Signal?		No			No		

		Westbound			Eastbound		
Minor Street:	Approach Movement	7	8	9	10	11	12
		L	T	R	L	T	R
Volume		36		36			
Peak Hour Factor, PHF		0.95		0.95			
Hourly Flow Rate, HFR		37		37			
Percent Heavy Vehicles		16		16			
Percent Grade (%)			0			0	
Flared Approach: Exists?/Storage				No	/		/
Lanes		0		0			
Configuration			LR				

		Delay, Queue Length, and Level of Service						
Approach	NB	SB	Westbound			Eastbound		
			7	8	9	10	11	12
Movement	1	4						
Lane Config		L		LR				
v (vph)		72		74				
C(m) (vph)		239		83				
v/c		0.30		0.89				
95% queue length		1.22		4.74				
Control Delay		26.4		158.1				
LOS		D		F				
Approach Delay				158.1				
Approach LOS				F				

## TWO-WAY STOP CONTROL SUMMARY

Analyst: AG  
 Agency/Co.: American  
 Date Performed: 06/17/2013  
 Analysis Time Period: AM Peak  
 Intersection: Florence St & US 41  
 Jurisdiction: FDOT D7  
 Units: U. S. Customary  
 Analysis Year: 2030 No Build  
 Project ID: US 41 PD&E Study  
 East/West Street: Florence St  
 North/South Street: US 41  
 Intersection Orientation: NS

Study period (hrs): 0.25

Major Street:	Approach Movement	Vehicle Volumes and Adjustments					
		Northbound			Southbound		
		1	2	3	4	5	6
		L	T	R	L	T	R
Volume		7	1954	0	3	1063	19
Peak-Hour Factor, PHF		0.95	0.95	0.95	0.95	0.95	0.95
Hourly Flow Rate, HFR		7	2056	0	3	1118	20
Percent Heavy Vehicles		5	--	--	5	--	--
Median Type/Storage		Raised curb			/ 1		
RT Channelized?							
Lanes		1	2	0	1	2	0
Configuration		L	T	TR	L	T	TR
Upstream Signal?		No			No		

Minor Street:	Approach Movement	Vehicle Volumes and Adjustments					
		Westbound			Eastbound		
		7	8	9	10	11	12
		L	T	R	L	T	R
Volume		7	0	15	15	0	9
Peak Hour Factor, PHF		0.95	0.95	0.95	0.95	0.95	0.95
Hourly Flow Rate, HFR		7	0	15	15	0	9
Percent Heavy Vehicles		0	0	0	0	0	0
Percent Grade (%)		0			0		
Flared Approach: Exists?/Storage		No			/ No /		
Lanes		0	1	0	0	1	0
Configuration		LTR			LTR		

Approach	Delay, Queue Length, and Level of Service								
	NB	SB	Westbound			Eastbound			
Movement	1	4	7	8	9	10	11	12	
Lane Config	L	L		LTR			LTR		
v (vph)	7	3	22			24			
C(m) (vph)	593	258	111			160			
v/c	0.01	0.01	0.20			0.15			
95% queue length	0.04	0.04	0.70			0.51			
Control Delay	11.1	19.1	45.3			31.4			
LOS	B	C	E			D			
Approach Delay				45.3			31.4		
Approach LOS				E			D		

HCM Signalized Intersection Capacity Analysis  
 35: Symmes Rd & US 41

7/23/2013



Movement	EBL	EBT	EBR	WBL	WBT	WBR	NBL	NBT	NBR	SBL	SBT	SBR
Lane Configurations		↔		↙	↘			↙	↘	↙	↘	↔
Volume (vph)	1	0	0	240	0	563	15	1748	189	180	1053	0
Ideal Flow (vphpl)	1900	1900	1900	1900	1900	1900	1900	1900	1900	1900	1900	1900
Total Lost time (s)		7.2		7.2	7.2			6.2	6.2	7.0	6.2	
Lane Util. Factor		1.00		1.00	1.00			0.95	1.00	1.00	0.95	
Frt		1.00		1.00	0.85			1.00	0.85	1.00	1.00	
Flt Protected		0.95		0.95	1.00			1.00	1.00	0.95	1.00	
Satd. Flow (prot)		1805		1703	1524			3437	1538	1719	3438	
Flt Permitted		0.10		0.76	1.00			0.94	1.00	0.04	1.00	
Satd. Flow (perm)		191		1357	1524			3216	1538	80	3438	
Peak-hour factor, PHF	0.95	0.95	0.95	0.95	0.95	0.95	0.95	0.95	0.95	0.95	0.95	0.95
Adj. Flow (vph)	1	0	0	253	0	593	16	1840	199	189	1108	0
RTOR Reduction (vph)	0	0	0	0	0	0	0	0	55	0	0	0
Lane Group Flow (vph)	0	1	0	253	593	0	0	1856	144	189	1108	0
Heavy Vehicles (%)	0%	0%	0%	6%	6%	6%	5%	5%	5%	5%	5%	5%
Turn Type	Perm			Perm			Perm		Perm	pm+pt		
Protected Phases		8			4			6			5	2
Permitted Phases	8			4			6		6		2	
Actuated Green, G (s)		39.8		39.8	39.8			83.8	83.8	96.8	96.8	
Effective Green, g (s)		39.8		39.8	39.8			83.8	83.8	96.8	96.8	
Actuated g/C Ratio		0.27		0.27	0.27			0.56	0.56	0.65	0.65	
Clearance Time (s)		7.2		7.2	7.2			6.2	6.2	7.0	6.2	
Vehicle Extension (s)		3.0		3.0	3.0			4.0	4.0	3.0	4.0	
Lane Grp Cap (vph)		51		360	404			1797	859	117	2219	
v/s Ratio Prot					c0.39					c0.06	0.32	
v/s Ratio Perm		0.01		0.19				0.58	0.09	c0.98		
v/c Ratio		0.02		0.70	1.47			1.03	0.17	1.62	0.50	
Uniform Delay, d1		40.7		49.8	55.1			33.1	16.1	46.5	13.9	
Progression Factor		1.00		1.00	1.00			1.00	1.00	1.00	1.00	
Incremental Delay, d2		0.2		6.1	223.7			30.2	0.1	312.7	0.2	
Delay (s)		40.8		55.9	278.8			63.3	16.2	359.2	14.2	
Level of Service		D		E	F			E	B	F	B	
Approach Delay (s)		40.8			212.1			58.7			64.4	
Approach LOS		D			F			E			E	

Intersection Summary

HCM Average Control Delay	91.4	HCM Level of Service	F
HCM Volume to Capacity ratio	1.53		
Actuated Cycle Length (s)	150.0	Sum of lost time (s)	14.2
Intersection Capacity Utilization	129.1%	ICU Level of Service	H
Analysis Period (min)	15		

c Critical Lane Group

HCM Signalized Intersection Capacity Analysis  
46: Palm Ave. & US 41

7/23/2013

Movement	EBL	EBT	EBR	WBL	WBT	WBR	NBL	NBT	NBR	SBL	SBT	SEB
Lane Configurations		↔		↙	↘		↙	↕	↘	↙	↕	↘
Volume (vph)	40	0	19	3	0	24	4	2206	8	36	1210	6
Ideal Flow (vphpl)	1900	1900	1900	1900	1900	1900	1900	1900	1900	1900	1900	1900
Total Lost time (s)		6.7		6.7	6.7		6.2	6.2	6.2	6.5	6.5	
Lane Util. Factor		1.00		1.00	1.00		1.00	0.95	1.00	1.00	0.95	
Flt		0.96		1.00	0.85		1.00	1.00	0.85	1.00	1.00	
Flt Protected		0.97		0.95	1.00		0.95	1.00	1.00	0.95	1.00	
Satd. Flow (prot)		1758		1805	1615		1719	3438	1538	1719	3436	
Flt Permitted		0.78		0.80	1.00		0.22	1.00	1.00	0.05	1.00	
Satd. Flow (perm)		1420		1516	1615		392	3438	1538	88	3436	
Peak-hour factor, PHF	0.95	0.95	0.95	0.95	0.95	0.95	0.95	0.95	0.95	0.95	0.95	0.95
Adj. Flow (vph)	42	0	20	3	0	25	4	2322	8	38	1274	6
RTOR Reduction (vph)	0	0	0	0	0	0	0	0	2	0	0	0
Lane Group Flow (vph)	0	62	0	3	25	0	4	2322	6	38	1280	0
Heavy Vehicles (%)	0%	0%	0%	0%	0%	0%	5%	5%	5%	5%	5%	5%
Turn Type	Perm			Perm			Perm		Perm	pm+pt		
Protected Phases		4			4			2			1	1 2
Permitted Phases	4			4			2		2		1 2	
Actuated Green, G (s)		10.4		10.4	10.4		82.1	82.1	82.1	88.6	95.1	
Effective Green, g (s)		10.4		10.4	10.4		82.1	82.1	82.1	88.6	95.1	
Actuated g/C Ratio		0.09		0.09	0.09		0.69	0.69	0.69	0.75	0.80	
Clearance Time (s)		6.7		6.7	6.7		6.2	6.2	6.2	6.5	6.5	
Vehicle Extension (s)		3.0		3.0	3.0		4.0	4.0	4.0	2.5	2.5	
Lane Grp Cap (vph)		125		133	142		272	2384	1066	155	2760	
v/s Ratio Prot					0.02			c0.68		0.01	c0.37	
v/s Ratio Perm		c0.04		0.00			0.01		0.00	0.17		
v/c Ratio		0.50		0.02	0.18		0.01	0.97	0.01	0.25	0.46	
Uniform Delay, d1		51.5		49.4	50.0		5.6	17.1	5.6	26.2	3.7	
Progression Factor		1.00		1.00	1.00		1.00	1.00	1.00	1.00	1.00	
Incremental Delay, d2		3.1		0.1	0.6		0.0	12.9	0.0	0.6	0.1	
Delay (s)		54.6		49.4	50.6		5.7	30.0	5.6	26.8	3.7	
Level of Service		D		D	D		A	C	A	C	A	
Approach Delay (s)		54.6			50.5			29.9			4.4	
Approach LOS		D			D			C			A	

Intersection Summary

HCM Average Control Delay	21.5	HCM Level of Service	C
HCM Volume to Capacity ratio	0.91		
Actuated Cycle Length (s)	118.4	Sum of lost time (s)	19.4
Intersection Capacity Utilization	81.8%	ICU Level of Service	D
Analysis Period (min)	15		

c Critical Lane Group



## TWO-WAY STOP CONTROL SUMMARY

Analyst: AG  
 Agency/Co.: American  
 Date Performed: 06/17/2013  
 Analysis Time Period: AM Peak  
 Intersection: Nundy Ave & US 41  
 Jurisdiction: FDOT D7  
 Units: U. S. Customary  
 Analysis Year: 2030 No Build  
 Project ID: US 41 PD&E Study  
 East/West Street: Nundy Ave  
 North/South Street: US 41  
 Intersection Orientation: NS Study period (hrs): 0.25

## Vehicle Volumes and Adjustments

Major Street:	Approach Movement	Northbound			Southbound		
		1 L	2 T	3 R	4 L	5 T	6 R
Volume		14	2214	23	35	1209	4
Peak-Hour Factor, PHF		0.95	0.95	0.95	0.95	0.95	0.95
Hourly Flow Rate, HFR		14	2330	24	36	1272	4
Percent Heavy Vehicles		5	--	--	5	--	--
Median Type/Storage		Raised curb			/ 1		
RT Channelized?							
Lanes		1	2	0	1	2	0
Configuration		L	T	TR	L	T	TR
Upstream Signal?		No			Yes		

Minor Street:	Approach Movement	Westbound			Eastbound		
		7 L	8 T	9 R	10 L	11 T	12 R
Volume		63	0	95	2	5	11
Peak Hour Factor, PHF		0.95	0.95	0.95	0.95	0.95	0.95
Hourly Flow Rate, HFR		66	0	100	2	5	11
Percent Heavy Vehicles		10	10	10	0	0	0
Percent Grade (%)		0			0		
Flared Approach: Exists?/Storage		No			/ No /		
Lanes		0	1	0	0	1	0
Configuration		LTR			LTR		

## Delay, Queue Length, and Level of Service

Approach Movement	NB 1 L	SB 4 L	Westbound			Eastbound		
			7	8 LTR	9	10	11 LTR	12
v (vph)	14	36	166			18		
C(m) (vph)	676	196	57			71		
v/c	0.02	0.18	2.91			0.25		
95% queue length	0.06	0.65	17.24			0.90		
Control Delay	10.4	27.5	1016			72.1		
LOS	B	D	F			F		
Approach Delay			1016			72.1		
Approach LOS			F			F		

HCM Signalized Intersection Capacity Analysis  
40: Alice Ave & US 41

7/23/2013



Movement	EBL	EBT	EBR	WBL	WBT	WBR	NBL	NBT	NBR	SSL	SBT	SBR
Lane Configurations		↕		↖	↗	↗	↖	↕	↖	↖	↕	↖
Volume (vph)	18	33	8	393	78	607	14	1957	273	296	1108	21
Ideal Flow (vphpl)	1900	1900	1900	1900	1900	1900	1900	1900	1900	1900	1900	1900
Total Lost time (s)		9.0		9.0	9.0	6.7	6.1	6.1	6.1	6.7	6.1	
Lane Util. Factor		1.00		1.00	1.00	1.00	1.00	0.95	1.00	1.00	0.95	
Frt		0.98		1.00	1.00	0.85	1.00	1.00	0.85	1.00	1.00	
Flt Protected		0.98		0.95	1.00	1.00	0.95	1.00	1.00	0.95	1.00	
Satd. Flow (prot)		1839		1703	1792	1524	1719	3438	1538	1719	3429	
Flt Permitted		0.90		0.72	1.00	1.00	0.22	1.00	1.00	0.04	1.00	
Satd. Flow (perm)		1674		1284	1792	1524	390	3438	1538	64	3429	
Peak-hour factor, PHF	0.95	0.95	0.95	0.95	0.95	0.95	0.95	0.95	0.95	0.95	0.95	0.95
Adj. Flow (vph)	19	35	8	414	82	639	15	2060	287	312	1166	22
RTOR Reduction (vph)	0	0	0	0	0	0	0	0	39	0	0	0
Lane Group Flow (vph)	0	62	0	414	82	639	15	2060	248	312	1188	0
Heavy Vehicles (%)	0%	0%	0%	6%	6%	6%	5%	5%	5%	5%	5%	5%
Turn Type	Perm			Perm		pm+ov	Perm		Perm		pm+pt	
Protected Phases		8			4	5		6			5	2
Permitted Phases	8			4		4	6		6		2	
Actuated Green, G (s)		43.0		43.0	43.0	51.3	106.9	106.9	106.9	121.9	121.9	
Effective Green, g (s)		43.0		43.0	43.0	51.3	106.9	106.9	106.9	121.9	121.9	
Actuated g/C Ratio		0.24		0.24	0.24	0.28	0.59	0.59	0.59	0.68	0.68	
Clearance Time (s)		9.0		9.0	9.0	6.7	6.1	6.1	6.1	6.7	6.1	
Vehicle Extension (s)		3.0		6.0	6.0	3.0	8.0	8.0	8.0	3.0	8.0	
Lane Grp Cap (vph)		400		307	428	434	232	2042	913	120	2322	
v/s Ratio Prot					0.05	c0.07		0.60		c0.12	0.35	
v/s Ratio Perm		0.04		0.32		0.35	0.04		0.16	c1.65		
v/c Ratio		0.15		1.35	0.19	1.47	0.06	1.01	0.27	2.60	0.51	
Uniform Delay, d1		54.1		68.5	54.6	64.3	15.4	36.5	17.7	64.3	14.3	
Progression Factor		1.00		1.00	1.00	1.00	1.00	1.00	1.00	1.00	1.00	
Incremental Delay, d2		0.8		176.9	1.0	224.8	0.5	22.1	0.7	743.6	0.8	
Delay (s)		55.0		245.4	55.6	289.1	16.0	58.6	18.4	807.9	15.2	
Level of Service		D		F	E	F	B	E	B	F	B	
Approach Delay (s)		55.0			256.3			53.5			180.1	
Approach LOS		D			F			D			F	

Intersection Summary

HCM Average Control Delay	136.5	HCM Level of Service	F
HCM Volume to Capacity ratio	2.22		
Actuated Cycle Length (s)	180.0	Sum of lost time (s)	13.4
Intersection Capacity Utilization	117.1%	ICU Level of Service	H
Analysis Period (min)	15		

c Critical Lane Group

HCM Signalized Intersection Capacity Analysis  
 9: Industrial Access Rd & US 41

7/23/2013



Movement	EBL	EBT	EBR	WBL	WBT	WBR	NBL	NBT	NBR	SBL	SBT	SBR
Lane Configurations		↖	↗		↖	↗	↘	↕	↗	↘	↕	↗
Volume (vph)	9	14	20	433	48	295	81	2241	241	24	1208	41
Ideal Flow (vphpl)	1900	1900	1900	1900	1900	1900	1900	1900	1900	1900	1900	1900
Total Lost time (s)		6.3	6.3		6.3	6.3	6.4	6.4	6.4	6.4	6.4	6.4
Lane Util. Factor		1.00	1.00		1.00	1.00	1.00	0.95	1.00	1.00	0.95	1.00
Frt		1.00	0.85		1.00	0.85	1.00	1.00	0.85	1.00	1.00	0.85
Flt Protected		0.98	1.00		0.96	1.00	0.95	1.00	1.00	0.95	1.00	1.00
Satd. Flow (prot)		1636	1417		1715	1524	1719	3438	1538	1719	3438	1538
Flt Permitted		0.46	1.00		0.73	1.00	0.17	1.00	1.00	0.04	1.00	1.00
Satd. Flow (perm)		762	1417		1309	1524	305	3438	1538	72	3438	1538
Peak-hour factor, PHF	0.95	0.95	0.95	0.95	0.95	0.95	0.95	0.95	0.95	0.95	0.95	0.95
Adj. Flow (vph)	9	15	21	456	51	311	85	2359	254	25	1272	43
RTOR Reduction (vph)	0	0	16	0	0	7	0	0	53	0	0	14
Lane Group Flow (vph)	0	24	5	0	507	304	85	2359	201	25	1272	29
Heavy Vehicles (%)	14%	14%	14%	6%	6%	6%	5%	5%	5%	5%	5%	5%
Turn Type	Perm		Perm	Perm		Perm	Perm		Perm	Perm		Perm
Protected Phases		4			4			2				2
Permitted Phases	4		4	4		4	2		2	2		2
Actuated Green, G (s)		36.7	36.7		36.7	36.7	100.6	100.6	100.6	100.6	100.6	100.6
Effective Green, g (s)		36.7	36.7		36.7	36.7	100.6	100.6	100.6	100.6	100.6	100.6
Actuated g/C Ratio		0.24	0.24		0.24	0.24	0.67	0.67	0.67	0.67	0.67	0.67
Clearance Time (s)		6.3	6.3		6.3	6.3	6.4	6.4	6.4	6.4	6.4	6.4
Vehicle Extension (s)		6.0	6.0		6.0	6.0	8.0	8.0	8.0	8.0	8.0	8.0
Lane Grp Cap (vph)		186	347		320	373	205	2306	1031	48	2306	1031
v/s Ratio Prot								c0.69			0.37	
v/s Ratio Perm		0.03	0.00		c0.39	0.20	0.28		0.13	0.35		0.02
v/c Ratio		0.13	0.01		1.58	0.82	0.41	1.02	0.19	0.52	0.55	0.03
Uniform Delay, d1		44.2	42.9		56.6	53.5	11.3	24.7	9.4	12.5	12.9	8.3
Progression Factor		1.00	1.00		1.00	1.00	1.00	1.00	1.00	1.00	1.00	1.00
Incremental Delay, d2		0.9	0.0		277.4	15.0	6.1	24.8	0.4	35.1	1.0	0.1
Delay (s)		45.1	43.0		334.1	68.5	17.3	49.5	9.8	47.6	13.9	8.3
Level of Service		D	D		F	E	B	D	A	D	B	A
Approach Delay (s)		44.1			233.1			44.8			14.3	
Approach LOS		D			F			D			B	

Intersection Summary		
HCM Average Control Delay	67.9	HCM Level of Service E
HCM Volume to Capacity ratio	1.17	
Actuated Cycle Length (s)	150.0	Sum of lost time (s) 12.7
Intersection Capacity Utilization	111.1%	ICU Level of Service H
Analysis Period (min)	15	

c Critical Lane Group

HCM Signalized Intersection Capacity Analysis  
 10: Pendola Point Rd & US 41

7/23/2013



Movement	EBL	EBT	EBR	WBL	WBT	WBR	NBL	NBT	NBR	SEL	SBT	SEB
Lane Configurations	↖	↗			↖	↗	↖	↗	↗	↖	↗	↖
Volume (vph)	57	10	22	108	26	749	17	2205	69	406	1071	75
Ideal Flow (vphpl)	1900	1900	1900	1900	1900	1900	1900	1900	1900	1900	1900	1900
Total Lost time (s)	8.1	8.1			7.1	7.1	7.5	7.5	7.5	7.5	7.5	8.1
Lane Util. Factor	1.00	1.00			1.00	0.88	1.00	0.95	1.00	0.97	0.95	1.00
Frt	1.00	0.90			1.00	0.85	1.00	1.00	0.85	1.00	1.00	0.85
Flt Protected	0.95	1.00			0.96	1.00	0.95	1.00	1.00	0.95	1.00	1.00
Satd. Flow (prot)	1157	1094			1660	2584	1719	3438	1538	3335	3438	1538
Flt Permitted	0.95	1.00			0.74	1.00	0.95	1.00	1.00	0.95	1.00	1.00
Satd. Flow (perm)	1157	1094			1285	2584	1719	3438	1538	3335	3438	1538
Peak-hour factor, PHF	0.95	0.95	0.95	0.95	0.95	0.95	0.95	0.95	0.95	0.95	0.95	0.95
Adj. Flow (vph)	60	11	23	114	27	788	18	2321	73	427	1127	79
RTOR Reduction (vph)	0	0	0	0	0	0	0	0	11	0	0	28
Lane Group Flow (vph)	60	34	0	0	141	788	18	2321	62	427	1127	51
Heavy Vehicles (%)	56%	56%	56%	10%	10%	10%	5%	5%	5%	5%	5%	5%
Turn Type	Prot			Perm		pt+ov	Prot		Perm	Prot		pm+ov
Protected Phases	3	8			4	4 5	1	6		5	2	3
Permitted Phases				4					6			2
Actuated Green, G (s)	9.9	47.0			30.0	54.6	3.7	95.4	95.4	17.5	109.2	119.1
Effective Green, g (s)	9.9	47.0			30.0	54.6	3.7	95.4	95.4	17.5	109.2	119.1
Actuated g/C Ratio	0.05	0.26			0.16	0.30	0.02	0.52	0.52	0.10	0.60	0.65
Clearance Time (s)	8.1	8.1			7.1		7.5	7.5	7.5	7.5	7.5	8.1
Vehicle Extension (s)	6.0	6.0			6.0		6.0	8.0	8.0	6.0	8.0	6.0
Lane Grp Cap (vph)	63	281			211	771	35	1792	802	319	2052	1001
v/s Ratio Prot	c0.05	0.03				c0.30	0.01	c0.68		c0.13	0.33	0.00
v/s Ratio Perm					0.11				0.04			0.03
v/c Ratio	0.95	0.12			0.67	1.02	0.51	1.30	0.08	1.34	0.55	0.05
Uniform Delay, d1	86.3	52.2			71.8	64.2	88.8	43.8	21.8	82.8	22.1	11.5
Progression Factor	1.00	1.00			1.00	1.00	1.00	1.00	1.00	1.00	1.00	1.00
Incremental Delay, d2	98.8	0.5			12.0	38.1	30.0	137.1	0.2	172.1	1.1	0.1
Delay (s)	185.1	52.7			83.8	102.3	118.7	180.9	22.0	254.9	23.2	11.6
Level of Service	F	D			F	F	F	F	C	F	C	B
Approach Delay (s)		137.2			99.5			175.6			83.2	
Approach LOS		F			F			F			F	

Intersection Summary

HCM Average Control Delay	131.2	HCM Level of Service	F
HCM Volume to Capacity ratio	1.26		
Actuated Cycle Length (s)	183.0	Sum of lost time (s)	30.2
Intersection Capacity Utilization	111.1%	ICU Level of Service	H
Analysis Period (min)	15		

c Critical Lane Group

HCM Signalized Intersection Capacity Analysis  
 17: Port Sutton Rd & US 41

7/23/2013



Movement	EBL	EBR	NBL	NBT	SBU	SBT	SBR
Lane Configurations							
Volume (vph)	47	17	32	2759	9	1515	107
Ideal Flow (vphpl)	1900	1900	1900	1900	1900	1900	1900
Total Lost time (s)	7.7	7.0	7.0	6.7	6.4	6.7	7.7
Lane Util. Factor	1.00	1.00	1.00	0.95	1.00	0.95	1.00
Flt	1.00	0.85	1.00	1.00	1.00	1.00	0.85
Flt Protected	0.95	1.00	0.95	1.00	0.95	1.00	1.00
Satd. Flow (prot)	1271	1137	1719	3438	1719	3438	1538
Flt Permitted	0.95	1.00	0.11	1.00	0.04	1.00	1.00
Satd. Flow (perm)	1271	1137	206	3438	66	3438	1538
Peak-hour factor, PHF	0.95	0.95	0.95	0.95	0.95	0.95	0.95
Adj. Flow (vph)	49	18	34	2904	9	1595	113
RTOR Reduction (vph)	0	16	0	0	0	0	19
Lane Group Flow (vph)	49	2	34	2904	9	1595	94
Heavy Vehicles (%)	42%	42%	5%	5%	5%	5%	5%
Turn Type		pm+ov	pm+pt		pm+pt		pm+ov
Protected Phases	8	1	1	6	5	2	8
Permitted Phases		8	6		2		2
Actuated Green, G (s)	13.8	17.7	116.5	112.6	110.1	109.1	122.9
Effective Green, g (s)	13.8	17.7	116.5	112.6	110.1	109.1	122.9
Actuated g/C Ratio	0.09	0.12	0.79	0.76	0.74	0.74	0.83
Clearance Time (s)	7.7	7.0	7.0	6.7	6.4	6.7	7.7
Vehicle Extension (s)	6.0	3.0	3.0	8.0	3.0	8.0	6.0
Lane Grp Cap (vph)	118	136	202	2612	60	2531	1275
v/s Ratio Prot	c0.04	0.00	c0.00	c0.84	0.00	0.46	0.01
v/s Ratio Perm		0.00	0.13		0.11		0.05
v/c Ratio	0.42	0.02	0.17	1.11	0.15	0.63	0.07
Uniform Delay, d1	63.4	57.6	7.1	17.8	42.4	9.6	2.3
Progression Factor	1.00	1.00	1.00	1.00	1.00	1.00	1.00
Incremental Delay, d2	6.6	0.0	0.4	56.4	1.2	1.2	0.1
Delay (s)	69.9	57.6	7.5	74.2	43.5	10.8	2.4
Level of Service	E	E	A	E	D	B	A
Approach Delay (s)	66.6			73.4		10.4	
Approach LOS	E			E		B	

**Intersection Summary**

HCM Average Control Delay	50.4	HCM Level of Service	D
HCM Volume to Capacity ratio	1.04		
Actuated Cycle Length (s)	148.2	Sum of lost time (s)	21.4
Intersection Capacity Utilization	94.1%	ICU Level of Service	F
Analysis Period (min)	15		

c Critical Lane Group

## TWO-WAY STOP CONTROL SUMMARY

Analyst: AG  
 Agency/Co.: American  
 Date Performed: 06/17/2013  
 Analysis Time Period: AM Peak  
 Intersection: Hartford St & US 41  
 Jurisdiction: FDOT D7  
 Units: U. S. Customary  
 Analysis Year: 2030 No Build  
 Project ID: US 41 PD&E Study  
 East/West Street: Hartford St  
 North/South Street: US 41  
 Intersection Orientation: NS Study period (hrs): 0.25

## Vehicle Volumes and Adjustments

Major Street:	Approach Movement	Northbound			Southbound		
		1 L	2 T	3 R	4 L	5 T	6 R

Volume	12	1923	22	93	1133	30	
Peak-Hour Factor, PHF	0.95	0.95	0.95	0.95	0.95	0.95	
Hourly Flow Rate, HFR	12	2024	23	97	1192	31	
Percent Heavy Vehicles	5	--	--	5	--	--	
Median Type/Storage	Raised curb			/ 1			
RT Channelized?							
Lanes		1	2	0	1	2	0
Configuration		L	T	TR	L	T	TR
Upstream Signal?		No			No		

Minor Street:	Approach Movement	Westbound			Eastbound		
		7 L	8 T	9 R	10 L	11 T	12 R

Volume	20	0	101	4	0	3	
Peak Hour Factor, PHF	0.95	0.95	0.95	0.95	0.95	0.95	
Hourly Flow Rate, HFR	21	0	106	4	0	3	
Percent Heavy Vehicles	27	27	27	0	0	0	
Percent Grade (%)		0			0		
Flared Approach: Exists?/Storage		No		/	No		/
Lanes		0	1	0	0	1	0
Configuration		LTR			LTR		

## Delay, Queue Length, and Level of Service

Approach Movement	NB	SB	Westbound			Eastbound		
	1	4	7	8	9	10	11	12

Lane Config	L	L	LTR			LTR		
-------------	---	---	-----	--	--	-----	--	--

v (vph)	12	97	127			7		
C(m) (vph)	549	260				0		
v/c	0.02	0.37						
95% queue length	0.07	1.65						
Control Delay	11.7	26.9						
LOS	B	D				F		
Approach Delay								
Approach LOS								

Arterial Level of Service: NB US 41

Cross Street	Arterial Class	Flow Speed	Running Time	Signal Delay	Travel Time (s)	Dist (mi)	Arterial Speed	Arterial LOS
Symmes Rd		55	134.1	63.0	197.1	2.03	37.0	B
Palm Ave.		42	40.6	31.3	71.9	0.42	21.2	D
Gibsonton Dr		50	42.1	57.9	100.0	0.59	21.1	D
Riverview Dr		50	74.5	49.7	124.2	1.03	30.0	C
CR 676A (Madison Ave		55	181.6	182.2	363.8	2.77	27.5	C
Port Sutton Rd		50	32.5	57.6	90.1	0.36	14.3	F
CR 676		50	83.3	102.7	186.0	1.16	22.4	D
Total			588.7	544.4	1133.1	8.36	26.6	D

Arterial Level of Service: SB US 41

Cross Street	Arterial Class	Flow Speed	Running Time	Signal Delay	Travel Time (s)	Dist (mi)	Arterial Speed	Arterial LOS
Causeway Blvd		50	20.0	87.9	107.9	0.20	6.7	F
Port Sutton Rd		50	83.3	11.5	94.8	1.16	43.9	A
Pendola Point Rd		50	32.5	22.7	55.2	0.36	23.3	D
Industrial Access Rd		55	181.6	14.0	195.6	2.77	51.1	A
Alice Ave		50	74.5	15.3	89.8	1.03	41.5	B
Palm Ave.		50	42.1	4.6	46.7	0.59	45.1	A
Symmes Rd		50	36.3	14.9	51.2	0.42	29.7	C
Total			470.3	170.9	641.2	6.53	36.7	B

TWO-WAY STOP CONTROL SUMMARY

Analyst: AG  
 Agency/Co.: American  
 Date Performed: 06/17/2013  
 Analysis Time Period: PM Peak  
 Intersection: Kracker Avenue & US 41  
 Jurisdiction: FDOT D7  
 Units: U. S. Customary  
 Analysis Year: 2030 No Build  
 Project ID: US 41 PD&E Study  
 East/West Street: Kracker Ave  
 North/South Street: US 41  
 Intersection Orientation: NS  
 Study period (hrs): 0.25

Major Street:	Approach Movement	Vehicle Volumes and Adjustments					
		Northbound			Southbound		
		1 L	2 T	3 R	4 L	5 T	6 R
Volume	8	1105	11	6	2023	4	
Peak-Hour Factor, PHF	0.95	0.95	0.95	0.95	0.95	0.95	
Hourly Flow Rate, HFR	8	1163	11	6	2129	4	
Percent Heavy Vehicles	5	--	--	5	--	--	
Median Type/Storage	Raised curb			/ 1			
RT Channelized?	Yes			Yes			
Lanes	1	2	1	1	2	1	
Configuration	L	T	R	L	T	R	
Upstream Signal?	No			No			

Minor Street:	Approach Movement	Vehicle Volumes and Adjustments					
		Westbound			Eastbound		
		7 L	8 T	9 R	10 L	11 T	12 R
Volume	12	2	12	5	0	5	
Peak Hour Factor, PHF	0.95	0.95	0.95	0.95	0.95	0.95	
Hourly Flow Rate, HFR	12	2	12	5	0	5	
Percent Heavy Vehicles	15	15	15	0	0	0	
Percent Grade (%)	0			0			
Flared Approach: Exists?/Storage	/			/			
Lanes	0	1	1	0	1	1	
Configuration	LT		R	LT		R	

Approach Movement	Delay, Queue Length, and Level of Service							
	NB	SB	Westbound			Eastbound		
	1 L	4 L	7 LT	8 R	9 R	10 LT	11 R	12 R
v (vph)	8	6	14		12	5		5
C(m) (vph)	241	580	82		476	42		273
v/c	0.03	0.01	0.17		0.03	0.12		0.02
95% queue length	0.10	0.03	0.58		0.08	0.38		0.06
Control Delay	20.5	11.3	57.7		12.8	102.0		18.4
LOS	C	B	F		B	F		C
Approach Delay				37.0				60.2
Approach LOS				E				F



## TWO-WAY STOP CONTROL SUMMARY

Analyst: AG  
 Agency/Co.: American  
 Date Performed: 06/17/2013  
 Analysis Time Period: PM Peak  
 Intersection: Ohio Street & US 41  
 Jurisdiction: FDOT D7  
 Units: U. S. Customary  
 Analysis Year: 2030 No Build  
 Project ID: US 41 PD&E Study  
 East/West Street: Ohio St  
 North/South Street: US 41  
 Intersection Orientation: NS

Study period (hrs): 0.25

## Vehicle Volumes and Adjustments

Major Street:	Approach Movement	Northbound			Southbound		
		1 L	2 T	3 R	4 L	5 T	6 R

Volume		1113	17	98	1863	
Peak-Hour Factor, PHF		0.95	0.95	0.95	0.95	
Hourly Flow Rate, HFR		1171	17	103	1961	
Percent Heavy Vehicles		--	--	5	--	--
Median Type/Storage		Raised curb		/ 1		
RT Channelized?						
Lanes		2	0		1 2	
Configuration		T	TR		L T	
Upstream Signal?		No			No	

Minor Street:	Approach Movement	Westbound			Eastbound		
		7 L	8 T	9 R	10 L	11 T	12 R

Volume		21	38	
Peak Hour Factor, PHF		0.95	0.95	
Hourly Flow Rate, HFR		22	40	
Percent Heavy Vehicles		0	0	
Percent Grade (%)		0	0	
Flared Approach: Exists?/Storage		No	/	/
Lanes		0	0	
Configuration		LR		

## Delay, Queue Length, and Level of Service

Approach Movement	NB 1	SB 4 L	Westbound			Eastbound		
			7	8 LR	9	10	11	12

v (vph)		103	62	
C(m) (vph)		567	233	
v/c		0.18	0.27	
95% queue length		0.66	1.04	
Control Delay		12.8	26.0	
LOS		B	D	
Approach Delay			26.0	
Approach LOS			D	

TWO-WAY STOP CONTROL SUMMARY

Analyst: AG  
 Agency/Co.: American  
 Date Performed: 06/17/2013  
 Analysis Time Period: PM Peak  
 Intersection: Florence St & US 41  
 Jurisdiction: FDOT D7  
 Units: U. S. Customary  
 Analysis Year: 2030 No Build  
 Project ID: US 41 PD&E Study  
 East/West Street: Florence St  
 North/South Street: US 41  
 Intersection Orientation: NS  
 Study period (hrs): 0.25

Vehicle Volumes and Adjustments

Major Street: Approach Movement	Northbound			Southbound		
	1 L	2 T	3 R	4 L	5 T	6 R
Volume	12	1077	1	6	1929	17
Peak-Hour Factor, PHF	0.95	0.95	0.95	0.95	0.95	0.95
Hourly Flow Rate, HFR	12	1133	1	6	2030	17
Percent Heavy Vehicles	5	--	--	5	--	--
Median Type/Storage	Raised curb			/ 1		
RT Channelized?						
Lanes Configuration	1 L	2 T	0 TR	1 L	2 T	0 TR
Upstream Signal?	No			No		

Minor Street: Approach Movement	Westbound			Eastbound		
	7 L	8 T	9 R	10 L	11 T	12 R
Volume	4	0	12	20	0	8
Peak Hour Factor, PHF	0.95	0.95	0.95	0.95	0.95	0.95
Hourly Flow Rate, HFR	4	0	12	21	0	8
Percent Heavy Vehicles	0	0	0	0	0	0
Percent Grade (%)	0			0		
Flared Approach: Exists?/Storage	No /			No /		
Lanes Configuration	0	1 L	0 R	0	1 L	0 R
	LTR			LTR		

Delay, Queue Length, and Level of Service

Approach Movement	NB	SB	Westbound			Eastbound		
	1 L	4 L	7 L	8 L	9 L	10 L	11 L	12 L
Lane Config	L	L		LTR			LTR	
v (vph)	12	6	16			29		
C(m) (vph)	260	595	271			64		
v/c	0.05	0.01	0.06			0.45		
95% queue length	0.14	0.03	0.19			1.77		
Control Delay	19.5	11.1	19.1			101.3		
LOS	C	B	C			F		
Approach Delay			19.1			101.3		
Approach LOS			C			F		

HCM Signalized Intersection Capacity Analysis  
 35: Symmes Rd & US 41

7/23/2013



Movement	EBL	EBT	EBR	WBL	WBT	WBR	NBL	NBT	NBR	SBL	SBT	SBR
Lane Configurations		↕		↙	↘			↕	↙	↘	↕	
Volume (vph)	0	2	0	166	0	189	3	966	116	456	1758	4
Ideal Flow (vphpl)	1900	1900	1900	1900	1900	1900	1900	1900	1900	1900	1900	1900
Total Lost time (s)		7.2		7.2	7.2			6.2	6.2	7.0	6.2	
Lane Util. Factor		1.00		1.00	1.00			0.95	1.00	1.00	0.95	
Frt		1.00		1.00	0.85			1.00	0.85	1.00	1.00	
Flt Protected		1.00		0.95	1.00			1.00	1.00	0.95	1.00	
Satd. Flow (prot)		1900		1736	1553			3438	1538	1719	3437	
Flt Permitted		1.00		0.76	1.00			0.95	1.00	0.11	1.00	
Satd. Flow (perm)		1900		1382	1553			3258	1538	208	3437	
Peak-hour factor, PHF	0.95	0.95	0.95	0.95	0.95	0.95	0.95	0.95	0.95	0.95	0.95	0.95
Adj. Flow (vph)	0	2	0	175	0	199	3	1017	122	480	1851	4
RTOR Reduction (vph)	0	0	0	0	0	0	0	0	70	0	0	0
Lane Group Flow (vph)	0	2	0	175	199	0	0	1020	52	480	1855	0
Heavy Vehicles (%)	0%	0%	0%	4%	4%	4%	5%	5%	5%	5%	5%	5%
Turn Type	Perm			Perm			Perm			Perm pm+pt		
Protected Phases	8			4			6			5 2		
Permitted Phases	8			4			6			6 2		
Actuated Green, G (s)	17.7			17.7			37.6			37.6 66.7 66.7		
Effective Green, g (s)	17.7			17.7			37.6			37.6 66.7 66.7		
Actuated g/C Ratio	0.18			0.18			0.38			0.38 0.68 0.68		
Clearance Time (s)	7.2			7.2			6.2			6.2 7.0 6.2		
Vehicle Extension (s)	3.0			3.0			4.0			4.0 3.0 4.0		
Lane Grp Cap (vph)	344			250			1253			591 483 2344		
v/s Ratio Prot	0.00			c0.13						c0.22 0.54		
v/s Ratio Perm				0.13			0.31			0.03 c0.45		
v/c Ratio	0.01			0.70			0.81			0.09 0.99 0.79		
Uniform Delay, d1	32.8			37.6			27.0			19.2 27.7 10.7		
Progression Factor	1.00			1.00			1.00			1.00 1.00 1.00		
Incremental Delay, d2	0.0			8.3			4.4			0.1 39.1 2.0		
Delay (s)	32.8			45.9			31.4			19.3 66.8 12.8		
Level of Service	C			D			C			B E B		
Approach Delay (s)	32.8			45.7			30.1			23.9		
Approach LOS	C			D			C			C		

Intersection Summary

HCM Average Control Delay	27.8	HCM Level of Service	C
HCM Volume to Capacity ratio	0.90		
Actuated Cycle Length (s)	97.8	Sum of lost time (s)	14.2
Intersection Capacity Utilization	107.7%	ICU Level of Service	G
Analysis Period (min)	15		

c Critical Lane Group

HCM Signalized Intersection Capacity Analysis  
 46: Palm Ave. & US 41

7/23/2013



Movement	EBL	EBT	EBR	WBL	WBT	WBR	NBL	NBT	NBR	SBL	SBT	SBR
Lane Configurations		↕		↙	↘		↙	↕	↘	↙	↕	↘
Volume (vph)	32	3	5	18	1	25	6	1215	13	57	2172	23
Ideal Flow (vphpl)	1900	1900	1900	1900	1900	1900	1900	1900	1900	1900	1900	1900
Total Lost time (s)		6.7		6.7	6.7		6.2	6.2	6.2	6.5	6.5	
Lane Util. Factor		1.00		1.00	1.00		1.00	0.95	1.00	1.00	0.95	
Frt		0.98		1.00	0.86		1.00	1.00	0.85	1.00	1.00	
Flt Protected		0.96		0.95	1.00		0.95	1.00	1.00	0.95	1.00	
Satd. Flow (prot)		1728		1805	1626		1719	3438	1538	1719	3433	
Flt Permitted		0.75		0.73	1.00		0.08	1.00	1.00	0.10	1.00	
Satd. Flow (perm)		1345		1386	1626		136	3438	1538	181	3433	
Peak-hour factor, PHF	0.95	0.95	0.95	0.95	0.95	0.95	0.95	0.95	0.95	0.95	0.95	0.95
Adj Flow (vph)	34	3	5	19	1	26	6	1279	14	60	2286	24
RTOR Reduction (vph)	0	0	0	0	0	0	0	0	7	0	0	0
Lane Group Flow (vph)	0	42	0	19	27	0	6	1279	7	60	2310	0
Heavy Vehicles (%)	4%	4%	4%	0%	0%	0%	5%	5%	5%	5%	5%	5%
Turn Type	Perm			Perm			Perm		Perm	pm+pt		
Protected Phases		4			4			2			1	1 2
Permitted Phases	4			4			2		2		1 2	
Actuated Green, G (s)		9.0		9.0	9.0		56.1	56.1	56.1	88.6	95.1	
Effective Green, g (s)		9.0		9.0	9.0		56.1	56.1	56.1	88.6	95.1	
Actuated g/C Ratio		0.08		0.08	0.08		0.48	0.48	0.48	0.76	0.81	
Clearance Time (s)		6.7		6.7	6.7		6.2	6.2	6.2	6.5		
Vehicle Extension (s)		3.0		3.0	3.0		4.0	4.0	4.0	2.5		
Lane Grp Cap (vph)		103		107	125		65	1648	737	564	2790	
v/s Ratio Prot					0.02			0.37		0.03	c0.67	
v/s Ratio Perm		c0.03		0.01			0.04		0.00	0.05		
v/c Ratio		0.41		0.18	0.22		0.09	0.78	0.01	0.11	0.83	
Uniform Delay, d1		51.5		50.5	50.7		16.6	25.2	15.9	8.2	6.3	
Progression Factor		1.00		1.00	1.00		1.00	1.00	1.00	1.00	1.00	
Incremental Delay, d2		2.6		0.8	0.9		0.8	2.5	0.0	0.1	2.1	
Delay (s)		54.1		51.3	51.6		17.4	27.7	15.9	8.2	8.4	
Level of Service		D		D	D		B	C	B	A	A	
Approach Delay (s)		54.1			51.5			27.6			8.4	
Approach LOS		D			D			C			A	

Intersection Summary		
HCM Average Control Delay	16.0	HCM Level of Service
HCM Volume to Capacity ratio	0.79	B
Actuated Cycle Length (s)	117.0	Sum of lost time (s)
Intersection Capacity Utilization	80.7%	13.2
Analysis Period (min)	15	ICU Level of Service
		D

c Critical Lane Group

## TWO-WAY STOP CONTROL SUMMARY

Analyst: AG  
 Agency/Co.: American  
 Date Performed: 06/17/2013  
 Analysis Time Period: PM Peak  
 Intersection: Nundy Ave & US 41  
 Jurisdiction: FDOT D7  
 Units: U. S. Customary  
 Analysis Year: 2030 No Buuild  
 Project ID: US 41 PD&E Study  
 East/West Street: Nundy Ave  
 North/South Street: US 41  
 Intersection Orientation: NS

Study period (hrs): 0.25

## Vehicle Volumes and Adjustments

Major Street:	Approach Movement	Northbound			Southbound		
		1 L	2 T	3 R	4 L	5 T	6 R

Volume	14	1170	68	61	2173	9
Peak-Hour Factor, PHF	0.95	0.95	0.95	0.95	0.95	0.95
Hourly Flow Rate, HFR	14	1231	71	64	2287	9
Percent Heavy Vehicles	5	--	--	5	--	--
Median Type/Storage	Raised curb			/ 1		
RT Channelized?						
Lanes	1	2	0	1	2	0
Configuration	L	T	TR	L	T	TR
Upstream Signal?	No			Yes		

Minor Street:	Approach Movement	Westbound			Eastbound		
		7 L	8 T	9 R	10 L	11 T	12 R

Volume	79	3	42	5	0	18
Peak Hour Factor, PHF	0.95	0.95	0.95	0.95	0.95	0.95
Hourly Flow Rate, HFR	83	3	44	5	0	18
Percent Heavy Vehicles	3	3	3	0	0	0
Percent Grade (%)	0		0			
Flared Approach: Exists?/Storage			No	/	No /	
Lanes	0	1	0	0	1	0
Configuration	LTR			LTR		

## Delay, Queue Length, and Level of Service

Approach Movement	NB	SB	Westbound			Eastbound		
			7	8	9	10	11	12

Lane Config	L	L	LTR			LTR		
v (vph)	14	64	130			23		
C(m) (vph)	248	512	128			136		
v/c	0.06	0.13	1.02			0.17		
95% queue length	0.18	0.43	7.11			0.59		
Control Delay	20.4	13.0	150.1			36.8		
LOS	C	B	F			E		
Approach Delay			150.1			36.8		
Approach LOS			F			E		

HCM Signalized Intersection Capacity Analysis  
 40: Alice Ave & US 41

7/23/2013



Movement	EBL	EBT	EBR	WBL	WBT	WBR	NBL	NBT	NBR	SBL	SBT	SBR
Lane Configurations		↕		↗	↖	↗	↖	↕	↗	↖	↕	
Volume (vph)	11	24	17	451	61	188	13	855	379	596	1946	20
Ideal Flow (vphpl)	1900	1900	1900	1900	1900	1900	1900	1900	1900	1900	1900	1900
Total Lost time (s)		9.0		9.0	9.0	6.7	6.1	6.1	6.1	6.7	6.1	
Lane Util. Factor		1.00		1.00	1.00	1.00	1.00	0.95	1.00	1.00	0.95	
Frt		0.96		1.00	1.00	0.85	1.00	1.00	0.85	1.00	1.00	
Flt Protected		0.99		0.95	1.00	1.00	0.95	1.00	1.00	0.95	1.00	
Satd. Flow (prot)		1695		1719	1810	1538	1719	3438	1538	1719	3433	
Flt Permitted		0.94		0.72	1.00	1.00	0.09	1.00	1.00	0.09	1.00	
Satd. Flow (perm)		1613		1305	1810	1538	165	3438	1538	157	3433	
Peak-hour factor, PHF	0.95	0.95	0.95	0.95	0.95	0.95	0.95	0.95	0.95	0.95	0.95	0.95
Adj. Flow (vph)	12	25	18	475	64	198	14	900	399	627	2048	21
RTOR Reduction (vph)	0	0	0	0	0	0	0	0	155	0	0	0
Lane Group Flow (vph)	0	55	0	475	64	198	14	900	244	627	2069	0
Heavy Vehicles (%)	6%	6%	6%	5%	5%	5%	5%	5%	5%	5%	5%	5%
Turn Type	Perm			Perm		pm+ov	Perm		Perm	pm+pt		
Protected Phases		8			4	5		6		5	2	
Permitted Phases	8			4		4	6		6		2	
Actuated Green, G (s)		43.0		43.0	43.0	79.3	43.9	43.9	43.9	86.9	86.9	
Effective Green, g (s)		43.0		43.0	43.0	79.3	43.9	43.9	43.9	86.9	86.9	
Actuated g/C Ratio		0.30		0.30	0.30	0.55	0.30	0.30	0.30	0.60	0.60	
Clearance Time (s)		9.0		9.0	9.0	6.7	6.1	6.1	6.1	6.7	6.1	
Vehicle Extension (s)		3.0		6.0	6.0	3.0	8.0	8.0	8.0	3.0	8.0	
Lane Grp Cap (vph)		478		387	537	841	50	1041	466	485	2057	
v/s Ratio Prot					0.04	0.06		0.26		c0.32	0.60	
v/s Ratio Perm		0.03		c0.36		0.07	0.08		0.16	c0.45		
v/c Ratio		0.12		1.23	0.12	0.24	0.28	0.86	0.52	1.29	1.01	
Uniform Delay, d1		37.1		51.0	37.2	17.1	38.5	47.7	41.9	44.9	29.0	
Progression Factor		1.00		1.00	1.00	1.00	1.00	1.00	1.00	1.00	1.00	
Incremental Delay, d2		0.5		123.2	0.5	0.7	13.4	9.5	4.2	146.5	21.3	
Delay (s)		37.6		174.2	37.6	17.7	52.0	57.3	46.1	191.4	50.3	
Level of Service		D		F	D	B	D	E	D	F	D	
Approach Delay (s)		37.6			120.3			53.8			83.1	
Approach LOS		D			F			D			F	

Intersection Summary

HCM Average Control Delay	80.3	HCM Level of Service	F
HCM Volume to Capacity ratio	1.24		
Actuated Cycle Length (s)	145.0	Sum of lost time (s)	15.7
Intersection Capacity Utilization	116.2%	ICU Level of Service	H
Analysis Period (min)	15		

c Critical Lane Group

HCM Signalized Intersection Capacity Analysis  
 9: Industrial Access Rd & US 41

7/23/2013



Movement	EBL	EBT	EBR	WBL	WBT	WBR	NBL	NBT	NBR	SBL	SBT	SBR
Lane Configurations		↖	↗		↖	↗	↘	↕	↗	↘	↕	↗
Volume (vph)	29	49	59	516	11	50	20	1002	403	137	2139	15
Ideal Flow (vphpl)	1900	1900	1900	1900	1900	1900	1900	1900	1900	1900	1900	1900
Total Lost time (s)		6.3	6.3		6.3	6.3	6.4	6.4	6.4	6.4	6.4	6.4
Lane Util. Factor		1.00	1.00		1.00	1.00	1.00	0.95	1.00	1.00	0.95	1.00
Frt		1.00	0.85		1.00	0.85	1.00	1.00	0.85	1.00	1.00	0.85
Flt Protected		0.98	1.00		0.95	1.00	0.95	1.00	1.00	0.95	1.00	1.00
Satd. Flow (prot)		1847	1599		1776	1583	1719	3438	1538	1719	3438	1538
Flt Permitted		0.23	1.00		0.67	1.00	0.04	1.00	1.00	0.22	1.00	1.00
Satd. Flow (perm)		441	1599		1249	1583	77	3438	1538	396	3438	1538
Peak-hour factor, PHF	0.95	0.95	0.95	0.95	0.95	0.95	0.95	0.95	0.95	0.95	0.95	0.95
Adj. Flow (vph)	31	52	62	543	12	53	21	1055	424	144	2252	16
RTOR Reduction (vph)	0	0	6	0	0	16	0	0	157	0	0	4
Lane Group Flow (vph)	0	83	56	0	555	37	21	1055	267	144	2252	12
Heavy Vehicles (%)	1%	1%	1%	2%	2%	2%	5%	5%	5%	5%	5%	5%
Turn Type	Perm		Perm	Perm		Perm	Perm		Perm	Perm		Perm
Protected Phases		4			4			2				2
Permitted Phases	4		4	4		4	2		2	2		2
Actuated Green, G (s)		42.7	42.7		42.7	42.7	94.6	94.6	94.6	94.6	94.6	94.6
Effective Green, g (s)		42.7	42.7		42.7	42.7	94.6	94.6	94.6	94.6	94.6	94.6
Actuated g/C Ratio		0.28	0.28		0.28	0.28	0.63	0.63	0.63	0.63	0.63	0.63
Clearance Time (s)		6.3	6.3		6.3	6.3	6.4	6.4	6.4	6.4	6.4	6.4
Vehicle Extension (s)		6.0	6.0		6.0	6.0	8.0	8.0	8.0	8.0	8.0	8.0
Lane Grp Cap (vph)		126	455		356	451	49	2168	970	250	2168	970
v/s Ratio Prot								0.31			c0.66	
v/s Ratio Perm		0.19	0.04		c0.44	0.02	0.27		0.17	0.36		0.01
v/c Ratio		0.66	0.12		1.56	0.08	0.43	0.49	0.28	0.58	1.04	0.01
Uniform Delay, d1		47.2	39.8		53.6	39.3	14.0	14.8	12.4	16.1	27.7	10.3
Progression Factor		1.00	1.00		1.00	1.00	1.00	1.00	1.00	1.00	1.00	1.00
Incremental Delay, d2		18.2	0.3		264.9	0.2	25.1	0.8	0.7	9.3	30.3	0.0
Delay (s)		65.5	40.1		318.6	39.5	39.1	15.5	13.1	25.4	58.0	10.3
Level of Service		E	D		F	D	D	B	B	C	E	B
Approach Delay (s)		54.6			294.3			15.2			55.7	
Approach LOS		D			F			B			E	

Intersection Summary

HCM Average Control Delay	73.7	HCM Level of Service	E
HCM Volume to Capacity ratio	1.20		
Actuated Cycle Length (s)	150.0	Sum of lost time (s)	12.7
Intersection Capacity Utilization	123.4%	ICU Level of Service	H
Analysis Period (min)	15		

c Critical Lane Group

# HCM Signalized Intersection Capacity Analysis

## 10: Pendola Point Rd & US 41

7/23/2013



Movement	EBL	EBT	EBR	WBL	WBT	WBR	NBL	NBT	NBR	SBL	SBT	SBR
Lane Configurations	↖	↗			↖	↗	↖	↗	↗	↖	↗	↗
Volume (vph)	118	56	12	156	0	284	2	1208	63	542	2243	7
Ideal Flow (vphpl)	1900	1900	1900	1900	1900	1900	1900	1900	1900	1900	1900	1900
Total Lost time (s)	8.1	8.1			7.1	7.1	7.5	7.5	7.5	7.5	7.5	8.1
Lane Util. Factor	1.00	1.00			1.00	0.88	1.00	0.95	1.00	0.97	0.95	1.00
Fr't	1.00	0.97			1.00	0.85	1.00	1.00	0.85	1.00	1.00	0.85
Flt Protected	0.95	1.00			0.95	1.00	0.95	1.00	1.00	0.95	1.00	1.00
Satd. Flow (prot)	1583	1622			1656	2608	1719	3438	1538	3335	3438	1538
Flt Permitted	0.95	1.00			0.71	1.00	0.95	1.00	1.00	0.95	1.00	1.00
Satd. Flow (perm)	1583	1622			1238	2608	1719	3438	1538	3335	3438	1538
Peak-hour factor, PHF	0.95	0.95	0.95	0.95	0.95	0.95	0.95	0.95	0.95	0.95	0.95	0.95
Adj. Flow (vph)	124	59	13	164	0	299	2	1272	66	571	2361	7
RTOR Reduction (vph)	0	0	0	0	0	0	0	0	18	0	0	1
Lane Group Flow (vph)	124	72	0	0	164	299	2	1272	48	571	2361	6
Heavy Vehicles (%)	14%	14%	14%	9%	9%	9%	5%	5%	5%	5%	5%	5%
Turn Type	Prot			Perm		pt+ov	Prot		Perm	Prot		pm+ov
Protected Phases	3	8			4	4.5	1	6		5	2	3
Permitted Phases				4					6			2
Actuated Green, G (s)	16.8	46.9			23.0	64.4	1.0	81.4	81.4	34.3	114.7	131.5
Effective Green, g (s)	16.8	46.9			23.0	64.4	1.0	81.4	81.4	34.3	114.7	131.5
Actuated g/C Ratio	0.09	0.25			0.12	0.35	0.01	0.44	0.44	0.18	0.62	0.71
Clearance Time (s)	8.1	8.1			7.1		7.5	7.5	7.5	7.5	7.5	8.1
Vehicle Extension (s)	6.0	6.0			6.0		6.0	8.0	8.0	6.0	8.0	6.0
Lane Grp Cap (vph)	143	410			153	904	9	1507	674	616	2124	1089
v/s Ratio Prot	c0.08	0.04				0.11	0.00	0.37		c0.17	c0.69	0.00
v/s Ratio Perm					c0.13				0.03			0.00
v/c Ratio	0.87	0.18			1.07	0.33	0.22	0.84	0.07	0.93	1.11	0.01
Uniform Delay, d1	83.3	54.3			81.3	44.7	92.0	46.5	30.2	74.5	35.5	7.9
Progression Factor	1.00	1.00			1.00	1.00	1.00	1.00	1.00	1.00	1.00	1.00
Incremental Delay, d2	42.7	0.6			93.2	0.6	32.4	6.0	0.2	21.4	57.6	0.0
Delay (s)	126.1	54.9			174.6	45.4	124.4	52.5	30.4	95.9	93.1	7.9
Level of Service	F	D			F	D	F	D	C	F	F	A
Approach Delay (s)		99.9			91.1			51.5			93.4	
Approach LOS		F			F			D			F	

### Intersection Summary

HCM Average Control Delay	82.1	HCM Level of Service	F
HCM Volume to Capacity ratio	1.11		
Actuated Cycle Length (s)	185.7	Sum of lost time (s)	30.2
Intersection Capacity Utilization	99.9%	ICU Level of Service	F
Analysis Period (min)	15		

c Critical Lane Group



HCM Signalized Intersection Capacity Analysis  
 17: Port Sutton Rd & US 41

7/23/2013



Movement	EBL	EBR	NBL	NBT	SBU	SBT	SBR
Lane Configurations							
Volume (vph)	116	82	0	1552	2	2913	5
Ideal Flow (vphpl)	1900	1900	1900	1900	1900	1900	1900
Total Lost time (s)	7.7	7.0		6.7	6.4	6.7	7.7
Lane Util. Factor	1.00	1.00		0.95	1.00	0.95	1.00
Fr't	1.00	0.85		1.00	1.00	1.00	0.85
Flt Protected	0.95	1.00		1.00	0.95	1.00	1.00
Satd. Flow (prot)	1805	1615		3438	1719	3438	1538
Flt Permitted	0.95	1.00		1.00	0.12	1.00	1.00
Satd. Flow (perm)	1805	1615		3438	210	3438	1538
Peak-hour factor, PHF	0.95	0.95	0.95	0.95	0.95	0.95	0.95
Adj. Flow (vph)	122	86	0	1634	2	3066	5
RTOR Reduction (vph)	0	1	0	0	0	0	1
Lane Group Flow (vph)	122	85	0	1634	2	3066	4
Heavy Vehicles (%)	0%	0%	5%	5%	5%	5%	5%
Turn Type		pm+ov	pm+pt		pm+pt		pm+ov
Protected Phases	8	1	1	6	5	2	8
Permitted Phases		8	6		2		2
Actuated Green, G (s)	18.1	23.1		114.1	110.7	109.6	127.7
Effective Green, g (s)	18.1	23.1		114.1	110.7	109.6	127.7
Actuated g/C Ratio	0.12	0.15		0.74	0.72	0.71	0.83
Clearance Time (s)	7.7	7.0		6.7	6.4	6.7	7.7
Vehicle Extension (s)	6.0	3.0		8.0	3.0	8.0	6.0
Lane Grp Cap (vph)	212	242		2546	162	2445	1275
v/s Ratio Prot	c0.07	c0.01		c0.48	0.00	c0.89	0.00
v/s Ratio Perm		0.04			0.01		0.00
v/c Ratio	0.58	0.35		0.64	0.01	1.25	0.00
Uniform Delay, d1	64.4	58.8		9.9	8.2	22.2	2.3
Progression Factor	1.00	1.00		1.00	1.00	1.00	1.00
Incremental Delay, d2	7.3	0.9		1.3	0.0	117.8	0.0
Delay (s)	71.7	59.7		11.1	8.3	140.1	2.3
Level of Service	E	E		B	A	F	A
Approach Delay (s)	66.7			11.1		139.8	
Approach LOS	E			B		F	

**Intersection Summary**

HCM Average Control Delay	93.9	HCM Level of Service	F
HCM Volume to Capacity ratio	1.20		
Actuated Cycle Length (s)	154.1	Sum of lost time (s)	28.1
Intersection Capacity Utilization	98.9%	ICU Level of Service	F
Analysis Period (min)	15		

c Critical Lane Group

## TWO-WAY STOP CONTROL SUMMARY

Analyst: AG  
 Agency/Co.: American  
 Date Performed: 06/17/2013  
 Analysis Time Period: PM Peak  
 Intersection: Hartford St & US 41  
 Jurisdiction: FDOT D7  
 Units: U. S. Customary  
 Analysis Year: 2030 No Build  
 Project ID: US 41 PD&E Study  
 East/West Street: Hartford St  
 North/South Street: US 41  
 Intersection Orientation: NS

Study period (hrs): 0.25

## Vehicle Volumes and Adjustments

Major Street:	Approach Movement	Northbound			Southbound		
		1 L	2 T	3 R	4 L	5 T	6 R

Volume	10	1054	31	58	2144	3
Peak-Hour Factor, PHF	0.95	0.95	0.95	0.95	0.95	0.95
Hourly Flow Rate, HFR	10	1109	32	61	2256	3
Percent Heavy Vehicles	5	--	--	5	--	--
Median Type/Storage	Raised curb			/ 1		
RT Channelized?						
Lanes	1	2	0	1	2	0
Configuration	L	T	TR	L	T	TR
Upstream Signal?	No			No		

Minor Street:	Approach Movement	Westbound			Eastbound		
		7 L	8 T	9 R	10 L	11 T	12 R

Volume	29	0	85	15	0	8
Peak Hour Factor, PHF	0.95	0.95	0.95	0.95	0.95	0.95
Hourly Flow Rate, HFR	30	0	89	15	0	8
Percent Heavy Vehicles	13	13	13	10	10	10
Percent Grade (%)	0				0	
Flared Approach: Exists?/Storage	No		/		No /	
Lanes	0	1	0	0	1	0
Configuration	LTR			LTR		

## Delay, Queue Length, and Level of Service

Approach Movement	NB 1 L	SB 4 L	Westbound			Eastbound		
			7	8 LTR	9	10	11 LTR	12

v (vph)	10	61	119			23			
C(m) (vph)	214	591	208			35			
v/c	0.05	0.10	0.57			0.66			
95% queue length	0.15	0.34	3.13			2.28			
Control Delay	22.6	11.8	43.2			221.4			
LOS	C	B	E			F			
Approach Delay				43.2			221.4		
Approach LOS				E			F		

Arterial Level of Service: NB US 41

Cross Street	Arterial Class	Flow Speed	Running Time	Signal Delay	Travel Time (s)	Dist (mi)	Arterial Speed	Arterial LOS
Symmes Rd	I	55	134.1	34.2	168.3	2.03	43.4	A
Palm Ave.	I	42	40.6	29.6	70.2	0.42	21.7	D
Gibsonton Dr	I	50	42.1	57.6	99.7	0.59	21.1	D
Riverview Dr	I	50	74.5	15.7	90.2	1.03	41.3	B
CR 676A (Madison Ave)	I	55	181.6	56.6	238.2	2.77	41.9	B
Port Sutton Rd	I	50	32.5	10.1	42.6	0.36	30.2	C
CR 676	I	50	83.3	138.3	221.6	1.16	18.8	E
Total	I		588.7	342.1	930.8	8.36	32.3	C

Arterial Level of Service: SB US 41

Cross Street	Arterial Class	Flow Speed	Running Time	Signal Delay	Travel Time (s)	Dist (mi)	Arterial Speed	Arterial LOS
Causeway Blvd	I	50	20.0	258.2	278.2	0.20	2.6	F
Port Sutton Rd	I	50	83.3	149.8	233.1	1.16	17.9	E
Pendola Point Rd	I	50	32.5	75.0	107.5	0.36	12.0	F
Industrial Access Rd	I	55	181.6	58.0	239.6	2.77	41.7	B
Alice Ave	I	50	74.5	50.3	124.8	1.03	29.9	C
Palm Ave.	I	50	42.1	10.4	52.5	0.59	40.1	B
Symmes Rd	I	50	36.3	14.9	51.2	0.42	29.7	C
Total	I		470.3	616.6	1086.9	6.53	21.6	D

TWO-WAY STOP CONTROL SUMMARY

Analyst: AG  
 Agency/Co.: American  
 Date Performed: 07/15/2013  
 Analysis Time Period: AM Peak  
 Intersection: Kracker Avenue & US 41  
 Jurisdiction: FDOT D7  
 Units: U. S. Customary  
 Analysis Year: 2030 Build  
 Project ID: US 41 PD&E Study  
 East/West Street: Kracker Ave  
 North/South Street: US 41  
 Intersection Orientation: NS

Study period (hrs): 0.25

		Vehicle Volumes and Adjustments					
Major Street:	Approach Movement	Northbound			Southbound		
		1 L	2 T	3 R	4 L	5 T	6 R
Volume		7	1339	9	2	750	3
Peak-Hour Factor, PHF		0.95	0.95	0.95	0.95	0.95	0.95
Hourly Flow Rate, HFR		7	1409	9	2	789	3
Percent Heavy Vehicles		5	--	--	5	--	--
Median Type/Storage		Raised curb			/ 1		
RT Channelized?							
Lanes		1	2	0	1	2	0
Configuration		L	T	TR	L	T	TR
Upstream Signal?		No			No		

		Westbound			Eastbound		
Minor Street:	Approach Movement	7	8	9	10	11	12
		L	T	R	L	T	R
Volume		20	0	8	7	0	11
Peak Hour Factor, PHF		0.95	0.95	0.95	0.95	0.95	0.95
Hourly Flow Rate, HFR		21	0	8	7	0	11
Percent Heavy Vehicles		0	0	0	0	0	0
Percent Grade (%)		0			0		
Flared Approach: Exists?/Storage					/		
Lanes		0	1	1	0	1	1
Configuration		LT		R	LT		R

		Delay, Queue Length, and Level of Service					
Approach Movement	Lane Config	NB	SB	Westbound		Eastbound	
		1 L	4 L	7 LT	8 R	9 LT	10 11 R
v (vph)		7	2	21	8	7	11
C(m) (vph)		805	461	117	438	203	658
v/c		0.01	0.00	0.18	0.02	0.03	0.02
95% queue length		0.03	0.01	0.62	0.06	0.11	0.05
Control Delay		9.5	12.8	42.4	13.4	23.4	10.6
LOS		A	B	E	B	C	B
Approach Delay					34.4	15.5	
Approach LOS					D	C	

## TWO-WAY STOP CONTROL SUMMARY

Analyst: AG  
 Agency/Co.: American  
 Date Performed: 07/15/2013  
 Analysis Time Period: AM Peak  
 Intersection: Ohio Street & US 41  
 Jurisdiction: FDOT D7  
 Units: U. S. Customary  
 Analysis Year: 2030 Build  
 Project ID: US 41 PD&E Study  
 East/West Street: Ohio St  
 North/South Street: US 41  
 Intersection Orientation: NS

Study period (hrs): 0.25

Major Street:	Approach Movement	Vehicle Volumes and Adjustments					
		Northbound			Southbound		
		1	2	3	4	5	6
		L	T	R	L	T	R
Volume			1343	19	69	681	
Peak-Hour Factor, PHF			0.95	0.95	0.95	0.95	
Hourly Flow Rate, HFR			1413	20	72	716	
Percent Heavy Vehicles			--	--	5	--	--
Median Type/Storage			Raised curb		/ 1		
RT Channelized?							
Lanes			2	0		1 2	
Configuration			T	TR		L T	
Upstream Signal?			No			No	

Minor Street:	Approach Movement	Vehicle Volumes and Adjustments					
		Westbound			Eastbound		
		7	8	9	10	11	12
		L	T	R	L	T	R
Volume		36		36			
Peak Hour Factor, PHF		0.95		0.95			
Hourly Flow Rate, HFR		37		37			
Percent Heavy Vehicles		16		16			
Percent Grade (%)			0			0	
Flared Approach: Exists?/Storage					/		/
Lanes		1		1			
Configuration		L		R			

Approach	Delay, Queue Length, and Level of Service								
	NB	SB	Westbound			Eastbound			
Movement	1	4	7	8	9	10	11	12	
Lane Config		L	L		R				
v (vph)		72	37		37				
C(m) (vph)		455	125		394				
v/c		0.16	0.30		0.09				
95% queue length		0.56	1.14		0.31				
Control Delay		14.4	45.5		15.1				
LOS		B	E		C				
Approach Delay				30.3					
Approach LOS				D					

## TWO-WAY STOP CONTROL SUMMARY

Analyst: AG  
 Agency/Co.: American  
 Date Performed: 07/15/2013  
 Analysis Time Period: AM Peak  
 Intersection: Florence St & US 41  
 Jurisdiction: FDOT D7  
 Units: U. S. Customary  
 Analysis Year: 2030 Build  
 Project ID: US 41 PD&E Study  
 East/West Street: Florence St  
 North/South Street: US 41  
 Intersection Orientation: NS

Study period (hrs): 0.25

## Vehicle Volumes and Adjustments

Major Street:	Approach Movement	Northbound			Southbound		
		1 L	2 T	3 R	4 L	5 T	6 R
Volume		7	1303	0	3	709	19
Peak-Hour Factor, PHF		0.95	0.95	0.95	0.95	0.95	0.95
Hourly Flow Rate, HFR		7	1371	0	3	746	20
Percent Heavy Vehicles		5	--	--	5	--	--
Median Type/Storage		Raised curb			/ 1		
RT Channelized?							
Lanes		1	2	0	1	2	0
Configuration		L	T	TR	L	T	TR
Upstream Signal?		No			No		

Minor Street:	Approach Movement	Westbound			Eastbound		
		7 L	8 T	9 R	10 L	11 T	12 R
Volume		7	0	15	15	0	9
Peak Hour Factor, PHF		0.95	0.95	0.95	0.95	0.95	0.95
Hourly Flow Rate, HFR		7	0	15	15	0	9
Percent Heavy Vehicles		0	0	0	0	0	0
Percent Grade (%)		0			0		
Flared Approach: Exists?/Storage		No			/ No /		
Lanes		0	1	0	0	1	0
Configuration		LTR			LTR		

## Delay, Queue Length, and Level of Service

Approach Movement	NB 1 L	SB 4 L	Westbound			Eastbound		
			7	8 LTR	9	10	11 LTR	12
Lane Config								
v (vph)	7	3	22			24		
C(m) (vph)	824	481	248			284		
v/c	0.01	0.01	0.09			0.08		
95% queue length	0.03	0.02	0.29			0.27		
Control Delay	9.4	12.5	20.9			18.8		
LOS	A	B	C			C		
Approach Delay			20.9			18.8		
Approach LOS			C			C		

HCM Signalized Intersection Capacity Analysis  
 35: Symmes Rd & US 41

7/23/2013

Movement	EBL	EBT	EBR	WBL	WBT	WBR	NBL	NBT	NBR	SBL	SBT	SBR
Lane Configurations		↕		↕	↕	↕	↕	↕	↕	↕	↕	↕
Volume (vph)	1	0	0	240	0	563	15	1748	189	180	1053	0
Ideal Flow (vphpl)	1900	1900	1900	1900	1900	1900	1900	1900	1900	1900	1900	1900
Total Lost time (s)		7.2		7.2	7.2	7.2	6.2	6.2	7.2	7.0	6.2	
Lane Util. Factor		1.00		0.97	0.95	0.95	1.00	0.91	1.00	0.97	0.91	
Frt		1.00		1.00	0.85	0.85	1.00	1.00	0.85	1.00	1.00	
Flt Protected		0.95		0.95	1.00	1.00	0.95	1.00	1.00	0.95	1.00	
Satd. Flow (prot)		1805		3303	1447	1447	1719	4940	1538	3335	4940	
Flt Permitted		1.00		0.95	1.00	1.00	0.95	1.00	1.00	0.95	1.00	
Satd. Flow (perm)		1900		3303	1447	1447	1719	4940	1538	3335	4940	
Peak-hour factor, PHF	0.95	0.95	0.95	0.95	0.95	0.95	0.95	0.95	0.95	0.95	0.95	0.95
Adj. Flow (vph)	1	0	0	253	0	593	16	1840	199	189	1108	0
RTOR Reduction (vph)	0	0	0	0	0	0	0	0	77	0	0	0
Lane Group Flow (vph)	0	1	0	253	297	296	16	1840	122	189	1108	0
Heavy Vehicles (%)	0%	0%	0%	6%	6%	6%	5%	5%	5%	5%	5%	5%
Turn Type	Perm			Prot		pt+ov	Prot		pm+ov	Prot		
Protected Phases		8		7	4	4 5	1	6	7	5	2	
Permitted Phases	8								6			
Actuated Green, G (s)		1.3		16.5	25.0	37.2	0.8	37.3	53.8	5.0	42.3	
Effective Green, g (s)		1.3		16.5	25.0	37.2	0.8	37.3	53.8	5.0	42.3	
Actuated g/C Ratio		0.01		0.19	0.29	0.42	0.01	0.43	0.61	0.06	0.48	
Clearance Time (s)		7.2		7.2	7.2		6.2	6.2	7.2	7.0	6.2	
Vehicle Extension (s)		3.0		3.0	3.0		3.0	4.0	3.0	3.0	4.0	
Lane Grp Cap (vph)		28		621	412	614	16	2101	943	190	2383	
v/s Ratio Prot				0.08	c0.21	c0.20	0.01	c0.37	0.02	c0.06	c0.22	
v/s Ratio Perm		0.00							0.06			
v/c Ratio		0.04		0.41	0.72	0.48	1.00	0.88	0.13	0.99	0.46	
Uniform Delay, d1		42.6		31.3	28.2	18.3	43.5	23.1	7.1	41.3	15.1	
Progression Factor		1.00		1.00	1.00	1.00	1.00	1.00	1.00	1.00	1.00	
Incremental Delay, d2		0.5		0.4	6.1	0.6	225.0	4.6	0.1	63.4	0.2	
Delay (s)		43.1		31.7	34.3	18.9	268.4	27.6	7.2	104.8	15.3	
Level of Service		D		C	C	B	F	C	A	F	B	
Approach Delay (s)		43.1			28.1			27.5			28.4	
Approach LOS		D			C			C			C	

Intersection Summary			
HCM Average Control Delay	27.9	HCM Level of Service	C
HCM Volume to Capacity ratio	0.94		
Actuated Cycle Length (s)	87.7	Sum of lost time (s)	26.6
Intersection Capacity Utilization	80.0%	ICU Level of Service	D
Analysis Period (min)	15		

c Critical Lane Group

HCM Signalized Intersection Capacity Analysis  
 46: Palm Ave. & US 41

7/23/2013



Movement	EBL	EBT	EBR	WBL	WBT	WBR	NBL	NBT	NBR	SBL	SBT	SBR
Lane Configurations		↕		↗	↖		↗	↕		↖	↕	↖
Volume (vph)	40	0	19	3	0	24	4	2206	8	36	1210	6
Ideal Flow (vphpl)	1900	1900	1900	1900	1900	1900	1900	1900	1900	1900	1900	1900
Total Lost time (s)		6.7		6.7	6.7		6.2	6.2		6.5	6.2	
Lane Util. Factor		1.00		1.00	1.00		1.00	0.91		1.00	0.91	
Frt		0.96		1.00	0.85		1.00	1.00		1.00	1.00	
Flt Protected		0.97		0.95	1.00		0.95	1.00		0.95	1.00	
Satd. Flow (prot)		1758		1805	1615		1719	4937		1719	4937	
Flt Permitted		0.78		0.72	1.00		0.95	1.00		0.95	1.00	
Satd. Flow (perm)		1420		1362	1615		1719	4937		1719	4937	
Peak-hour factor, PHF	0.95	0.95	0.95	0.95	0.95	0.95	0.95	0.95	0.95	0.95	0.95	0.95
Adj. Flow (vph)	42	0	20	3	0	25	4	2322	8	38	1274	6
RTOR Reduction (vph)	0	0	0	0	0	0	0	0	0	0	0	0
Lane Group Flow (vph)	0	62	0	3	25	0	4	2330	0	38	1280	0
Heavy Vehicles (%)	0%	0%	0%	0%	0%	0%	5%	5%	5%	5%	5%	5%
Turn Type	Perm			Perm			Prot			Prot		
Protected Phases		8			4		1	6		5	2	
Permitted Phases	8			4								
Actuated Green, G (s)		8.8		8.8	8.8		5.4	38.9		2.7	36.5	
Effective Green, g (s)		8.8		8.8	8.8		5.4	38.9		2.7	36.5	
Actuated g/C Ratio		0.13		0.13	0.13		0.08	0.56		0.04	0.52	
Clearance Time (s)		6.7		6.7	6.7		6.2	6.2		6.5	6.2	
Vehicle Extension (s)		3.0		3.0	3.0		4.0	4.0		2.5	4.0	
Lane Grp Cap (vph)		179		172	204		133	2751		66	2582	
v/s Ratio Prot					0.02		0.00	c0.47		c0.02	0.26	
v/s Ratio Perm		c0.04		0.00								
v/c Ratio		0.35		0.02	0.12		0.03	0.85		0.58	0.50	
Uniform Delay, d1		27.9		26.7	27.1		29.8	13.0		33.0	10.7	
Progression Factor		1.00		1.00	1.00		1.00	1.00		1.00	1.00	
Incremental Delay, d2		1.2		0.0	0.3		0.1	2.7		9.6	0.2	
Delay (s)		29.0		26.8	27.3		29.9	15.7		42.6	10.9	
Level of Service		C		C	C		C	B		D	B	
Approach Delay (s)		29.0			27.3			15.7			11.8	
Approach LOS		C			C			B			B	

Intersection Summary		
HCM Average Control Delay	14.6	HCM Level of Service
HCM Volume to Capacity ratio	0.66	B
Actuated Cycle Length (s)	69.8	Sum of lost time (s)
Intersection Capacity Utilization	63.6%	13.2
Analysis Period (min)	15	ICU Level of Service
		B

c Critical Lane Group



TWO-WAY STOP CONTROL SUMMARY

Analyst: AG  
 Agency/Co.: American  
 Date Performed: 07/15/2013  
 Analysis Time Period: AM Peak  
 Intersection: Nundy Ave & US 41  
 Jurisdiction: FDOT D7  
 Units: U. S. Customary  
 Analysis Year: 2030 Build  
 Project ID: US 41 PD&E Study  
 East/West Street: Nundy Ave  
 North/South Street: US 41  
 Intersection Orientation: NS  
 Study period (hrs): 0.25

Vehicle Volumes and Adjustments

Major Street:	Approach Movement	Northbound			Southbound		
		1 L	2 T	3 R	4 L	5 T	6 R
Volume		14	1476	23	35	806	4
Peak-Hour Factor, PHF		0.95	0.95	0.95	0.95	0.95	0.95
Hourly Flow Rate, HFR		14	1553	24	36	848	4
Percent Heavy Vehicles		5	--	--	5	--	--
Median Type/Storage		Raised curb			/ 1		
RT Channelized?							
Lanes		1	2	0	1	2	0
Configuration		L	T	TR	L	T	TR
Upstream Signal?		No			Yes		

Minor Street:	Approach Movement	Westbound			Eastbound		
		7 L	8 T	9 R	10 L	11 T	12 R
Volume		63	0	95	2	5	11
Peak Hour Factor, PHF		0.95	0.95	0.95	0.95	0.95	0.95
Hourly Flow Rate, HFR		66	0	100	2	5	11
Percent Heavy Vehicles		10	10	10	0	0	0
Percent Grade (%)		0			0		
Flared Approach: Exists?/Storage					/ No /		
Lanes		0	1	1	0	1	0
Configuration		LT		R	LTR		

Delay, Queue Length, and Level of Service

Approach	NB	SB	Westbound			Eastbound		
			7 LT	8 R	9 R	10 L	11 LTR	12
Movement	1	4	7	8	9	10	11	12
Lane Config	L	L	LT	R	R	L	LTR	
v (vph)	14	36	66		100		18	
C(m) (vph)	993	400	87		370		231	
v/c	0.01	0.09	0.76		0.27		0.08	
95% queue length	0.04	0.29	3.83		1.08		0.25	
Control Delay	8.7	14.9	122.7		18.3		21.9	
LOS	A	B	F		C		C	
Approach Delay				59.8			21.9	
Approach LOS				F			C	

HCM Signalized Intersection Capacity Analysis  
40: Alice Ave & US 41

7/23/2013



Movement	EBL	EBT	EBR	WBL	WBT	WBR	NBL	NBT	NBR	SBL	SBT	SBR
Lane Configurations		↕		↙↘	↑	↗↖	↙	↑↑↑	↗	↙↘	↑↑↑	↘
Volume (vph)	18	33	8	393	78	607	14	1957	273	296	1108	21
Ideal Flow (vphpl)	1900	1900	1900	1900	1900	1900	1900	1900	1900	1900	1900	1900
Total Lost time (s)		9.0		9.0	9.0	9.0	6.1	6.1	6.1	6.7	6.1	
Lane Util. Factor		1.00		0.94	1.00	0.88	1.00	0.91	1.00	0.94	0.91	
Fr't		0.98		1.00	1.00	0.85	1.00	1.00	0.85	1.00	1.00	
Flt Protected		0.98		0.95	1.00	1.00	0.95	1.00	1.00	0.95	1.00	
Satd. Flow (prot)		1839		4802	1792	2682	1719	4940	1538	4848	4926	
Flt Permitted		0.87		0.95	1.00	1.00	0.95	1.00	1.00	0.95	1.00	
Satd. Flow (perm)		1618		4802	1792	2682	1719	4940	1538	4848	4926	
Peak-hour factor, PHF	0.95	0.95	0.95	0.95	0.95	0.95	0.95	0.95	0.95	0.95	0.95	0.95
Adj. Flow (vph)	19	35	8	414	82	639	15	2060	287	312	1166	22
RTOR Reduction (vph)	0	0	0	0	0	0	0	0	0	0	0	0
Lane Group Flow (vph)	0	62	0	414	82	639	15	2060	287	312	1188	0
Heavy Vehicles (%)	0%	0%	0%	6%	6%	6%	5%	5%	5%	5%	5%	5%
Turn Type	Perm			Prot		pt+ov	Prot		pt+ov	Prot		
Protected Phases		8		7	4	4 5	1	6	6 7	5	2	
Permitted Phases	8											
Actuated Green, G (s)		16.3		14.7	40.0	61.3	2.2	69.5	90.3	12.3	80.2	
Effective Green, g (s)		16.3		14.7	40.0	61.3	2.2	69.5	90.3	12.3	80.2	
Actuated g/C Ratio		0.11		0.10	0.28	0.43	0.02	0.48	0.63	0.09	0.56	
Clearance Time (s)		9.0		9.0	9.0		6.1	6.1		6.7	6.1	
Vehicle Extension (s)		3.0		3.0	6.0		3.0	8.0		3.0	8.0	
Lane Grp Cap (vph)		184		492	499	1145	26	2391	967	415	2751	
v/s Ratio Prot				c0.09	0.05	c0.24	0.01	c0.42	0.19	c0.06	0.24	
v/s Ratio Perm		0.04										
v/c Ratio		0.34		0.84	0.16	0.56	0.58	0.86	0.30	0.75	0.43	
Uniform Delay, d1		58.7		63.3	39.2	31.0	70.2	32.8	12.2	64.2	18.4	
Progression Factor		1.00		1.00	1.00	1.00	1.00	1.00	1.00	1.00	1.00	
Incremental Delay, d2		4.9		12.3	0.7	2.0	27.4	4.4	0.2	11.9	0.5	
Delay (s)		63.6		75.6	39.9	32.9	97.6	37.2	12.3	76.0	18.9	
Level of Service		E		E	D	C	F	D	B	E	B	
Approach Delay (s)		63.6			49.0			34.5			30.8	
Approach LOS		E			D			C			C	

Intersection Summary

HCM Average Control Delay	37.0	HCM Level of Service	D
HCM Volume to Capacity ratio	0.75		
Actuated Cycle Length (s)	143.6	Sum of lost time (s)	15.1
Intersection Capacity Utilization	85.0%	ICU Level of Service	E
Analysis Period (min)	15		

c Critical Lane Group

HCM Signalized Intersection Capacity Analysis  
 9: Industrial Access Rd & US 41

7/23/2013



Movement	EBL	EBT	EBR	WBL	WBT	WBR	NBL	NBT	NBR	SBL	SBT	SBR
Lane Configurations	↙	↑	↘	↙↘↔	↑	↘	↙	↙↘↔	↘	↙	↙↘↔	↘
Volume (vph)	9	14	20	433	48	295	81	2241	241	24	1208	41
Ideal Flow (vphpl)	1900	1900	1900	1900	1900	1900	1900	1900	1900	1900	1900	1900
Total Lost time (s)	6.3	6.3	6.4	6.3	6.3	6.3	6.4	6.4	6.3	6.4	6.4	6.4
Lane Util. Factor	1.00	1.00	1.00	0.94	1.00	1.00	1.00	0.91	1.00	1.00	0.91	1.00
Fr <sub>t</sub>	1.00	1.00	0.85	1.00	1.00	0.85	1.00	1.00	0.85	1.00	1.00	0.85
Flt Protected	0.95	1.00	1.00	0.95	1.00	1.00	0.95	1.00	1.00	0.95	1.00	1.00
Satd. Flow (prot)	1583	1667	1417	4802	1792	1524	1719	4940	1538	1719	4940	1538
Flt Permitted	0.72	1.00	1.00	0.95	1.00	1.00	0.95	1.00	1.00	0.95	1.00	1.00
Satd. Flow (perm)	1206	1667	1417	4802	1792	1524	1719	4940	1538	1719	4940	1538
Peak-hour factor, PHF	0.95	0.95	0.95	0.95	0.95	0.95	0.95	0.95	0.95	0.95	0.95	0.95
Adj Flow (vph)	9	15	21	456	51	311	85	2359	254	25	1272	43
RTOR Reduction (vph)	0	0	12	0	0	0	0	0	79	0	0	0
Lane Group Flow (vph)	9	15	9	456	51	311	85	2359	175	25	1272	43
Heavy Vehicles (%)	14%	14%	14%	6%	6%	6%	5%	5%	5%	5%	5%	5%
Turn Type	Perm		pm+ov	Prot		Prot	Prot		pm+ov	Prot		Prot
Protected Phases		8	1	7	4	4	1	6	7	5	2	2
Permitted Phases	8		8						6			
Actuated Green, G (s)	5.9	5.9	14.2	19.0	31.2	31.2	8.3	55.7	74.7	2.2	49.6	49.6
Effective Green, g (s)	5.9	5.9	14.2	19.0	31.2	31.2	8.3	55.7	74.7	2.2	49.6	49.6
Actuated g/C Ratio	0.05	0.05	0.13	0.18	0.29	0.29	0.08	0.51	0.69	0.02	0.46	0.46
Clearance Time (s)	6.3	6.3	6.4	6.3	6.3	6.3	6.4	6.4	6.3	6.4	6.4	6.4
Vehicle Extension (s)	6.0	6.0	3.0	3.0	6.0	6.0	3.0	8.0	3.0	3.0	8.0	8.0
Lane Grp Cap (vph)	66	91	186	843	517	439	132	2543	1062	35	2265	705
v/s Ratio Prot		0.01	0.00	0.09	0.03	c0.20	c0.05	c0.48	0.03	0.01	0.26	0.03
v/s Ratio Perm	0.01		0.00						0.09			
v/c Ratio	0.14	0.16	0.05	0.54	0.10	0.71	0.64	0.93	0.17	0.71	0.56	0.06
Uniform Delay, d1	48.7	48.8	41.1	40.6	28.2	34.4	48.5	24.4	5.9	52.7	21.4	16.3
Progression Factor	1.00	1.00	1.00	1.00	1.00	1.00	1.00	1.00	1.00	1.00	1.00	1.00
Incremental Delay, d2	2.7	2.4	0.1	0.7	0.2	7.5	10.3	7.4	0.1	51.0	1.0	0.2
Delay (s)	51.4	51.2	41.2	41.3	28.4	42.0	58.8	31.8	5.9	103.7	22.4	16.5
Level of Service	D	D	D	D	C	D	E	C	A	F	C	B
Approach Delay (s)		46.6			40.8			30.2			23.7	
Approach LOS		D			D			C			C	

Intersection Summary		
HCM Average Control Delay	30.3	HCM Level of Service C
HCM Volume to Capacity ratio	0.87	
Actuated Cycle Length (s)	108.2	Sum of lost time (s) 19.1
Intersection Capacity Utilization	83.2%	ICU Level of Service E
Analysis Period (min)	15	

c Critical Lane Group

HCM Signalized Intersection Capacity Analysis  
 10: Pendola Point Rd & US 41

7/23/2013



Movement	EBL	EBT	EBR	WBL	WBT	WBR	NBL	NBT	NBR	SBL	SBT	SBR
Lane Configurations	↙	↘		↙	↑	↗	↙	↑↑↑	↗	↙↘	↑↑↑	↗
Volume (vph)	57	10	22	108	26	749	17	2205	69	406	1071	75
Ideal Flow (vphpl)	1900	1900	1900	1900	1900	1900	1900	1900	1900	1900	1900	1900
Total Lost time (s)	8.1	8.1		7.1	7.1	7.1	7.5	7.5	7.5	7.5	7.5	7.5
Lane Util. Factor	1.00	1.00		1.00	1.00	0.76	1.00	0.91	1.00	0.94	0.91	1.00
Fr't	1.00	0.90		1.00	1.00	0.85	1.00	1.00	0.85	1.00	1.00	0.85
Flt Protected	0.95	1.00		0.95	1.00	1.00	0.95	1.00	1.00	0.95	1.00	1.00
Satd. Flow (prot)	1157	1094		1641	1727	3347	1719	4940	1538	4848	4940	1538
Flt Permitted	0.74	1.00		0.56	1.00	1.00	0.95	1.00	1.00	0.95	1.00	1.00
Satd. Flow (perm)	901	1094		962	1727	3347	1719	4940	1538	4848	4940	1538
Peak-hour factor, PHF	0.95	0.95	0.95	0.95	0.95	0.95	0.95	0.95	0.95	0.95	0.95	0.95
Adj. Flow (vph)	60	11	23	114	27	788	18	2321	73	427	1127	79
RTOR Reduction (vph)	0	21	0	0	0	60	0	0	19	0	0	29
Lane Group Flow (vph)	60	13	0	114	27	728	18	2321	54	427	1127	50
Heavy Vehicles (%)	56%	56%	56%	10%	10%	10%	5%	5%	5%	5%	5%	5%
Turn Type	pm+pt			pm+pt			pt+ov	Prot		Perm	Prot	Perm
Protected Phases	3	8		7	4	4	5	1	6		5	2
Permitted Phases	8			4					6			2
Actuated Green, G (s)	17.3	13.4		28.5	19.0	42.6	3.5	82.6	82.6	16.5	95.6	95.6
Effective Green, g (s)	17.3	13.4		28.5	19.0	42.6	3.5	82.6	82.6	16.5	95.6	95.6
Actuated g/C Ratio	0.11	0.09		0.19	0.12	0.28	0.02	0.54	0.54	0.11	0.63	0.63
Clearance Time (s)	8.1	8.1		7.1	7.1		7.5	7.5	7.5	7.5	7.5	7.5
Vehicle Extension (s)	3.0	6.0		3.0	6.0		3.0	8.0	8.0	6.0	8.0	8.0
Lane Grp Cap (vph)	109	96		223	216	937	40	2681	835	526	3103	966
v/s Ratio Prot	0.01	0.01		c0.03	0.02	c0.22	0.01	c0.47		c0.09	0.23	
v/s Ratio Perm	0.05			0.06					0.04			0.03
v/c Ratio	0.55	0.14		0.51	0.12	0.78	0.45	0.87	0.06	0.81	0.36	0.05
Uniform Delay, d1	63.3	64.1		54.1	59.2	50.4	73.4	30.0	16.5	66.3	13.6	10.9
Progression Factor	1.00	1.00		1.00	1.00	1.00	1.00	1.00	1.00	1.00	1.00	1.00
Incremental Delay, d2	5.9	1.8		2.0	0.7	5.2	7.9	4.1	0.1	10.9	0.3	0.1
Delay (s)	69.2	65.9		56.1	59.9	55.6	81.3	34.1	16.6	77.2	14.0	11.0
Level of Service	E	E		E	E	E	F	C	B	E	B	B
Approach Delay (s)		68.0			55.8			33.9			30.4	
Approach LOS		E			E			C			C	

Intersection Summary

HCM Average Control Delay	37.4	HCM Level of Service	D
HCM Volume to Capacity ratio	0.84		
Actuated Cycle Length (s)	152.2	Sum of lost time (s)	21.7
Intersection Capacity Utilization	82.3%	ICU Level of Service	E
Analysis Period (min)	15		

c Critical Lane Group

HCM Signalized Intersection Capacity Analysis  
 17: Port Sutton Rd & US 41

7/23/2013



Movement	EBL	EBR	NBL	NBT	SBU	SBT	SBR
Lane Configurations							
Volume (vph)	47	17	32	2759	9	1515	107
Ideal Flow (vphpl)	1900	1900	1900	1900	1900	1900	1900
Total Lost time (s)	7.7	7.0	7.0	6.7	6.4	6.7	7.7
Lane Util. Factor	1.00	1.00	1.00	0.91	1.00	0.91	1.00
Flt	1.00	0.85	1.00	1.00	1.00	1.00	0.85
Flt Protected	0.95	1.00	0.95	1.00	0.95	1.00	1.00
Satd. Flow (prot)	1271	1137	1719	4940	1719	4940	1538
Flt Permitted	0.95	1.00	0.95	1.00	0.95	1.00	1.00
Satd. Flow (perm)	1271	1137	1719	4940	1719	4940	1538
Peak-hour factor, PHF	0.95	0.95	0.95	0.95	0.95	0.95	0.95
Adj. Flow (vph)	49	18	34	2904	9	1595	113
RTOR Reduction (vph)	0	15	0	0	0	0	28
Lane Group Flow (vph)	49	3	34	2904	9	1595	85
Heavy Vehicles (%)	42%	42%	5%	5%	5%	5%	5%
Turn Type		pm+ov	Prot		Prot		pm+ov
Protected Phases	8	1	1	6	5	2	8
Permitted Phases		8					2
Actuated Green, G (s)	12.0	15.5	3.5	67.4	1.0	64.3	76.3
Effective Green, g (s)	12.0	15.5	3.5	67.4	1.0	64.3	76.3
Actuated g/C Ratio	0.12	0.15	0.03	0.67	0.01	0.64	0.75
Clearance Time (s)	7.7	7.0	7.0	6.7	6.4	6.7	7.7
Vehicle Extension (s)	6.0	3.0	3.0	8.0	3.0	8.0	6.0
Lane Grp Cap (vph)	151	174	59	3290	17	3139	1160
v/s Ratio Prot	c0.04	0.00	c0.02	c0.59	0.01	0.32	0.01
v/s Ratio Perm		0.00					0.05
v/c Ratio	0.32	0.02	0.58	0.88	0.53	0.51	0.07
Uniform Delay, d1	40.9	36.4	48.1	13.7	49.9	9.9	3.2
Progression Factor	1.00	1.00	1.00	1.00	1.00	1.00	1.00
Incremental Delay, d2	3.5	0.0	12.9	3.8	26.7	0.6	0.1
Delay (s)	44.4	36.4	61.0	17.5	76.5	10.5	3.3
Level of Service	D	D	E	B	E	B	A
Approach Delay (s)	42.2			18.0		10.4	
Approach LOS	D			B		B	

Intersection Summary			
HCM Average Control Delay	15.6	HCM Level of Service	B
HCM Volume to Capacity ratio	0.82		
Actuated Cycle Length (s)	101.2	Sum of lost time (s)	21.4
Intersection Capacity Utilization	71.1%	ICU Level of Service	C
Analysis Period (min)	15		

c Critical Lane Group

TWO-WAY STOP CONTROL SUMMARY

Analyst: AG  
 Agency/Co.: American  
 Date Performed: 07/15/2013  
 Analysis Time Period: AM Peak  
 Intersection: Hartford St & US 41  
 Jurisdiction: FDOT D7  
 Units: U. S. Customary  
 Analysis Year: 2030 Build  
 Project ID: US 41 PD&E Study  
 East/West Street: Hartford St  
 North/South Street: US 41  
 Intersection Orientation: NS

Study period (hrs): 0.25

		Vehicle Volumes and Adjustments					
Major Street:	Approach Movement	Northbound			Southbound		
		1	2	3	4	5	6
		L	T	R	L	T	R
Volume		12	1923	22	93	1133	30
Peak-Hour Factor, PHF		0.95	0.95	0.95	0.95	0.95	0.95
Hourly Flow Rate, HFR		12	2024	23	97	1192	31
Percent Heavy Vehicles		5	--	--	5	--	--
Median Type/Storage		Raised curb			/ 1		
RT Channelized?							
Lanes		1	2	0	1	2	0
Configuration		L	T	TR	L	T	TR
Upstream Signal?		No			No		

		Westbound			Eastbound		
Minor Street:	Approach Movement	7	8	9	10	11	12
		L	T	R	L	T	R
Volume		20	0	101	4	0	3
Peak Hour Factor, PHF		0.95	0.95	0.95	0.95	0.95	0.95
Hourly Flow Rate, HFR		21	0	106	4	0	3
Percent Heavy Vehicles		27	27	27	0	0	0
Percent Grade (%)		0			0		
Flared Approach: Exists?/Storage					/	No /	
Lanes		0	1	1	0	1	0
Configuration		LT		R	LTR		

		Delay, Queue Length, and Level of Service							
Approach	Movement	NB	SB	Westbound			Eastbound		
		1	4	7	8	9	10	11	12
		L	L	LT		R		LTR	
v (vph)		12	97	21		106		7	
C(m) (vph)		549	260			236		0	
v/c		0.02	0.37			0.45			
95% queue length		0.07	1.65			2.16			
Control Delay		11.7	26.9			32.1			
LOS		B	D			D		F	
Approach Delay									
Approach LOS									

Arterial Level of Service: NB US 41

Cross Street	Arterial Class	Flow Speed	Running Time	Signal Delay	Travel Time (s)	Dist (mi)	Arterial Speed	Arterial LOS
Symmes Rd	II	45	162.3	28.1	190.4	2.03	38.4	A
Palm Ave.	II	40	40.6	16.0	56.6	0.42	26.9	C
Gibsonton Dr	II	40	52.7	39.4	92.1	0.59	22.9	C
Riverview Dr	II	40	93.1	26.7	119.8	1.03	31.1	B
CR 676A (Madison Ave)	II	45	222.0	34.6	256.6	2.77	38.9	A
Port Sutton Rd	II	45	34.3	14.9	49.2	0.36	26.2	C
Total	II		605.0	159.7	764.7	7.20	33.9	B

Arterial Level of Service: SB US 41

Cross Street	Arterial Class	Flow Speed	Running Time	Signal Delay	Travel Time (s)	Dist (mi)	Arterial Speed	Arterial LOS
Port Sutton Rd	II	45	92.6	10.9	103.5	1.16	40.2	A
Pendola Point Rd	II	45	34.3	13.3	47.6	0.36	27.0	C
Industrial Access Rd	II	45	222.0	22.1	244.1	2.77	40.9	A
Alice Ave	II	40	93.1	18.0	111.1	1.03	33.5	B
Palm Ave	II	40	52.7	12.1	64.8	0.59	32.5	B
Symmes Rd	II	40	40.6	11.7	52.3	0.42	29.1	B
Total	II		535.3	88.1	623.4	6.33	36.6	A

## TWO-WAY STOP CONTROL SUMMARY

Analyst: AG  
 Agency/Co.: American  
 Date Performed: 07/15/2013  
 Analysis Time Period: PM Peak  
 Intersection: Kracker Avenue & US 41  
 Jurisdiction: FDOT D7  
 Units: U. S. Customary  
 Analysis Year: 2030 Build  
 Project ID: US 41 PD&E Study  
 East/West Street: Kracker Ave  
 North/South Street: US 41  
 Intersection Orientation: NS

Study period (hrs): 0.25

		Vehicle Volumes and Adjustments						
Major Street:	Approach Movement	Northbound			Southbound			
		1 L	2 T	3 R	4 L	5 T	6 R	
Volume		8	737	11	6	1349	4	
Peak-Hour Factor, PHF		0.95	0.95	0.95	0.95	0.95	0.95	
Hourly Flow Rate, HFR		8	775	11	6	1420	4	
Percent Heavy Vehicles		5	--	--	5	--	--	
Median Type/Storage		Raised curb			/ 1			
RT Channelized?								
Lanes		1	2	0	1	2	0	
Configuration		L	T	TR	L	T	TR	
Upstream Signal?		No			No			
Minor Street:		Westbound			Eastbound			
	Approach Movement	7	8	9	10	11	12	
		L	T	R	L	T	R	
Volume		12	2	12	5	0	5	
Peak Hour Factor, PHF		0.95	0.95	0.95	0.95	0.95	0.95	
Hourly Flow Rate, HFR		12	2	12	5	0	5	
Percent Heavy Vehicles		15	15	15	0	0	0	
Percent Grade (%)		0			0			
Flared Approach: Exists?/Storage					/			
Lanes		0	1	1	0	1	1	
Configuration		LT		R	LT		R	
		Delay, Queue Length, and Level of Service						
Approach Movement	Lane Config	NB	SB	Westbound		Eastbound		
		1 L	4 L	7 LT	8 R	9 R	10 LT	11 R
v (vph)		8	6	14		12	5	5
C(m) (vph)		459	809	168		616	116	436
v/c		0.02	0.01	0.08		0.02	0.04	0.01
95% queue length		0.05	0.02	0.27		0.06	0.13	0.03
Control Delay		13.0	9.5	28.4		11.0	37.4	13.4
LOS		B	A	D		B	E	B
Approach Delay					20.3			
Approach LOS					C			
						25.4		
						D		



TWO-WAY STOP CONTROL SUMMARY

Analyst: AG  
 Agency/Co.: American  
 Date Performed: 07/15/2013  
 Analysis Time Period: PM Peak  
 Intersection: Ohio Street & US 41  
 Jurisdiction: FDOT D7  
 Units: U. S. Customary  
 Analysis Year: 2030 Build  
 Project ID: US 41 PD&E Study  
 East/West Street: Ohio Street  
 North/South Street: US 41  
 Intersection Orientation: NS Study period (hrs): 0.25

Vehicle Volumes and Adjustments

Major Street:	Approach Movement	Northbound			Southbound		
		1 L	2 T	3 R	4 L	5 T	6 R

Volume		742	17		98	1242	
Peak-Hour Factor, PHF		0.95	0.95		0.95	0.95	
Hourly Flow Rate, HFR		781	17		103	1307	
Percent Heavy Vehicles		--	--		5	--	--
Median Type/Storage		Raised curb			/ 1		
RT Channelized?							
Lanes		2	0		1	2	
Configuration		T	TR		L	T	
Upstream Signal?		No			No		

Minor Street:	Approach Movement	Westbound			Eastbound		
		7 L	8 T	9 R	10 L	11 T	12 R

Volume		21		38			
Peak Hour Factor, PHF		0.95		0.95			
Hourly Flow Rate, HFR		22		40			
Percent Heavy Vehicles		0		0			
Percent Grade (%)			0			0	
Flared Approach: Exists?/Storage					/ /		
Lanes		1		1			
Configuration		L		R			

Delay, Queue Length, and Level of Service

Approach Movement	NB	SB	Westbound			Eastbound		
			7 L	8 L	9 R	10 L	11 T	12 R

v (vph)		103	22		40		
C(m) (vph)		801	204		655		
v/c		0.13	0.11		0.06		
95% queue length		0.44	0.36		0.19		
Control Delay		10.2	24.8		10.9		
LOS		B	C		B		
Approach Delay				15.8			
Approach LOS				C			

TWO-WAY STOP CONTROL SUMMARY

Analyst: AG  
 Agency/Co.: American  
 Date Performed: 07/15/2013  
 Analysis Time Period: PM Peak  
 Intersection: Florence St & US 41  
 Jurisdiction: FDOT D7  
 Units: U. S. Customary  
 Analysis Year: 2030 Build  
 Project ID: US 41 PD&E Study  
 East/West Street: Florence Street  
 North/South Street: US 41  
 Intersection Orientation: NS Study period (hrs): 0.25

Vehicle Volumes and Adjustments

Major Street:	Approach Movement	Northbound			Southbound		
		1 L	2 T	3 R	4 L	5 T	6 R

Volume	12	718	1	6	1286	17	
Peak-Hour Factor, PHF	0.95	0.95	0.95	0.95	0.95	0.95	
Hourly Flow Rate, HFR	12	755	1	6	1353	17	
Percent Heavy Vehicles	5	--	--	5	--	--	
Median Type/Storage	Raised curb			/ 1			
RT Channelized?							
Lanes		1	2	0	1	2	0
Configuration		L	T	TR	L	T	TR
Upstream Signal?		No			No		

Minor Street:	Approach Movement	Westbound			Eastbound		
		7 L	8 T	9 R	10 L	11 T	12 R

Volume	4	0	12	20	0	8	
Peak Hour Factor, PHF	0.95	0.95	0.95	0.95	0.95	0.95	
Hourly Flow Rate, HFR	4	0	12	21	0	8	
Percent Heavy Vehicles	0	0	0	0	0	0	
Percent Grade (%)		0			0		
Flared Approach: Exists?/Storage			No	/		No	/
Lanes		0	1	0	0	1	0
Configuration		LTR			LTR		

Delay, Queue Length, and Level of Service

Approach	NB	SB	Westbound			Eastbound		
			7	8	9	10	11	12

Movement	1	4						
Lane Config	L	L		LTR			LTR	
v (vph)	12	6		16			29	
C(m) (vph)	482	831		431			157	
v/c	0.02	0.01		0.04			0.18	
95% queue length	0.08	0.02		0.12			0.65	
Control Delay	12.7	9.4		13.7			33.1	
LOS	B	A		B			D	
Approach Delay				13.7			33.1	
Approach LOS				B			D	

# HCM Signalized Intersection Capacity Analysis

## 35: Symmes Rd & US 41

7/23/2013



Movement	EBL	EBT	EBR	WBL	WBT	WBR	NBL	NBT	NBR	SBL	SBT	SBR
Lane Configurations		↕		↙↘	↖↗	↖↗	↙↘	↑↑↑	↖↗	↙↘	↑↑↑	
Volume (vph)	0	2	0	166	0	189	3	966	116	456	1758	4
Ideal Flow (vphpl)	1900	1900	1900	1900	1900	1900	1900	1900	1900	1900	1900	1900
Total Lost time (s)		7.2		7.2	7.2	7.2	6.2	6.2	7.2	7.0	6.2	
Lane Util. Factor		1.00		0.97	0.95	0.95	1.00	0.91	1.00	0.97	0.91	
Fr <sub>t</sub>		1.00		1.00	0.85	0.85	1.00	1.00	0.85	1.00	1.00	
Fl <sub>t</sub> Protected		1.00		0.95	1.00	1.00	0.95	1.00	1.00	0.95	1.00	
Satd. Flow (prot)		1900		3367	1475	1475	1719	4940	1538	3335	4938	
Fl <sub>t</sub> Permitted		1.00		0.95	1.00	1.00	0.95	1.00	1.00	0.95	1.00	
Satd. Flow (perm)		1900		3367	1475	1475	1719	4940	1538	3335	4938	
Peak-hour factor, PHF	0.95	0.95	0.95	0.95	0.95	0.95	0.95	0.95	0.95	0.95	0.95	0.95
Adj. Flow (vph)	0	2	0	175	0	199	3	1017	122	480	1851	4
RTOR Reduction (vph)	0	0	0	0	0	0	0	0	68	0	0	0
Lane Group Flow (vph)	0	2	0	175	100	99	3	1017	54	480	1855	0
Heavy Vehicles (%)	0%	0%	0%	4%	4%	4%	5%	5%	5%	5%	5%	5%
Turn Type	Perm			Prot		pt+ov	Prot		pm+ov	Prot		
Protected Phases		8		7	4	4.5	1	6	7	5	2	
Permitted Phases	8								6			
Actuated Green, G (s)		1.2		8.4	16.8	36.5	0.7	24.3	32.7	12.5	36.9	
Effective Green, g (s)		1.2		8.4	16.8	36.5	0.7	24.3	32.7	12.5	36.9	
Actuated g/C Ratio		0.02		0.11	0.23	0.49	0.01	0.33	0.44	0.17	0.50	
Clearance Time (s)		7.2		7.2	7.2		6.2	6.2	7.2	7.0	6.2	
Vehicle Extension (s)		3.0		3.0	3.0		3.0	4.0	3.0	3.0	4.0	
Lane Grp Cap (vph)		31		382	335	728	16	1622	680	563	2462	
v/s Ratio Prot		0.00		0.05	c0.07	c0.07	0.00	0.21	0.01	c0.14	c0.38	
v/s Ratio Perm									0.03			
v/c Ratio		0.06		0.46	0.30	0.14	0.19	0.63	0.08	0.85	0.75	
Uniform Delay, d <sub>1</sub>		35.8		30.7	23.7	10.2	36.4	21.0	11.9	29.9	14.9	
Progression Factor		1.00		1.00	1.00	1.00	1.00	1.00	1.00	1.00	1.00	
Incremental Delay, d <sub>2</sub>		0.9		0.9	0.5	0.1	5.6	0.9	0.1	11.9	1.4	
Delay (s)		36.7		31.5	24.2	10.3	42.0	21.9	12.0	41.8	16.3	
Level of Service		D		C	C	B	D	C	B	D	B	
Approach Delay (s)		36.7			24.0			20.9			21.6	
Approach LOS		D			C			C			C	

### Intersection Summary

HCM Average Control Delay	21.6	HCM Level of Service	C
HCM Volume to Capacity ratio	0.68		
Actuated Cycle Length (s)	74.0	Sum of lost time (s)	20.4
Intersection Capacity Utilization	65.1%	ICU Level of Service	C
Analysis Period (min)	15		

c Critical Lane Group

HCM Signalized Intersection Capacity Analysis  
 46: Palm Ave. & US 41

7/23/2013



Movement	EBL	EBT	EBR	WBL	WBT	WBR	NBL	NBT	NBR	SBL	SBT	SEB
Lane Configurations		↕		↙	↘		↙	↑↑↑		↙	↑↑↑	
Volume (vph)	32	3	5	18	1	25	6	1215	13	57	2172	23
Ideal Flow (vphpl)	1900	1900	1900	1900	1900	1900	1900	1900	1900	1900	1900	1900
Total Lost time (s)		6.7		6.7	6.7		6.2	6.2		6.5	6.2	
Lane Util. Factor		1.00		1.00	1.00		1.00	0.91		1.00	0.91	
Frt		0.98		1.00	0.86		1.00	1.00		1.00	1.00	
Flt Protected		0.96		0.95	1.00		0.95	1.00		0.95	1.00	
Satd. Flow (prot)		1728		1805	1626		1719	4932		1719	4932	
Flt Permitted		0.75		0.73	1.00		0.95	1.00		0.95	1.00	
Satd. Flow (perm)		1345		1386	1626		1719	4932		1719	4932	
Peak-hour factor, PHF	0.95	0.95	0.95	0.95	0.95	0.95	0.95	0.95	0.95	0.95	0.95	0.95
Adj. Flow (vph)	34	3	5	19	1	26	6	1279	14	60	2286	24
RTOR Reduction (vph)	0	0	0	0	0	0	0	0	0	0	0	0
Lane Group Flow (vph)	0	42	0	19	27	0	6	1293	0	60	2310	0
Heavy Vehicles (%)	4%	4%	4%	0%	0%	0%	5%	5%	5%	5%	5%	5%
Turn Type	Perm			Perm			Prot			Prot		
Protected Phases		8			4		1	6		5	2	
Permitted Phases	8			4								
Actuated Green, G (s)		8.1		8.1	8.1		5.3	43.0		4.2	42.2	
Effective Green, g (s)		8.1		8.1	8.1		5.3	43.0		4.2	42.2	
Actuated g/C Ratio		0.11		0.11	0.11		0.07	0.58		0.06	0.56	
Clearance Time (s)		6.7		6.7	6.7		6.2	6.2		6.5	6.2	
Vehicle Extension (s)		3.0		3.0	3.0		4.0	4.0		2.5	4.0	
Lane Grp Cap (vph)		146		150	176		122	2839		97	2786	
v/s Ratio Prot					0.02		0.00	0.26		c0.03	c0.47	
v/s Ratio Perm		c0.03		0.01								
v/c Ratio		0.29		0.13	0.15		0.05	0.46		0.62	0.83	
Uniform Delay, d1		30.6		30.1	30.2		32.4	9.1		34.5	13.3	
Progression Factor		1.00		1.00	1.00		1.00	1.00		1.00	1.00	
Incremental Delay, d2		1.1		0.4	0.4		0.2	0.2		9.6	2.3	
Delay (s)		31.7		30.5	30.6		32.6	9.3		44.1	15.6	
Level of Service		C		C	C		C	A		D	B	
Approach Delay (s)		31.7			30.6			9.4			16.3	
Approach LOS		C			C			A			B	

Intersection Summary

HCM Average Control Delay	14.3	HCM Level of Service	B
HCM Volume to Capacity ratio	0.72		
Actuated Cycle Length (s)	74.7	Sum of lost time (s)	19.4
Intersection Capacity Utilization	67.0%	ICU Level of Service	C
Analysis Period (min)	15		

c Critical Lane Group



# HCM Signalized Intersection Capacity Analysis

40: Alice Ave & US 41

7/23/2013



Movement	EBL	EBT	EBR	WBL	WBT	WBR	NBL	NBT	NBR	SBL	SBT	SBR
Lane Configurations		↕		↙↘	↑	↗↖	↙	↑↑↑	↗	↙↘	↑↑↑	
Volume (vph)	11	24	17	451	61	188	13	855	379	596	1946	20
Ideal Flow (vphpl)	1900	1900	1900	1900	1900	1900	1900	1900	1900	1900	1900	1900
Total Lost time (s)		9.0		9.0	9.0	9.0	6.1	6.1	6.1	6.7	6.1	
Lane Util. Factor		1.00		0.94	1.00	0.88	1.00	0.91	1.00	0.94	0.91	
Frt		0.96		1.00	1.00	0.85	1.00	1.00	0.85	1.00	1.00	
Flt Protected		0.99		0.95	1.00	1.00	0.95	1.00	1.00	0.95	1.00	
Satd. Flow (prot)		1695		4848	1810	2707	1719	4940	1538	4848	4932	
Flt Permitted		0.91		0.95	1.00	1.00	0.95	1.00	1.00	0.95	1.00	
Satd. Flow (perm)		1561		4848	1810	2707	1719	4940	1538	4848	4932	
Peak-hour factor, PHF	0.95	0.95	0.95	0.95	0.95	0.95	0.95	0.95	0.95	0.95	0.95	0.95
Adj. Flow (vph)	12	25	18	475	64	198	14	900	399	627	2048	21
RTOR Reduction (vph)	0	0	0	0	0	0	0	0	0	0	0	0
Lane Group Flow (vph)	0	55	0	475	64	198	14	900	399	627	2069	0
Heavy Vehicles (%)	6%	6%	6%	5%	5%	5%	5%	5%	5%	5%	5%	5%
Turn Type	Perm			Prot		pt+ov	Prot		pt+ov	Prot		
Protected Phases		8		7	4	4 5	1	6	6 7	5	2	
Permitted Phases	8											
Actuated Green, G (s)		16.4		15.6	41.0	73.5	1.6	47.4	69.1	23.5	69.9	
Effective Green, g (s)		16.4		15.6	41.0	73.5	1.6	47.4	69.1	23.5	69.9	
Actuated g/C Ratio		0.12		0.12	0.31	0.55	0.01	0.35	0.52	0.18	0.52	
Clearance Time (s)		9.0		9.0	9.0		6.1	6.1		6.7	6.1	
Vehicle Extension (s)		3.0		3.0	6.0		3.0	8.0		3.0	8.0	
Lane Grp Cap (vph)		191		566	555	1488	21	1751	795	852	2579	
v/s Ratio Prot				c0.10	0.04	0.07	0.01	0.18	0.26	c0.13	c0.42	
v/s Ratio Perm		c0.04										
v/c Ratio		0.29		0.84	0.12	0.13	0.67	0.51	0.50	0.74	0.80	
Uniform Delay, d1		53.3		57.8	33.3	14.6	65.8	34.1	21.1	52.2	26.2	
Progression Factor		1.00		1.00	1.00	1.00	1.00	1.00	1.00	1.00	1.00	
Incremental Delay, d2		3.8		10.5	0.4	0.2	58.7	1.1	0.5	5.6	2.7	
Delay (s)		57.1		68.4	33.7	14.8	124.4	35.1	21.6	57.8	29.0	
Level of Service		E		E	C	B	F	D	C	E	C	
Approach Delay (s)		57.1			51.0			32.0			35.7	
Approach LOS		E			D			C			D	

## Intersection Summary

HCM Average Control Delay	37.3	HCM Level of Service	D
HCM Volume to Capacity ratio	0.76		
Actuated Cycle Length (s)	133.7	Sum of lost time (s)	30.8
Intersection Capacity Utilization	74.3%	ICU Level of Service	D
Analysis Period (min)	15		

c Critical Lane Group

HCM Signalized Intersection Capacity Analysis  
 9: Industrial Access Rd & US 41

7/23/2013



Movement	EBL	EBT	EBR	WBL	WBT	WBR	NBL	NBT	NBR	SBL	SBT	SBR
Lane Configurations	↙	↑	↗	↙↗	↑	↗	↙	↑↑↑	↗	↙	↑↑↑	↗
Volume (vph)	29	49	59	516	11	50	20	1002	403	137	2139	15
Ideal Flow (vphpl)	1900	1900	1900	1900	1900	1900	1900	1900	1900	1900	1900	1900
Total Lost time (s)	6.3	6.3	6.4	6.3	6.3	6.3	6.4	6.4	6.3	6.4	6.4	6.4
Lane Util. Factor	1.00	1.00	1.00	0.94	1.00	1.00	1.00	0.91	1.00	1.00	0.91	1.00
Frt	1.00	1.00	0.85	1.00	1.00	0.85	1.00	1.00	0.85	1.00	1.00	0.85
Flt Protected	0.95	1.00	1.00	0.95	1.00	1.00	0.95	1.00	1.00	0.95	1.00	1.00
Satd. Flow (prot)	1787	1881	1599	4990	1863	1583	1719	4940	1538	1719	4940	1538
Flt Permitted	0.75	1.00	1.00	0.95	1.00	1.00	0.95	1.00	1.00	0.95	1.00	1.00
Satd. Flow (perm)	1410	1881	1599	4990	1863	1583	1719	4940	1538	1719	4940	1538
Peak-hour factor, PHF	0.95	0.95	0.95	0.95	0.95	0.95	0.95	0.95	0.95	0.95	0.95	0.95
Adj Flow (vph)	31	52	62	543	12	53	21	1055	424	144	2252	16
RTOR Reduction (vph)	0	0	1	0	0	0	0	0	212	0	0	0
Lane Group Flow (vph)	31	52	61	543	12	53	21	1055	212	144	2252	16
Heavy Vehicles (%)	1%	1%	1%	2%	2%	2%	5%	5%	5%	5%	5%	5%
Turn Type	Perm		pm+ov	Prot		Prot	Prot		pm+ov	Prot		Prot
Protected Phases		8	1	7	4	4	1	6	7	5	2	2
Permitted Phases	8		8						6			
Actuated Green, G (s)	8.8	8.8	11.8	11.1	26.2	26.2	3.0	35.6	46.7	12.4	45.0	45.0
Effective Green, g (s)	8.8	8.8	11.8	11.1	26.2	26.2	3.0	35.6	46.7	12.4	45.0	45.0
Actuated g/C Ratio	0.09	0.09	0.13	0.12	0.28	0.28	0.03	0.38	0.50	0.13	0.48	0.48
Clearance Time (s)	6.3	6.3	6.4	6.3	6.3	6.3	6.4	6.4	6.3	6.4	6.4	6.4
Vehicle Extension (s)	6.0	6.0	3.0	3.0	6.0	6.0	3.0	8.0	3.0	3.0	8.0	8.0
Lane Grp Cap (vph)	133	177	202	594	523	445	55	1885	770	228	2383	742
v/s Ratio Prot		0.03	c0.01	c0.11	0.01	0.03	0.01	0.21	0.03	c0.08	c0.46	0.01
v/s Ratio Perm	0.02		0.03						0.11			
v/c Ratio	0.23	0.29	0.30	0.91	0.02	0.12	0.38	0.56	0.28	0.63	0.95	0.02
Uniform Delay, d1	39.1	39.4	37.0	40.6	24.3	25.0	44.2	22.7	13.5	38.3	23.0	12.6
Progression Factor	1.00	1.00	1.00	1.00	1.00	1.00	1.00	1.00	1.00	1.00	1.00	1.00
Incremental Delay, d2	2.5	2.6	0.8	18.6	0.1	0.3	4.4	1.2	0.2	5.6	9.4	0.1
Delay (s)	41.7	42.0	37.9	59.3	24.3	25.3	48.6	23.9	13.7	43.9	32.4	12.7
Level of Service	D	D	D	E	C	C	D	C	B	D	C	B
Approach Delay (s)		40.1			55.6			21.4			32.9	
Approach LOS		D			E			C			C	

Intersection Summary

HCM Average Control Delay	32.4	HCM Level of Service	C
HCM Volume to Capacity ratio	0.88		
Actuated Cycle Length (s)	93.3	Sum of lost time (s)	25.5
Intersection Capacity Utilization	77.1%	ICU Level of Service	D
Analysis Period (min)	15		

c Critical Lane Group

HCM Signalized Intersection Capacity Analysis  
 10: Pendola Point Rd & US 41

7/23/2013



Movement	EBL	EBT	EBR	WBL	WBT	WBR	NBL	NBT	NBR	SBL	SBT	SBR
Lane Configurations	↖	↗		↖	↗	↖↗	↖	↖↗	↖	↖↗	↖↗	↖
Volume (vph)	118	56	12	156	0	284	2	1208	63	542	2243	7
Ideal Flow (vphpl)	1900	1900	1900	1900	1900	1900	1900	1900	1900	1900	1900	1900
Total Lost time (s)	8.1	8.1		7.1		7.1	7.5	7.5	7.5	7.5	7.5	7.5
Lane Util. Factor	1.00	1.00		1.00		0.76	1.00	0.91	1.00	0.94	0.91	1.00
Fr <sub>t</sub>	1.00	0.97		1.00		0.85	1.00	1.00	0.85	1.00	1.00	0.85
Fl <sub>t</sub> Protected	0.95	1.00		0.95		1.00	0.95	1.00	1.00	0.95	1.00	1.00
Satd. Flow (prot)	1583	1622		1656		3378	1719	4940	1538	4848	4940	1538
Fl <sub>t</sub> Permitted	0.76	1.00		0.57		1.00	0.95	1.00	1.00	0.95	1.00	1.00
Satd. Flow (perm)	1262	1622		996		3378	1719	4940	1538	4848	4940	1538
Peak-hour factor, PHF	0.95	0.95	0.95	0.95	0.95	0.95	0.95	0.95	0.95	0.95	0.95	0.95
Adj. Flow (vph)	124	59	13	164	0	299	2	1272	66	571	2361	7
RTOR Reduction (vph)	0	8	0	0	0	0	0	0	40	0	0	3
Lane Group Flow (vph)	124	64	0	164	0	299	2	1272	26	571	2361	4
Heavy Vehicles (%)	14%	14%	14%	9%	9%	9%	5%	5%	5%	5%	5%	5%
Turn Type	pm+pt			pm+pt		pt+ov	Prot		Perm	Prot		Perm
Protected Phases	3	8		7	4	4 5	1	6		5	2	
Permitted Phases	8			4					6			2
Actuated Green, G (s)	15.9	11.8		24.1		37.6	0.8	41.1	41.1	14.6	54.9	54.9
Effective Green, g (s)	15.9	11.8		24.1		37.6	0.8	41.1	41.1	14.6	54.9	54.9
Actuated g/C Ratio	0.15	0.11		0.23		0.36	0.01	0.39	0.39	0.14	0.52	0.52
Clearance Time (s)	8.1	8.1		7.1			7.5	7.5	7.5	7.5	7.5	7.5
Vehicle Extension (s)	3.0	6.0		3.0			6.0	8.0	8.0	6.0	8.0	8.0
Lane Grp Cap (vph)	202	181		278		1199	13	1917	597	668	2561	797
v/s Ratio Prot	0.02	0.04		c0.05		0.09	0.00	0.26		c0.12	c0.48	
v/s Ratio Perm	0.07			c0.09					0.02			0.00
v/c Ratio	0.61	0.35		0.59		0.25	0.15	0.66	0.04	0.85	0.92	0.01
Uniform Delay, d1	41.7	43.5		35.4		24.2	52.2	26.7	20.2	44.6	23.5	12.3
Progression Factor	1.00	1.00		1.00		1.00	1.00	1.00	1.00	1.00	1.00	1.00
Incremental Delay, d2	5.4	3.3		3.2		0.3	15.0	1.8	0.1	11.8	6.9	0.0
Delay (s)	47.1	46.9		38.6		24.5	67.2	28.5	20.3	56.4	30.5	12.3
Level of Service	D	D		D		C	E	C	C	E	C	B
Approach Delay (s)		47.0			29.5			28.2			35.5	
Approach LOS		D			C			C			D	

Intersection Summary		
HCM Average Control Delay	33.4	HCM Level of Service C
HCM Volume to Capacity ratio	0.91	
Actuated Cycle Length (s)	105.9	Sum of lost time (s) 29.2
Intersection Capacity Utilization	80.4%	ICU Level of Service D
Analysis Period (min)	15	

c Critical Lane Group



HCM Signalized Intersection Capacity Analysis  
 17: Port Sutton Rd & US 41

7/23/2013



Movement	EBL	EBR	NBL	NBT	SBU	SBT	SBR
Lane Configurations	↙	↗	↙	↑↑↑	↑	↑↑↑	↗
Volume (vph)	116	82	0	1552	1	2913	5
Ideal Flow (vphpl)	1900	1900	1900	1900	1900	1900	1900
Total Lost time (s)	7.7	7.0		6.7	6.4	6.7	7.7
Lane Util. Factor	1.00	1.00		0.91	1.00	0.91	1.00
Frt	1.00	0.85		1.00	1.00	1.00	0.85
Flt Protected	0.95	1.00		1.00	0.95	1.00	1.00
Satd. Flow (prot)	1805	1615		4940	1719	4940	1538
Flt Permitted	0.95	1.00		1.00	0.95	1.00	1.00
Satd. Flow (perm)	1805	1615		4940	1719	4940	1538
Peak-hour factor, PHF	0.95	0.95	0.95	0.95	0.95	0.95	0.95
Adj. Flow (vph)	122	86	0	1634	1	3066	5
RTOR Reduction (vph)	0	1	0	0	0	0	1
Lane Group Flow (vph)	122	85	0	1634	1	3066	4
Heavy Vehicles (%)	0%	0%	5%	5%	5%	5%	5%
Turn Type		pm+ov	Prot		Prot		pm+ov
Protected Phases	8	1	1	6	5	2	8
Permitted Phases		8					2
Actuated Green, G (s)	14.3	18.3		78.1	1.0	74.5	88.8
Effective Green, g (s)	14.3	18.3		78.1	1.0	74.5	88.8
Actuated g/C Ratio	0.13	0.16		0.68	0.01	0.65	0.78
Clearance Time (s)	7.7	7.0		6.7	6.4	6.7	7.7
Vehicle Extension (s)	6.0	3.0		8.0	3.0	8.0	6.0
Lane Grp Cap (vph)	226	259		3378	15	3223	1196
v/s Ratio Prot	c0.07	c0.01		c0.33	0.00	c0.62	0.00
v/s Ratio Perm		0.04					0.00
v/c Ratio	0.54	0.33		0.48	0.07	0.95	0.00
Uniform Delay, d1	46.9	42.5		8.5	56.1	18.2	2.8
Progression Factor	1.00	1.00		1.00	1.00	1.00	1.00
Incremental Delay, d2	5.8	0.7		0.5	1.9	8.0	0.0
Delay (s)	52.7	43.3		9.0	58.0	26.2	2.8
Level of Service	D	D		A	E	C	A
Approach Delay (s)	48.8			9.0		26.2	
Approach LOS	D			A		C	

Intersection Summary			
HCM Average Control Delay	21.4	HCM Level of Service	C
HCM Volume to Capacity ratio	0.93		
Actuated Cycle Length (s)	114.2	Sum of lost time (s)	28.1
Intersection Capacity Utilization	74.7%	ICU Level of Service	D
Analysis Period (min)	15		

c Critical Lane Group

## TWO-WAY STOP CONTROL SUMMARY

Analyst: AG  
 Agency/Co.: American  
 Date Performed: 07/15/2013  
 Analysis Time Period: PM Peak  
 Intersection: Hartford St & US 41  
 Jurisdiction: FDOT D7  
 Units: U. S. Customary  
 Analysis Year: 2030 Build  
 Project ID: US 41 PD&E Study  
 East/West Street: Hartford Street  
 North/South Street: US 41  
 Intersection Orientation: NS

Study period (hrs): 0.25

## Vehicle Volumes and Adjustments

Major Street:	Approach Movement	Northbound			Southbound		
		1 L	2 T	3 R	4 L	5 T	6 R

Volume	10	1054	31	58	2144	3
Peak-Hour Factor, PHF	0.95	0.95	0.95	0.95	0.95	0.95
Hourly Flow Rate, HFR	10	1109	32	61	2256	3
Percent Heavy Vehicles	5	--	--	5	--	--
Median Type/Storage	Raised curb			/ 1		
RT Channelized?						
Lanes	1	2	0	1	2	0
Configuration	L	T	TR	L	T	TR
Upstream Signal?	No			No		

Minor Street:	Approach Movement	Westbound			Eastbound		
		7 L	8 T	9 R	10 L	11 T	12 R

Volume	29	0	85	15	0	8
Peak Hour Factor, PHF	0.95	0.95	0.95	0.95	0.95	0.95
Hourly Flow Rate, HFR	30	0	89	15	0	8
Percent Heavy Vehicles	13	13	13	10	10	10
Percent Grade (%)	0				0	
Flared Approach: Exists?/Storage				/		No /
Lanes	0	1	1	0	1	0
Configuration	LT		R	LTR		

## Delay, Queue Length, and Level of Service

Approach Movement	NB 1	SB 4	Westbound			Eastbound		
			7 LT	8 R	9 R	10 L	11 LTR	12

v (vph)	10	61	30	89	23
C(m) (vph)	214	591	77	489	35
v/c	0.05	0.10	0.39	0.18	0.66
95% queue length	0.15	0.34	1.52	0.66	2.28
Control Delay	22.6	11.8	78.9	14.0	221.4
LOS	C	B	F	B	F
Approach Delay	30.4				221.4
Approach LOS	D				F

Arterial Level of Service: NB US 41

Cross Street	Arterial Class	Flow Speed	Running Time	Signal Delay	Travel Time (s)	Dist (mi)	Arterial Speed	Arterial LOS
Symmes Rd	II	45	162.3	22.6	184.9	2.03	39.5	A
Palm Ave.	II	40	40.6	9.9	50.5	0.42	30.1	B
Gibsonston Dr	II	40	52.7	36.5	89.2	0.59	23.6	C
Riverview Dr	II	40	93.1	25.4	118.5	1.03	31.4	B
CR 676A (Madison Ave)	II	45	222.0	30.4	252.4	2.77	39.6	A
Port Sutton Rd	II	45	34.3	7.7	42.0	0.36	30.6	B
Total	II		605.0	132.5	737.5	7.20	35.2	A

Arterial Level of Service: SB US 41

Cross Street	Arterial Class	Flow Speed	Running Time	Signal Delay	Travel Time (s)	Dist (mi)	Arterial Speed	Arterial LOS
Port Sutton Rd	II	45	92.6	28.2	120.8	1.16	34.5	B
Pendola Point Rd	II	45	34.3	23.5	57.8	0.36	22.3	C
Industrial Access Rd	II	45	222.0	30.9	252.9	2.77	39.5	A
Alice Ave	II	40	93.1	27.4	120.5	1.03	30.9	B
Palm Ave.	II	40	52.7	18.2	70.9	0.59	29.7	B
Symmes Rd	II	40	40.6	12.1	52.7	0.42	28.9	B
Total	II		535.3	140.3	675.6	6.33	33.7	B

# Appendix H

## Opening Year 2020 No-Build and Build Level of Service

TWO-WAY STOP CONTROL SUMMARY

Analyst: AG  
 Agency/Co.: American  
 Date Performed: 06/17/2013  
 Analysis Time Period: AM Peak  
 Intersection: Kracker Avenue & US 41  
 Jurisdiction: FDOT D7  
 Units: U. S. Customary  
 Analysis Year: 2020 No Build  
 Project ID: US 41 PD&E Study  
 East/West Street: Kracker Ave  
 North/South Street: US 41  
 Intersection Orientation: NS Study period (hrs): 0.25

Vehicle Volumes and Adjustments

Major Street: Approach Movement	Northbound			Southbound		
	1 L	2 T	3 R	4 L	5 T	6 R
Volume	6	1583	7	1	904	3
Peak-Hour Factor, PHF	0.95	0.95	0.95	0.95	0.95	0.95
Hourly Flow Rate, HFR	6	1666	7	1	951	3
Percent Heavy Vehicles	5	--	--	5	--	--
Median Type/Storage	Raised curb			/ 1		
RT Channelized?	Yes			Yes		
Lanes	1	2	1	1	2	1
Configuration	L	T	R	L	T	R
Upstream Signal?	No			No		

Minor Street: Approach Movement	Westbound			Eastbound		
	7 L	8 T	9 R	10 L	11 T	12 R
Volume	17	0	6	5	0	9
Peak Hour Factor, PHF	0.95	0.95	0.95	0.95	0.95	0.95
Hourly Flow Rate, HFR	17	0	6	5	0	9
Percent Heavy Vehicles	0	0	0	0	0	0
Percent Grade (%)	0			0		
Flared Approach: Exists?/Storage	/			/		
Lanes	0	1	1	0	1	1
Configuration	LT		R	LT		R

Delay, Queue Length, and Level of Service

Approach Movement Lane Config	NB	SB	Westbound			Eastbound		
	1 L	4 L	7 LT	8	9 R	10 LT	11	12 R
v (vph)	6	1	17		6	5		9
C(m) (vph)	700	369	83		372	159		593
v/c	0.01	0.00	0.20		0.02	0.03		0.02
95% queue length	0.03	0.01	0.71		0.05	0.10		0.05
Control Delay	10.2	14.8	59.2		14.8	28.4		11.2
LOS	B	B	F		B	D		B
Approach Delay				47.6			17.3	
Approach LOS				E			C	

TWO-WAY STOP CONTROL SUMMARY

Analyst: AG  
 Agency/Co.: American  
 Date Performed: 06/17/2013  
 Analysis Time Period: AM Peak  
 Intersection: Ohio Street & US 41  
 Jurisdiction: FDOT D7  
 Units: U. S. Customary  
 Analysis Year: 2020 No Build  
 Project ID: US 41 PD&E Study  
 East/West Street: Ohio St  
 North/South Street: US 41  
 Intersection Orientation: NS  
 Study period (hrs): 0.25

Vehicle Volumes and Adjustments

Major Street:	Approach Movement	Northbound			Southbound		
		1 L	2 T	3 R	4 L	5 T	6 R
Volume		1619	15	59	874		
Peak-Hour Factor, PHF		0.95	0.95	0.95	0.95		
Hourly Flow Rate, HFR		1704	15	62	920		
Percent Heavy Vehicles		--	--	5	--	--	
Median Type/Storage		Raised curb			/ 1		
RT Channelized?							
Lanes		2	0		1	2	
Configuration		T	TR		L	T	
Upstream Signal?		No			No		

Minor Street:	Approach Movement	Westbound			Eastbound		
		7 L	8 T	9 R	10 L	11 T	12 R
Volume		29		29			
Peak Hour Factor, PHF		0.95		0.95			
Hourly Flow Rate, HFR		30		30			
Percent Heavy Vehicles		16		16			
Percent Grade (%)			0			0	
Flared Approach: Exists?/Storage				No	/		/
Lanes		0		0			
Configuration			LR				

Delay, Queue Length, and Level of Service

Approach Movement	NB 1	SB 4	Westbound			Eastbound		
			7	8	9	10	11	12
Lane Config		L		LR				
v (vph)		62		60				
C(m) (vph)		351		137				
v/c		0.18		0.44				
95% queue length		0.63		1.94				
Control Delay		17.4		50.3				
LOS		C		F				
Approach Delay				50.3				
Approach LOS				F				

## TWO-WAY STOP CONTROL SUMMARY

Analyst: AG  
 Agency/Co.: American  
 Date Performed: 06/17/2013  
 Analysis Time Period: AM Peak  
 Intersection: Florence St & US 41  
 Jurisdiction: FDOT D7  
 Units: U. S. Customary  
 Analysis Year: 2020 No Build  
 Project ID: US 41 PD&E Study  
 East/West Street: Florence Street  
 North/South Street: US 41  
 Intersection Orientation: NS

Study period (hrs): 0.25

## Vehicle Volumes and Adjustments

Major Street:	Approach Movement	Northbound			Southbound		
		1 L	2 T	3 R	4 L	5 T	6 R

Volume	6	1671	0	3	897	16	
Peak-Hour Factor, PHF	0.95	0.95	0.95	0.95	0.95	0.95	
Hourly Flow Rate, HFR	6	1758	0	3	944	16	
Percent Heavy Vehicles	5	--	--	5	--	--	
Median Type/Storage	Raised curb			/ 1			
RT Channelized?							
Lanes		1	2	0	1	2	0
Configuration		L	T	TR	L	T	TR
Upstream Signal?		No			No		

Minor Street:	Approach Movement	Westbound			Eastbound		
		7 L	8 T	9 R	10 L	11 T	12 R

Volume	6	0	12	12	0	7	
Peak Hour Factor, PHF	0.95	0.95	0.95	0.95	0.95	0.95	
Hourly Flow Rate, HFR	6	0	12	12	0	7	
Percent Heavy Vehicles	0	0	0	0	0	0	
Percent Grade (%)		0			0		
Flared Approach: Exists?/Storage			No	/		No	/
Lanes		0	1	0	0	1	0
Configuration			LTR			LTR	

## Delay, Queue Length, and Level of Service

Approach Movement	NB	SB	Westbound			Eastbound		
	1	4	7	8	9	10	11	12

Lane Config	L	L		LTR			LTR	
v (vph)	6	3		18			19	
C(m) (vph)	694	339		155			208	
v/c	0.01	0.01		0.12			0.09	
95% queue length	0.03	0.03		0.39			0.30	
Control Delay	10.2	15.7		31.3			24.0	
LOS	B	C		D			C	
Approach Delay				31.3			24.0	
Approach LOS				D			C	

HCM Signalized Intersection Capacity Analysis  
 35: Symmes Rd & US 41

7/22/2013



Movement	EBL	EBT	EBR	WBL	WBT	WBR	NBL	NBT	NBR	SBL	SBT	SBR
Lane Configurations		↕		↙	↘			↕	↗	↖	↕	
Volume (vph)	1	0	0	170	0	399	13	1477	159	149	870	0
Ideal Flow (vphpl)	1900	1900	1900	1900	1900	1900	1900	1900	1900	1900	1900	1900
Total Lost time (s)		7.2		7.2	7.2			6.2	6.2	7.0	6.2	
Lane Util. Factor		1.00		1.00	1.00			0.95	1.00	1.00	0.95	
Frt		1.00		1.00	0.85			1.00	0.85	1.00	1.00	
Flt Protected		0.95		0.95	1.00			1.00	1.00	0.95	1.00	
Satd. Flow (prot)		1805		1703	1524			3437	1538	1719	3438	
Flt Permitted		0.24		0.76	1.00			0.94	1.00	0.06	1.00	
Satd. Flow (perm)		448		1357	1524			3236	1538	102	3438	
Peak-hour factor, PHF	0.95	0.95	0.95	0.95	0.95	0.95	0.95	0.95	0.95	0.95	0.95	0.95
Adj. Flow (vph)	1	0	0	179	0	420	14	1555	167	157	916	0
RTOR Reduction (vph)	0	0	0	0	0	0	0	0	62	0	0	0
Lane Group Flow (vph)	0	1	0	179	420	0	0	1569	105	157	916	0
Heavy Vehicles (%)	0%	0%	0%	6%	6%	6%	5%	5%	5%	5%	5%	5%
Turn Type	Perm			Perm			Perm		Perm	pm+pt		
Protected Phases		8			4			6		5	2	
Permitted Phases	8			4			6		6	2		
Actuated Green, G (s)		37.3		37.3	37.3			63.9	63.9	76.9	76.9	
Effective Green, g (s)		37.3		37.3	37.3			63.9	63.9	76.9	76.9	
Actuated g/C Ratio		0.29		0.29	0.29			0.50	0.50	0.60	0.60	
Clearance Time (s)		7.2		7.2	7.2			6.2	6.2	7.0	6.2	
Vehicle Extension (s)		3.0		3.0	3.0			4.0	4.0	3.0	4.0	
Lane Grp Cap (vph)		131		397	445			1621	770	138	2072	
v/s Ratio Prot					c0.28					c0.05	0.27	
v/s Ratio Perm		0.00		0.13				0.48	0.07	c0.63		
v/c Ratio		0.01		0.45	0.94			0.97	0.14	1.14	0.44	
Uniform Delay, d1		32.0		36.8	44.1			30.9	17.1	35.4	13.7	
Progression Factor		1.00		1.00	1.00			1.00	1.00	1.00	1.00	
Incremental Delay, d2		0.0		0.8	28.7			15.3	0.1	118.4	0.2	
Delay (s)		32.0		37.6	72.9			46.2	17.2	153.8	13.9	
Level of Service		C		D	E			D	B	F	B	
Approach Delay (s)		32.0			62.3			43.4			34.4	
Approach LOS		C			E			D			C	

Intersection Summary

HCM Average Control Delay	43.9	HCM Level of Service	D
HCM Volume to Capacity ratio	1.04		
Actuated Cycle Length (s)	127.6	Sum of lost time (s)	14.2
Intersection Capacity Utilization	106.3%	ICU Level of Service	G
Analysis Period (min)	15		

c Critical Lane Group



# HCM Signalized Intersection Capacity Analysis

46: Palm Ave. & US 41

7/22/2013



Movement	EBL	EBT	EBR	WBL	WBT	WBR	NBL	NBT	NBR	SBL	SBT	SBR
Lane Configurations		↕		↙	↘		↙	↕	↘	↙	↘	
Volume (vph)	32	0	15	3	0	19	3	1824	7	30	1029	5
Ideal Flow (vphpl)	1900	1900	1900	1900	1900	1900	1900	1900	1900	1900	1900	1900
Total Lost time (s)		6.7		6.7	6.7		6.2	6.2	6.2	6.5	6.5	
Lane Util. Factor		1.00		1.00	1.00		1.00	0.95	1.00	1.00	0.95	
Fr't		0.96		1.00	0.85		1.00	1.00	0.85	1.00	1.00	
Flt Protected		0.97		0.95	1.00		0.95	1.00	1.00	0.95	1.00	
Satd. Flow (prot)		1758		1805	1615		1719	3438	1538	1719	3436	
Flt Permitted		0.78		0.72	1.00		0.26	1.00	1.00	0.06	1.00	
Satd. Flow (perm)		1425		1376	1615		475	3438	1538	103	3436	
Peak-hour factor, PHF	0.95	0.95	0.95	0.95	0.95	0.95	0.95	0.95	0.95	0.95	0.95	0.95
Adj. Flow (vph)	34	0	16	3	0	20	3	1920	7	32	1083	5
RTOR Reduction (vph)	0	0	0	0	0	0	0	0	2	0	0	0
Lane Group Flow (vph)	0	50	0	3	20	0	3	1920	5	32	1088	0
Heavy Vehicles (%)	0%	0%	0%	0%	0%	0%	5%	5%	5%	5%	5%	5%
Turn Type	Perm			Perm			Perm		Perm	pm+pt		
Protected Phases		4			4			2		1	12	
Permitted Phases	4			4			2		2	12		
Actuated Green, G (s)		9.4		9.4	9.4		81.1	81.1	81.1	88.6	95.1	
Effective Green, g (s)		9.4		9.4	9.4		81.1	81.1	81.1	88.6	95.1	
Actuated g/C Ratio		0.08		0.08	0.08		0.69	0.69	0.69	0.75	0.81	
Clearance Time (s)		6.7		6.7	6.7		6.2	6.2	6.2	6.5		
Vehicle Extension (s)		3.0		3.0	3.0		4.0	4.0	4.0	2.5		
Lane Grp Cap (vph)		114		110	129		328	2375	1062	181	2783	
v/s Ratio Prot					0.01			c0.56		0.01	c0.32	
v/s Ratio Perm		c0.04		0.00			0.01		0.00	0.12		
v/c Ratio		0.44		0.03	0.16		0.01	0.81	0.00	0.18	0.39	
Uniform Delay, d1		51.5		49.8	50.3		5.6	12.7	5.6	11.8	3.1	
Progression Factor		1.00		1.00	1.00		1.00	1.00	1.00	1.00	1.00	
Incremental Delay, d2		2.7		0.1	0.6		0.0	2.2	0.0	0.3	0.1	
Delay (s)		54.2		49.9	50.9		5.7	15.0	5.6	12.1	3.2	
Level of Service		D		D	D		A	B	A	B	A	
Approach Delay (s)		54.2			50.7			14.9			3.4	
Approach LOS		D			D			B			A	

Intersection Summary			
HCM Average Control Delay	11.7	HCM Level of Service	B
HCM Volume to Capacity ratio	0.76		
Actuated Cycle Length (s)	117.4	Sum of lost time (s)	19.4
Intersection Capacity Utilization	70.5%	ICU Level of Service	C
Analysis Period (min)	15		

c Critical Lane Group

TWO-WAY STOP CONTROL SUMMARY

Analyst: AG  
 Agency/Co.: American  
 Date Performed: 06/17/2013  
 Analysis Time Period: AM Peak  
 Intersection: Nundy Ave & US 41  
 Jurisdiction: FDOT D7  
 Units: U. S. Customary  
 Analysis Year: 2020 No Build  
 Project ID: US 41 PD&E Study  
 East/West Street: Nundy Ave  
 North/South Street: US 41  
 Intersection Orientation: NS  
 Study period (hrs): 0.25

Vehicle Volumes and Adjustments

Major Street: Approach Movement	Northbound			Southbound		
	1 L	2 T	3 R	4 L	5 T	6 R

Volume	12	1883	20	29	1007	3
Peak-Hour Factor, PHF	0.95	0.95	0.95	0.95	0.95	0.95
Hourly Flow Rate, HFR	12	1982	21	30	1060	3
Percent Heavy Vehicles	5	--	--	5	--	--
Median Type/Storage	Raised curb			/ 1		
RT Channelized?						
Lanes	1	2	0	1	2	0
Configuration	L	T	TR	L	T	TR
Upstream Signal?	No			Yes		

Minor Street: Approach Movement	Westbound			Eastbound		
	7 L	8 T	9 R	10 L	11 T	12 R

Volume	50	0	77	2	4	9
Peak Hour Factor, PHF	0.95	0.95	0.95	0.95	0.95	0.95
Hourly Flow Rate, HFR	52	0	81	2	4	9
Percent Heavy Vehicles	10	10	10	0	0	0
Percent Grade (%)	0			0		
Flared Approach: Exists?/Storage	No			/ No /		
Lanes	0	1	0	0	1	0
Configuration	LTR			LTR		

Delay, Queue Length, and Level of Service

Approach Movement Lane Config	NB	SB	Westbound			Eastbound		
	1 L	4 L	7	8 LTR	9	10	11 LTR	12

v (vph)	12	30	133			15			
C(m) (vph)	758	271	93			144			
v/c	0.02	0.11	1.43			0.10			
95% queue length	0.05	0.37	9.99			0.34			
Control Delay	9.8	19.9	325.6			32.9			
LOS	A	C	F			D			
Approach Delay	325.6			32.9					
Approach LOS	F			D					

# HCM Signalized Intersection Capacity Analysis

40: Alice Ave & US 41

7/22/2013



Movement	EBL	EBT	EBR	WBL	WBT	WBR	NBL	NBT	NBR	SBL	SBT	SBR
Lane Configurations		↕		↖	↗	↗	↖	↕	↖	↖	↕	↗
Volume (vph)	16	29	7	288	57	444	12	1632	227	233	872	17
Ideal Flow (vphpl)	1900	1900	1900	1900	1900	1900	1900	1900	1900	1900	1900	1900
Total Lost time (s)		9.0		9.0	9.0	6.7	6.1	6.1	6.1	6.7	6.1	
Lane Util. Factor		1.00		1.00	1.00	1.00	1.00	0.95	1.00	1.00	0.95	
Fr't		0.98		1.00	1.00	0.85	1.00	1.00	0.85	1.00	1.00	
Flt Protected		0.98		0.95	1.00	1.00	0.95	1.00	1.00	0.95	1.00	
Satd. Flow (prot)		1839		1703	1792	1524	1719	3438	1538	1719	3428	
Flt Permitted		0.91		0.72	1.00	1.00	0.31	1.00	1.00	0.04	1.00	
Satd. Flow (perm)		1691		1293	1792	1524	553	3438	1538	70	3428	
Peak-hour factor, PHF	0.95	0.95	0.95	0.95	0.95	0.95	0.95	0.95	0.95	0.95	0.95	0.95
Adj. Flow (vph)	17	31	7	303	60	467	13	1718	239	245	918	18
RTOR Reduction (vph)	0	0	0	0	0	0	0	0	39	0	0	0
Lane Group Flow (vph)	0	55	0	303	60	467	13	1718	200	245	936	0
Heavy Vehicles (%)	0%	0%	0%	6%	6%	6%	5%	5%	5%	5%	5%	5%
Turn Type	Perm			Perm		pm+ov	Perm		Perm		pm+pt	
Protected Phases		8			4	5		6		5	2	
Permitted Phases	8			4		4	6		6		2	
Actuated Green, G (s)		43.2		43.2	43.2	61.5	96.7	96.7	96.7	121.7	121.7	
Effective Green, g (s)		43.2		43.2	43.2	61.5	96.7	96.7	96.7	121.7	121.7	
Actuated g/C Ratio		0.24		0.24	0.24	0.34	0.54	0.54	0.54	0.68	0.68	
Clearance Time (s)		9.0		9.0	9.0	6.7	6.1	6.1	6.1	6.7	6.1	
Vehicle Extension (s)		3.0		6.0	6.0	3.0	8.0	8.0	8.0	3.0	8.0	
Lane Grp Cap (vph)		406		310	430	521	297	1847	826	215	2318	
v/s Ratio Prot					0.03	0.09		0.50		c0.12	0.27	
v/s Ratio Perm		0.03		c0.23		0.22	0.02		0.13	c0.65		
v/c Ratio		0.14		0.98	0.14	0.90	0.04	0.93	0.24	1.14	0.40	
Uniform Delay, d1		53.7		67.9	53.8	56.2	19.7	38.5	22.2	66.5	13.0	
Progression Factor		1.00		1.00	1.00	1.00	1.00	1.00	1.00	1.00	1.00	
Incremental Delay, d2		0.7		45.7	0.7	20.7	0.3	9.9	0.7	104.1	0.5	
Delay (s)		54.4		113.6	54.5	76.9	20.0	48.4	22.8	170.5	13.5	
Level of Service		D		F	D	E	C	D	C	F	B	
Approach Delay (s)		54.4			88.7			45.1			46.1	
Approach LOS		D			F			D			D	

## Intersection Summary

HCM Average Control Delay	54.5	HCM Level of Service	D
HCM Volume to Capacity ratio	1.07		
Actuated Cycle Length (s)	180.0	Sum of lost time (s)	15.7
Intersection Capacity Utilization	98.8%	ICU Level of Service	F
Analysis Period (min)	15		

c Critical Lane Group

HCM Signalized Intersection Capacity Analysis  
 9: Industrial Access Rd & US 41

7/22/2013



Movement	EBL	EBT	EBR	WBL	WBT	WBR	NBL	NBT	NBR	SBL	SBT	SBR
Lane Configurations		↖	↗		↖	↗	↖	↗	↖	↗	↖	↗
Volume (vph)	8	12	18	276	31	188	64	1766	190	19	976	33
Ideal Flow (vphpl)	1900	1900	1900	1900	1900	1900	1900	1900	1900	1900	1900	1900
Total Lost time (s)		6.3	6.3		6.3	6.3	6.4	6.4	6.4	6.4	6.4	6.4
Lane Util. Factor		1.00	1.00		1.00	1.00	1.00	0.95	1.00	1.00	0.95	1.00
Fr <sub>t</sub>		1.00	0.85		1.00	0.85	1.00	1.00	0.85	1.00	1.00	0.85
Flt Protected		0.98	1.00		0.96	1.00	0.95	1.00	1.00	0.95	1.00	1.00
Satd. Flow (prot)		1636	1417		1715	1524	1719	3438	1538	1719	3438	1538
Flt Permitted		0.86	1.00		0.73	1.00	0.23	1.00	1.00	0.07	1.00	1.00
Satd. Flow (perm)		1434	1417		1313	1524	418	3438	1538	135	3438	1538
Peak-hour factor, PHF	0.95	0.95	0.95	0.95	0.95	0.95	0.95	0.95	0.95	0.95	0.95	0.95
Adj. Flow (vph)	8	13	19	291	33	198	67	1859	200	20	1027	35
RTOR Reduction (vph)	0	0	14	0	0	11	0	0	81	0	0	14
Lane Group Flow (vph)	0	21	5	0	324	187	67	1859	119	20	1027	21
Heavy Vehicles (%)	14%	14%	14%	6%	6%	6%	5%	5%	5%	5%	5%	5%
Turn Type	Perm		Perm	Perm		Perm	Perm		Perm	Perm		Perm
Protected Phases		4			4			2			2	
Permitted Phases	4		4	4		4	2		2	2		2
Actuated Green, G (s)		23.7	23.7		23.7	23.7	53.6	53.6	53.6	53.6	53.6	53.6
Effective Green, g (s)		23.7	23.7		23.7	23.7	53.6	53.6	53.6	53.6	53.6	53.6
Actuated g/C Ratio		0.26	0.26		0.26	0.26	0.60	0.60	0.60	0.60	0.60	0.60
Clearance Time (s)		6.3	6.3		6.3	6.3	6.4	6.4	6.4	6.4	6.4	6.4
Vehicle Extension (s)		6.0	6.0		6.0	6.0	8.0	8.0	8.0	8.0	8.0	8.0
Lane Grp Cap (vph)		378	373		346	401	249	2048	916	80	2048	916
v/s Ratio Prot								c0.54				0.30
v/s Ratio Perm		0.01	0.00		c0.25	0.12	0.16		0.08	0.15		0.01
v/c Ratio		0.06	0.01		0.94	0.47	0.27	0.91	0.13	0.25	0.50	0.02
Uniform Delay, d1		24.8	24.5		32.4	27.8	8.8	16.0	8.0	8.6	10.5	7.5
Progression Factor		1.00	1.00		1.00	1.00	1.00	1.00	1.00	1.00	1.00	1.00
Incremental Delay, d2		0.2	0.0		33.7	2.4	2.6	7.3	0.3	7.3	0.9	0.0
Delay (s)		25.0	24.5		66.1	30.2	11.4	23.4	8.3	16.0	11.4	7.5
Level of Service		C	C		E	C	B	C	A	B	B	A
Approach Delay (s)		24.8			52.5			21.6			11.3	
Approach LOS		C			D			C			B	

Intersection Summary		
HCM Average Control Delay	23.0	HCM Level of Service C
HCM Volume to Capacity ratio	0.92	
Actuated Cycle Length (s)	90.0	Sum of lost time (s) 12.7
Intersection Capacity Utilization	87.4%	ICU Level of Service E
Analysis Period (min)	15	

c Critical Lane Group

HCM Signalized Intersection Capacity Analysis  
 10: Pendola Point Rd & US 41

7/22/2013



Movement	EBL	EBT	EBR	WBL	WBT	WBR	NBL	NBT	NBR	SBL	SBT	SBR
Lane Configurations	↖	↗			↖	↗↘	↖	↗↘	↗	↖↗	↗↘	↖
Volume (vph)	49	9	19	83	0	576	13	1782	56	327	863	60
Ideal Flow (vphpl)	1900	1900	1900	1900	1900	1900	1900	1900	1900	1900	1900	1900
Total Lost time (s)	8.1	8.1			7.1	7.1	7.5	4.4	4.4	7.5	7.5	8.1
Lane Util. Factor	1.00	1.00			1.00	0.88	1.00	0.95	1.00	0.97	0.95	1.00
Flt Protected	1.00	0.90			1.00	0.85	1.00	1.00	0.85	1.00	1.00	0.85
Flt Permitted	0.95	1.00			0.95	1.00	0.95	1.00	1.00	0.95	1.00	1.00
Satd. Flow (prot)	1157	1092			1641	2584	1719	3438	1538	3335	3438	1538
Satd. Flow (perm)	1157	1092			1275	2584	1719	3438	1538	3335	3438	1538
Peak-hour factor, PHF	0.95	0.95	0.95	0.95	0.95	0.95	0.95	0.95	0.95	0.95	0.95	0.95
Adj. Flow (vph)	52	9	20	87	0	606	14	1876	59	344	908	63
RTOR Reduction (vph)	0	0	0	0	0	0	0	0	10	0	0	18
Lane Group Flow (vph)	52	29	0	0	87	606	14	1876	49	344	908	45
Heavy Vehicles (%)	56%	56%	56%	10%	10%	10%	5%	5%	5%	5%	5%	5%
Turn Type	Prot			Perm		pt+ov	Prot		Perm	Prot		pm+ov
Protected Phases	3	8			4	4.5	1	6		5	2	3
Permitted Phases				4					6			2
Actuated Green, G (s)	15.8	39.5			16.6	41.2	2.3	97.3	97.3	17.5	109.4	125.2
Effective Green, g (s)	15.8	39.5			16.6	41.2	2.3	97.3	97.3	17.5	109.4	125.2
Actuated g/C Ratio	0.09	0.23			0.10	0.24	0.01	0.56	0.56	0.10	0.63	0.72
Clearance Time (s)	8.1	8.1			7.1		7.5	4.4	4.4	7.5	7.5	8.1
Vehicle Extension (s)	6.0	6.0			6.0		6.0	8.0	8.0	6.0	8.0	6.0
Lane Grp Cap (vph)	105	247			121	611	23	1919	859	335	2158	1105
v/s Ratio Prot	c0.04	0.03				c0.23	0.01	c0.55		c0.10	0.26	0.00
v/s Ratio Perm					0.07				0.03			0.03
v/c Ratio	0.50	0.12			0.72	0.99	0.61	0.98	0.06	1.03	0.42	0.04
Uniform Delay, d1	75.5	53.6			76.6	66.4	85.6	37.4	17.6	78.4	16.4	7.1
Progression Factor	1.00	1.00			1.00	1.00	1.00	1.00	1.00	1.00	1.00	1.00
Incremental Delay, d2	10.0	0.6			25.4	34.4	61.4	15.9	0.1	56.2	0.6	0.0
Delay (s)	85.4	54.2			102.0	100.7	146.9	53.3	17.7	134.6	17.0	7.2
Level of Service	F	D			F	F	F	D	B	F	B	A
Approach Delay (s)		74.2			100.9			52.9			47.3	
Approach LOS		E			F			D			D	

Intersection Summary

HCM Average Control Delay	59.8	HCM Level of Service	E
HCM Volume to Capacity ratio	0.93		
Actuated Cycle Length (s)	174.3	Sum of lost time (s)	19.6
Intersection Capacity Utilization	90.7%	ICU Level of Service	E
Analysis Period (min)	15		

c Critical Lane Group

HCM Signalized Intersection Capacity Analysis  
 17: Port Sutton Rd & US 41

7/22/2013



Movement	EBL	EBR	NBL	NBT	SBU	SBT	SBR
Lane Configurations	↙	↗	↙	↕	↕	↕	↗
Volume (vph)	37	14	25	2225	7	1200	85
Ideal Flow (vphpl)	1900	1900	1900	1900	1900	1900	1900
Total Lost time (s)	7.7	7.0	7.0	6.7	6.4	6.7	7.7
Lane Util. Factor	1.00	1.00	1.00	0.95	1.00	0.95	1.00
Frt	1.00	0.85	1.00	1.00	1.00	1.00	0.85
Flt Protected	0.95	1.00	0.95	1.00	0.95	1.00	1.00
Satd. Flow (prot)	1271	1137	1719	3438	1719	3438	1538
Flt Permitted	0.95	1.00	0.18	1.00	0.05	1.00	1.00
Satd. Flow (perm)	1271	1137	318	3438	88	3438	1538
Peak-hour factor, PHF	0.95	0.95	0.95	0.95	0.95	0.95	0.95
Adj Flow (vph)	39	15	26	2342	7	1263	89
RTOR Reduction (vph)	0	13	0	0	0	0	18
Lane Group Flow (vph)	39	2	26	2342	7	1263	71
Heavy Vehicles (%)	42%	42%	5%	5%	5%	5%	5%
Turn Type		pm+ov	pm+pt		pm+pt		pm+ov
Protected Phases	8	1	1	6	5	2	8
Permitted Phases		8	6		2		2
Actuated Green, G (s)	11.8	14.8	87.6	84.6	83.0	82.0	93.8
Effective Green, g (s)	11.8	14.8	87.6	84.6	83.0	82.0	93.8
Actuated g/C Ratio	0.10	0.13	0.74	0.72	0.70	0.69	0.79
Clearance Time (s)	7.7	7.0	7.0	6.7	6.4	6.7	7.7
Vehicle Extension (s)	6.0	3.0	3.0	8.0	3.0	8.0	6.0
Lane Grp Cap (vph)	127	142	271	2461	76	2385	1221
v/s Ratio Prot	c0.03	0.00	c0.00	c0.68	0.00	0.37	0.01
v/s Ratio Perm		0.00	0.07		0.06		0.04
v/c Ratio	0.31	0.01	0.10	0.95	0.09	0.53	0.06
Uniform Delay, d1	49.4	45.3	5.3	15.0	22.7	8.8	2.6
Progression Factor	1.00	1.00	1.00	1.00	1.00	1.00	1.00
Incremental Delay, d2	3.8	0.0	0.2	9.9	0.5	0.8	0.1
Delay (s)	53.3	45.3	5.5	24.9	23.3	9.6	2.7
Level of Service	D	D	A	C	C	A	A
Approach Delay (s)	51.1			24.7		9.2	
Approach LOS	D			C		A	

Intersection Summary

HCM Average Control Delay	19.5	HCM Level of Service	B
HCM Volume to Capacity ratio	0.87		
Actuated Cycle Length (s)	118.2	Sum of lost time (s)	21.4
Intersection Capacity Utilization	79.3%	ICU Level of Service	D
Analysis Period (min)	15		

c Critical Lane Group

## TWO-WAY STOP CONTROL SUMMARY

Analyst: AG  
 Agency/Co.: American  
 Date Performed: 06/17/2013  
 Analysis Time Period: AM Peak  
 Intersection: Hartford St & US 41  
 Jurisdiction: FDOT D7  
 Units: U. S. Customary  
 Analysis Year: 2020 No Build  
 Project ID: US 41 PD&E Study  
 East/West Street: Hartford St  
 North/South Street: US 41  
 Intersection Orientation: NS Study period (hrs): 0.25

## Vehicle Volumes and Adjustments

Major Street:	Approach Movement	Northbound			Southbound		
		1 L	2 T	3 R	4 L	5 T	6 R
Volume		9	1523	18	74	895	24
Peak-Hour Factor, PHF		0.95	0.95	0.95	0.95	0.95	0.95
Hourly Flow Rate, HFR		9	1603	18	77	942	25
Percent Heavy Vehicles		5	--	--	5	--	--
Median Type/Storage		Raised curb			/ 1		
RT Channelized?							
Lanes		1	2	0	1	2	0
Configuration		L	T	TR	L	T	TR
Upstream Signal?		No			No		

Minor Street:	Approach Movement	Westbound			Eastbound		
		7 L	8 T	9 R	10 L	11 T	12 R
Volume		16	0	81	4	0	2
Peak Hour Factor, PHF		0.95	0.95	0.95	0.95	0.95	0.95
Hourly Flow Rate, HFR		16	0	85	4	0	2
Percent Heavy Vehicles		27	27	27	0	0	0
Percent Grade (%)		0			0		
Flared Approach: Exists?/Storage		No			/ No /		
Lanes		0	1	0	0	1	0
Configuration		LTR			LTR		

## Delay, Queue Length, and Level of Service

Approach Movement	NB	SB	Westbound			Eastbound			
	1	4	7	8	9	10	11	12	
Lane Config	L	L		LTR			LTR		
v (vph)	9	77	101			6			
C(m) (vph)	690	384	193			127			
v/c	0.01	0.20	0.52			0.05			
95% queue length	0.04	0.74	2.67			0.15			
Control Delay	10.3	16.7	42.5			34.7			
LOS	B	C	E			D			
Approach Delay				42.5			34.7		
Approach LOS				E			D		

Arterial Level of Service: NB US 41

Cross Street	Arterial Class	Flow Speed	Running Time	Signal Delay	Travel Time (s)	Dist (mi)	Arterial Speed	Arterial LOS
Symmes Rd	I	55	134.1	47.6	181.7	2.03	40.2	B
Palm Ave.	I	42	40.6	16.6	57.2	0.42	26.6	D
Gibsonton Dr	I	50	42.1	48.6	90.7	0.59	23.2	D
Riverview Dr	I	50	74.5	24.2	98.7	1.03	37.7	B
CR 676A (Madison Ave	I	55	181.6	58.6	240.2	2.77	41.6	B
Port Sutton Rd	I	50	32.5	19.3	51.8	0.36	24.8	D
CR 676	I	50	83.3	70.7	154.0	1.16	27.0	C
Total	I		588.7	285.6	874.3	8.36	34.4	B

Arterial Level of Service: SB US 41

Cross Street	Arterial Class	Flow Speed	Running Time	Signal Delay	Travel Time (s)	Dist (mi)	Arterial Speed	Arterial LOS
Causeway Blvd	I	50	20.0	70.3	90.3	0.20	8.0	F
Port Sutton Rd	I	50	83.3	9.8	93.1	1.16	44.7	A
Pendola Point Rd	I	50	32.5	16.5	49.0	0.36	26.3	D
Industrial Access Rd	I	55	181.6	11.6	193.2	2.77	51.7	A
Alice Ave	I	50	74.5	13.6	88.1	1.03	42.3	A
Palm Ave.	I	50	42.1	3.8	45.9	0.59	45.9	A
Symmes Rd	I	50	36.3	14.8	51.1	0.42	29.8	C
Total	I		470.3	140.4	610.7	6.53	38.5	B



TWO-WAY STOP CONTROL SUMMARY

Analyst: AG  
 Agency/Co.: American  
 Date Performed: 06/17/2013  
 Analysis Time Period: PM Peak  
 Intersection: Kracker Avenue & US 41  
 Jurisdiction: FDOT D7  
 Units: U. S. Customary  
 Analysis Year: 2020 No Build  
 Project ID: US 41 PD&E Study  
 East/West Street: Kracker Ave  
 North/South Street: US 41  
 Intersection Orientation: NS  
 Study period (hrs): 0.25

Vehicle Volumes and Adjustments

Major Street: Approach Movement	Northbound			Southbound		
	1 L	2 T	3 R	4 L	5 T	6 R
Volume	6	872	9	5	1626	4
Peak-Hour Factor, PHF	0.95	0.95	0.95	0.95	0.95	0.95
Hourly Flow Rate, HFR	6	917	9	5	1711	4
Percent Heavy Vehicles	5	--	--	5	--	--
Median Type/Storage	Raised curb			/ 1		
RT Channelized?	Yes			Yes		
Lanes	1	2	1	1	2	1
Configuration	L	T	R	L	T	R
Upstream Signal?	No			No		

Minor Street: Approach Movement	Westbound			Eastbound		
	7 L	8 T	9 R	10 L	11 T	12 R
Volume	9	2	9	4	0	4
Peak Hour Factor, PHF	0.95	0.95	0.95	0.95	0.95	0.95
Hourly Flow Rate, HFR	9	2	9	4	0	4
Percent Heavy Vehicles	15	15	15	0	0	0
Percent Grade (%)	0			0		
Flared Approach: Exists?/Storage	/			/		
Lanes	0	1	1	0	1	1
Configuration	LT		R	LT		R

Delay, Queue Length, and Level of Service

Approach Movement Lane Config	NB	SB	Westbound			Eastbound		
	1 L	4 L	7 LT	8	9 R	10 LT	11	12 R
v (vph)	6	5	11		9	4		4
C(m) (vph)	354	721	127		564	78		360
v/c	0.02	0.01	0.09		0.02	0.05		0.01
95% queue length	0.05	0.02	0.28		0.05	0.16		0.03
Control Delay	15.3	10.0+	36.0		11.5	53.6		15.1
LOS	C	B	E		B	F		C
Approach Delay			25.0-			34.4		
Approach LOS			C			D		

## TWO-WAY STOP CONTROL SUMMARY

Analyst: AG  
 Agency/Co.: American  
 Date Performed: 06/17/2013  
 Analysis Time Period: PM Peak  
 Intersection: Ohio Street & US 41  
 Jurisdiction: FDOT D7  
 Units: U. S. Customary  
 Analysis Year: 2020 No Build  
 Project ID: US 41 PD&E Study  
 East/West Street: Ohio St  
 North/South Street: US 41  
 Intersection Orientation: NS

Study period (hrs): 0.25

## Vehicle Volumes and Adjustments

Major Street:	Approach Movement	Northbound			Southbound		
		1 L	2 T	3 R	4 L	5 T	6 R
Volume		895	13		84	1593	
Peak-Hour Factor, PHF		0.95	0.95		0.95	0.95	
Hourly Flow Rate, HFR		942	13		88	1676	
Percent Heavy Vehicles		--	--		5	--	--
Median Type/Storage		Raised curb			/ 1		
RT Channelized?							
Lanes		2	0		1	2	
Configuration		T	TR		L	T	
Upstream Signal?		No				No	

Minor Street:	Approach Movement	Westbound			Eastbound		
		7 L	8 T	9 R	10 L	11 T	12 R
Volume		17		30			
Peak Hour Factor, PHF		0.95		0.95			
Hourly Flow Rate, HFR		17		31			
Percent Heavy Vehicles		0		0			
Percent Grade (%)			0			0	
Flared Approach: Exists?/Storage				No	/		/
Lanes		0		0			
Configuration			LR				

## Delay, Queue Length, and Level of Service

Approach Movement	NB 1	SB 4	Westbound			Eastbound		
			7	8	9	10	11	12
Lane Config		L		LR				
v (vph)		88		48				
C(m) (vph)		697		305				
v/c		0.13		0.16				
95% queue length		0.43		0.55				
Control Delay		10.9		19.0				
LOS		B		C				
Approach Delay				19.0				
Approach LOS				C				

## TWO-WAY STOP CONTROL SUMMARY

Analyst: AG  
 Agency/Co.: American  
 Date Performed: 06/17/2013  
 Analysis Time Period: PM Peak  
 Intersection: Florence St & US 41  
 Jurisdiction: FDOT D7  
 Units: U. S. Customary  
 Analysis Year: 2020 No Build  
 Project ID: US 41 PD&E Study  
 East/West Street: Florence St  
 North/South Street: US 41  
 Intersection Orientation: NS

Study period (hrs): 0.25

## Vehicle Volumes and Adjustments

Major Street:	Approach Movement	Northbound			Southbound		
		1 L	2 T	3 R	4 L	5 T	6 R
Volume		10	922	1	5	1630	14
Peak-Hour Factor, PHF		0.95	0.95	0.95	0.95	0.95	0.95
Hourly Flow Rate, HFR		10	970	1	5	1715	14
Percent Heavy Vehicles		5	--	--	5	--	--
Median Type/Storage		Raised curb			/ 1		
RT Channelized?							
Lanes		1	2	0	1	2	0
Configuration		L	T	TR	L	T	TR
Upstream Signal?		No			No		

Minor Street:	Approach Movement	Westbound			Eastbound		
		7 L	8 T	9 R	10 L	11 T	12 R
Volume		3	0	10	16	0	6
Peak Hour Factor, PHF		0.95	0.95	0.95	0.95	0.95	0.95
Hourly Flow Rate, HFR		3	0	10	16	0	6
Percent Heavy Vehicles		0	0	0	0	0	0
Percent Grade (%)		0			0		
Flared Approach: Exists?/Storage		No			/ No /		
Lanes		0	1	0	0	1	0
Configuration		LTR			LTR		

## Delay, Queue Length, and Level of Service

Approach Movement	NB 1	SB 4	Westbound			Eastbound		
			7	8	9	10	11	12
Lane Config	L	L	LTR			LTR		
v (vph)	10	5	13			22		
C(m) (vph)	348	688	347			97		
v/c	0.03	0.01	0.04			0.23		
95% queue length	0.09	0.02	0.12			0.81		
Control Delay	15.7	10.3	15.8			52.7		
LOS	C	B	C			F		
Approach Delay			15.8			52.7		
Approach LOS			C			F		

HCM Signalized Intersection Capacity Analysis  
 35: Symmes Rd & US 41

7/22/2013



Movement	EBL	EBT	EBR	WBL	WBT	WBR	NBL	NBT	NBR	SBL	SBT	SBR
Lane Configurations		↕		↙	↘			↕	↗	↖	↕	↘
Volume (vph)	0	2	0	117	0	134	2	815	98	377	1454	4
Ideal Flow (vphpl)	1900	1900	1900	1900	1900	1900	1900	1900	1900	1900	1900	1900
Total Lost time (s)		7.2		7.2	7.2			6.2	6.2	7.0	6.2	
Lane Util. Factor		1.00		1.00	1.00			0.95	1.00	1.00	0.95	
Fr't		1.00		1.00	0.85			1.00	0.85	1.00	1.00	
Flt Protected		1.00		0.95	1.00			1.00	1.00	0.95	1.00	
Satd. Flow (prot)		1900		1736	1553			3438	1538	1719	3437	
Flt Permitted		1.00		0.76	1.00			0.95	1.00	0.16	1.00	
Satd. Flow (perm)		1900		1382	1553			3268	1538	296	3437	
Peak-hour factor, PHF	0.95	0.95	0.95	0.95	0.95	0.95	0.95	0.95	0.95	0.95	0.95	0.95
Adj. Flow (vph)	0	2	0	123	0	141	2	858	103	397	1531	4
RTOR Reduction (vph)	0	0	0	0	0	0	0	0	66	0	0	0
Lane Group Flow (vph)	0	2	0	123	141	0	0	860	37	397	1535	0
Heavy Vehicles (%)	0%	0%	0%	4%	4%	4%	5%	5%	5%	5%	5%	5%
Turn Type	Perm			Perm			Perm		Perm		pm+pt	
Protected Phases		8			4			6		5	2	
Permitted Phases	8			4			6		6	2		
Actuated Green, G (s)		12.5		12.5	12.5			26.7	26.7	48.9	48.9	
Effective Green, g (s)		12.5		12.5	12.5			26.7	26.7	48.9	48.9	
Actuated g/C Ratio		0.17		0.17	0.17			0.36	0.36	0.65	0.65	
Clearance Time (s)		7.2		7.2	7.2			6.2	6.2	7.0	6.2	
Vehicle Extension (s)		3.0		3.0	3.0			4.0	4.0	3.0	4.0	
Lane Grp Cap (vph)		318		231	260			1167	549	483	2247	
v/s Ratio Prot		0.00			c0.09					0.17	c0.45	
v/s Ratio Perm				0.09				0.26	0.02	c0.37		
v/c Ratio		0.01		0.53	0.54			0.74	0.07	0.82	0.68	
Uniform Delay, d1		26.0		28.5	28.5			21.0	15.8	14.6	8.1	
Progression Factor		1.00		1.00	1.00			1.00	1.00	1.00	1.00	
Incremental Delay, d2		0.0		2.4	2.3			2.6	0.1	10.8	0.9	
Delay (s)		26.0		30.8	30.8			23.6	15.9	25.4	9.0	
Level of Service		C		C	C			C	B	C	A	
Approach Delay (s)		26.0			30.8			22.8			12.4	
Approach LOS		C			C			C			B	

Intersection Summary

HCM Average Control Delay	17.1	HCM Level of Service	B
HCM Volume to Capacity ratio	0.72		
Actuated Cycle Length (s)	74.8	Sum of lost time (s)	13.4
Intersection Capacity Utilization	92.4%	ICU Level of Service	F
Analysis Period (min)	15		

c Critical Lane Group

HCM Signalized Intersection Capacity Analysis  
46: Palm Ave. & US 41

7/22/2013



Movement	EBL	EBT	EBR	WBL	WBT	WBR	NBL	NBT	NBR	SBL	SBT	SBR
Lane Configurations		↕		↖	↗		↖	↗	↗	↖	↗	↖
Volume (vph)	25	3	4	14	1	20	5	1004	10	49	1847	19
Ideal Flow (vphpl)	1900	1900	1900	1900	1900	1900	1900	1900	1900	1900	1900	1900
Total Lost time (s)		6.7		6.7	6.7		6.2	6.2	6.2	6.5	6.5	
Lane Util. Factor		1.00		1.00	1.00		1.00	0.95	1.00	1.00	0.95	
Fr't		0.98		1.00	0.86		1.00	1.00	0.85	1.00	1.00	
Flt Protected		0.96		0.95	1.00		0.95	1.00	1.00	0.95	1.00	
Satd. Flow (prot)		1729		1805	1628		1719	3438	1538	1719	3433	
Flt Permitted		0.76		0.74	1.00		0.11	1.00	1.00	0.15	1.00	
Satd. Flow (perm)		1360		1398	1628		195	3438	1538	272	3433	
Peak-hour factor, PHF	0.95	0.95	0.95	0.95	0.95	0.95	0.95	0.95	0.95	0.95	0.95	0.95
Adj. Flow (vph)	26	3	4	15	1	21	5	1057	11	52	1944	20
RTOR Reduction (vph)	0	0	0	0	0	0	0	0	6	0	0	0
Lane Group Flow (vph)	0	33	0	15	22	0	5	1057	5	52	1964	0
Heavy Vehicles (%)	4%	4%	4%	0%	0%	0%	5%	5%	5%	5%	5%	5%
Turn Type	Perm			Perm			Perm		Perm		pm+pt	
Protected Phases		4			4			2		1	1	2
Permitted Phases	4			4			2		2	1	2	
Actuated Green, G (s)		7.9		7.9	7.9		41.1	41.1	41.1	68.6	75.1	
Effective Green, g (s)		7.9		7.9	7.9		41.1	41.1	41.1	68.6	75.1	
Actuated g/C Ratio		0.08		0.08	0.08		0.43	0.43	0.43	0.72	0.78	
Clearance Time (s)		6.7		6.7	6.7		6.2	6.2	6.2	6.5		
Vehicle Extension (s)		3.0		3.0	3.0		4.0	4.0	4.0	2.5		
Lane Grp Cap (vph)		112		115	134		84	1473	659	610	2688	
v/s Ratio Prot					0.01			0.31		0.02	c0.57	
v/s Ratio Perm		c0.02		0.01			0.03		0.00	0.04		
v/c Ratio		0.29		0.13	0.16		0.06	0.72	0.01	0.09	0.73	
Uniform Delay, d1		41.4		40.8	40.9		16.1	22.6	15.7	6.0	5.3	
Progression Factor		1.00		1.00	1.00		1.00	1.00	1.00	1.00	1.00	
Incremental Delay, d2		1.5		0.5	0.6		0.4	1.8	0.0	0.0	1.0	
Delay (s)		42.8		41.3	41.5		16.5	24.4	15.7	6.0	6.3	
Level of Service		D		D	D		B	C	B	A	A	
Approach Delay (s)		42.8			41.4			24.3			6.3	
Approach LOS		D			D			C			A	

Intersection Summary

HCM Average Control Delay	13.2	HCM Level of Service	B
HCM Volume to Capacity ratio	0.69		
Actuated Cycle Length (s)	95.9	Sum of lost time (s)	13.2
Intersection Capacity Utilization	71.1%	ICU Level of Service	C
Analysis Period (min)	15		

c Critical Lane Group

## TWO-WAY STOP CONTROL SUMMARY

Analyst: AG  
 Agency/Co.: American  
 Date Performed: 06/17/2013  
 Analysis Time Period: PM Peak  
 Intersection: Nundy Ave & US 41  
 Jurisdiction: FDOT D7  
 Units: U. S. Customary  
 Analysis Year: 2020 No Build  
 Project ID: US 41 PD&E Study  
 East/West Street: Nundy Ave  
 North/South Street: US 41  
 Intersection Orientation: NS

Study period (hrs): 0.25

## Vehicle Volumes and Adjustments

Major Street: Approach Movement	Northbound			Southbound		
	1 L	2 T	3 R	4 L	5 T	6 R
Volume	12	994	58	51	1812	8
Peak-Hour Factor, PHF	0.95	0.95	0.95	0.95	0.95	0.95
Hourly Flow Rate, HFR	12	1046	61	53	1907	8
Percent Heavy Vehicles	5	--	--	5	--	--
Median Type/Storage	Raised curb			/ 1		
RT Channelized?						
Lanes	1	2	0	1	2	0
Configuration	L	T	TR	L	T	TR
Upstream Signal?	No			Yes		

Minor Street: Approach Movement	Westbound			Eastbound		
	7 L	8 T	9 R	10 L	11 T	12 R
Volume	64	3	34	4	0	15
Peak Hour Factor, PHF	0.95	0.95	0.95	0.95	0.95	0.95
Hourly Flow Rate, HFR	67	3	35	4	0	15
Percent Heavy Vehicles	3	3	3	0	0	0
Percent Grade (%)	0			0		
Flared Approach: Exists?/Storage	No			/ No /		
Lanes	0	1	0	0	1	0
Configuration	LTR			LTR		

## Delay, Queue Length, and Level of Service

Approach Movement Lane Config	NB	SB	Westbound			Eastbound			
	1	4	7	8	9	10	11	12	
	L	L		LTR			LTR		
v (vph)	12	53	105			19			
C(m) (vph)	396	609	194			259			
v/c	0.03	0.09	0.54			0.07			
95% queue length	0.09	0.28	2.82			0.24			
Control Delay	14.4	11.5	43.5			20.0			
LOS	B	B	E			C			
Approach Delay				43.5			20.0		
Approach LOS				E			C		

HCM Signalized Intersection Capacity Analysis  
40: Alice Ave & US 41

7/22/2013



Movement	EBL	EBT	EBR	WBL	WBT	WBR	NBL	NBT	NBR	SBL	SBT	SBR
Lane Configurations		↕		↙	↑	↗	↙	↕	↗	↙	↕	↗
Volume (vph)	9	21	14	330	44	138	11	713	316	470	1533	16
Ideal Flow (vphpl)	1900	1900	1900	1900	1900	1900	1900	1900	1900	1900	1900	1900
Total Lost time (s)		9.0		9.0	9.0	6.7	6.1	6.1	6.1	6.7	6.1	
Lane Util. Factor		1.00		1.00	1.00	1.00	1.00	0.95	1.00	1.00	0.95	
Fr't		0.96		1.00	1.00	0.85	1.00	1.00	0.85	1.00	1.00	
Flt Protected		0.99		0.95	1.00	1.00	0.95	1.00	1.00	0.95	1.00	
Satd. Flow (prot)		1697		1719	1810	1538	1719	3438	1538	1719	3433	
Flt Permitted		0.96		0.73	1.00	1.00	0.12	1.00	1.00	0.12	1.00	
Satd. Flow (perm)		1638		1316	1810	1538	220	3438	1538	219	3433	
Peak-hour factor, PHF	0.95	0.95	0.95	0.95	0.95	0.95	0.95	0.95	0.95	0.95	0.95	0.95
Adj. Flow (vph)	9	22	15	347	46	145	12	751	333	495	1614	17
RTOR Reduction (vph)	0	0	0	0	0	0	0	0	180	0	0	0
Lane Group Flow (vph)	0	46	0	347	46	145	12	751	153	495	1631	0
Heavy Vehicles (%)	6%	6%	6%	5%	5%	5%	5%	5%	5%	5%	5%	5%
Turn Type	Perm			Perm		pm+ov	Perm		Perm	pm+pt		
Protected Phases		8			4	5		6		5	2	
Permitted Phases	8			4		4	6		6		2	
Actuated Green, G (s)		43.0		43.0	43.0	70.3	32.9	32.9	32.9	66.9	66.9	
Effective Green, g (s)		43.0		43.0	43.0	70.3	32.9	32.9	32.9	66.9	66.9	
Actuated g/C Ratio		0.34		0.34	0.34	0.56	0.26	0.26	0.26	0.54	0.54	
Clearance Time (s)		9.0		9.0	9.0	6.7	6.1	6.1	6.1	6.7	6.1	
Vehicle Extension (s)		3.0		6.0	6.0	3.0	8.0	8.0	8.0	3.0	8.0	
Lane Grp Cap (vph)		563		453	623	865	58	905	405	445	1837	
v/s Ratio Prot					0.03	0.04		0.22		c0.24	0.48	
v/s Ratio Perm		0.03		c0.26		0.06	0.05		0.10	c0.35		
v/c Ratio		0.08		0.77	0.07	0.17	0.21	0.83	0.38	1.11	0.89	
Uniform Delay, d1		27.7		36.5	27.6	13.2	35.9	43.4	37.7	36.6	25.7	
Progression Factor		1.00		1.00	1.00	1.00	1.00	1.00	1.00	1.00	1.00	
Incremental Delay, d2		0.3		11.7	0.2	0.4	7.9	8.7	2.7	76.9	6.8	
Delay (s)		28.0		48.2	27.8	13.6	43.8	52.1	40.4	113.5	32.6	
Level of Service		C		D	C	B	D	D	D	F	C	
Approach Delay (s)		28.0			37.2			48.5			51.4	
Approach LOS		C			D			D			D	

Intersection Summary			
HCM Average Control Delay	48.3	HCM Level of Service	D
HCM Volume to Capacity ratio	0.95		
Actuated Cycle Length (s)	125.0	Sum of lost time (s)	15.7
Intersection Capacity Utilization	98.0%	ICU Level of Service	F
Analysis Period (min)	15		

c Critical Lane Group

HCM Signalized Intersection Capacity Analysis  
 9: Industrial Access Rd & US 41

7/22/2013



Movement	EBL	EBT	EBR	WBL	WBT	WBR	NBL	NBT	NBR	SBL	SBT	SBR
Lane Configurations		↕	↗		↕	↗	↖	↕	↗	↖	↕	↗
Volume (vph)	25	42	52	329	7	32	16	789	317	111	1728	12
Ideal Flow (vphpl)	1900	1900	1900	1900	1900	1900	1900	1900	1900	1900	1900	1900
Total Lost time (s)		6.3	6.3		6.3	6.3	6.4	6.4	6.4	6.4	6.4	6.4
Lane Util. Factor		1.00	1.00		1.00	1.00	1.00	0.95	1.00	1.00	0.95	1.00
Frt		1.00	0.85		1.00	0.85	1.00	1.00	0.85	1.00	1.00	0.85
Flt Protected		0.98	1.00		0.95	1.00	0.95	1.00	1.00	0.95	1.00	1.00
Satd. Flow (prot)		1847	1599		1776	1583	1719	3438	1538	1719	3438	1538
Flt Permitted		0.77	1.00		0.68	1.00	0.08	1.00	1.00	0.30	1.00	1.00
Satd. Flow (perm)		1449	1599		1265	1583	144	3438	1538	536	3438	1538
Peak-hour factor, PHF	0.95	0.95	0.95	0.95	0.95	0.95	0.95	0.95	0.95	0.95	0.95	0.95
Adj. Flow (vph)	26	44	55	346	7	34	17	831	334	117	1819	13
RTOR Reduction (vph)	0	0	9	0	0	24	0	0	147	0	0	6
Lane Group Flow (vph)	0	70	46	0	353	10	17	831	187	117	1819	7
Heavy Vehicles (%)	1%	1%	1%	2%	2%	2%	5%	5%	5%	5%	5%	5%
Turn Type	Perm		Perm	Perm		Perm	Perm		Perm	Perm		Perm
Protected Phases		4			4			2				2
Permitted Phases	4		4	4		4	2		2	2		2
Actuated Green, G (s)		26.9	26.9		26.9	26.9	50.3	50.3	50.3	50.3	50.3	50.3
Effective Green, g (s)		26.9	26.9		26.9	26.9	50.3	50.3	50.3	50.3	50.3	50.3
Actuated g/C Ratio		0.30	0.30		0.30	0.30	0.56	0.56	0.56	0.56	0.56	0.56
Clearance Time (s)		6.3	6.3		6.3	6.3	6.4	6.4	6.4	6.4	6.4	6.4
Vehicle Extension (s)		6.0	6.0		6.0	6.0	8.0	8.0	8.0	8.0	8.0	8.0
Lane Grp Cap (vph)		434	478		379	474	81	1924	861	300	1924	861
v/s Ratio Prot								0.24			c0.53	
v/s Ratio Perm		0.05	0.03		c0.28	0.01	0.12		0.12	0.22		0.00
v/c Ratio		0.16	0.10		0.93	0.02	0.21	0.43	0.22	0.39	0.95	0.01
Uniform Delay, d1		23.2	22.7		30.6	22.2	9.9	11.5	9.9	11.2	18.5	8.8
Progression Factor		1.00	1.00		1.00	1.00	1.00	1.00	1.00	1.00	1.00	1.00
Incremental Delay, d2		0.5	0.2		30.9	0.1	5.8	0.7	0.6	3.8	11.1	0.0
Delay (s)		23.7	23.0		61.5	22.3	15.7	12.2	10.5	14.9	29.7	8.8
Level of Service		C	C		E	C	B	B	B	B	C	A
Approach Delay (s)		23.4			58.0			11.8			28.6	
Approach LOS		C			E			B			C	

Intersection Summary

HCM Average Control Delay	26.1	HCM Level of Service	C
HCM Volume to Capacity ratio	0.94		
Actuated Cycle Length (s)	89.9	Sum of lost time (s)	12.7
Intersection Capacity Utilization	101.4%	ICU Level of Service	G
Analysis Period (min)	15		

c Critical Lane Group



HCM Signalized Intersection Capacity Analysis  
 10: Pendola Point Rd & US 41

7/22/2013



Movement	EBL	EBT	EBR	WBL	WBT	WBR	NBL	NBT	NBR	SBL	SBT	SBR
Lane Configurations	↙	↘			↖	↗	↙	↘	↖	↗	↖	↗
Volume (vph)	101	48	11	120	0	219	2	977	51	437	1808	5
Ideal Flow (vphpl)	1900	1900	1900	1900	1900	1900	1900	1900	1900	1900	1900	1900
Total Lost time (s)	8.1	8.1			7.1	7.1	7.5	7.5	7.5	7.5	7.5	8.1
Lane Util. Factor	1.00	1.00			1.00	0.88	1.00	0.95	1.00	0.97	0.95	1.00
Fr't	1.00	0.97			1.00	0.85	1.00	1.00	0.85	1.00	1.00	0.85
Flt Protected	0.95	1.00			0.95	1.00	0.95	1.00	1.00	0.95	1.00	1.00
Sat'd. Flow (prot)	1583	1619			1656	2608	1719	3438	1538	3335	3438	1538
Flt Permitted	0.95	1.00			0.72	1.00	0.95	1.00	1.00	0.95	1.00	1.00
Sat'd. Flow (perm)	1583	1619			1248	2608	1719	3438	1538	3335	3438	1538
Peak-hour factor, PHF	0.95	0.95	0.95	0.95	0.95	0.95	0.95	0.95	0.95	0.95	0.95	0.95
Adj. Flow (vph)	106	51	12	126	0	231	2	1028	54	460	1903	5
RTOR Reduction (vph)	0	0	0	0	0	0	0	0	18	0	0	1
Lane Group Flow (vph)	106	63	0	0	126	231	2	1028	36	460	1903	4
Heavy Vehicles (%)	14%	14%	14%	9%	9%	9%	5%	5%	5%	5%	5%	5%
Turn Type	Prot			Perm		pt+ov	Prot		Perm	Prot		pm+ov
Protected Phases	3	8			4	4 5	1	6		5	2	3
Permitted Phases				4					6			2
Actuated Green, G (s)	16.2	45.1			21.8	60.8	1.0	81.6	81.6	31.9	112.5	128.7
Effective Green, g (s)	16.2	45.1			21.8	60.8	1.0	81.6	81.6	31.9	112.5	128.7
Actuated g/C Ratio	0.09	0.25			0.12	0.33	0.01	0.45	0.45	0.18	0.62	0.71
Clearance Time (s)	8.1	8.1			7.1		7.5	7.5	7.5	7.5	7.5	8.1
Vehicle Extension (s)	6.0	6.0			6.0		6.0	8.0	8.0	6.0	8.0	6.0
Lane Grp Cap (vph)	141	402			150	873	9	1544	691	586	2129	1089
v/s Ratio Prot	c0.07	0.04				0.09	0.00	0.30		c0.14	c0.55	0.00
v/s Ratio Perm				c0.10					0.02			0.00
v/c Ratio	0.75	0.16			0.84	0.26	0.22	0.67	0.05	0.78	0.89	0.00
Uniform Delay, d1	80.8	53.4			78.2	44.1	90.0	39.3	28.2	71.6	29.5	7.7
Progression Factor	1.00	1.00			1.00	1.00	1.00	1.00	1.00	1.00	1.00	1.00
Incremental Delay, d2	25.5	0.5			36.0	0.5	32.4	2.3	0.1	8.4	6.3	0.0
Delay (s)	106.3	53.9			114.2	44.6	122.4	41.6	28.4	80.0	35.8	7.8
Level of Service	F	D			F	D	F	D	C	F	D	A
Approach Delay (s)		86.8			69.2			41.1			44.3	
Approach LOS		F			E			D			D	

Intersection Summary

HCM Average Control Delay	47.5	HCM Level of Service	D
HCM Volume to Capacity ratio	0.90		
Actuated Cycle Length (s)	181.7	Sum of lost time (s)	30.2
Intersection Capacity Utilization	85.0%	ICU Level of Service	E
Analysis Period (min)	15		

c Critical Lane Group

HCM Signalized Intersection Capacity Analysis  
17: Port Sutton Rd & US 41

7/22/2013



Movement	EBL	EBR	NEL	NBT	SBU	SBT	SBR
Lane Configurations							
Volume (vph)	93	65	0	1251	1	2307	4
Ideal Flow (vphpl)	1900	1900	1900	1900	1900	1900	1900
Total Lost time (s)	7.7	7.0		6.7	6.4	6.7	7.7
Lane Util. Factor	1.00	1.00		0.95	1.00	0.95	1.00
Fr <sub>t</sub>	1.00	0.85		1.00	1.00	1.00	0.85
Fit Protected	0.95	1.00		1.00	0.95	1.00	1.00
Satd. Flow (prot)	1805	1615		3438	1719	3438	1538
Fit Permitted	0.95	1.00		1.00	0.18	1.00	1.00
Satd. Flow (perm)	1805	1615		3438	319	3438	1538
Peak-hour factor, PHF	0.95	0.95	0.95	0.95	0.95	0.95	0.95
Adj. Flow (vph)	98	68	0	1317	1	2428	4
RTOR Reduction (vph)	0	1	0	0	0	0	1
Lane Group Flow (vph)	98	67	0	1317	1	2428	3
Heavy Vehicles (%)	0%	0%	5%	5%	5%	5%	5%
Turn Type		pm+ov	pm+pt		pm+pt		pm+ov
Protected Phases	8	1	1	6	5	2	8
Permitted Phases		8	6		2		2
Actuated Green, G (s)	14.4	18.4		84.6	82.2	81.1	95.5
Effective Green, g (s)	14.4	18.4		84.6	82.2	81.1	95.5
Actuated g/C Ratio	0.12	0.15		0.70	0.68	0.67	0.79
Clearance Time (s)	7.7	7.0		6.7	6.4	6.7	7.7
Vehicle Extension (s)	6.0	3.0		8.0	3.0	8.0	6.0
Lane Grp Cap (vph)	215	246		2406	230	2306	1215
v/s Ratio Prot	c0.05	c0.01		c0.38	0.00	c0.71	0.00
v/s Ratio Perm		0.03			0.00		0.00
v/c Ratio	0.46	0.27		0.55	0.00	1.05	0.00
Uniform Delay, d1	49.6	45.3		8.8	6.8	19.9	2.7
Progression Factor	1.00	1.00		1.00	1.00	1.00	1.00
Incremental Delay, d2	4.3	0.6		0.9	0.0	34.5	0.0
Delay (s)	53.9	45.9		9.7	6.9	54.4	2.7
Level of Service	D	D		A	A	D	A
Approach Delay (s)	50.6			9.7		54.3	
Approach LOS	D			A		D	

Intersection Summary			
HCM Average Control Delay	39.2	HCM Level of Service	D
HCM Volume to Capacity ratio	1.01		
Actuated Cycle Length (s)	120.9	Sum of lost time (s)	28.1
Intersection Capacity Utilization	81.6%	ICU Level of Service	D
Analysis Period (min)	15		

c Critical Lane Group

## TWO-WAY STOP CONTROL SUMMARY

Analyst: AG  
 Agency/Co.: American  
 Date Performed: 06/17/2013  
 Analysis Time Period: PM Peak  
 Intersection: Hartford St & US 41  
 Jurisdiction: FDOT D7  
 Units: U. S. Customary  
 Analysis Year: 2020 No Build  
 Project ID: US 41 PD&E Study  
 East/West Street: Hartford St  
 North/South Street: US 41  
 Intersection Orientation: NS

Study period (hrs): 0.25

## Vehicle Volumes and Adjustments

Major Street: Approach Movement	Northbound			Southbound		
	1 L	2 T	3 R	4 L	5 T	6 R

Volume	8	835	24	46	1693	2
Peak-Hour Factor, PHF	0.95	0.95	0.95	0.95	0.95	0.95
Hourly Flow Rate, HFR	8	878	25	48	1782	2
Percent Heavy Vehicles	5	--	--	5	--	--
Median Type/Storage	Raised curb			/ 1		
RT Channelized?						
Lanes	1	2	0	1	2	0
Configuration	L	T	TR	L	T	TR
Upstream Signal?	No			No		

Minor Street: Approach Movement	Westbound			Eastbound		
	7 L	8 T	9 R	10 L	11 T	12 R

Volume	24	0	67	11	0	7
Peak Hour Factor, PHF	0.95	0.95	0.95	0.95	0.95	0.95
Hourly Flow Rate, HFR	25	0	70	11	0	7
Percent Heavy Vehicles	13	13	13	10	10	10
Percent Grade (%)	0			0		
Flared Approach: Exists?/Storage	No			/ No /		
Lanes	0	1	0	0	1	0
Configuration	LTR			LTR		

## Delay, Queue Length, and Level of Service

Approach Movement	NB	SB	Westbound			Eastbound		
	1	4	7	8	9	10	11	12

Lane Config	L	L	LTR			LTR			
v (vph)	8	48	95			18			
C(m) (vph)	331	730	295			78			
v/c	0.02	0.07	0.32			0.23			
95% queue length	0.07	0.21	1.35			0.81			
Control Delay	16.1	10.3	22.9			64.5			
LOS	C	B	C			F			
Approach Delay				22.9			64.5		
Approach LOS				C			F		

Arterial Level of Service: NB US 41

Cross Street	Arterial Class	Flow Speed	Running Time	Signal Delay	Travel Time (s)	Dist (mi)	Arterial Speed	Arterial LOS
Symmes Rd	I	55	134.1	25.9	160.0	2.03	45.6	A
Palm Ave.	I	42	40.6	26.2	66.8	0.42	22.8	D
Gibsonton Dr	I	50	42.1	52.5	94.6	0.59	22.3	D
Riverview Dr	I	50	74.5	12.4	86.9	1.03	42.9	A
CR 676A (Madison Ave)	I	55	181.6	44.5	226.1	2.77	44.2	A
Port Sutton Rd	I	50	32.5	8.7	41.2	0.36	31.2	C
CR 676	I	50	83.3	101.2	184.5	1.16	22.6	D
Total	I		588.7	271.4	860.1	8.36	35.0	B

Arterial Level of Service: SB US 41

Cross Street	Arterial Class	Flow Speed	Running Time	Signal Delay	Travel Time (s)	Dist (mi)	Arterial Speed	Arterial LOS
Causeway Blvd	I	50	20.0	174.1	194.1	0.20	3.7	F
Port Sutton Rd	I	50	83.3	57.3	140.6	1.16	29.6	C
Pendola Point Rd	I	50	32.5	31.4	63.9	0.36	20.1	E
Industrial Access Rd	I	55	181.6	30.7	212.3	2.77	47.0	A
Alice Ave	I	50	74.5	33.2	107.7	1.03	34.6	B
Palm Ave.	I	50	42.1	7.7	49.8	0.59	42.3	A
Symmes Rd	I	50	36.3	10.5	46.8	0.42	32.5	C
Total	I		470.3	344.9	815.2	6.53	28.8	C

HCS+: Unsignalized Intersections Release 5.6

TWO-WAY STOP CONTROL SUMMARY

Analyst: AG  
 Agency/Co.: American  
 Date Performed: 07/15/2013  
 Analysis Time Period: AM Peak  
 Intersection: Kracker Avenue & US 41  
 Jurisdiction: FDOT D7  
 Units: U. S. Customary  
 Analysis Year: 2020 Build  
 Project ID: US 41 PD&E Study  
 East/West Street: Kracker Ave  
 North/South Street: US 41  
 Intersection Orientation: NS  
 Study period (hrs): 0.25

Vehicle Volumes and Adjustments

Major Street:	Approach Movement	Northbound			Southbound		
		1 L	2 T	3 R	4 L	5 T	6 R
Volume		6	1055	7	1	603	3
Peak-Hour Factor, PHF		0.95	0.95	0.95	0.95	0.95	0.95
Hourly Flow Rate, HFR		6	1110	7	1	634	3
Percent Heavy Vehicles		5	--	--	5	--	--
Median Type/Storage		Raised curb			/ 1		
RT Channelized?							
Lanes		1	2	0	1	2	0
Configuration		L	T	TR	L	T	TR
Upstream Signal?			No			No	

Minor Street:	Approach Movement	Westbound			Eastbound		
		7 L	8 T	9 R	10 L	11 T	12 R
Volume		17	0	6	5	0	9
Peak Hour Factor, PHF		0.95	0.95	0.95	0.95	0.95	0.95
Hourly Flow Rate, HFR		17	0	6	5	0	9
Percent Heavy Vehicles		0	0	0	0	0	0
Percent Grade (%)			0			0	
Flared Approach: Exists?/Storage					/		
Lanes		0	1	1	0	1	1
Configuration		LT		R	LT		R

Delay, Queue Length, and Level of Service

Approach	NB	SB	Westbound			Eastbound		
			7 LT	8 R	9 R	10 LT	11 R	12 R
Movement	1	4	7	8	9	10	11	12
Lane Config	L	L	LT	R	R	LT	R	R
v (vph)	6	1	17		6	5		9
C(m) (vph)	922	604	180		533	270		727
v/c	0.01	0.00	0.09		0.01	0.02		0.01
95% queue length	0.02	0.00	0.31		0.03	0.06		0.04
Control Delay	8.9	11.0	27.1		11.8	18.6		10.0+
LOS	A	B	D		B	C		B
Approach Delay				23.1			13.1	
Approach LOS				C			B	

TWO-WAY STOP CONTROL SUMMARY

Analyst: AG  
 Agency/Co.: American  
 Date Performed: 07/15/2013  
 Analysis Time Period: AM Peak  
 Intersection: Ohio Street & US 41  
 Jurisdiction: FDOT D7  
 Units: U. S. Customary  
 Analysis Year: 2020 Build  
 Project ID: US 41 PD&E Study  
 East/West Street: Ohio St  
 North/South Street: US 41  
 Intersection Orientation: NS  
 Study period (hrs): 0.25

Vehicle Volumes and Adjustments

Major Street:	Approach Movement	Northbound			Southbound		
		1 L	2 T	3 R	4 L	5 T	6 R

Volume		1079	15		59	583	
Peak-Hour Factor, PHF		0.95	0.95		0.95	0.95	
Hourly Flow Rate, HFR		1135	15		62	613	
Percent Heavy Vehicles		--	--		5	--	--
Median Type/Storage		Raised curb			/	1	
RT Channelized?							
Lanes		2	0		1	2	
Configuration		T	TR		L	T	
Upstream Signal?		No				No	

Minor Street:	Approach Movement	Westbound			Eastbound		
		7 L	8 T	9 R	10 L	11 T	12 R

Volume		29		29			
Peak Hour Factor, PHF		0.95		0.95			
Hourly Flow Rate, HFR		30		30			
Percent Heavy Vehicles		16		16			
Percent Grade (%)			0			0	
Flared Approach: Exists?/Storage					/		/
Lanes		1		1			
Configuration		L		R			

Delay, Queue Length, and Level of Service

Approach	NB	SB	Westbound			Eastbound		
			7	8	9	10	11	12

Movement	1	4	7	8	9	10	11	12
Lane Config		L	L		R			
v (vph)		62	30		30			
C(m) (vph)		586	179		478			
v/c		0.11	0.17		0.06			
95% queue length		0.35	0.59		0.20			
Control Delay		11.9	29.1		13.0			
LOS		B	D		B			
Approach Delay				21.1				
Approach LOS				C				

TWO-WAY STOP CONTROL SUMMARY

Analyst: AG  
 Agency/Co.: American  
 Date Performed: 07/15/2013  
 Analysis Time Period: AM Peak  
 Intersection: Florence St & US 41  
 Jurisdiction: FDOT D7  
 Units: U. S. Customary  
 Analysis Year: 2020 Build  
 Project ID: US 41 PD&E Study  
 East/West Street: Florence St  
 North/South Street: US 41  
 Intersection Orientation: NS Study period (hrs): 0.25

Vehicle Volumes and Adjustments

Major Street: Approach Movement	Northbound			Southbound		
	1 L	2 T	3 R	4 L	5 T	6 R

Volume	6	1114	0	3	598	16
Peak-Hour Factor, PHF	0.95	0.95	0.95	0.95	0.95	0.95
Hourly Flow Rate, HFR	6	1172	0	3	629	16
Percent Heavy Vehicles	5	--	--	5	--	--
Median Type/Storage	Raised curb			/ 1		
RT Channelized?						
Lanes	1	2	0	1	2	0
Configuration	L	T	TR	L	T	TR
Upstream Signal?		No			No	

Minor Street: Approach Movement	Westbound			Eastbound		
	7 L	8 T	9 R	10 L	11 T	12 R

Volume	6	0	12	12	0	7
Peak Hour Factor, PHF	0.95	0.95	0.95	0.95	0.95	0.95
Hourly Flow Rate, HFR	6	0	12	12	0	7
Percent Heavy Vehicles	0	0	0	0	0	0
Percent Grade (%)		0			0	
Flared Approach: Exists?/Storage			No	/		No /
Lanes	0	1	0	0	1	0
Configuration		LTR			LTR	

Delay, Queue Length, and Level of Service

Approach Movement	NB	SB	Westbound			Eastbound		
	1	4	7	8	9	10	11	12

Lane Config	L	L	LTR			LTR		
v (vph)	6	3	18			19		
C(m) (vph)	916	575	303			338		
v/c	0.01	0.01	0.06			0.06		
95% queue length	0.02	0.02	0.19			0.18		
Control Delay	9.0	11.3	17.6			16.3		
LOS	A	B	C			C		
Approach Delay			17.6			16.3		
Approach LOS			C			C		

HCM Signalized Intersection Capacity Analysis  
 35: Symmes Rd & US 41

7/22/2013



Movement	EBL	EBT	EBR	WBL	WBT	WBR	NBL	NBT	NBR	SBL	SBT	SBR
Lane Configurations		↕		↕	↕	↕	↕	↑↑↑	↕	↕	↑↑↑	
Volume (vph)	1	0	0	170	0	399	13	1477	159	149	870	0
Ideal Flow (vphpl)	1900	1900	1900	1900	1900	1900	1900	1900	1900	1900	1900	1900
Total Lost time (s)		7.2		7.2	7.2	7.2	6.2	6.2	7.2	7.0	6.2	
Lane Util. Factor		1.00		0.97	0.95	0.95	1.00	0.91	1.00	0.97	0.91	
Frts		1.00		1.00	0.85	0.85	1.00	1.00	0.85	1.00	1.00	
Flt Protected		0.95		0.95	1.00	1.00	0.95	1.00	1.00	0.95	1.00	
Satd. Flow (prot)		1805		3303	1447	1447	1719	4940	1538	3335	4940	
Flt Permitted		1.00		0.95	1.00	1.00	0.95	1.00	1.00	0.95	1.00	
Satd. Flow (perm)		1900		3303	1447	1447	1719	4940	1538	3335	4940	
Peak-hour factor, PHF	0.95	0.95	0.95	0.95	0.95	0.95	0.95	0.95	0.95	0.95	0.95	0.95
Adj. Flow (vph)	1	0	0	179	0	420	14	1555	167	157	916	0
RTOR Reduction (vph)	0	0	0	0	0	0	0	0	75	0	0	0
Lane Group Flow (vph)	0	1	0	179	210	210	14	1555	92	157	916	0
Heavy Vehicles (%)	0%	0%	0%	6%	6%	6%	5%	5%	5%	5%	5%	5%
Turn Type	Perm			Prot		pt+ov	Prot		pm+ov		Prot	
Protected Phases		8		7	4	4.5	1	6	7	5	2	
Permitted Phases	8							6				
Actuated Green, G (s)		1.3		11.3	19.8	32.0	0.7	30.0	41.3	5.0	35.1	
Effective Green, g (s)		1.3		11.3	19.8	32.0	0.7	30.0	41.3	5.0	35.1	
Actuated g/C Ratio		0.02		0.15	0.26	0.43	0.01	0.40	0.55	0.07	0.47	
Clearance Time (s)		7.2		7.2	7.2		6.2	6.2	7.2	7.0	6.2	
Vehicle Extension (s)		3.0		3.0	3.0		3.0	4.0	3.0	3.0	4.0	
Lane Grp Cap (vph)		33		496	381	616	16	1971	845	222	2306	
v/s Ratio Prot				0.05	c0.15	c0.15	0.01	c0.31	0.02	c0.05	c0.19	
v/s Ratio Perm		0.00							0.04			
v/c Ratio		0.03		0.36	0.55	0.34	0.88	0.79	0.11	0.71	0.40	
Uniform Delay, d1		36.3		28.7	23.9	14.5	37.2	19.8	8.1	34.4	13.1	
Progression Factor		1.00		1.00	1.00	1.00	1.00	1.00	1.00	1.00	1.00	
Incremental Delay, d2		0.4		0.5	1.7	0.3	161.3	2.3	0.1	9.8	0.2	
Delay (s)		36.7		29.2	25.6	14.8	198.5	22.1	8.2	44.2	13.3	
Level of Service		D		C	C	B	F	C	A	D	B	
Approach Delay (s)		36.7			22.9			22.2			17.8	
Approach LOS		D			C			C			B	

Intersection Summary

HCM Average Control Delay	20.9	HCM Level of Service	C
HCM Volume to Capacity ratio	0.81		
Actuated Cycle Length (s)	75.2	Sum of lost time (s)	26.6
Intersection Capacity Utilization	68.0%	ICU Level of Service	C
Analysis Period (min)	15		

c Critical Lane Group



HCM Signalized Intersection Capacity Analysis  
46: Palm Ave. & US 41

7/22/2013



Movement	EBL	EBT	EBR	WBL	WBT	WBR	NBL	NBT	NBR	SBL	SBT	SBR
Lane Configurations		↕		↙	↘		↙	↕		↘	↕	
Volume (vph)	32	0	15	3	0	19	3	1824	7	30	1029	5
Ideal Flow (vphpl)	1900	1900	1900	1900	1900	1900	1900	1900	1900	1900	1900	1900
Total Lost time (s)		6.7		6.7	6.7		6.2	6.2		6.5	6.2	
Lane Util. Factor		1.00		1.00	1.00		1.00	0.91		1.00	0.91	
Flt		0.96		1.00	0.85		1.00	1.00		1.00	1.00	
Flt Protected		0.97		0.95	1.00		0.95	1.00		0.95	1.00	
Satd. Flow (prot)		1758		1805	1615		1719	4937		1719	4937	
Flt Permitted		0.78		0.72	1.00		0.95	1.00		0.95	1.00	
Satd. Flow (perm)		1425		1376	1615		1719	4937		1719	4937	
Peak-hour factor, PHF	0.95	0.95	0.95	0.95	0.95	0.95	0.95	0.95	0.95	0.95	0.95	0.95
Adj. Flow (vph)	34	0	16	3	0	20	3	1920	7	32	1083	5
RTOR Reduction (vph)	0	0	0	0	0	0	0	0	0	0	0	0
Lane Group Flow (vph)	0	50	0	3	20	0	3	1927	0	32	1088	0
Heavy Vehicles (%)	0%	0%	0%	0%	0%	0%	5%	5%	5%	5%	5%	5%
Turn Type	Perm			Perm			Prot			Prot		
Protected Phases	8			4			1 6			5 2		
Permitted Phases	8			4								
Actuated Green, G (s)	7.9			7.9 7.9			5.4 29.3			1.7 25.9		
Effective Green, g (s)	7.9			7.9 7.9			5.4 29.3			1.7 25.9		
Actuated g/C Ratio	0.14			0.14 0.14			0.09 0.50			0.03 0.44		
Clearance Time (s)	6.7			6.7 6.7			6.2 6.2			6.5 6.2		
Vehicle Extension (s)	3.0			3.0 3.0			4.0 4.0			2.5 4.0		
Lane Grp Cap (vph)	193			186 219			159 2481			50 2193		
v/s Ratio Prot				0.01			0.00 c0.39			c0.02 0.22		
v/s Ratio Perm	c0.04			0.00								
v/c Ratio	0.26			0.02 0.09			0.02 0.78			0.64 0.50		
Uniform Delay, d1	22.6			21.8 22.1			24.0 11.8			28.0 11.5		
Progression Factor	1.00			1.00 1.00			1.00 1.00			1.00 1.00		
Incremental Delay, d2	0.7			0.0 0.2			0.1 1.7			22.1 0.2		
Delay (s)	23.3			21.9 22.2			24.1 13.5			50.1 11.8		
Level of Service	C			C C			C B			D B		
Approach Delay (s)	23.3			22.2			13.5			12.9		
Approach LOS	C			C			B			B		

Intersection Summary			
HCM Average Control Delay	13.5	HCM Level of Service	B
HCM Volume to Capacity ratio	0.67		
Actuated Cycle Length (s)	58.3	Sum of lost time (s)	19.4
Intersection Capacity Utilization	55.5%	ICU Level of Service	B
Analysis Period (min)	15		

c Critical Lane Group

## TWO-WAY STOP CONTROL SUMMARY

Analyst: AG  
 Agency/Co.: American  
 Date Performed: 07/15/2013  
 Analysis Time Period: AM Peak  
 Intersection: Nundy Ave & US 41  
 Jurisdiction: FDOT D7  
 Units: U. S. Customary  
 Analysis Year: 2020 Build  
 Project ID: US 41 PD&E Study  
 East/West Street: Nundy Ave  
 North/South Street: US 41  
 Intersection Orientation: NS Study period (hrs): 0.25

## Vehicle Volumes and Adjustments

Major Street:	Approach Movement	Northbound			Southbound		
		1 L	2 T	3 R	4 L	5 T	6 R
Volume		12	1255	20	29	671	3
Peak-Hour Factor, PHF		0.95	0.95	0.95	0.95	0.95	0.95
Hourly Flow Rate, HFR		12	1321	21	30	706	3
Percent Heavy Vehicles		5	--	--	5	--	--
Median Type/Storage		Raised curb			/ 1		
RT Channelized?							
Lanes		1	2	0	1	2	0
Configuration		L	T	TR	L	T	TR
Upstream Signal?		No			Yes		

Minor Street:	Approach Movement	Westbound			Eastbound		
		7 L	8 T	9 R	10 L	11 T	12 R
Volume		50	0	77	2	4	9
Peak Hour Factor, PHF		0.95	0.95	0.95	0.95	0.95	0.95
Hourly Flow Rate, HFR		52	0	81	2	4	9
Percent Heavy Vehicles		10	10	10	0	0	0
Percent Grade (%)		0			0		
Flared Approach: Exists?/Storage		/			No /		
Lanes		0	1	1	0	1	0
Configuration		LT		R	LTR		

## Delay, Queue Length, and Level of Service

Approach	NB	SB	Westbound			Eastbound		
			7	8	9	10	11	12
Movement	1	4	7	8	9	10	11	12
Lane Config	L	L	LT		R		LTR	
v (vph)	12	30	52		81		15	
C(m) (vph)	993	494	128		434		308	
v/c	0.01	0.06	0.41		0.19		0.05	
95% queue length	0.04	0.19	1.74		0.68		0.15	
Control Delay	8.7	12.8	51.2		15.2		17.3	
LOS	A	B	F		C		C	
Approach Delay				29.2			17.3	
Approach LOS				D			C	

HCM Signalized Intersection Capacity Analysis  
 40: Alice Ave & US 41

7/22/2013



Movement	EBL	EBT	EBR	WBL	WBT	WBR	NBL	NBT	NBR	SBL	SBT	SBR		
Lane Configurations		↕		↙↘	↑	↗↖	↘	↙↘	↗	↙↘	↙↘	↙↘		
Volume (vph)	16	29	7	288	57	444	12	1632	227	233	872	17		
Ideal Flow (vphpl)	1900	1900	1900	1900	1900	1900	1900	1900	1900	1900	1900	1900		
Total Lost time (s)		9.0		9.0	9.0	9.0	6.1	6.1	6.1	6.7	6.1			
Lane Util. Factor		1.00		0.94	1.00	0.88	1.00	0.91	1.00	0.94	0.91			
Frt		0.98		1.00	1.00	0.85	1.00	1.00	0.85	1.00	1.00			
Flt Protected		0.98		0.95	1.00	1.00	0.95	1.00	1.00	0.95	1.00			
Satd. Flow (prot)		1839		4802	1792	2682	1719	4940	1538	4848	4926			
Flt Permitted		0.87		0.95	1.00	1.00	0.95	1.00	1.00	0.95	1.00			
Satd. Flow (perm)		1632		4802	1792	2682	1719	4940	1538	4848	4926			
Peak-hour factor, PHF	0.95	0.95	0.95	0.95	0.95	0.95	0.95	0.95	0.95	0.95	0.95	0.95		
Adj. Flow (vph)	17	31	7	303	60	467	13	1718	239	245	918	18		
RTOR Reduction (vph)	0	0	0	0	0	0	0	0	0	0	0	0		
Lane Group Flow (vph)	0	55	0	303	60	467	13	1718	239	245	936	0		
Heavy Vehicles (%)	0%	0%	0%	6%	6%	6%	5%	5%	5%	5%	5%	5%		
Turn Type	Perm			Prot			pt+ov		Prot		pt+ov			
Protected Phases	8			7			4 4.5		1 6		6.7 5 2			
Permitted Phases	8													
Actuated Green, G (s)	16.9			13.1			39.0		60.3		2.4 70.6		89.8 12.3 81.1	
Effective Green, g (s)	16.9			13.1			39.0		60.3		2.4 70.6		89.8 12.3 81.1	
Actuated g/C Ratio	0.12			0.09			0.27		0.42		0.02 0.49		0.62 0.09 0.56	
Clearance Time (s)	9.0			9.0			9.0		6.1		6.1		6.7 6.1	
Vehicle Extension (s)	3.0			3.0			6.0		3.0		8.0		3.0 8.0	
Lane Grp Cap (vph)	192			438			486		1125		29 2427		961 415 2780	
v/s Ratio Prot				c0.06			0.03		c0.17		0.01 c0.35		0.16 c0.05 0.19	
v/s Ratio Perm	0.03													
v/c Ratio	0.29			0.69			0.12		0.42		0.45 0.71		0.25 0.59 0.34	
Uniform Delay, d1	57.9			63.3			39.5		29.3		70.0 28.5		12.0 63.3 16.8	
Progression Factor	1.00			1.00			1.00		1.00		1.00		1.00 1.00 1.00	
Incremental Delay, d2	3.7			4.7			0.5		1.1		10.6 1.8		0.1 6.1 0.3	
Delay (s)	61.6			68.0			40.0		30.4		80.6 30.3		12.1 69.3 17.2	
Level of Service	E			E			D		C		F		C B E B	
Approach Delay (s)	61.6						44.8				28.4		28.0	
Approach LOS	E						D				C		C	

Intersection Summary			
HCM Average Control Delay	32.1	HCM Level of Service	C
HCM Volume to Capacity ratio	0.63		
Actuated Cycle Length (s)	143.7	Sum of lost time (s)	21.8
Intersection Capacity Utilization	73.0%	ICU Level of Service	C
Analysis Period (min)	15		

c Critical Lane Group

HCM Signalized Intersection Capacity Analysis  
 9: Industrial Access Rd & US 41

7/22/2013



Movement	EBL	EBT	EBR	WBL	WBT	WBR	NBL	NBT	NBR	SBL	SBT	SBR
Lane Configurations	↙	↑	↗	↙↗	↑	↗	↙	↑↑↑	↗	↙	↑↑↑	↗
Volume (vph)	8	12	18	276	31	188	64	1766	190	19	976	33
Ideal Flow (vphpl)	1900	1900	1900	1900	1900	1900	1900	1900	1900	1900	1900	1900
Total Lost time (s)	6.3	6.3	6.4	6.3	6.3	6.3	6.4	6.4	6.3	6.4	6.4	6.4
Lane Util. Factor	1.00	1.00	1.00	0.94	1.00	1.00	1.00	0.91	1.00	1.00	0.91	1.00
Flt Protected	1.00	1.00	0.85	1.00	1.00	0.85	1.00	1.00	0.85	1.00	1.00	0.85
Flt Permitted	0.95	1.00	1.00	0.95	1.00	1.00	0.95	1.00	1.00	0.95	1.00	1.00
Satd. Flow (prot)	1583	1667	1417	4802	1792	1524	1719	4940	1538	1719	4940	1538
Satd. Flow (perm)	1667	1667	1417	4802	1792	1524	1719	4940	1538	1719	4940	1538
Peak-hour factor, PHF	0.95	0.95	0.95	0.95	0.95	0.95	0.95	0.95	0.95	0.95	0.95	0.95
Adj. Flow (vph)	8	13	19	291	33	198	67	1859	200	20	1027	35
RTOR Reduction (vph)	0	0	17	0	0	0	0	0	73	0	0	0
Lane Group Flow (vph)	8	13	2	291	33	198	67	1859	127	20	1027	35
Heavy Vehicles (%)	14%	14%	14%	6%	6%	6%	5%	5%	5%	5%	5%	5%
Turn Type	Perm		pm+ov	Prot		Prot	Prot		pm+ov	Prot		Prot
Protected Phases		8	1	7	4	4	1	6	7	5	2	2
Permitted Phases	8		8						6			
Actuated Green, G (s)	4.0	4.0	10.5	12.0	22.3	22.3	6.5	42.0	54.0	1.4	36.9	36.9
Effective Green, g (s)	4.0	4.0	10.5	12.0	22.3	22.3	6.5	42.0	54.0	1.4	36.9	36.9
Actuated g/C Ratio	0.05	0.05	0.12	0.14	0.26	0.26	0.08	0.50	0.64	0.02	0.44	0.44
Clearance Time (s)	6.3	6.3	6.4	6.3	6.3	6.3	6.4	6.4	6.3	6.4	6.4	6.4
Vehicle Extension (s)	6.0	6.0	3.0	3.0	6.0	6.0	3.0	8.0	3.0	3.0	8.0	8.0
Lane Grp Cap (vph)	79	79	175	680	471	401	132	2447	979	28	2150	669
v/s Ratio Prot		0.01	0.00	0.06	0.02	c0.13	c0.04	c0.38	0.02	0.01	0.21	0.02
v/s Ratio Perm	0.00		0.00						0.06			
v/c Ratio	0.10	0.16	0.01	0.43	0.07	0.49	0.51	0.76	0.13	0.71	0.48	0.05
Uniform Delay, d1	38.7	38.8	32.6	33.3	23.5	26.5	37.6	17.3	6.1	41.5	17.1	13.8
Progression Factor	1.00	1.00	1.00	1.00	1.00	1.00	1.00	1.00	1.00	1.00	1.00	1.00
Incremental Delay, d2	1.6	2.8	0.0	0.4	0.2	2.7	3.1	2.3	0.1	60.5	0.8	0.1
Delay (s)	40.3	41.6	32.6	33.7	23.6	29.2	40.7	19.6	6.2	102.0	17.8	14.0
Level of Service	D	D	C	C	C	C	D	B	A	F	B	B
Approach Delay (s)		37.1			31.3			19.0			19.3	
Approach LOS		D			C			B			B	

**Intersection Summary**

HCM Average Control Delay	21.0	HCM Level of Service	C
HCM Volume to Capacity ratio	0.69		
Actuated Cycle Length (s)	84.8	Sum of lost time (s)	19.1
Intersection Capacity Utilization	67.4%	ICU Level of Service	C
Analysis Period (min)	15		

c Critical Lane Group

HCM Signalized Intersection Capacity Analysis  
 10: Pendola Point Rd & US 41

7/22/2013



Movement	EBL	EBT	EBR	WBL	WBT	WBR	NBL	NBT	NBR	SBL	SBT	SBR
Lane Configurations	↙	↘		↙	↑	↗↘	↙	↑↑↑	↗	↗↘	↑↑↑	↗
Volume (vph)	49	9	19	83	20	576	13	1782	56	327	863	60
Ideal Flow (vphpl)	1900	1900	1900	1900	1900	1900	1900	1900	1900	1900	1900	1900
Total Lost time (s)	8.1	8.1		7.1	7.1	7.1	7.5	7.5	7.5	7.5	7.5	7.5
Lane Util. Factor	1.00	1.00		1.00	1.00	0.76	1.00	0.91	1.00	0.94	0.91	1.00
Frt	1.00	0.90		1.00	1.00	0.85	1.00	1.00	0.85	1.00	1.00	0.85
Flt Protected	0.95	1.00		0.95	1.00	1.00	0.95	1.00	1.00	0.95	1.00	1.00
Satd. Flow (prot)	1157	1092		1641	1727	3347	1719	4940	1538	4848	4940	1538
Flt Permitted	0.74	1.00		0.43	1.00	1.00	0.95	1.00	1.00	0.95	1.00	1.00
Satd. Flow (perm)	906	1092		741	1727	3347	1719	4940	1538	4848	4940	1538
Peak-hour factor, PHF	0.95	0.95	0.95	0.95	0.95	0.95	0.95	0.95	0.95	0.95	0.95	0.95
Adj. Flow (vph)	52	9	20	87	21	606	14	1876	59	344	908	63
RTOR Reduction (vph)	0	18	0	0	0	128	0	0	30	0	0	33
Lane Group Flow (vph)	52	11	0	87	21	478	14	1876	29	344	908	30
Heavy Vehicles (%)	56%	56%	56%	10%	10%	10%	5%	5%	5%	5%	5%	5%
Turn Type	pm+pt			pm+pt		pt+ov	Prot		Perm	Prot		Perm
Protected Phases	3	8		7	4	4 5	1	6		5	2	
Permitted Phases	8			4					6			2
Actuated Green, G (s)	11.0	8.7		27.0	16.7	30.5	0.8	39.6	39.6	6.7	45.5	45.5
Effective Green, g (s)	11.0	8.7		27.0	16.7	30.5	0.8	39.6	39.6	6.7	45.5	45.5
Actuated g/C Ratio	0.12	0.09		0.28	0.17	0.32	0.01	0.41	0.41	0.07	0.48	0.48
Clearance Time (s)	8.1	8.1		7.1	7.1		7.5	7.5	7.5	7.5	7.5	7.5
Vehicle Extension (s)	3.0	6.0		3.0	6.0		3.0	8.0	8.0	6.0	8.0	8.0
Lane Grp Cap (vph)	110	99		307	302	1069	14	2048	638	340	2354	733
v/s Ratio Prot	0.01	0.01		c0.03	0.01	c0.14	0.01	c0.38		c0.07	c0.18	
v/s Ratio Perm	0.04			0.05					0.02			0.02
v/c Ratio	0.47	0.11		0.28	0.07	0.45	1.00	0.92	0.05	1.01	0.39	0.04
Uniform Delay, d1	39.2	39.8		26.2	32.9	25.8	47.4	26.4	16.7	44.4	16.0	13.3
Progression Factor	1.00	1.00		1.00	1.00	1.00	1.00	1.00	1.00	1.00	1.00	1.00
Incremental Delay, d2	3.2	1.4		0.5	0.3	0.8	240.5	7.9	0.1	51.8	0.5	0.1
Delay (s)	42.4	41.2		26.7	33.2	26.6	287.9	34.3	16.8	96.2	16.5	13.5
Level of Service	D	D		C	C	C	F	C	B	F	B	B
Approach Delay (s)		42.0			26.8			35.6			37.2	
Approach LOS		D			C			D			D	

Intersection Summary

HCM Average Control Delay	34.7	HCM Level of Service	C
HCM Volume to Capacity ratio	0.94		
Actuated Cycle Length (s)	95.5	Sum of lost time (s)	36.7
Intersection Capacity Utilization	70.3%	ICU Level of Service	C
Analysis Period (min)	15		

c Critical Lane Group

HCM Signalized Intersection Capacity Analysis  
 17: Port Sutton Rd & US 41

7/22/2013



Movement	EBL	EBR	NBL	NBT	SBU	SBT	SBR
Lane Configurations	↙	↘	↙	↑↑↑	↑	↑↑↑	↘
Volume (vph)	37	14	25	2225	7	1200	85
Ideal Flow (vphpl)	1900	1900	1900	1900	1900	1900	1900
Total Lost time (s)	7.7	7.0	7.0	6.7	6.4	6.7	7.7
Lane Util. Factor	1.00	1.00	1.00	0.91	1.00	0.91	1.00
Fr't	1.00	0.85	1.00	1.00	1.00	1.00	0.85
Flt Protected	0.95	1.00	0.95	1.00	0.95	1.00	1.00
Satd. Flow (prot)	1271	1137	1719	4940	1719	4940	1538
Flt Permitted	0.95	1.00	0.95	1.00	0.95	1.00	1.00
Satd. Flow (perm)	1271	1137	1719	4940	1719	4940	1538
Peak-hour factor, PHF	0.95	0.95	0.95	0.95	0.95	0.95	0.95
Adj. Flow (vph)	39	15	26	2342	7	1263	89
RTOR Reduction (vph)	0	13	0	0	0	0	27
Lane Group Flow (vph)	39	2	26	2342	7	1263	62
Heavy Vehicles (%)	42%	42%	5%	5%	5%	5%	5%
Turn Type		pm+ov	Prot		Prot		pm+ov
Protected Phases	8	1	1	6	5	2	8
Permitted Phases		8					2
Actuated Green, G (s)	8.7	11.6	2.9	49.5	0.9	46.9	55.6
Effective Green, g (s)	8.7	11.6	2.9	49.5	0.9	46.9	55.6
Actuated g/C Ratio	0.11	0.15	0.04	0.62	0.01	0.59	0.70
Clearance Time (s)	7.7	7.0	7.0	6.7	6.4	6.7	7.7
Vehicle Extension (s)	6.0	3.0	3.0	8.0	3.0	8.0	6.0
Lane Grp Cap (vph)	138	165	62	3060	19	2900	1070
v/s Ratio Prot	c0.03	0.00	c0.02	c0.47	0.00	0.26	0.01
v/s Ratio Perm		0.00					0.03
v/c Ratio	0.28	0.01	0.42	0.77	0.37	0.44	0.06
Uniform Delay, d1	32.7	29.2	37.7	11.0	39.2	9.2	3.9
Progression Factor	1.00	1.00	1.00	1.00	1.00	1.00	1.00
Incremental Delay, d2	3.2	0.0	4.5	1.9	11.7	0.5	0.1
Delay (s)	35.9	29.3	42.2	12.9	50.9	9.6	3.9
Level of Service	D	C	D	B	D	A	A
Approach Delay (s)	34.1			13.2		9.5	
Approach LOS	C			B		A	

**Intersection Summary**

HCM Average Control Delay	12.2	HCM Level of Service	B
HCM Volume to Capacity ratio	0.71		
Actuated Cycle Length (s)	79.9	Sum of lost time (s)	21.4
Intersection Capacity Utilization	60.8%	ICU Level of Service	B
Analysis Period (min)	15		

c Critical Lane Group

TWO-WAY STOP CONTROL SUMMARY

Analyst: AG  
 Agency/Co.: American  
 Date Performed: 07/15/2013  
 Analysis Time Period: AM Peak  
 Intersection: Hartford St & US 41  
 Jurisdiction: FDOT D7  
 Units: U. S. Customary  
 Analysis Year: 2020 Build  
 Project ID: US 41 PD&E Study  
 East/West Street: Hartford St  
 North/South Street: US 41  
 Intersection Orientation: NS Study period (hrs): 0.25

Vehicle Volumes and Adjustments

Major Street: Approach Movement	Northbound			Southbound		
	1 L	2 T	3 R	4 L	5 T	6 R
Volume	9	1523	18	74	895	24
Peak-Hour Factor, PHF	0.95	0.95	0.95	0.95	0.95	0.95
Hourly Flow Rate, HFR	9	1603	18	77	942	25
Percent Heavy Vehicles	5	--	--	5	--	--
Median Type/Storage	Raised curb			/ 1		
RT Channelized?						
Lanes Configuration	1 L	2 T	0 TR	1 L	2 T	0 TR
Upstream Signal?	No			No		

Minor Street: Approach Movement	Westbound			Eastbound		
	7 L	8 T	9 R	10 L	11 T	12 R
Volume	16	0	81	4	0	2
Peak Hour Factor, PHF	0.95	0.95	0.95	0.95	0.95	0.95
Hourly Flow Rate, HFR	16	0	85	4	0	2
Percent Heavy Vehicles	27	27	27	0	0	0
Percent Grade (%)	0			0		
Flared Approach: Exists?/Storage				/ No /		
Lanes Configuration	0 LT	1 R	1	0	1 LTR	0

Delay, Queue Length, and Level of Service

Approach Movement Lane Config	NB	SB	Westbound			Eastbound		
	1 L	4 L	7 LT	8	9 R	10	11 LTR	12
v (vph)	9	77	16		85		6	
C(m) (vph)	690	384	62		322		127	
v/c	0.01	0.20	0.26		0.26		0.05	
95% queue length	0.04	0.74	0.90		1.04		0.15	
Control Delay	10.3	16.7	82.2		20.1		34.7	
LOS	B	C	F		C		D	
Approach Delay				30.0				34.7
Approach LOS				D				D

Arterial Level of Service: NB US 41

Cross Street	Arterial Class	Flow Speed	Running Time	Signal Delay	Travel Time (s)	Dist (mi)	Arterial Speed	Arterial LOS
Symmes Rd	II	45	162.3	22.8	185.1	2.03	39.5	A
Palm Ave.	II	40	40.6	13.0	53.6	0.42	28.4	B
Gibsonton Dr	II	40	52.7	31.5	84.2	0.59	25.0	C
Riverview Dr	II	40	93.1	16.6	109.7	1.03	34.0	B
CR 676A (Madison Ave	II	45	222.0	40.7	262.7	2.77	38.0	A
Port Sutton Rd	II	45	34.3	11.7	46.0	0.36	28.0	C
Total	II		605.0	136.3	741.3	7.20	35.0	B

Arterial Level of Service: SB US 41

Cross Street	Arterial Class	Flow Speed	Running Time	Signal Delay	Travel Time (s)	Dist (mi)	Arterial Speed	Arterial LOS
Port Sutton Rd	II	45	92.6	10.5	103.1	1.16	40.4	A
Pendola Point Rd	II	45	34.3	13.2	47.5	0.36	27.1	C
Industrial Access Rd	II	45	222.0	17.7	239.7	2.77	41.7	A
Alice Ave	II	40	93.1	16.3	109.4	1.03	34.1	B
Palm Ave.	II	40	52.7	13.6	66.3	0.59	31.8	B
Symmes Rd	II	40	40.6	10.0	50.6	0.42	30.1	B
Total	II		535.3	81.3	616.6	6.33	37.0	A



## TWO-WAY STOP CONTROL SUMMARY

Analyst: AG  
 Agency/Co.: American  
 Date Performed: 07/15/2013  
 Analysis Time Period: PM Peak  
 Intersection: Kracker Avenue & US 41  
 Jurisdiction: FDOT D7  
 Units: U. S. Customary  
 Analysis Year: 2020 Build  
 Project ID: US 41 PD&E Study  
 East/West Street: Kracker Ave  
 North/South Street: US 41  
 Intersection Orientation: NS

Study period (hrs): 0.25

## Vehicle Volumes and Adjustments

Major Street:	Approach Movement	Northbound			Southbound		
		1 L	2 T	3 R	4 L	5 T	6 R
Volume		6	581	9	5	1084	4
Peak-Hour Factor, PHF		0.95	0.95	0.95	0.95	0.95	0.95
Hourly Flow Rate, HFR		6	611	9	5	1141	4
Percent Heavy Vehicles		5	--	--	5	--	--
Median Type/Storage		Raised curb			/ 1		
RT Channelized?							
Lanes		1	2	0	1	2	0
Configuration		L	T	TR	L	T	TR
Upstream Signal?		No			No		

Minor Street:	Approach Movement	Westbound			Eastbound		
		7 L	8 T	9 R	10 L	11 T	12 R
Volume		9	2	9	4	0	4
Peak Hour Factor, PHF		0.95	0.95	0.95	0.95	0.95	0.95
Hourly Flow Rate, HFR		9	2	9	4	0	4
Percent Heavy Vehicles		15	15	15	0	0	0
Percent Grade (%)		0			0		
Flared Approach: Exists?/Storage		/			/		
Lanes		0	1	1	0	1	1
Configuration		LT		R	LT		R

Delay, Queue Length, and Level of Service								
Approach Movement	NB	SB	Westbound			Eastbound		
	1	4	7	8	9	10	11	12
Lane Config	L	L	LT		R	LT		R
v (vph)	6	5	11		9	4		4
C(m) (vph)	589	936	226		689	173		523
v/c	0.01	0.01	0.05		0.01	0.02		0.01
95% queue length	0.03	0.02	0.15		0.04	0.07		0.02
Control Delay	11.2	8.9	21.7		10.3	26.3		11.9
LOS	B	A	C		B	D		B
Approach Delay					16.6			19.1
Approach LOS					C			C

## TWO-WAY STOP CONTROL SUMMARY

Analyst: AG  
 Agency/Co.: American  
 Date Performed: 07/15/2013  
 Analysis Time Period: PM Peak  
 Intersection: Ohio Street & US 41  
 Jurisdiction: FDOT D7  
 Units: U. S. Customary  
 Analysis Year: 2020 Build  
 Project ID: US 41 PD&E Study  
 East/West Street: Ohio Street  
 North/South Street: US 41  
 Intersection Orientation: NS

Study period (hrs): 0.25

## Vehicle Volumes and Adjustments

Major Street:	Approach Movement	Northbound			Southbound		
		1 L	2 T	3 R	4 L	5 T	6 R

Volume		597	13		84	1062	
Peak-Hour Factor, PHF		0.95	0.95		0.95	0.95	
Hourly Flow Rate, HFR		628	13		88	1117	
Percent Heavy Vehicles		--	--		5	--	--
Median Type/Storage		Raised curb			/ 1		
RT Channelized?							
Lanes		2	0		1	2	
Configuration		T	TR		L	T	
Upstream Signal?		No				No	

Minor Street:	Approach Movement	Westbound			Eastbound		
		7 L	8 T	9 R	10 L	11 T	12 R

Volume		17		30			
Peak Hour Factor, PHF		0.95		0.95			
Hourly Flow Rate, HFR		17		31			
Percent Heavy Vehicles		0		0			
Percent Grade (%)			0			0	
Flared Approach: Exists?/Storage					/		/
Lanes		1		1			
Configuration		L		R			

## Delay, Queue Length, and Level of Service

Approach Movement	NB	SB	Westbound			Eastbound		
	1	4	7	8	9	10	11	12

Lane Config		L	L		R			
v (vph)		88	17		31			
C(m) (vph)		919	259		725			
v/c		0.10	0.07		0.04			
95% queue length		0.32	0.21		0.13			
Control Delay		9.3	19.9		10.2			
LOS		A	C		B			
Approach Delay				13.6				
Approach LOS				B				

## TWO-WAY STOP CONTROL SUMMARY

Analyst: AG  
 Agency/Co.: American  
 Date Performed: 07/15/2013  
 Analysis Time Period: PM Peak  
 Intersection: Florence St & US 41  
 Jurisdiction: FDOT D7  
 Units: U. S. Customary  
 Analysis Year: 2020 Build  
 Project ID: US 41 PD&E Study  
 East/West Street: Florence Street  
 North/South Street: US 41  
 Intersection Orientation: NS

Study period (hrs): 0.25

## Vehicle Volumes and Adjustments

Major Street: Approach Movement	Northbound			Southbound		
	1 L	2 T	3 R	4 L	5 T	6 R
Volume	10	615	1	5	1087	14
Peak-Hour Factor, PHF	0.95	0.95	0.95	0.95	0.95	0.95
Hourly Flow Rate, HFR	10	647	1	5	1144	14
Percent Heavy Vehicles	5	--	--	5	--	--
Median Type/Storage	Raised curb			/ 1		
RT Channelized?						
Lanes	1	2	0	1	2	0
Configuration	L	T	TR	L	T	TR
Upstream Signal?	No			No		

Minor Street: Approach Movement	Westbound			Eastbound		
	7 L	8 T	9 R	10 L	11 T	12 R
Volume	3	0	10	16	0	6
Peak Hour Factor, PHF	0.95	0.95	0.95	0.95	0.95	0.95
Hourly Flow Rate, HFR	3	0	10	16	0	6
Percent Heavy Vehicles	0	0	0	0	0	0
Percent Grade (%)	0			0		
Flared Approach: Exists?/Storage	No			/ No /		
Lanes	0	1	0	0	1	0
Configuration	LTR			LTR		

## Delay, Queue Length, and Level of Service

Approach Movement	NB	SB	Westbound			Eastbound		
	1 L	4 L	7 L	8 LTR	9 L	10 L	11 LTR	12 R
v (vph)	10	5	13			22		
C(m) (vph)	582	914	508			207		
v/c	0.02	0.01	0.03			0.11		
95% queue length	0.05	0.02	0.08			0.35		
Control Delay	11.3	9.0	12.3			24.4		
LOS	B	A	B			C		
Approach Delay	12.3			24.4				
Approach LOS	B			C				

HCM Signalized Intersection Capacity Analysis  
 35: Symmes Rd & US 41

7/22/2013



Movement	EBL	EBT	EBR	WBL	WBT	WBR	NBL	NBT	NBR	SBL	SBT	SBR
Lane Configurations		↕		↕↕	↕	↕	↕	↑↑↑	↕	↕↕	↑↑↑	
Volume (vph)	0	2	0	117	0	134	2	815	98	377	1454	4
Ideal Flow (vphpl)	1900	1900	1900	1900	1900	1900	1900	1900	1900	1900	1900	1900
Total Lost time (s)		7.2		7.2	7.2	7.2	6.2	6.2	7.2	7.0	6.2	
Lane Util. Factor		1.00		0.97	0.95	0.95	1.00	0.91	1.00	0.97	0.91	
Flt Protected		1.00		1.00	0.85	0.85	1.00	1.00	0.85	1.00	1.00	
Satd. Flow (prot)		1900		3367	1475	1475	1719	4940	1538	3335	4938	
Flt Permitted		1.00		0.95	1.00	1.00	0.95	1.00	1.00	0.95	1.00	
Satd. Flow (perm)		1900		3367	1475	1475	1719	4940	1538	3335	4938	
Peak-hour factor, PHF	0.95	0.95	0.95	0.95	0.95	0.95	0.95	0.95	0.95	0.95	0.95	0.95
Adj. Flow (vph)	0	2	0	123	0	141	2	858	103	397	1531	4
RTOR Reduction (vph)	0	0	0	0	0	0	0	0	60	0	0	0
Lane Group Flow (vph)	0	2	0	123	71	70	2	858	43	397	1535	0
Heavy Vehicles (%)	0%	0%	0%	4%	4%	4%	5%	5%	5%	5%	5%	5%
Turn Type	Perm		Prot			pt+ov		Prot		pm+ov		Prot
Protected Phases	8		7			4		4.5		1		6
Permitted Phases	8									6		
Actuated Green, G (s)	1.1		5.3			13.6		29.9		0.6		22.0
Effective Green, g (s)	1.1		5.3			13.6		29.9		0.6		22.0
Actuated g/C Ratio	0.02		0.08			0.21		0.46		0.01		0.34
Clearance Time (s)	7.2		7.2			7.2		6.2		6.2		7.2
Vehicle Extension (s)	3.0		3.0			3.0		3.0		4.0		3.0
Lane Grp Cap (vph)	32		274			308		677		16		1669
v/s Ratio Prot	0.00		c0.04			0.05		c0.05		0.00		0.17
v/s Ratio Perm										0.01		c0.12
v/c Ratio	0.06		0.45			0.23		0.10		0.12		0.51
Uniform Delay, d1	31.5		28.5			21.4		10.0		32.0		17.3
Progression Factor	1.00		1.00			1.00		1.00		1.00		1.00
Incremental Delay, d2	0.8		1.2			0.4		0.1		3.5		0.4
Delay (s)	32.3		29.7			21.8		10.1		35.5		17.6
Level of Service	C		C			C		B		D		B
Approach Delay (s)	32.3					22.4				17.0		19.1
Approach LOS	C					C				B		B

Intersection Summary		
HCM Average Control Delay	18.8	HCM Level of Service
HCM Volume to Capacity ratio	0.61	B
Actuated Cycle Length (s)	65.1	Sum of lost time (s)
Intersection Capacity Utilization	57.9%	20.4
Analysis Period (min)	15	ICU Level of Service
		B

c Critical Lane Group

# HCM Signalized Intersection Capacity Analysis

46: Palm Ave. & US 41

7/22/2013



Movement	EBL	EBT	EBR	WBL	WBT	WBR	NBL	NBT	NBR	SEL	SBT	SBR
Lane Configurations		↔		↖	↗		↖	↑↑↑		↖	↑↑↑	
Volume (vph)	25	3	4	14	1	20	5	1004	10	49	1847	19
Ideal Flow (vphpl)	1900	1900	1900	1900	1900	1900	1900	1900	1900	1900	1900	1900
Total Lost time (s)		6.7		6.7	6.7		6.2	6.2		6.5	6.2	
Lane Util. Factor		1.00		1.00	1.00		1.00	0.91		1.00	0.91	
Frt		0.98		1.00	0.86		1.00	1.00		1.00	1.00	
Flt Protected		0.96		0.95	1.00		0.95	1.00		0.95	1.00	
Satd. Flow (prot)		1729		1805	1628		1719	4932		1719	4932	
Flt Permitted		0.76		0.74	1.00		0.95	1.00		0.95	1.00	
Satd. Flow (perm)		1360		1398	1628		1719	4932		1719	4932	
Peak-hour factor, PHF	0.95	0.95	0.95	0.95	0.95	0.95	0.95	0.95	0.95	0.95	0.95	0.95
Adj. Flow (vph)	26	3	4	15	1	21	5	1057	11	52	1944	20
RTOR Reduction (vph)	0	0	0	0	0	0	0	0	0	0	0	0
Lane Group Flow (vph)	0	33	0	15	22	0	5	1068	0	52	1964	0
Heavy Vehicles (%)	4%	4%	4%	0%	0%	0%	5%	5%	5%	5%	5%	5%
Turn Type	Perm			Perm			Prot			Prot		
Protected Phases	8			4			1			6		
Permitted Phases	8			4								
Actuated Green, G (s)	7.5			7.5			5.3			33.3		
Effective Green, g (s)	7.5			7.5			5.3			33.3		
Actuated g/C Ratio	0.12			0.12			0.08			0.52		
Clearance Time (s)	6.7			6.7			6.2			6.2		
Vehicle Extension (s)	3.0			3.0			4.0			4.0		
Lane Grp Cap (vph)	159			164			190			142		
v/s Ratio Prot				0.01			0.00			0.22		
v/s Ratio Perm	c0.02			0.01						c0.03		
v/c Ratio	0.21			0.09			0.12			0.04		
Uniform Delay, d1	25.6			25.3			25.3			27.0		
Progression Factor	1.00			1.00			1.00			1.00		
Incremental Delay, d2	0.7			0.2			0.3			0.1		
Delay (s)	26.3			25.5			25.6			27.2		
Level of Service	C			C			C			A		
Approach Delay (s)	26.3			25.6			9.7			15.5		
Approach LOS	C			C			A			B		

## Intersection Summary

HCM Average Control Delay	13.8	HCM Level of Service	B
HCM Volume to Capacity ratio	0.65		
Actuated Cycle Length (s)	64.1	Sum of lost time (s)	19.4
Intersection Capacity Utilization	59.9%	ICU Level of Service	B
Analysis Period (min)	15		

c Critical Lane Group

TWO-WAY STOP CONTROL SUMMARY

Analyst: AG  
 Agency/Co.: American  
 Date Performed: 07/15/2013  
 Analysis Time Period: PM Peak  
 Intersection: Nundy Ave & US 41  
 Jurisdiction: FDOT D7  
 Units: U. S. Customary  
 Analysis Year: 2020 Build  
 Project ID: US 41 PD&E Study  
 East/West Street: Nundy Ave  
 North/South Street: US 41  
 Intersection Orientation: NS Study period (hrs): 0.25

Vehicle Volumes and Adjustments

Major Street: Approach Movement	Northbound			Southbound		
	1 L	2 T	3 R	4 L	5 T	6 R
Volume	12	663	58	51	1208	8
Peak-Hour Factor, PHF	0.95	0.95	0.95	0.95	0.95	0.95
Hourly Flow Rate, HFR	12	697	61	53	1271	8
Percent Heavy Vehicles	5	--	--	5	--	--
Median Type/Storage	Raised curb			/ 1		
RT Channelized?						
Lanes	1	2	0	1	2	0
Configuration	L	T	TR	L	T	TR
Upstream Signal?	No			Yes		

Minor Street: Approach Movement	Westbound			Eastbound		
	7 L	8 T	9 R	10 L	11 T	12 R
Volume	64	3	34	4	0	15
Peak Hour Factor, PHF	0.95	0.95	0.95	0.95	0.95	0.95
Hourly Flow Rate, HFR	67	3	35	4	0	15
Percent Heavy Vehicles	3	3	3	0	0	0
Percent Grade (%)	0			0		
Flared Approach: Exists?/Storage	/			No /		
Lanes	0	1	1	0	1	0
Configuration	LT		R		LTR	

Delay, Queue Length, and Level of Service

Approach Movement Lane Config	NB	SB	Westbound			Eastbound		
	1 L	4 L	7 LT	8	9 R	10	11 LTR	12
v (vph)	12	53	70		35		19	
C(m) (vph)	466	830	0		663		302	
v/c	0.03	0.06			0.05		0.06	
95% queue length	0.08	0.20			0.17		0.20	
Control Delay	12.9	9.6			10.7		17.7	
LOS	B	A	F		B		C	
Approach Delay							17.7	
Approach LOS							C	

# HCM Signalized Intersection Capacity Analysis

40: Alice Ave & US 41

7/22/2013



Movement	EBL	EBT	EBR	WBL	WBT	WBR	NBL	NBT	NBR	SBL	SBT	SBR
Lane Configurations		↕		↙↘	↑	↗↖	↘	↑↑↑	↗	↙↘	↑↑↑	
Volume (vph)	9	21	14	330	44	138	11	713	316	470	1533	16
Ideal Flow (vphpl)	1900	1900	1900	1900	1900	1900	1900	1900	1900	1900	1900	1900
Total Lost time (s)		9.0		9.0	9.0	9.0	6.1	6.1	6.1	6.7	6.1	
Lane Util. Factor		1.00		0.94	1.00	0.88	1.00	0.91	1.00	0.94	0.91	
Frt		0.96		1.00	1.00	0.85	1.00	1.00	0.85	1.00	1.00	
Flt Protected		0.99		0.95	1.00	1.00	0.95	1.00	1.00	0.95	1.00	
Satd. Flow (prot)		1697		4848	1810	2707	1719	4940	1538	4848	4932	
Flt Permitted		0.93		0.95	1.00	1.00	0.95	1.00	1.00	0.95	1.00	
Satd. Flow (perm)		1596		4848	1810	2707	1719	4940	1538	4848	4932	
Peak-hour factor, PHF	0.95	0.95	0.95	0.95	0.95	0.95	0.95	0.95	0.95	0.95	0.95	0.95
Adj Flow (vph)	9	22	15	347	46	145	12	751	333	495	1614	17
RTOR Reduction (vph)	0	0	0	0	0	0	0	0	0	0	0	0
Lane Group Flow (vph)	0	46	0	347	46	145	12	751	333	495	1631	0
Heavy Vehicles (%)	6%	6%	6%	5%	5%	5%	5%	5%	5%	5%	5%	5%
Turn Type	Perm			Prot		pt+ov	Prot		pt+ov	Prot		
Protected Phases		8		7	4	4 5	1	6	6 7	5	2	
Permitted Phases	8											
Actuated Green, G (s)		16.0		7.0	32.0	52.9	0.8	29.2	42.3	11.9	40.9	
Effective Green, g (s)		16.0		7.0	32.0	52.9	0.8	29.2	42.3	11.9	40.9	
Actuated g/C Ratio		0.17		0.07	0.34	0.56	0.01	0.31	0.45	0.13	0.43	
Clearance Time (s)		9.0		9.0	9.0		6.1	6.1		6.7	6.1	
Vehicle Extension (s)		3.0		3.0	6.0		3.0	8.0		3.0	8.0	
Lane Grp Cap (vph)		269		358	610	1509	14	1520	686	608	2126	
v/s Ratio Prot				c0.07	0.03	0.05	0.01	0.15	0.22	c0.10	c0.33	
v/s Ratio Perm		c0.03										
v/c Ratio		0.17		0.97	0.08	0.10	0.86	0.49	0.49	0.81	0.77	
Uniform Delay, d1		33.8		43.8	21.4	9.8	47.0	26.8	18.6	40.4	23.0	
Progression Factor		1.00		1.00	1.00	1.00	1.00	1.00	1.00	1.00	1.00	
Incremental Delay, d2		1.4		38.9	0.2	0.1	164.6	1.2	0.5	11.4	2.7	
Delay (s)		35.1		82.8	21.6	9.9	211.6	28.0	19.1	51.8	25.7	
Level of Service		D		F	C	A	F	C	B	D	C	
Approach Delay (s)		35.1			57.9			27.3			31.8	
Approach LOS		D			E			C			C	

## Intersection Summary

HCM Average Control Delay	34.2	HCM Level of Service	C
HCM Volume to Capacity ratio	0.69		
Actuated Cycle Length (s)	94.9	Sum of lost time (s)	30.8
Intersection Capacity Utilization	63.9%	ICU Level of Service	B
Analysis Period (min)	15		

c Critical Lane Group

# HCM Signalized Intersection Capacity Analysis

## 9: Industrial Access Rd & US 41

7/22/2013



Movement	EBL	EBT	EBR	WBL	WBT	WBR	NBL	NBT	NBR	SBL	SBT	SBR
Lane Configurations	↖	↑	↗	↖↗	↑	↗	↖	↑↑↑	↗	↖	↑↑↑	↗
Volume (vph)	25	42	52	329	7	32	16	789	317	111	1728	12
Ideal Flow (vphpl)	1900	1900	1900	1900	1900	1900	1900	1900	1900	1900	1900	1900
Total Lost time (s)	6.3	6.3	6.4	6.3	6.3	6.3	6.4	6.4	6.3	6.4	6.4	6.4
Lane Util. Factor	1.00	1.00	1.00	0.94	1.00	1.00	1.00	0.91	1.00	1.00	0.91	1.00
Frt	1.00	1.00	0.85	1.00	1.00	0.85	1.00	1.00	0.85	1.00	1.00	0.85
Flt Protected	0.95	1.00	1.00	0.95	1.00	1.00	0.95	1.00	1.00	0.95	1.00	1.00
Satd. Flow (prot)	1787	1881	1599	4990	1863	1583	1719	4940	1538	1719	4940	1538
Flt Permitted	0.75	1.00	1.00	0.95	1.00	1.00	0.95	1.00	1.00	0.95	1.00	1.00
Satd. Flow (perm)	1417	1881	1599	4990	1863	1583	1719	4940	1538	1719	4940	1538
Peak-hour factor, PHF	0.95	0.95	0.95	0.95	0.95	0.95	0.95	0.95	0.95	0.95	0.95	0.95
Adj. Flow (vph)	26	44	55	346	7	34	17	831	334	117	1819	13
RTOR Reduction (vph)	0	0	3	0	0	0	0	0	164	0	0	0
Lane Group Flow (vph)	26	44	52	346	7	34	17	831	170	117	1819	13
Heavy Vehicles (%)	1%	1%	1%	2%	2%	2%	5%	5%	5%	5%	5%	5%
Turn Type	Perm		pm+ov	Prot		Prot	Prot		pm+ov	Prot		Prot
Protected Phases		8	1	7	4	4	1	6	7	5	2	2
Permitted Phases	8		8					6				
Actuated Green, G (s)	6.1	6.1	8.2	8.4	20.8	20.8	2.1	33.0	41.4	8.5	39.4	39.4
Effective Green, g (s)	6.1	6.1	8.2	8.4	20.8	20.8	2.1	33.0	41.4	8.5	39.4	39.4
Actuated g/C Ratio	0.07	0.07	0.10	0.10	0.26	0.26	0.03	0.41	0.51	0.10	0.48	0.48
Clearance Time (s)	6.3	6.3	6.4	6.3	6.3	6.3	6.4	6.4	6.3	6.4	6.4	6.4
Vehicle Extension (s)	6.0	6.0	3.0	3.0	6.0	6.0	3.0	8.0	3.0	3.0	8.0	8.0
Lane Grp Cap (vph)	106	141	161	515	476	405	44	2003	782	180	2391	744
v/s Ratio Prot		0.02	c0.01	c0.07	0.00	0.02	0.01	0.17	0.02	c0.07	c0.37	0.01
v/s Ratio Perm	0.02		0.02						0.09			
v/c Ratio	0.25	0.31	0.32	0.67	0.01	0.08	0.39	0.41	0.22	0.65	0.76	0.02
Uniform Delay, d1	35.5	35.7	34.0	35.2	22.6	23.1	39.0	17.3	11.0	35.0	17.2	10.9
Progression Factor	1.00	1.00	1.00	1.00	1.00	1.00	1.00	1.00	1.00	1.00	1.00	1.00
Incremental Delay, d2	3.4	3.5	1.2	3.4	0.0	0.3	5.6	0.6	0.1	8.1	2.3	0.0
Delay (s)	38.9	39.2	35.2	38.6	22.7	23.3	44.6	17.9	11.2	43.1	19.5	11.0
Level of Service	D	D	D	D	C	C	D	B	B	D	B	B
Approach Delay (s)		37.4			37.0			16.4			20.9	
Approach LOS		D			D			B			C	

### Intersection Summary

HCM Average Control Delay	21.7	HCM Level of Service	C
HCM Volume to Capacity ratio	0.74		
Actuated Cycle Length (s)	81.4	Sum of lost time (s)	25.5
Intersection Capacity Utilization	65.6%	ICU Level of Service	C
Analysis Period (min)	15		

c Critical Lane Group



# HCM Signalized Intersection Capacity Analysis

## 10: Pendola Point Rd & US 41

7/22/2013



Movement	EBL	EBT	EBR	WBL	WBT	WBR	NBL	NBT	NBR	SBL	SBT	SBR
Lane Configurations	↖	↗		↖	↗	↖↗↘	↖	↗↘↙	↗	↖↗↘	↗↘↙	↖
Volume (vph)	101	48	11	120	0	219	2	977	51	437	1808	5
Ideal Flow (vphpl)	1900	1900	1900	1900	1900	1900	1900	1900	1900	1900	1900	1900
Total Lost time (s)	8.1	8.1		7.1		7.1	7.5	7.5	7.5	7.5	7.5	7.5
Lane Util. Factor	1.00	1.00		1.00		0.76	1.00	0.91	1.00	0.94	0.91	1.00
Flt Protected	1.00	0.97		1.00		0.85	1.00	1.00	0.85	1.00	1.00	0.85
Flt Permitted	0.95	1.00		0.95		1.00	0.95	1.00	1.00	0.95	1.00	1.00
Satd. Flow (prot)	1583	1619		1656		3378	1719	4940	1538	4848	4940	1538
Satd. Flow (perm)	1168	1619		1248		3378	1719	4940	1538	4848	4940	1538
Peak-hour factor, PHF	0.95	0.95	0.95	0.95	0.95	0.95	0.95	0.95	0.95	0.95	0.95	0.95
Adj. Flow (vph)	106	51	12	126	0	231	2	1028	54	460	1903	5
RTOR Reduction (vph)	0	10	0	0	0	0	0	0	35	0	0	3
Lane Group Flow (vph)	106	53	0	126	0	231	2	1028	19	460	1903	2
Heavy Vehicles (%)	14%	14%	14%	9%	9%	9%	5%	5%	5%	5%	5%	5%
Turn Type	pm+pt			pm+pt		pt+ov	Prot		Perm	Prot		Perm
Protected Phases	3	8		7	4	4 5	1	6		5	2	
Permitted Phases	8			4					6			2
Actuated Green, G (s)	15.2	12.1		15.4		32.6	0.8	32.6	32.6	13.3	45.1	45.1
Effective Green, g (s)	15.2	12.1		15.4		32.6	0.8	32.6	32.6	13.3	45.1	45.1
Actuated g/C Ratio	0.17	0.13		0.17		0.36	0.01	0.36	0.36	0.15	0.49	0.49
Clearance Time (s)	8.1	8.1		7.1			7.5	7.5	7.5	7.5	7.5	7.5
Vehicle Extension (s)	3.0	6.0		3.0			6.0	8.0	8.0	6.0	8.0	8.0
Lane Grp Cap (vph)	208	214		225		1205	15	1762	549	705	2438	759
v/s Ratio Prot	0.02	0.03		c0.02		0.07	0.00	0.21		c0.09	c0.39	
v/s Ratio Perm	0.07			c0.07					0.01			0.00
v/c Ratio	0.51	0.25		0.56		0.19	0.13	0.58	0.04	0.65	0.78	0.00
Uniform Delay, d1	34.5	35.6		34.4		20.3	45.0	23.9	19.2	36.9	19.1	11.7
Progression Factor	1.00	1.00		1.00		1.00	1.00	1.00	1.00	1.00	1.00	1.00
Incremental Delay, d2	2.0	1.7		3.2		0.2	11.1	1.4	0.1	3.5	2.6	0.0
Delay (s)	36.5	37.3		37.6		20.5	56.1	25.3	19.3	40.3	21.6	11.8
Level of Service	D	D		D		C	E	C	B	D	C	B
Approach Delay (s)		36.8			26.5			25.1			25.2	
Approach LOS		D			C			C			C	

### Intersection Summary

HCM Average Control Delay	25.8	HCM Level of Service	C
HCM Volume to Capacity ratio	0.77		
Actuated Cycle Length (s)	91.4	Sum of lost time (s)	29.2
Intersection Capacity Utilization	70.0%	ICU Level of Service	C
Analysis Period (min)	15		

c Critical Lane Group

HCM Signalized Intersection Capacity Analysis  
 17: Port Sutton Rd & US 41

7/22/2013



Movement	EBL	EBR	NBL	NBT	SBU	SBT	SBR
Lane Configurations	↙	↘	↙	↑↑↑	↘	↑↑↑	↘
Volume (vph)	93	65	0	1251	1	2307	4
Ideal Flow (vphpl)	1900	1900	1900	1900	1900	1900	1900
Total Lost time (s)	7.7	7.0		6.7	6.4	6.7	7.7
Lane Util. Factor	1.00	1.00		0.91	1.00	0.91	1.00
Frt	1.00	0.85		1.00	1.00	1.00	0.85
Flt Protected	0.95	1.00		1.00	0.95	1.00	1.00
Satd. Flow (prot)	1805	1615		4940	1719	4940	1538
Flt Permitted	0.95	1.00		1.00	0.95	1.00	1.00
Satd. Flow (perm)	1805	1615		4940	1719	4940	1538
Peak-hour factor, PHF	0.95	0.95	0.95	0.95	0.95	0.95	0.95
Adj. Flow (vph)	98	68	0	1317	1	2428	4
RTOR Reduction (vph)	0	2	0	0	0	0	1
Lane Group Flow (vph)	98	66	0	1317	1	2428	3
Heavy Vehicles (%)	0%	0%	5%	5%	5%	5%	5%
Turn Type	pm+ov		Prot		Prot		pm+ov
Protected Phases	8	1	1	6	5	2	8
Permitted Phases	8						2
Actuated Green, G (s)	10.5	14.3		59.3	0.9	55.8	66.3
Effective Green, g (s)	10.5	14.3		59.3	0.9	55.8	66.3
Actuated g/C Ratio	0.11	0.16		0.65	0.01	0.61	0.72
Clearance Time (s)	7.7	7.0		6.7	6.4	6.7	7.7
Vehicle Extension (s)	6.0	3.0		8.0	3.0	8.0	6.0
Lane Grp Cap (vph)	207	252		3202	17	3013	1114
v/s Ratio Prot	c0.05	c0.01		c0.27	0.00	c0.49	0.00
v/s Ratio Perm		0.03					0.00
v/c Ratio	0.47	0.26		0.41	0.06	0.81	0.00
Uniform Delay, d1	37.9	34.0		7.7	44.9	13.7	3.5
Progression Factor	1.00	1.00		1.00	1.00	1.00	1.00
Incremental Delay, d2	4.8	0.6		0.4	1.5	2.4	0.0
Delay (s)	42.7	34.5		8.1	46.3	16.1	3.5
Level of Service	D	C		A	D	B	A
Approach Delay (s)	39.3			8.1		16.1	
Approach LOS	D			A		B	

Intersection Summary

HCM Average Control Delay	14.4	HCM Level of Service	B
HCM Volume to Capacity ratio	0.81		
Actuated Cycle Length (s)	91.5	Sum of lost time (s)	28.1
Intersection Capacity Utilization	62.4%	ICU Level of Service	B
Analysis Period (min)	15		

c Critical Lane Group

## TWO-WAY STOP CONTROL SUMMARY

Analyst: AG  
 Agency/Co.: American  
 Date Performed: 07/15/2013  
 Analysis Time Period: PM Peak  
 Intersection: Hartford St & US 41  
 Jurisdiction: FDOT D7  
 Units: U. S. Customary  
 Analysis Year: 2020 Build  
 Project ID: US 41 PD&E Study  
 East/West Street: Hartford Street  
 North/South Street: US 41  
 Intersection Orientation: NS Study period (hrs): 0.25

## Vehicle Volumes and Adjustments

Major Street: Approach Movement	Northbound			Southbound		
	1 L	2 T	3 R	4 L	5 T	6 R
Volume	8	835	24	46	1693	2
Peak-Hour Factor, PHF	0.95	0.95	0.95	0.95	0.95	0.95
Hourly Flow Rate, HFR	8	878	25	48	1782	2
Percent Heavy Vehicles	5	--	--	5	--	--
Median Type/Storage	Raised curb			/ 1		
RT Channelized?						
Lanes	1	2	0	1	2	0
Configuration	L	T	TR	L	T	TR
Upstream Signal?	No			No		

Minor Street: Approach Movement	Westbound			Eastbound		
	7 L	8 T	9 R	10 L	11 T	12 R
Volume	24	0	67	11	0	7
Peak Hour Factor, PHF	0.95	0.95	0.95	0.95	0.95	0.95
Hourly Flow Rate, HFR	25	0	70	11	0	7
Percent Heavy Vehicles	13	13	13	10	10	10
Percent Grade (%)	0			0		
Flared Approach: Exists?/Storage	/			/ No /		
Lanes	0	1	1	0	1	0
Configuration	LT		R	LTR		

## Delay, Queue Length, and Level of Service

Approach Movement	NB	SB	Westbound			Eastbound		
	1	4	7	8	9	10	11	12
Lane Config	L	L	LT		R		LTR	
v (vph)	8	48	25		70		18	
C(m) (vph)	331	730	125		574		78	
v/c	0.02	0.07	0.20		0.12		0.23	
95% queue length	0.07	0.21	0.71		0.41		0.81	
Control Delay	16.1	10.3	40.9		12.1		64.5	
LOS	C	B	E		B		F	
Approach Delay				19.7				64.5
Approach LOS				C				F

Arterial Level of Service: NB US 41

Cross Street	Arterial Class	Flow Speed	Running Time	Signal Delay	Travel Time (s)	Dist (mi)	Arterial Speed	Arterial LOS
Symmes Rd	II	45	162.3	18.0	180.3	2.03	40.5	A
Palm Ave.	II	40	40.6	10.1	50.7	0.42	30.0	B
Gibson Dr	II	40	52.7	30.2	82.9	0.59	25.4	C
Riverview Dr	II	40	93.1	19.5	112.6	1.03	33.1	B
CR 676A (Madison Ave)	II	45	222.0	28.0	250.0	2.77	39.9	A
Port Sutton Rd	II	45	34.3	7.4	41.7	0.36	30.9	B
Total	II		605.0	113.2	718.2	7.20	36.1	A

Arterial Level of Service: SB US 41

Cross Street	Arterial Class	Flow Speed	Running Time	Signal Delay	Travel Time (s)	Dist (mi)	Arterial Speed	Arterial LOS
Port Sutton Rd	II	45	92.6	18.1	110.7	1.16	37.6	A
Pendola Point Rd	II	45	34.3	18.6	52.9	0.36	24.3	C
Industrial Access Rd	II	45	222.0	19.0	241.0	2.77	41.4	A
Alice Ave	II	40	93.1	23.4	116.5	1.03	32.0	B
Palm Ave.	II	40	52.7	17.9	70.6	0.59	29.9	B
Symmes Rd	II	40	40.6	10.4	51.0	0.42	29.8	B
Total	II		535.3	107.4	642.7	6.33	35.5	A

# Appendix I

## Intersection Turn Lane Storage Lengths

**RECOMMENDED STORAGE LANE LENGTHS**  
(Based on Year 2040 - AM Peak - Directional Design Hour Volumes)

Intersection Approach & Lane Group	Existing Storage Lengths per Lane (without taper)(ft)	(1) AM Peak Hour Traffic (VPH)	(2) Cycle Length (Sec.)	(3) (1- g/c)	(4) No. of Prop. Lanes	(5) Percent Trucks	(6)	(7)	(8)	(9)	Foot Notes	
							Req Queue (ft)	"L" Distance	Column (6)	Recommended		
							From ITE Formula	From Index No. 301 (ft)	+ Column (7) (feet)	Lane Lengths <sup>1</sup> (ft.)		
<b>US 41 &amp; Symmes Road Intersection</b>												
EB	Left-Thru-Right	-	1	158.1	0.94	1	0.00%	2	0	2	25	2
WB	Left-Thru	140	311	158.1	0.59	1	6.00%	427	155	582	600	3
	Right	-	728	158.1	0.59	1	6.00%	1000	0	1000	1000	3
NB	Left	-	17	158.1	0.98	1	5.00%	38	240	278	300	5
	Thru	-	2019	158.1	0.64	3	5.00%	993	0	993	1000	5
SB	Right	255	218	158.1	0.33	1	5.00%	166	240	406	425	5
	Left	810	211	158.1	0.90	1	5.00%	438	185	623	625	4
	Thru-Right	-	1236	158.1	0.56	3	5.00%	532	0	532	550	4
<b>US 41 &amp; Palm Avenue Intersection</b>												
EB	Left-Thru-Right	-	71	82.1	0.88	1	0.00%	71	0	71	75	2
WB	Left	50	4	82.1	0.88	1	0.00%	4	145	149	150	2
	Thru-Right	-	29	82.1	0.88	1	0.00%	29	0	29	50	2
NB	Left	120	5	82.1	0.93	1	5.00%	6	185	191	200	4
	Thru-Right	-	2598	82.1	0.39	3	5.00%	404	0	404	425	4
SB	Left	170	41	82.1	0.97	1	5.00%	48	185	233	250	4
	Thru-Right	-	1398	82.1	0.42	3	5.00%	234	0	234	250	4
<b>US 41 &amp; Gibsonton Drive Intersection</b>												
EB	Left-Thru-Right	-	68	152.4	0.90	1	0.00%	130	0	130	150	2
WB	Left	150	499	152.4	0.78	1	6.00%	873	240	1113	1125	5
	Thru	-	99	152.4	0.62	1	6.00%	138	0	138	150	5
NB	Right	Continuous	771	152.4	0.47	1	6.00%	813	240	1053	1075	5
	Left	75	17	152.4	0.98	1	5.00%	37	185	222	225	4
SB	Thru	-	2281	152.4	0.61	3	5.00%	1031	0	1031	1050	4
	Right	160	318	152.4	0.35	1	5.00%	247	185	432	450	4
SB	Left	400	358	152.4	0.91	2	5.00%	362	185	547	550	4
	Thru-Right	-	1367	152.4	0.54	3	5.00%	547	0	547	550	4

Notes: 1. The distance "L" in column 7 is the total deceleration distance

<sup>1</sup> All recommendations rounded to nearest 25 ft.    <sup>2</sup> The 145 ft from Index 301, based on design speed of 35 mph.    <sup>3</sup> The 155 ft from Index 301, based on design speed of 40 mph.

<sup>4</sup> The 185 ft from Index 301, based on design speed of 45 mph.    <sup>5</sup> The 240 ft from Index 301, based on design speed of 50 mph.

The ITE "red-time" formula is:  $L = \frac{(1-G/C)(Volume)(1+\% trucks)(K)(25 \text{ ft/vehicle})}{(\# \text{ cycles per hour})(\# \text{ traffic lanes})}$  where G = Green time, C = cycle length, and K = random arrival factor (varies from 1.5 to 2.0, depending on whether RTOR are allowed)

Source: ITE's Traffic Engineering Handbook, 1999.

**RECOMMENDED STORAGE LANE LENGTHS**  
(Based on Year 2040 - AM Peak - Directional Design Hour Volumes)

Intersection Approach & Lane Group	Existing Storage Lengths per Lane (without taper)(ft)	(1) AM Peak Hour Traffic (VPH)	(2) Cycle Length (Sec.)	(3) (1- g/c)	(4) No. of Prop. Lanes	(5) Percent Trucks	(6)	(7)	(8)	(9)	Foot Notes	
							Req Queue (ft)	"L" Distance	Column (6) + Column (7)	Recommended Lane Lengths <sup>1</sup> (ft.)		
							From ITE Formula	From Index No. 301 (ft)				
<b>US 41 &amp; Riverview Drive Intersection</b>												
EB	Left-Thru	-	27	150.6	0.71	1	14.00%	46	0	46	50	3
	Right	140	24	150.6	0.63	1	14.00%	36	155	191	200	3
WB	Left-Thru	-	654	150.6	0.71	1	6.00%	1030	0	1030	1050	3
	Right	150	402	150.6	0.71	1	6.00%	633	155	788	800	3
NB	Left	285	98	150.6	0.92	1	5.00%	198	185	383	400	4
	Thru	-	2714	150.6	0.44	3	5.00%	874	0	874	875	4
SB	Right	245	291	150.6	0.44	1	5.00%	281	185	466	475	4
	Left	290	28	150.6	0.98	1	5.00%	60	240	300	325	5
	Thru	-	1441	150.6	0.50	3	5.00%	527	0	527	550	5
	Right	265	49	150.6	0.50	1	5.00%	54	240	294	300	5
<b>US 41 &amp; Madison Avenue Intersection</b>												
EB	Left	150	65	153.0	0.84	1	56.00%	181	145	326	350	2
	Thru-Right	-	37	153.0	0.84	1	56.00%	103	0	103	125	2
WB	Left-Thru	-	165	153.0	0.84	1	10.00%	324	0	324	325	5
	Right	1115	921	153.0	0.65	2	10.00%	700	240	940	950	5
NB	Left	520	20	153.0	0.98	1	5.00%	44	240	284	300	5
	Thru	-	2628	153.0	0.45	3	5.00%	880	0	880	900	5
SB	Right	210	82	153.0	0.45	1	5.00%	82	240	322	325	5
	Left	860	485	153.0	0.86	2	5.00%	465	240	705	725	5
	Thru	-	1279	153.0	0.33	3	5.00%	314	0	314	325	5
	Right	250	89	153.0	0.33	1	5.00%	66	240	306	325	5
<b>US 41 &amp; Port Sutton Road Intersection</b>												
EB	Left	-	56	138.8	0.90	1	42.00%	138	145	283	300	2
	Right	235	20	138.8	0.85	1	42.00%	47	145	192	200	2
NB	Left	285	38	138.8	0.95	1	5.00%	73	240	313	325	5
	Thru	-	3295	138.8	0.26	3	5.00%	578	0	578	600	5
SB	Left	190	10	138.8	0.99	1	5.00%	20	240	260	275	5
	Thru	-	1831	138.8	0.30	3	5.00%	371	0	371	375	5
	Right	Continuous	129	138.8	0.20	1	5.00%	52	240	292	300	5

Notes: 1. The distance "L" in column 7 is the total deceleration distance

<sup>1</sup> All recommendations rounded to nearest 25 ft.    <sup>2</sup> The 145 ft from Index 301, based on design speed of 35 mph.    <sup>3</sup> The 155 ft from Index 301, based on design speed of 40 mph.

<sup>4</sup> The 185 ft from Index 301, based on design speed of 45 mph.    <sup>5</sup> The 240 ft from Index 301, based on design speed of 50 mph.

The ITE "red-time" formula is:

$$L = \frac{(1-G/C)(Volume)(1+\% trucks)(K)(25 \text{ ft/vehicle})}{(\# \text{ cycles per hour})(\# \text{ traffic lanes})}$$

where G = Green time, C = cycle length, and K = random arrival factor (varies from 1.5 to 2.0, depending on whether RTOR are allowed)

Source: ITE's Traffic Engineering Handbook, 1999.

**RECOMMENDED STORAGE LANE LENGTHS**

(Based on Year 2040 - AM Peak - Directional Design Hour Volumes with Truck Percentages from Special Counts)

Intersection Approach & Lane Group	Existing Storage Lengths per Lane (without taper)(ft)	(1) AM Peak Hour Traffic (VPH)	(2) Cycle Length (Sec.)	(3) (1- g/c)	(4) No. of Prop. Lanes	(5) Percent Trucks	(6)	(7)	(8)	(9)	Foot Notes	
							Req Queue (ft)	"L" Distance	Column (6) + Column (7)	Recommended Lane Lengths <sup>1</sup> (ft.)		
							From ITE Formula	From Index No. 301 (ft)	(feet)			
<b>US 41 &amp; Riverview Drive Intersection</b>												
EB	Left-Thru	-	27	150.6	0.71	1	8.30%	43	0	43	50	3
	Right	140	24	150.6	0.63	1	3.70%	33	155	188	200	3
WB	Left-Thru	-	654	150.6	0.71	1	5.90%	1029	0	1029	1050	3
	Right	150	402	150.6	0.71	1	9.50%	654	155	809	825	3
NB	Left	285	98	150.6	0.92	1	8.90%	205	185	390	400	4
	Thru	-	2714	150.6	0.44	3	10.70%	922	0	922	925	4
SB	Right	245	291	150.6	0.44	1	4.90%	281	185	466	475	4
	Left	290	28	150.6	0.98	1	2.80%	59	240	299	300	5
	Thru	-	1441	150.6	0.50	3	12.40%	565	0	565	575	5
	Right	265	49	150.6	0.50	1	0.00%	51	240	291	300	5
<b>US 41 &amp; Madison Avenue Intersection</b>												
EB	Left	150	65	153.0	0.84	1	39.20%	162	145	307	325	2
	Thru-Right	-	37	153.0	0.84	1	71.40%	113	0	113	125	2
WB	Left-Thru	-	165	153.0	0.84	1	33.30%	393	0	393	400	5
	Right	1115	921	153.0	0.65	2	25.20%	796	240	1036	1050	5
NB	Left	520	20	153.0	0.98	1	87.50%	78	240	318	325	5
	Thru	-	2628	153.0	0.45	3	10.60%	926	0	926	950	5
SB	Right	210	82	153.0	0.45	1	17.00%	92	240	332	350	5
	Left	860	485	153.0	0.86	2	16.40%	516	240	756	775	5
	Thru	-	1279	153.0	0.33	3	11.50%	333	0	333	350	5
	Right	250	89	153.0	0.33	1	53.80%	96	240	336	350	5
<b>US 41 &amp; Port Sutton Road Intersection</b>												
EB	Left	-	56	138.8	0.90	1	46.40%	142	145	287	300	2
	Right	235	20	138.8	0.85	1	50.00%	49	145	194	200	2
NB	Left	285	38	138.8	0.95	1	33.30%	93	240	333	350	5
	Thru	-	3295	138.8	0.26	3	50.00%	826	0	826	850	5
SB	Left	190	10	138.8	0.99	1	33.30%	25	240	265	275	5
	Thru	-	1831	138.8	0.30	3	12.20%	396	0	396	400	5
	Right	Continuous	129	138.8	0.20	1	45.90%	73	240	313	325	5

Notes: 1. The distance "L" in column 7 is the total deceleration distance

<sup>1</sup> All recommendations rounded to nearest 25 ft. <sup>2</sup> The 145 ft from Index 301, based on design speed of 35 mph. <sup>3</sup> The 155 ft from Index 301, based on design speed of 40 mph.

<sup>4</sup> The 185 ft from Index 301, based on design speed of 45 mph. <sup>5</sup> The 240 ft from Index 301, based on design speed of 50 mph.

The ITE "red-time" formula is:

$$L = \frac{(1-G/C)(Volume)(1+\% trucks)(K)(25 \text{ ft/vehicle})}{(\# \text{ cycles per hour})(\# \text{ traffic lanes})}$$

where G = Green time, C = cycle length, and K = random arrival factor (varies from 1.5 to 2.0, depending on whether RTOR are allowed)

Source: ITE's Traffic Engineering Handbook, 1999.



**RECOMMENDED STORAGE LANE LENGTHS**  
(Based on Year 2040 - PM Peak - Directional Design Hour Volumes)

Intersection Approach & Lane Group	Existing Storage Lengths per Lane (without taper)(ft)	(1) PM Peak Hour Traffic (VPH)	(2) Cycle Length (Sec.)	(3) (1- g/c)	(4) No. of Prop. Lanes	(5) Percent Trucks	(6)	(7) "L" Distance From Index No. 301 (ft)	(8) Column (6) + Column (7) (feet)	(9) Recommended Lane Lengths <sup>1</sup> (ft.)	Foot Notes	
							Req Queue (ft)					
							From ITE Formula					
<b>US 41 &amp; Symmes Road Intersection</b>												
EB	Left-Thru-Right	-	2	120.8	0.97	1	0.00%	3	0	3	25	2
WB	Left-Thru	140	215	120.8	0.71	1	4.00%	266	155	421	425	3
	Right	-	244	120.8	0.71	1	4.00%	302	0	302	325	3
NB	Left	-	3	120.8	0.99	1	5.00%	5	240	245	250	5
	Thru	-	1115	120.8	0.75	3	5.00%	491	0	491	500	5
SB	Right	255	134	120.8	0.54	1	5.00%	127	240	367	375	5
	Left	810	535	120.8	0.71	1	5.00%	669	185	854	875	4
	Thru-Right	-	2068	120.8	0.46	3	5.00%	559	0	559	575	4
<b>US 41 &amp; Palm Avenue Intersection</b>												
EB	Left-Thru-Right	-	48	84.1	0.90	1	4.00%	52	0	52	75	2
WB	Left	50	22	84.1	0.90	1	0.00%	23	145	168	175	2
	Thru-Right	-	31	84.1	0.90	1	0.00%	33	0	33	50	2
NB	Left	120	7	84.1	0.94	1	5.00%	8	185	193	200	4
	Thru-Right	-	1441	84.1	0.41	3	5.00%	242	0	242	250	4
SB	Left	170	66	84.1	0.92	1	5.00%	74	185	259	275	4
	Thru-Right	-	2522	84.1	0.39	3	5.00%	402	0	402	425	4
<b>US 41 &amp; Gibsonton Drive Intersection</b>												
EB	Left-Thru-Right	-	58	152.4	0.90	1	6.00%	117	0	117	125	2
WB	Left	150	573	152.4	0.82	1	5.00%	1044	240	1284	1300	5
	Thru	-	77	152.4	0.65	1	5.00%	111	0	111	125	5
	Right	Continuous	239	152.4	0.31	1	5.00%	165	240	405	425	5
NB	Left	75	16	152.4	0.98	1	5.00%	35	185	220	225	4
	Thru	-	996	152.4	0.77	3	5.00%	568	0	568	575	4
	Right	160	442	152.4	0.55	1	5.00%	540	185	725	750	4
SB	Left	400	722	152.4	0.72	2	5.00%	578	185	763	775	4
	Thru-Right	-	2381	152.4	0.50	3	5.00%	882	0	882	900	4
Notes: 1. The distance "L" in column 7 is the total deceleration distance <sup>1</sup> All recommendations rounded to nearest 25 ft. <sup>2</sup> The 145 ft from Index 301, based on design speed of 35 mph. <sup>3</sup> The 155 ft from Index 301, based on design speed of 40 mph. <sup>4</sup> The 185 ft from Index 301, based on design speed of 45 mph. <sup>5</sup> The 240 ft from Index 301, based on design speed of 50 mph.												
The ITE "red-time" formula is: $L = \frac{(1-G/C)(Volume)(1+\% trucks)(K)(25 \text{ ft/vehicle})}{(\# \text{ cycles per hour})(\# \text{ traffic lanes})}$ where G = Green time, C = cycle length, and K = random arrival factor (varies from 1.5 to 2.0, depending on whether RTOR are allowed)												
Source: ITE's Traffic Engineering Handbook, 1999.												

**RECOMMENDED STORAGE LANE LENGTHS**  
(Based on Year 2040 - PM Peak - Directional Design Hour Volumes)

Intersection Approach & Lane Group	Existing Storage Lengths per Lane (without taper)(ft)	(1) PM Peak Hour Traffic (VPH)	(2) Cycle Length (Sec.)	(3) (1- g/c)	(4) No. of Prop. Lanes	(5) Percent Trucks	(6)	(7) "L" Distance From Index No. 301 (ft)	(8) Column (6) + Column (7) (feet)	(9) Recommended Lane Lengths <sup>1</sup> (ft.)	Foot Notes	
							Req Queue (ft)					
							From ITE Formula					
<b>US 41 &amp; Riverview Drive Intersection</b>												
EB	Left-Thru	-	88	150.0	0.70	1	1.00%	130	0	130	150	3
	Right	140	68	150.0	0.67	1	1.00%	96	155	251	275	3
WB	Left-Thru	-	716	150.0	0.70	1	2.00%	1065	0	1065	1075	3
	Right	150	68	150.0	0.70	1	2.00%	101	155	256	275	3
NB	Left	285	25	150.0	0.97	1	5.00%	53	185	238	250	4
	Thru	-	1213	150.0	0.54	3	5.00%	478	0	478	500	4
	Right	245	488	150.0	0.54	1	5.00%	576	185	761	775	4
SB	Left	290	164	150.0	0.89	1	5.00%	319	240	559	575	5
	Thru	-	2549	150.0	0.45	3	5.00%	836	0	836	850	5
	Right	265	17	150.0	0.45	1	5.00%	17	240	257	275	5
<b>US 41 &amp; Madison Avenue Intersection</b>												
EB	Left	150	134	116.0	0.84	1	14.00%	207	145	352	375	2
	Thru-Right	-	78	116.0	0.84	1	14.00%	120	0	120	125	2
WB	Left-Thru	-	191	116.0	0.83	1	9.00%	278	0	278	300	5
	Right	1115	350	116.0	0.54	2	9.00%	166	240	406	425	5
NB	Left	520	3	116.0	0.99	1	5.00%	5	240	245	250	5
	Thru	-	1441	116.0	0.59	3	5.00%	479	0	479	500	5
	Right	210	75	116.0	0.59	1	5.00%	75	240	315	325	5
SB	Left	860	647	116.0	0.77	2	5.00%	421	240	661	675	5
	Thru	-	2678	116.0	0.37	3	5.00%	559	0	559	575	5
	Right	250	8	116.0	0.37	1	5.00%	5	240	245	250	5
<b>US 41 &amp; Port Sutton Road Intersection</b>												
EB	Left	-	139	154.8	0.90	1	0.00%	269	145	414	425	2
	Right	235	98	154.8	0.87	1	0.00%	183	145	328	350	2
NB	Left	285	0	154.8	0.99	1	5.00%	0	240	240	250	5
	Thru	-	1853	154.8	0.24	3	5.00%	335	0	335	350	5
SB	Left	190	2	154.8	0.99	1	5.00%	4	240	244	250	5
	Thru	-	3519	154.8	0.27	3	5.00%	715	0	715	725	5
	Right	Continuous	7	154.8	0.17	1	5.00%	3	240	243	250	5
Notes: 1. The distance "L" in column 7 is the total deceleration distance												
<sup>1</sup> All recommendations rounded to nearest 25 ft. <sup>2</sup> The 145 ft from Index 301, based on design speed of 35 mph. <sup>3</sup> The 155 ft from Index 301, based on design speed of 40 mph.												
<sup>4</sup> The 185 ft from Index 301, based on design speed of 45 mph. <sup>5</sup> The 240 ft from Index 301, based on design speed of 50 mph.												
The ITE "red-time" formula is: $L = \frac{(1-G/C)(Volume)(1+\% \text{ trucks})(K)(25 \text{ ft/vehicle})}{(\# \text{ cycles per hour})(\# \text{ traffic lanes})}$ where G = Green time, C = cycle length, and K = random arrival factor (varies from 1.5 to 2.0, depending on whether RTOR are allowed)												
Source: ITE's Traffic Engineering Handbook, 1999.												

**RECOMMENDED STORAGE LANE LENGTHS**

(Based on Year 2040 - PM Peak - Directional Design Hour Volumes with Truck Percentages from Special Counts)

Intersection Approach & Lane Group	Existing Storage Lengths per Lane (without taper)(ft)	(1) PM Peak Hour Traffic (VPH)	(2) Cycle Length (Sec.)	(3) (1- g/c)	(4) No. of Prop. Lanes	(5) Percent Trucks	(6)	(7) "L" Distance From Index No. 301 (ft)	(8) Column (6) + Column (7) (feet)	(9) Recommended Lane Lengths <sup>1</sup> (ft.)	Foot Notes	
							Req Queue (ft)					
							From ITE Formula					
<b>US 41 &amp; Riverview Drive Intersection</b>												
EB	Left-Thru	-	88	150.0	0.70	1	8.30%	139	0	139	150	3
	Right	140	68	150.0	0.67	1	3.70%	98	155	253	275	3
WB	Left-Thru	-	716	150.0	0.70	1	5.90%	1106	0	1106	1125	3
	Right	150	68	150.0	0.70	1	9.50%	109	155	264	275	3
NB	Left	285	25	150.0	0.97	1	8.90%	55	185	240	250	4
	Thru	-	1213	150.0	0.54	3	10.70%	504	0	504	525	4
	Right	245	488	150.0	0.54	1	4.90%	576	185	761	775	4
	Left	290	164	150.0	0.89	1	2.80%	313	240	553	575	5
	Thru	-	2549	150.0	0.45	3	12.40%	895	0	895	900	5
	Right	265	17	150.0	0.45	1	0.00%	16	240	256	275	5
<b>US 41 &amp; Madison Avenue Intersection</b>												
EB	Left	150	134	116.0	0.84	1	39.20%	252	145	397	400	2
	Thru-Right	-	78	116.0	0.84	1	71.40%	181	0	181	200	2
WB	Left-Thru	-	191	116.0	0.83	1	33.30%	340	0	340	350	5
	Right	1115	350	116.0	0.54	2	25.20%	191	240	431	450	5
NB	Left	520	3	116.0	0.99	1	87.50%	9	240	249	250	5
	Thru	-	1441	116.0	0.59	3	10.60%	505	0	505	525	5
	Right	210	75	116.0	0.59	1	17.00%	83	240	323	325	5
	Left	860	647	116.0	0.77	2	16.40%	467	240	707	725	5
	Thru	-	2678	116.0	0.37	3	11.50%	593	0	593	600	5
	Right	250	8	116.0	0.37	1	53.80%	7	240	247	250	5
<b>US 41 &amp; Port Sutton Road Intersection</b>												
EB	Left	-	139	154.8	0.90	1	46.40%	394	145	539	550	2
	Right	235	98	154.8	0.87	1	50.00%	275	145	420	425	2
NB	Left	285	0	154.8	0.99	1	33.30%	0	240	240	250	5
	Thru	-	1853	154.8	0.24	3	50.00%	478	0	478	500	5
SB	Left	190	2	154.8	0.99	1	33.30%	6	240	246	250	5
	Thru	-	3519	154.8	0.27	3	12.20%	764	0	764	775	5
	Right	Continuous	7	154.8	0.17	1	45.90%	4	240	244	250	5
Notes: 1. The distance "L" in column 7 is the total deceleration distance												
<sup>1</sup> All recommendations rounded to nearest 25 ft. <sup>2</sup> The 145 ft from Index 301, based on design speed of 35 mph. <sup>3</sup> The 155 ft from Index 301, based on design speed of 40 mph.												
<sup>4</sup> The 185 ft from Index 301, based on design speed of 45 mph. <sup>5</sup> The 240 ft from Index 301, based on design speed of 50 mph.												
The ITE "red-time" formula is: $L = \frac{(1-G/C)(Volume)(1+\% trucks)(K)(25 \text{ ft/vehicle})}{(\# \text{ cycles per hour})(\# \text{ traffic lanes})}$ where G = Green time, C = cycle length, and K = random arrival factor (varies from 1.5 to 2.0, depending on whether RTOR are allowed)												
Source: ITE's Traffic Engineering Handbook, 1999.												

**RECOMMENDED STORAGE LANE LENGTHS ALONG US 41 AT UNSIGNALIZED INTERSECTIONS**

(Based on Year 2040 - AM/PM Peak - Directional Design Hour Volumes)

Intersection		Existing Storage	(1)	(2)	(3)	(4)	(5)	(6)
Approach & Lane Group		Lengths per Lane (without taper)(ft)	AM/PM Peak Hour Traffic (VPH)	Storage Queue Length (feet)	Taper Length (feet)	Brake To Stop (feet)	Column (2) + Column (3) + Column (4) (feet)	Recommended Lane Lengths <sup>1</sup> (feet)
<b>US 41 &amp; Kracker Avenue Intersection</b>								
NB	Left	245	9/10	25	105	135	265	275
SB	Left	255	2/7	25	105	135	265	275
SB	Right	210	4/5	25	105	135	265	275
<b>US 41 &amp; Ohio Street Intersection</b>								
SB	Left	250	79/113	100	105	135	340	350
<b>US 41 &amp; Florence Street Intersection</b>								
NB	Left	255	8/13	25	105	135	265	275
SB	Left	230	4/7	25	105	135	265	275
<b>US 41 &amp; Nundy Avenue Intersection</b>								
NB	Left	75	16/16	25	85	100	210	225
SB	Left	75	41/72	100	85	100	285	300
<b>US 41 &amp; Hartford Street Intersection</b>								
NB	Left	50	14/12	25	105	135	265	275
SB	Left	65	113/70	100	105	135	340	350

Notes: <sup>1</sup> All recommendations rounded to nearest 25 ft.

**FIGURE 3 – 13  
 TYPICAL STORAGE LANE**

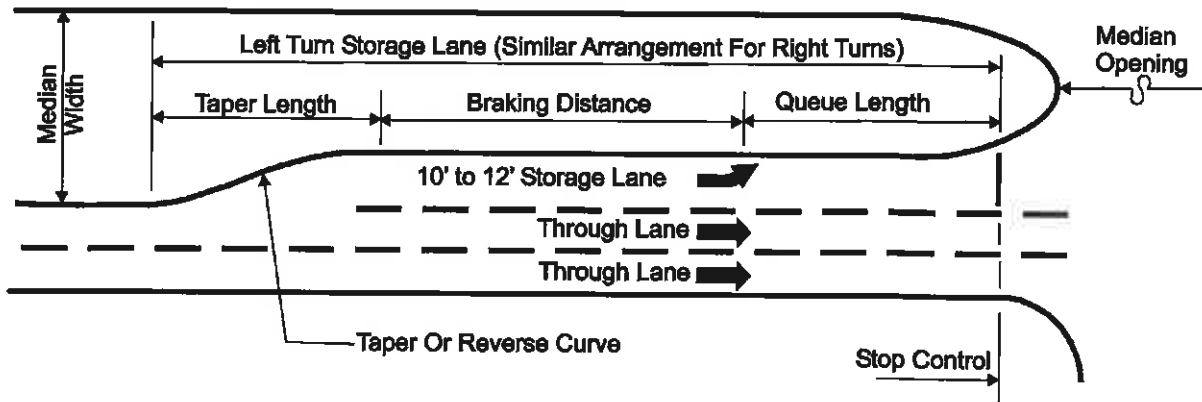

**Storage Queue Length - Unsignalized Intersections**

Turning Vehicles Per Hour	30	60	100	200	300
Required Storage Length (FEET)	25	50	100	175	250

At signalized intersections, the required queue length depends on the signal cycle length, the signal phasing arrangement, and rate of arrivals and departures of turning vehicles.

In absence of a turning movement study, it is recommended that 100 ft. of queue length be provided in urban/suburban areas and 50 ft. of queue length be provided in rural/town areas as a minimum.

**Taper Length And Braking Distance (FEET)**

Highway Design Speed (MPH)	Storage Entry Speed* (MPH)	Taper Length	Brake To Stop	
			Urban**	Rural***
35	25	70	75	---
40	30	80	75	---
45	35	85	100	---
50	40/44	105	135	215
55	48	125	---	260
60	52	145	---	310
65	55	170	---	350

\* Reaction Precedes Entry  
 \*\* Minimum Braking Distance, Wet Conditions  
 \*\*\* Customary Braking Distance, Wet Conditions

The storage lane may be in place of or in addition to deceleration length (See Section C.9.c.3).

# Appendix J

## Traffic Forms for Noise and Air Studies

Table 1 for Urbanized Areas of 2009 FDOT Quality/Level of Service Handbook was used for the LOS C volumes.

**TRAFFIC DATA FOR NOISE STUDIES**

Project: US 41 Date: 9/13/2013  
 Work Program Item Seg. No.: 430056-1 Prepared By: American  
 Financial Project ID Number(s): \_\_\_\_\_  
 Federal Aid Number(s): \_\_\_\_\_  
 Segment Description: US 41 from Kracker Avenue to Symmes Road Alternative: N/A

(Data sheets are to be filled out for every segment having a change in traffic parameters such as volumes, posted speeds, typical section, etc.)

NOTE: Modeled ADT is the LOS(C) volume referenced in the FDOT LOS tables or demand, whichever is less.

Existing Facility	No-Build (Design Year)	Build (Design Year)
Lanes: <u>4</u>	Lanes: <u>4</u>	Lanes: <u>6</u>
Year: <u>2013</u>	Year: <u>2040</u>	Year: <u>2040</u>
ADT: LOS (C) <u>35,500</u>	ADT: LOS (C) <u>35,500</u>	ADT: LOS (C) <u>53,700</u>
Demand <u>25,550</u>	Demand <u>42,100</u>	Demand <u>42,100</u>
Posted Spd: <u>55</u> mph <u>89</u> kmh	Posted Spd: <u>55</u> mph <u>89</u> kmh	Posted Spd: <u>45</u> mph <u>72</u> kmh
K= <u>9.00</u> %	K= <u>9.00</u> %	K= <u>9.00</u> %
D= <u>64.27</u> %	D= <u>64.27</u> %	D= <u>64.27</u> %
T= <u>9.0</u> % for 24 hrs.	T= <u>9.0</u> % for 24 hrs.	T= <u>9.0</u> % for 24 hrs.
T= <u>4.50</u> % Design hr	T= <u>4.50</u> % Design hr	T= <u>4.50</u> % Design hr
1.45 % Medium Trucks DHV	1.45 % Medium Trucks DHV	1.45 % Medium Trucks DHV
3.12 % Heavy Trucks DHV	3.12 % Heavy Trucks DHV	3.12 % Heavy Trucks DHV
0.07 % Buses DHV	0.07 % Buses DHV	0.07 % Buses DHV
0.20 % Motorcycles DHV	0.20 % Motorcycles DHV	0.20 % Motorcycles DHV

**STAMINA/TNM INPUT**

**The following are spreadsheet calculations based on the input above - do not enter data below this line**

Existing Facility Model: Demand	No-Build (Design Year) Model: LOS (C)	Build (Design Year) Model: Demand
LOS (C)	LOS (C)	LOS (C)
Peak: Autos <u>1954</u>	Peak: Autos <u>1954</u>	Peak: Autos <u>2956</u>
Med Trucks <u>30</u>	Med Trucks <u>30</u>	Med Trucks <u>45</u>
Hvy Trucks <u>64</u>	Hvy Trucks <u>64</u>	Hvy Trucks <u>97</u>
Buses <u>1</u>	Buses <u>1</u>	Buses <u>2</u>
Motorcycles <u>4</u>	Motorcycles <u>4</u>	Motorcycles <u>6</u>
Off Peak: Autos <u>1086</u>	Off Peak: Autos <u>1086</u>	Off Peak: Autos <u>1643</u>
Med Trucks <u>17</u>	Med Trucks <u>17</u>	Med Trucks <u>25</u>
Hvy Trucks <u>36</u>	Hvy Trucks <u>36</u>	Hvy Trucks <u>54</u>
Buses <u>1</u>	Buses <u>1</u>	Buses <u>1</u>
Motorcycles <u>2</u>	Motorcycles <u>2</u>	Motorcycles <u>3</u>
Demand	Demand	Demand
Peak: Autos <u>1406</u>	Peak: Autos <u>2317</u>	Peak: Autos <u>2317</u>
Med Trucks <u>21</u>	Med Trucks <u>35</u>	Med Trucks <u>35</u>
Hvy Trucks <u>46</u>	Hvy Trucks <u>76</u>	Hvy Trucks <u>76</u>
Buses <u>1</u>	Buses <u>2</u>	Buses <u>2</u>
Motorcycles <u>3</u>	Motorcycles <u>5</u>	Motorcycles <u>5</u>
Off Peak: Autos <u>782</u>	Off Peak: Autos <u>1288</u>	Off Peak: Autos <u>1288</u>
Med Trucks <u>12</u>	Med Trucks <u>20</u>	Med Trucks <u>20</u>
Hvy Trucks <u>26</u>	Hvy Trucks <u>42</u>	Hvy Trucks <u>42</u>
Buses <u>1</u>	Buses <u>1</u>	Buses <u>1</u>
Motorcycles <u>2</u>	Motorcycles <u>3</u>	Motorcycles <u>3</u>



### TRAFFIC DATA FOR NOISE STUDIES

Project: US 41 Date: 9/13/2013  
 Work Program Item Seg. No.: 430056-1 Prepared By: American  
 Financial Project ID Number(s): \_\_\_\_\_  
 Federal Aid Number(s): \_\_\_\_\_  
 Segment Description: US 41 from Symmes Road to Palm Avenue Alternative: N/A

(Data sheets are to be filled out for every segment having a change in traffic parameters such as volumes, posted speeds, typical section, etc.)

NOTE: Modeled ADT is the LOS(C) volume referenced in the FDOT LOS tables or demand, whichever is less.

Existing Facility	No-Build (Design Year)	Build (Design Year)
Lanes: <u>4</u>	Lanes: <u>4</u>	Lanes: <u>6</u>
Year: <u>2013</u>	Year: <u>2040</u>	Year: <u>2040</u>
ADT: LOS (C) <u>35,500</u>	ADT: LOS (C) <u>35,500</u>	ADT: LOS (C) <u>53,700</u>
Demand <u>27,050</u>	Demand <u>45,000</u>	Demand <u>45,000</u>
Posted Spd: <u>40</u> mph <u>64</u> kmh	Posted Spd: <u>40</u> mph <u>64</u> kmh	Posted Spd: <u>40</u> mph <u>64</u> kmh
K= <u>9.00</u> %	K= <u>9.00</u> %	K= <u>9.00</u> %
D= <u>64.27</u> %	D= <u>64.27</u> %	D= <u>64.27</u> %
T= <u>9.0</u> % for 24 hrs.	T= <u>9.0</u> % for 24 hrs.	T= <u>9.0</u> % for 24 hrs.
T= <u>4.50</u> % Design hr	T= <u>4.50</u> % Design hr	T= <u>4.50</u> % Design hr
1.33 % Medium Trucks DHV	1.33 % Medium Trucks DHV	1.33 % Medium Trucks DHV
3.20 % Heavy Trucks DHV	3.20 % Heavy Trucks DHV	3.20 % Heavy Trucks DHV
0.03 % Buses DHV	0.03 % Buses DHV	0.03 % Buses DHV
0.30 % Motorcycles DHV	0.30 % Motorcycles DHV	0.30 % Motorcycles DHV

STAMINA/TNM INPUT								
The following are spreadsheet calculations based on the input above - do not enter data below this line								
Existing Facility Model:	Demand	No-Build (Design Year) Model:	LOS (C)	Build (Design Year) Model:	Demand			
LOS (C)		LOS (C)		LOS (C)				
Peak:		Peak:		Peak:				
Autos	1954	Autos	1954	Autos	2955			
Med Trucks	27	Med Trucks	27	Med Trucks	41			
Hvy Trucks	66	Hvy Trucks	66	Hvy Trucks	99			
Buses	1	Buses	1	Buses	1			
Motorcycles	6	Motorcycles	6	Motorcycles	9			
Off Peak:		Off Peak:		Off Peak:				
Autos	1086	Autos	1086	Autos	1643			
Med Trucks	15	Med Trucks	15	Med Trucks	23			
Hvy Trucks	37	Hvy Trucks	37	Hvy Trucks	55			
Buses	0	Buses	0	Buses	1			
Motorcycles	3	Motorcycles	3	Motorcycles	5			
Demand		Demand		Demand				
Peak:		Peak:		Peak:				
Autos	1489	Autos	2476	Autos	2476			
Med Trucks	21	Med Trucks	35	Med Trucks	35			
Hvy Trucks	50	Hvy Trucks	83	Hvy Trucks	83			
Buses	0	Buses	1	Buses	1			
Motorcycles	5	Motorcycles	8	Motorcycles	8			
Off Peak:		Off Peak:		Off Peak:				
Autos	828	Autos	1377	Autos	1377			
Med Trucks	12	Med Trucks	19	Med Trucks	19			
Hvy Trucks	28	Hvy Trucks	46	Hvy Trucks	46			
Buses	0	Buses	0	Buses	0			
Motorcycles	3	Motorcycles	4	Motorcycles	4			

### TRAFFIC DATA FOR NOISE STUDIES

Project: US 41 Date: 9/13/2013  
 Work Program Item Seg. No.: 430056-1 Prepared By: American  
 Financial Project ID Number(s): \_\_\_\_\_  
 Federal Aid Number(s): \_\_\_\_\_  
 Segment Description: US 41 from Palm Avenue to Gibsonton Drive/Alice Avenue Alternative: N/A

(Data sheets are to be filled out for every segment having a change in traffic parameters such as volumes, posted speeds, typical section, etc.)

NOTE: Modeled ADT is the LOS(C) volume referenced in the FDOT LOS tables or demand, whichever is less.

Existing Facility	No-Build (Design Year)	Build (Design Year)
Lanes: <u>4</u>	Lanes: <u>4</u>	Lanes: <u>6</u>
Year: <u>2013</u>	Year: <u>2040</u>	Year: <u>2040</u>
ADT: LOS (C) <u>35,500</u>	ADT: LOS (C) <u>35,500</u>	ADT: LOS (C) <u>53,700</u>
Demand <u>29,050</u>	Demand <u>45,200</u>	Demand <u>45,200</u>
Posted Spd: <u>50</u> mph <u>80</u> kmh	Posted Spd: <u>40</u> mph <u>64</u> kmh	Posted Spd: <u>40</u> mph <u>64</u> kmh
K= <u>9.00</u> %	K= <u>9.00</u> %	K= <u>9.00</u> %
D= <u>64.27</u> %	D= <u>64.27</u> %	D= <u>64.27</u> %
T= <u>9.0</u> % for 24 hrs.	T= <u>9.0</u> % for 24 hrs.	T= <u>9.0</u> % for 24 hrs.
T= <u>4.50</u> % Design hr	T= <u>4.50</u> % Design hr	T= <u>4.50</u> % Design hr
1.33 % Medium Trucks DHV	1.33 % Medium Trucks DHV	1.33 % Medium Trucks DHV
3.20 % Heavy Trucks DHV	3.20 % Heavy Trucks DHV	3.20 % Heavy Trucks DHV
0.03 % Buses DHV	0.03 % Buses DHV	0.03 % Buses DHV
0.30 % Motorcycles DHV	0.30 % Motorcycles DHV	0.30 % Motorcycles DHV

#### STAMINA/TNM INPUT

The following are spreadsheet calculations based on the input above - do not enter data below this line

Existing Facility Model: Demand	No-Build (Design Year) Model: LOS (C)	Build (Design Year) Model: Demand
LOS (C)	LOS (C)	LOS (C)
Peak: Autos <u>1954</u>	Peak: Autos <u>1954</u>	Peak: Autos <u>2955</u>
Med Trucks <u>27</u>	Med Trucks <u>27</u>	Med Trucks <u>41</u>
Hvy Trucks <u>66</u>	Hvy Trucks <u>66</u>	Hvy Trucks <u>99</u>
Buses <u>1</u>	Buses <u>1</u>	Buses <u>1</u>
Motorcycles <u>6</u>	Motorcycles <u>6</u>	Motorcycles <u>9</u>
Off Peak: Autos <u>1086</u>	Off Peak: Autos <u>1086</u>	Off Peak: Autos <u>1643</u>
Med Trucks <u>15</u>	Med Trucks <u>15</u>	Med Trucks <u>23</u>
Hvy Trucks <u>37</u>	Hvy Trucks <u>37</u>	Hvy Trucks <u>55</u>
Buses <u>0</u>	Buses <u>0</u>	Buses <u>1</u>
Motorcycles <u>3</u>	Motorcycles <u>3</u>	Motorcycles <u>5</u>
Demand	Demand	Demand
Peak: Autos <u>1599</u>	Peak: Autos <u>2487</u>	Peak: Autos <u>2487</u>
Med Trucks <u>22</u>	Med Trucks <u>35</u>	Med Trucks <u>35</u>
Hvy Trucks <u>54</u>	Hvy Trucks <u>84</u>	Hvy Trucks <u>84</u>
Buses <u>1</u>	Buses <u>1</u>	Buses <u>1</u>
Motorcycles <u>5</u>	Motorcycles <u>8</u>	Motorcycles <u>8</u>
Off Peak: Autos <u>889</u>	Off Peak: Autos <u>1383</u>	Off Peak: Autos <u>1383</u>
Med Trucks <u>12</u>	Med Trucks <u>19</u>	Med Trucks <u>19</u>
Hvy Trucks <u>30</u>	Hvy Trucks <u>47</u>	Hvy Trucks <u>47</u>
Buses <u>0</u>	Buses <u>0</u>	Buses <u>0</u>
Motorcycles <u>3</u>	Motorcycles <u>4</u>	Motorcycles <u>4</u>

**TRAFFIC DATA FOR NOISE STUDIES**

Project: US 41 Date: 9/13/2013  
 Work Program Item Seg. No.: 430056-1 Prepared By: American  
 Financial Project ID Number(s): \_\_\_\_\_  
 Federal Aid Number(s): \_\_\_\_\_  
 Segment Description: US 41 from Gibsonton Drive/Alice Avenue to Riverview Drive/Industrial Access Road Alternative: N/A

(Data sheets are to be filled out for every segment having a change in traffic parameters such as volumes, posted speeds, typical section, etc.)

NOTE: Modeled ADT is the LOS(C) volume referenced in the FDOT LOS tables or demand, whichever is less.

Existing Facility	No-Build (Design Year)	Build (Design Year)
Lanes: <u>4</u>	Lanes: <u>4</u>	Lanes: <u>6</u>
Year: <u>2013</u>	Year: <u>2040</u>	Year: <u>2040</u>
ADT: <u>35,500</u>	ADT: <u>35,500</u>	ADT: <u>53,700</u>
LOS (C) <u>35,500</u>	LOS (C) <u>35,500</u>	LOS (C) <u>53,700</u>
Demand <u>28,350</u>	Demand <u>53,650</u>	Demand <u>53,650</u>
Posted Spd: <u>50</u> mph <u>80</u> kmh	Posted Spd: <u>40</u> mph <u>64</u> kmh	Posted Spd: <u>40</u> mph <u>64</u> kmh
K= <u>9.00</u> %	K= <u>9.00</u> %	K= <u>9.00</u> %
D= <u>64.27</u> %	D= <u>64.27</u> %	D= <u>64.27</u> %
T= <u>9.0</u> % for 24 hrs.	T= <u>9.0</u> % for 24 hrs.	T= <u>9.0</u> % for 24 hrs.
T= <u>4.50</u> % Design hr	T= <u>4.50</u> % Design hr	T= <u>4.50</u> % Design hr
<u>1.33</u> % Medium Trucks DHV	<u>1.33</u> % Medium Trucks DHV	<u>1.33</u> % Medium Trucks DHV
<u>3.20</u> % Heavy Trucks DHV	<u>3.20</u> % Heavy Trucks DHV	<u>3.20</u> % Heavy Trucks DHV
<u>0.03</u> % Buses DHV	<u>0.03</u> % Buses DHV	<u>0.03</u> % Buses DHV
<u>0.30</u> % Motorcycles DHV	<u>0.30</u> % Motorcycles DHV	<u>0.30</u> % Motorcycles DHV

**STAMINA/TNM INPUT**

**The following are spreadsheet calculations based on the input above - do not enter data below this line**

Existing Facility Model: Demand	No-Build (Design Year) Model: LOS (C)	Build (Design Year) Model: Demand
LOS (C)	LOS (C)	LOS (C)
Peak: Autos <u>1954</u>	Peak: Autos <u>1954</u>	Peak: Autos <u>2955</u>
Med Trucks <u>27</u>	Med Trucks <u>27</u>	Med Trucks <u>41</u>
Hvy Trucks <u>66</u>	Hvy Trucks <u>66</u>	Hvy Trucks <u>99</u>
Buses <u>1</u>	Buses <u>1</u>	Buses <u>1</u>
Motorcycles <u>6</u>	Motorcycles <u>6</u>	Motorcycles <u>9</u>
Off Peak: Autos <u>1086</u>	Off Peak: Autos <u>1086</u>	Off Peak: Autos <u>1643</u>
Med Trucks <u>15</u>	Med Trucks <u>15</u>	Med Trucks <u>23</u>
Hvy Trucks <u>37</u>	Hvy Trucks <u>37</u>	Hvy Trucks <u>55</u>
Buses <u>0</u>	Buses <u>0</u>	Buses <u>1</u>
Motorcycles <u>3</u>	Motorcycles <u>3</u>	Motorcycles <u>5</u>
Demand	Demand	Demand
Peak: Autos <u>1560</u>	Peak: Autos <u>2952</u>	Peak: Autos <u>2952</u>
Med Trucks <u>22</u>	Med Trucks <u>41</u>	Med Trucks <u>41</u>
Hvy Trucks <u>52</u>	Hvy Trucks <u>99</u>	Hvy Trucks <u>99</u>
Buses <u>0</u>	Buses <u>1</u>	Buses <u>1</u>
Motorcycles <u>5</u>	Motorcycles <u>9</u>	Motorcycles <u>9</u>
Off Peak: Autos <u>867</u>	Off Peak: Autos <u>1641</u>	Off Peak: Autos <u>1641</u>
Med Trucks <u>12</u>	Med Trucks <u>23</u>	Med Trucks <u>23</u>
Hvy Trucks <u>29</u>	Hvy Trucks <u>55</u>	Hvy Trucks <u>55</u>
Buses <u>0</u>	Buses <u>1</u>	Buses <u>1</u>
Motorcycles <u>3</u>	Motorcycles <u>5</u>	Motorcycles <u>5</u>

## TRAFFIC DATA FOR NOISE STUDIES

Project: US 41 Date: 9/13/2013  
 Work Program Item Seg. No.: 430056-1 Prepared By: American  
 Financial Project ID Number(s): \_\_\_\_\_  
 Federal Aid Number(s): \_\_\_\_\_  
 Segment Description: US 41 from Riverview Drive/Industrial Access Road to CR 676A Alternative: N/A  
(Madison Avenue/Pendola Point Road)

(Data sheets are to be filled out for every segment having a change in traffic parameters such as volumes, posted speeds, typical section, etc.)

NOTE: Modeled ADT is the LOS(C) volume referenced in the FDOT LOS tables or demand, whichever is less.

Existing Facility	No-Build (Design Year)	Build (Design Year)
Lanes: <u>4</u>	Lanes: <u>4</u>	Lanes: <u>6</u>
Year: <u>2013</u>	Year: <u>2040</u>	Year: <u>2040</u>
ADT: LOS (C) <u>35,500</u>	ADT: LOS (C) <u>35,500</u>	ADT: LOS (C) <u>53,700</u>
Demand <u>26,650</u>	Demand <u>47,200</u>	Demand <u>47,200</u>
Posted Spd: <u>55</u> mph <u>89</u> kmh	Posted Spd: <u>45</u> mph <u>72</u> kmh	Posted Spd: <u>45</u> mph <u>72</u> kmh
K= <u>9.00</u> %	K= <u>9.00</u> %	K= <u>9.00</u> %
D= <u>64.27</u> %	D= <u>64.27</u> %	D= <u>64.27</u> %
T= <u>9.0</u> % for 24 hrs.	T= <u>9.0</u> % for 24 hrs.	T= <u>9.0</u> % for 24 hrs.
T= <u>4.50</u> % Design hr	T= <u>4.50</u> % Design hr	T= <u>4.50</u> % Design hr
<u>1.33</u> % Medium Trucks DHV	<u>1.33</u> % Medium Trucks DHV	<u>1.33</u> % Medium Trucks DHV
<u>3.20</u> % Heavy Trucks DHV	<u>3.20</u> % Heavy Trucks DHV	<u>3.20</u> % Heavy Trucks DHV
<u>0.03</u> % Buses DHV	<u>0.03</u> % Buses DHV	<u>0.03</u> % Buses DHV
<u>0.30</u> % Motorcycles DHV	<u>0.30</u> % Motorcycles DHV	<u>0.30</u> % Motorcycles DHV

STAMINA/TNM INPUT					
The following are spreadsheet calculations based on the input above - do not enter data below this line					
Existing Facility Model:	Demand	No-Build (Design Year) Model:	LOS (C)	Build (Design Year) Model:	Demand
LOS (C)		LOS (C)		LOS (C)	
Peak:	Autos <u>1954</u>	Peak:	Autos <u>1954</u>	Peak:	Autos <u>2955</u>
	Med Trucks <u>27</u>		Med Trucks <u>27</u>		Med Trucks <u>41</u>
	Hvy Trucks <u>66</u>		Hvy Trucks <u>66</u>		Hvy Trucks <u>99</u>
	Buses <u>1</u>		Buses <u>1</u>		Buses <u>1</u>
	Motorcycles <u>6</u>		Motorcycles <u>6</u>		Motorcycles <u>9</u>
Off Peak:	Autos <u>1086</u>	Off Peak:	Autos <u>1086</u>	Off Peak:	Autos <u>1643</u>
	Med Trucks <u>15</u>		Med Trucks <u>15</u>		Med Trucks <u>23</u>
	Hvy Trucks <u>37</u>		Hvy Trucks <u>37</u>		Hvy Trucks <u>55</u>
	Buses <u>0</u>		Buses <u>0</u>		Buses <u>1</u>
	Motorcycles <u>3</u>		Motorcycles <u>3</u>		Motorcycles <u>5</u>
Demand		Demand		Demand	
Peak:	Autos <u>1467</u>	Peak:	Autos <u>2598</u>	Peak:	Autos <u>2598</u>
	Med Trucks <u>21</u>		Med Trucks <u>36</u>		Med Trucks <u>36</u>
	Hvy Trucks <u>49</u>		Hvy Trucks <u>87</u>		Hvy Trucks <u>87</u>
	Buses <u>0</u>		Buses <u>1</u>		Buses <u>1</u>
	Motorcycles <u>5</u>		Motorcycles <u>8</u>		Motorcycles <u>8</u>
Off Peak:	Autos <u>815</u>	Off Peak:	Autos <u>1444</u>	Off Peak:	Autos <u>1444</u>
	Med Trucks <u>11</u>		Med Trucks <u>20</u>		Med Trucks <u>20</u>
	Hvy Trucks <u>27</u>		Hvy Trucks <u>49</u>		Hvy Trucks <u>49</u>
	Buses <u>0</u>		Buses <u>0</u>		Buses <u>0</u>
	Motorcycles <u>3</u>		Motorcycles <u>5</u>		Motorcycles <u>5</u>

### TRAFFIC DATA FOR NOISE STUDIES

Project: US 41 Date: 9/13/2013  
 Work Program Item Seg. No.: 430056-1 Prepared By: American  
 Financial Project ID Number(s): \_\_\_\_\_  
 Federal Aid Number(s): \_\_\_\_\_  
 Segment Description: US 41 from CR 676A (Madison Avenue/Pendola Point Road) to Port Sutton Road Alternative: N/A

(Data sheets are to be filled out for every segment having a change in traffic parameters such as volumes, posted speeds, typical section, etc.)

NOTE: Modeled ADT is the LOS(C) volume referenced in the FDOT LOS tables or demand, whichever is less.

Existing Facility	No-Build (Design Year)	Build (Design Year)
Lanes: <u>4</u>	Lanes: <u>4</u>	Lanes: <u>6</u>
Year: <u>2013</u>	Year: <u>2040</u>	Year: <u>2040</u>
ADT: <u>35,500</u>	ADT: <u>35,500</u>	ADT: <u>53,700</u>
LOS (C) <u>35,500</u>	LOS (C) <u>35,500</u>	LOS (C) <u>53,700</u>
Demand <u>32,350</u>	Demand <u>57,625</u>	Demand <u>57,625</u>
Posted Spd: <u>50</u> mph <u>80</u> kmh	Posted Spd: <u>45</u> mph <u>72</u> kmh	Posted Spd: <u>45</u> mph <u>72</u> kmh
K= <u>9.00</u> %	K= <u>9.00</u> %	K= <u>9.00</u> %
D= <u>64.27</u> %	D= <u>64.27</u> %	D= <u>64.27</u> %
T= <u>11.0</u> % for 24 hrs.	T= <u>11.0</u> % for 24 hrs.	T= <u>11.0</u> % for 24 hrs.
T= <u>5.50</u> % Design hr	T= <u>5.50</u> % Design hr	T= <u>5.50</u> % Design hr
<u>1.91</u> % Medium Trucks DHV	<u>1.91</u> % Medium Trucks DHV	<u>1.91</u> % Medium Trucks DHV
<u>3.64</u> % Heavy Trucks DHV	<u>3.64</u> % Heavy Trucks DHV	<u>3.64</u> % Heavy Trucks DHV
<u>0.05</u> % Buses DHV	<u>0.05</u> % Buses DHV	<u>0.05</u> % Buses DHV
<u>0.23</u> % Motorcycles DHV	<u>0.23</u> % Motorcycles DHV	<u>0.23</u> % Motorcycles DHV

STAMINA/TNM INPUT					
The following are spreadsheet calculations based on the input above - do not enter data below this line					
Existing Facility Model:	Demand	No-Build (Design Year) Model:	LOS (C)	Build (Design Year) Model:	LOS (C)
LOS (C)		LOS (C)		LOS (C)	
Peak:	Autos <u>1934</u>	Peak:	Autos <u>1934</u>	Peak:	Autos <u>2925</u>
	Med Trucks <u>39</u>		Med Trucks <u>39</u>		Med Trucks <u>59</u>
	Hvy Trucks <u>75</u>		Hvy Trucks <u>75</u>		Hvy Trucks <u>113</u>
	Buses <u>1</u>		Buses <u>1</u>		Buses <u>2</u>
	Motorcycles <u>5</u>		Motorcycles <u>5</u>		Motorcycles <u>7</u>
Off Peak:	Autos <u>1075</u>	Off Peak:	Autos <u>1075</u>	Off Peak:	Autos <u>1626</u>
	Med Trucks <u>22</u>		Med Trucks <u>22</u>		Med Trucks <u>33</u>
	Hvy Trucks <u>42</u>		Hvy Trucks <u>42</u>		Hvy Trucks <u>63</u>
	Buses <u>1</u>		Buses <u>1</u>		Buses <u>1</u>
	Motorcycles <u>3</u>		Motorcycles <u>3</u>		Motorcycles <u>4</u>
Demand		Demand		Demand	
Peak:	Autos <u>1762</u>	Peak:	Autos <u>3139</u>	Peak:	Autos <u>3139</u>
	Med Trucks <u>36</u>		Med Trucks <u>64</u>		Med Trucks <u>64</u>
	Hvy Trucks <u>68</u>		Hvy Trucks <u>121</u>		Hvy Trucks <u>121</u>
	Buses <u>1</u>		Buses <u>2</u>		Buses <u>2</u>
	Motorcycles <u>4</u>		Motorcycles <u>8</u>		Motorcycles <u>8</u>
Off Peak:	Autos <u>980</u>	Off Peak:	Autos <u>1745</u>	Off Peak:	Autos <u>1745</u>
	Med Trucks <u>20</u>		Med Trucks <u>35</u>		Med Trucks <u>35</u>
	Hvy Trucks <u>38</u>		Hvy Trucks <u>67</u>		Hvy Trucks <u>67</u>
	Buses <u>1</u>		Buses <u>1</u>		Buses <u>1</u>
	Motorcycles <u>2</u>		Motorcycles <u>4</u>		Motorcycles <u>4</u>

### TRAFFIC DATA FOR NOISE STUDIES

Project: US 41 Date: 9/13/2013  
 Work Program Item Seg. No.: 430056-1 Prepared By: American  
 Financial Project ID Number(s): \_\_\_\_\_  
 Federal Aid Number(s): \_\_\_\_\_  
 Segment Description: US 41 from Port Sutton Road to South of SR 676 (Causeway Boulevard) Alternative: N/A

(Data sheets are to be filled out for every segment having a change in traffic parameters such as volumes, posted speeds, typical section, etc.)

NOTE: Modeled ADT is the LOS(C) volume referenced in the FDOT LOS tables or demand, whichever is less.

Existing Facility	No-Build (Design Year)	Build (Design Year)
Lanes: <u>6</u>	Lanes: <u>6</u>	Lanes: <u>6</u>
Year: <u>2013</u>	Year: <u>2040</u>	Year: <u>2040</u>
ADT: <u>53,700</u>	ADT: <u>53,700</u>	ADT: <u>53,700</u>
LOS (C) <u>53,700</u>	LOS (C) <u>53,700</u>	LOS (C) <u>53,700</u>
Demand <u>36,400</u>	Demand <u>68,550</u>	Demand <u>68,550</u>
Posted Spd: <u>50</u> mph <u>80</u> kmh	Posted Spd: <u>45</u> mph <u>72</u> kmh	Posted Spd: <u>45</u> mph <u>72</u> kmh
K= <u>9.00</u> %	K= <u>9.00</u> %	K= <u>9.00</u> %
D= <u>64.27</u> %	D= <u>64.27</u> %	D= <u>64.27</u> %
T= <u>11.0</u> % for 24 hrs.	T= <u>11.0</u> % for 24 hrs.	T= <u>11.0</u> % for 24 hrs.
T= <u>5.50</u> % Design hr	T= <u>5.50</u> % Design hr	T= <u>5.50</u> % Design hr
<u>1.91</u> % Medium Trucks DHV	<u>1.91</u> % Medium Trucks DHV	<u>1.91</u> % Medium Trucks DHV
<u>3.64</u> % Heavy Trucks DHV	<u>3.64</u> % Heavy Trucks DHV	<u>3.64</u> % Heavy Trucks DHV
<u>0.05</u> % Buses DHV	<u>0.05</u> % Buses DHV	<u>0.05</u> % Buses DHV
<u>0.23</u> % Motorcycles DHV	<u>0.23</u> % Motorcycles DHV	<u>0.23</u> % Motorcycles DHV

STAMINA/TNM INPUT					
The following are spreadsheet calculations based on the input above - do not enter data below this line					
Existing Facility Model:	Demand	No-Build (Design Year) Model:	LOS (C)	Build (Design Year) Model:	LOS (C)
LOS (C)		LOS (C)		LOS (C)	
Peak:	Autos <u>2925</u>	Peak:	Autos <u>2925</u>	Peak:	Autos <u>2925</u>
	Med Trucks <u>59</u>		Med Trucks <u>59</u>		Med Trucks <u>59</u>
	Hvy Trucks <u>113</u>		Hvy Trucks <u>113</u>		Hvy Trucks <u>113</u>
	Buses <u>2</u>		Buses <u>2</u>		Buses <u>2</u>
	Motorcycles <u>7</u>		Motorcycles <u>7</u>		Motorcycles <u>7</u>
Off Peak:	Autos <u>1626</u>	Off Peak:	Autos <u>1626</u>	Off Peak:	Autos <u>1626</u>
	Med Trucks <u>33</u>		Med Trucks <u>33</u>		Med Trucks <u>33</u>
	Hvy Trucks <u>63</u>		Hvy Trucks <u>63</u>		Hvy Trucks <u>63</u>
	Buses <u>1</u>		Buses <u>1</u>		Buses <u>1</u>
	Motorcycles <u>4</u>		Motorcycles <u>4</u>		Motorcycles <u>4</u>
Demand		Demand		Demand	
Peak:	Autos <u>1983</u>	Peak:	Autos <u>3734</u>	Peak:	Autos <u>3734</u>
	Med Trucks <u>40</u>		Med Trucks <u>76</u>		Med Trucks <u>76</u>
	Hvy Trucks <u>77</u>		Hvy Trucks <u>144</u>		Hvy Trucks <u>144</u>
	Buses <u>1</u>		Buses <u>2</u>		Buses <u>2</u>
	Motorcycles <u>5</u>		Motorcycles <u>9</u>		Motorcycles <u>9</u>
Off Peak:	Autos <u>1102</u>	Off Peak:	Autos <u>2076</u>	Off Peak:	Autos <u>2076</u>
	Med Trucks <u>22</u>		Med Trucks <u>42</u>		Med Trucks <u>42</u>
	Hvy Trucks <u>43</u>		Hvy Trucks <u>80</u>		Hvy Trucks <u>80</u>
	Buses <u>1</u>		Buses <u>1</u>		Buses <u>1</u>
	Motorcycles <u>3</u>		Motorcycles <u>5</u>		Motorcycles <u>5</u>

Florida Department of Transportation  
Annual Vehicle Classification Report - Report Type: ALL  
Count Year 2012

County: 10 - HILLSBOROUGH

Site Co Sec Sub MilePost Description  
5346 10060000 14.400 SR 45/US 41, NORTH OF CR 672/BIG BEND ROAD

Func. Class: 14 - Urban Other Principal Arterial

Survey Type: Portable Duration: 2 Days

Class	Description	Annual Average Daily		Summary Daily Statistics	
		Volume	%	Daily	Design Hour
Class 01	MOTORCYCLES	86	0.40	24T&B = 8.96%	DHT = 4.48%
Class 02	CARS	14044	65.32	24T = 8.82%	
Class 03	PICK-UPS AND VANS	5444	25.32	24H = 6.11%	DH3 = 3.06%
Class 04	BUSES	30	0.14	24M = 2.85%	DH2 = 1.42%
Class 05	2-AXLE, SINGLE UNIT TRUCKS	583	2.71		
Class 06	3-AXLE, SINGLE UNIT TRUCKS	316	1.47		
Class 07	4-AXLE, SINGLE UNIT TRUCKS	87	0.40		
Class 08	2-AXL TRCTR W/ 1 OR 2-AXL TRLR, 3-AXL TRCTR W/ 1-A	339	1.58		
Class 09	3-AXLE TRACTOR W/ 2-AXLE TRLR	532	2.47		
Class 10	3-AXLE TRACTOR W/ 3-AXLE TRLR	39	0.18		
Class 11	5-AXLE MULTI-TRLR	0	0.00		
Class 12	6-AXLE MULTI-TRLR	0	0.00		
Class 13	ANY 7 OR MORE AXLE	2	0.01		
Class 14	NOT USED	0	0.00		
Class 15	OTHER	0	0.00		
		-----	-----		
		21500	100.00		

Site Co Sec Sub MilePost Description  
5347 10090000 6.900 SR 574/MLK BLVD, W OF VALRICO

Func. Class: 14 - Urban Other Principal Arterial

Survey Type: Portable Duration: 2 Days

Class	Description	Annual Average Daily		Summary Daily Statistics	
		Volume	%	Daily	Design Hour
Class 01	MOTORCYCLES	99	0.79	24T&B = 7.61%	DHT = 3.80%
Class 02	CARS	8345	66.23	24T = 7.23%	
Class 03	PICK-UPS AND VANS	3166	25.12	24H = 3.68%	DH3 = 1.84%
Class 04	BUSES	48	0.38	24M = 3.92%	DH2 = 1.96%
Class 05	2-AXLE, SINGLE UNIT TRUCKS	447	3.55		
Class 06	3-AXLE, SINGLE UNIT TRUCKS	109	0.87		
Class 07	4-AXLE, SINGLE UNIT TRUCKS	17	0.14		
Class 08	2-AXL TRCTR W/ 1 OR 2-AXL TRLR, 3-AXL TRCTR W/ 1-A	143	1.13		
Class 09	3-AXLE TRACTOR W/ 2-AXLE TRLR	183	1.46		
Class 10	3-AXLE TRACTOR W/ 3-AXLE TRLR	9	0.07		
Class 11	5-AXLE MULTI-TRLR	2	0.02		
Class 12	6-AXLE MULTI-TRLR	0	0.00		
Class 13	ANY 7 OR MORE AXLE	0	0.00		
Class 14	NOT USED	0	0.00		
Class 15	OTHER	31	0.25		
		-----	-----		
		12600	100.00		

Classes: Passenger Vehicles 01-03, Truck & Buses 04-13, Trucks 05-13, Medium Trucks 04-05, Heavy Trucks 06-13

Florida Department of Transportation  
Annual Vehicle Classification Report - Report Type: ALL  
Count Year 2012

County: 10 - HILLSBOROUGH

Site Co Sec Sub MilePost Description  
5258 10060000 21.879 SR 45/US 41/S 50TH ST, SOUTH OF CR 676A/MADISON AV

Func. Class: 14 - Urban Other Principal Arterial

Survey Type: Portable Duration: 2 Days

Class	Description	Annual Average Daily		Summary Daily Statistics	
		Volume	%	Daily	Design Hour
Class 01	MOTORCYCLES	150	0.60	24T&B = 10.14%	DHT = 5.07%
Class 02	CARS	16103	64.41	24T = 10.08%	
Class 03	PICK-UPS AND VANS	6211	24.85	24H = 7.14%	DH3 = 3.57%
Class 04	BUSES	15	0.06	24M = 3.00%	DH2 = 1.50%
Class 05	2-AXLE, SINGLE UNIT TRUCKS	735	2.94		
Class 06	3-AXLE, SINGLE UNIT TRUCKS	463	1.85		
Class 07	4-AXLE, SINGLE UNIT TRUCKS	166	0.66		
Class 08	2-AXL TRCTR W/ 1 OR 2-AXL TRLR, 3-AXL TRCTR W/ 1-A	394	1.58		
Class 09	3-AXLE TRACTOR W/ 2-AXLE TRLR	705	2.82		
Class 10	3-AXLE TRACTOR W/ 3-AXLE TRLR	48	0.19		
Class 11	5-AXLE MULTI-TRLR	3	0.01		
Class 12	6-AXLE MULTI-TRLR	0	0.00		
Class 13	ANY 7 OR MORE AXLE	6	0.02		
Class 14	NOT USED	0	0.00		
Class 15	OTHER	0	0.00		
		-----	-----		
		25000	100.00		

Site Co Sec Sub MilePost Description  
5259 10010000 20.593 SR 43/US 301, S OF SR 676/CAUSEWAY BLVD

Func. Class: 14 - Urban Other Principal Arterial

Survey Type: Portable Duration: 2 Days

Class	Description	Annual Average Daily		Summary Daily Statistics	
		Volume	%	Daily	Design Hour
Class 01	MOTORCYCLES	289	0.75	24T&B = 6.65%	DHT = 3.32%
Class 02	CARS	27815	72.25	24T = 6.39%	
Class 03	PICK-UPS AND VANS	7837	20.36	24H = 3.77%	DH3 = 1.88%
Class 04	BUSES	100	0.26	24M = 2.88%	DH2 = 1.44%
Class 05	2-AXLE, SINGLE UNIT TRUCKS	1009	2.62		
Class 06	3-AXLE, SINGLE UNIT TRUCKS	212	0.55		
Class 07	4-AXLE, SINGLE UNIT TRUCKS	23	0.06		
Class 08	2-AXL TRCTR W/ 1 OR 2-AXL TRLR, 3-AXL TRCTR W/ 1-A	413	1.07		
Class 09	3-AXLE TRACTOR W/ 2-AXLE TRLR	734	1.91		
Class 10	3-AXLE TRACTOR W/ 3-AXLE TRLR	18	0.05		
Class 11	5-AXLE MULTI-TRLR	13	0.03		
Class 12	6-AXLE MULTI-TRLR	6	0.02		
Class 13	ANY 7 OR MORE AXLE	30	0.08		
Class 14	NOT USED	0	0.00		
Class 15	OTHER	0	0.00		
		-----	-----		
		38500	100.00		

Classes: Passenger Vehicles 01-03, Truck & Buses 04-13, Trucks 05-13, Medium Trucks 04-05, Heavy Trucks 06-13



Florida Department of Transportation  
Annual Vehicle Classification Report - Report Type: ALL  
Count Year 2012

County: 10 - HILLSBOROUGH

Site Co Sec Sub MilePost Description  
0193 10030000 16.775 SR 600/US 92, E OF BRANCH FORBES RD

Func. Class: 14 - Urban Other Principal Arterial

Survey Type: Portable Duration: 2 Days

Class	Annual Average Daily		Summary Daily Statistics	
	Volume	%	Daily	Design Hour
Class 01 MOTORCYCLES	41	0.32	24T&B = 10.56%	DHT = 5.28%
Class 02 CARS	8061	63.47	24T = 8.15%	
Class 03 PICK-UPS AND VANS	3258	25.65	24H = 3.81%	DH3 = 1.90%
Class 04 BUSES	306	2.41	24M = 6.75%	DH2 = 3.38%
Class 05 2-AXLE, SINGLE UNIT TRUCKS	551	4.34		
Class 06 3-AXLE, SINGLE UNIT TRUCKS	85	0.67		
Class 07 4-AXLE, SINGLE UNIT TRUCKS	16	0.12		
Class 08 2-AXL TRCTR W/ 1 OR 2-AXL TRLR, 3-AXL TRCTR W/ 1-A	91	0.71		
Class 09 3-AXLE TRACTOR W/ 2-AXLE TRLR	279	2.20		
Class 10 3-AXLE TRACTOR W/ 3-AXLE TRLR	11	0.09		
Class 11 5-AXLE MULTI-TRLR	0	0.00		
Class 12 6-AXLE MULTI-TRLR	1	0.01		
Class 13 ANY 7 OR MORE AXLE	0	0.00		
Class 14 NOT USED	0	0.00		
Class 15 OTHER	0	0.00		
	-----	-----		
	12700	100.00		

Site Co Sec Sub MilePost Description  
0373 10060000 23.045 US-41, 0.5 MI S OF SR-676/CAUSEWAY BLVD, TAMPA, HI

Func. Class: 14 - Urban Other Principal Arterial

Survey Type: Telemetered Duration: 353 Days

Class	Annual Average Daily		Summary Daily Statistics	
	Volume	%	Daily	Design Hour
Class 01 MOTORCYCLES	124	0.45	24T&B = 10.27%	DHT = 5.14%
Class 02 CARS	16779	60.80	24T = 10.18%	
Class 03 PICK-UPS AND VANS	7158	25.94	24H = 6.74%	DH3 = 3.37%
Class 04 BUSES	25	0.09	24M = 3.53%	DH2 = 1.77%
Class 05 2-AXLE, SINGLE UNIT TRUCKS	950	3.44		
Class 06 3-AXLE, SINGLE UNIT TRUCKS	399	1.45		
Class 07 4-AXLE, SINGLE UNIT TRUCKS	68	0.25		
Class 08 2-AXL TRCTR W/ 1 OR 2-AXL TRLR, 3-AXL TRCTR W/ 1-A	368	1.33		
Class 09 3-AXLE TRACTOR W/ 2-AXLE TRLR	981	3.56		
Class 10 3-AXLE TRACTOR W/ 3-AXLE TRLR	30	0.11		
Class 11 5-AXLE MULTI-TRLR	1	0.00		
Class 12 6-AXLE MULTI-TRLR	1	0.00		
Class 13 ANY 7 OR MORE AXLE	11	0.04		
Class 14 NOT USED	0	0.00		
Class 15 OTHER	703	2.55		
	-----	-----		
	27598	100.00		

Classes: Passenger Vehicles 01-03, Truck & Buses 04-13, Trucks 05-13, Medium Trucks 04-05, Heavy Trucks 06-13

# Appendix K

## FDOT Comment-Responses and Meeting Minutes

September 16, 2013

Waddah Farah  
Florida Department of Transportation  
District 7  
11201 N. McKinley Drive  
Tampa, Florida 33612

Re: US 41 PD&E Study from Kracker Avenue to South of SR 676 (Causeway Boulevard)  
FPN: 430056-1-22-01  
Draft Design Traffic Technical Memorandum  
Response to FDOT Comments (08-14-2013)

Dear Mr. Farah:

American has reviewed the FDOT comments for the Draft Design Traffic Technical Memorandum (DTTM) received on August 14, 2013 and we offer the following responses:

Comment 1: Page 5-1 - Please explain why the proposed design speed should be 45 mph between Symmes Road and Riverview Drive/Industrial Access Road where the rest of the corridor has a proposed design speed of 50 mph. Currently through this area the existing speed limit varies between 50 and 55 mph.

**Response:** *Proposed design speed is 45 mph along US 41 between Symmes Road and Riverview Drive/Industrial Access Road whereas the rest of the corridor has a design speed of 50 mph as the transition to the urban section under the proposed typical section along US 41 occurs north of the Bullfrog Creek which is immediately north of Symmes Road. Also, the right-of-way is constrained along US 41 within this section. North of Riverview Drive/Industrial Access Road, the right-of-way widens out and US 41 transitions back to a suburban section with higher design speed of 50 mph. This will be added on page 5-1 last paragraph of the Draft DTTM.*

Comment 2: Figure 5-1 - Many of the major side streets shows extensive intersection improvements such as multiple left and right turn lanes from the west approaches, and also triple and double lefts going from US 41 to these major side streets.

- a. It is noted that these improvements are necessary in order to make the intersection operate at an acceptable level of service, but does not allow for every approach to operate at an acceptable level of service.

- b. The side street improvements will cause extensive work on the side street. What are Hillsborough County's plans for these roads? Are these side street improvements going to be proposed as part of the PD&E study or shown as work done by others?

**Response:** (a) *Comment noted.*

(b) *Communication with Hillsborough County is underway to determine the future plans for the County so these improvements will be implemented by the County. These will be resolved as part of the Engineering Report.*

Comment 3: Figure 5-1 - Please note if the build proposed lane geometry is different than the recommended alternative that is developed as the PD&E progresses, then the Design Traffic Technical Memorandum will need to also show/analyze the recommended alternative. Therefore, if the side street is minor, it's unreasonable to assume triple lefts just to make the approach and/or intersection meet the LOS standard. Otherwise, we will end up purchasing R/W that we will never use.

**Response:** *This comment will be addressed in the Engineering Report after coordination between Hillsborough County and the Department. Analysis for the recommended alternative will be included in the Engineering Report. Cost estimates will be coordinated with the different responsible agencies related to the right-of-way.*

Comment 4: Appendix I – Please include existing turn lane lengths to note what the existing conditions are.

**Response:** *The existing turn lane lengths will be included in Appendix I.*

Comment 5: It is difficult to conceive of some of these fairly minor side streets needing triple left turn and triple right turn lanes (Figure 5-1). Would these intersections fail that bad with just dual left or right turn lanes? The segment LOS seems to indicate that the through capacity in the build scenario is great even in the 2040 design year, indicating that there may be surplus capacity on the mainline.

**Response:** *The study intersections of US 41 at Gibsonton Drive/Alice Avenue, Riverview Drive/Industrial Access Road and CR 676A (Madison Avenue)/Pendola Point Road will not operate at an acceptable level of service without triple left turn or triple right turn lanes due to the heavy traffic volumes in the future years. Analysis with dual left or right turn lanes will be provided and added in the appendices to the report. If the recommended alternative developed as the PD&E progresses comprises of dual left and*

***dual right turn lanes, analysis for the recommended alternative will be included as a part of the Engineering Report. Comment noted about the surplus capacity on the main line in the 2040 design year.***

Comment 6: Rather than create another 6-lane arterial, would it make sense to consider the North Street – South 78<sup>th</sup> Street corridor (including a new bridge over the Alafia River) for a new corridor? Shouldn't something like this be a part of the PD&E process.

***Response: The future traffic projections along the study corridor of US 41 require widening of the existing facility to a six-lane arterial. Considering a new corridor is not part of this study.***

If you have any questions, please feel free to contact me at 813-435-2565 or Arpita Guha at 813-435-2618.

Sincerely,  
***American Consulting Engineers of Florida, LLC***

  
Akram Hussein, P.E., PTOE

cc: Manny Santos, FDOT-D7  
Kirk Bogen, FDOT-D7  
Peter Maass, FDOT-D7  
David Winkle, FDOT-D7  
Peter Hsu, FDOT-D7  
Rick Adair, FDOT-D7  
Jeff Novotny, American  
Arpita Guha, American  
Larry Weatherby, American

September 16, 2013

Mark Chianese  
Florida Department of Transportation  
District 7  
11201 N. McKinley Drive  
Tampa, Florida 33612

Re: US 41 PD&E Study from Kracker Avenue to South of SR 676 (Causeway Boulevard)  
FPN: 430056-1-22-01  
Draft Traffic Technical Memorandum  
Response to FDOT Comments (8-25-2013)

Dear Mr. Chianese:

American has reviewed the FDOT comments for the Draft Design Traffic Technical Memorandum (DTTM) received on August 26, 2013 and we offer the following responses:

Comment 1: Please consider adding a certification page right after the report's cover sheet.

**Response:** *A certification page will be added right after the report's cover sheet.*

Comment 2: Consider adding a Glossary of Terms to the report.

**Response:** *Glossary of Terms will be added to the report.*

Comment 3: Page 1-1 (1<sup>st</sup> paragraph): Please consider using capital "D" instead of lower case "d" for the word "determine" after colon (:).

**Response:** *Comment will be addressed in the report.*

Comment 4: Page 1-1 (1<sup>st</sup> paragraph): Please consider revising "consider agency and public comments" as follows: "Consider and incorporate applicable agency and public comments."

**Response:** *Comment will be addressed in the report.*

Comment 5: Page 1-1 (2<sup>nd</sup> paragraph): Please consider deleting either "projected" or "future" from the last sentence since they are redundant.

**Response:** *Comment will be addressed in the report.*

Comment 6: Page 1-1 (2<sup>nd</sup> sentence of 3<sup>rd</sup> paragraph): Please consider adding the FDOT reference document to the following sentence: “The acceptable level of service (LOS) standard for the study corridor of US 41 in the urbanized area within the project limits is ‘LOS D’ per FDOT.”

**Response:** *The sentence in the comment will be revised to:  
“The acceptable level of service (LOS) standard for the study corridor of US 41 in the urbanized area within the project limits is ‘LOS D’ per FDOT based on the “Planning Boundaries for LOS Standards Hillsborough County”.”*

Comment 7: Page 1-1 (3<sup>rd</sup> sentence of 3<sup>rd</sup> paragraph): Please consider replacing “the” in the “both the peak periods” with “both AM and PM peak periods.”

**Response:** *Comment will be addressed in the report.*

Comment 8: Page 1-1 (3<sup>rd</sup> sentence of 3<sup>rd</sup> paragraph): Please consider revising “existing analysis” to “existing intersection analysis” for enhance differentiation since the subsequent sentence refers to the “existing roadway segment analysis.”

**Response:** *Comment will be addressed in the report.*

Comment 9: Page 1-2 (3<sup>rd</sup> paragraph): Please consider clarifying the following sentence: “The operational analysis for build conditions was conducted to assess the traffic operational impact of widening US 41 improving capacity and identify required turn lanes at intersections to operate at an acceptable level of service.”

**Response:** *The sentence in the comment will be revised to:  
“The operational analysis for build conditions was conducted to assess the impact of widening US 41 in improving capacity and traffic operation along the study corridor and also, identify required turn lanes at intersections to operate at an acceptable level of service.”*

Comment 10: Page 1-2 (3<sup>rd</sup> paragraph): Please consider adding “and” after pedestrian ramps in the following term: “Pedestrian crosswalks, pedestrian ramps, pedestrian signals”

**Response:** *Comment will be addressed in the report.*

Comment 11: Page 1-2 (3<sup>rd</sup> paragraph): Please consider using “crosswalks” instead of “crosswalk” in the following sentence: “Also, crosswalk will be provided at all un-signalized intersections per FDOT- District Seven standards.”

**Response:** *Comment will be addressed in the report.*

Comment 12: Page 2-1 (1<sup>st</sup> paragraph): Please note that the reference to “current 4-lane facility: does not match “US 41 currently has a five-lane divided urban typical section...and six-lane divided urban typical section” on Page 2-4 (1<sup>st</sup> paragraph under Section 2.4).

**Response:** *The sentence in the comment will be revised to:  
“The proposed improvement is anticipated to expand the current predominantly 4-lane and 5-lane facility to 6-lanes.”*

Comment 13: Page 2-3 (1<sup>st</sup> paragraph): Please consider naming the port referenced in the following sentence: “US 41 provide connectivity to the port through three accesses at Riverview Drive, Madison Avenue and Port Sutton Road.”

**Response:** *The sentence in the comment will be revised to:  
“US 41 provide connectivity to the Port of Tampa through three accesses at Riverview Drive, Madison Avenue and Port Sutton Road.”*

Comment 14: Page 2-3 (3<sup>rd</sup> paragraph): To avoid duplication/redundancy, please consider deleting “Socioeconomic growth projections from” from the following sentence: “Socioeconomic growth projections from the Hillsborough County City-County Planning Commission’s 2035 Long Range Transportation Plan Socioeconomic Projections estimate an employment increase of...”

**Response:** *Comment will be addressed in the report.*

Comment 15: Page 2-3 (last paragraph): To avoid duplication/redundancy, please consider replacing “operational improvements” with “roadway improvements” in the 1<sup>st</sup> sentence of this paragraph.

**Response:** *Comment will be addressed in the report.*

Comment 16: Page 2-5 (1<sup>st</sup> paragraph): Please consider defining which segments along the improved corridor will have design speeds of 45 mph and 50 mph, respectively, as well as associated basis.

**Response:** *The sentence in the comment will be revised to:  
“The design speed will be reduced to 45 mph from Symmes Road to Riverview Drive/Industrial Access Road and 50 mph over the remaining roadway segment within the study corridor as a part of the widening project.”*

Comment 17: Page 3-5 (1<sup>st</sup> sentence under Section 3.): Please consider replacing “includes” with “include.”

**Response:** *Comment will be addressed in the report.*

Comment 18: Page 3-16 (sentence before last): Please consider using “crosswalks” instead of “crosswalk” in the following sentence: “Also, crosswalk will be provided at all un-signalized intersections per FDOT standards.”



**Response:** *Comment will be addressed in the report.*

Comment 19: Page 4-1 (Section 4): Please consider replacing “will be developed” with “were developed.”

**Response:** *Comment will be addressed in the report.*

Comment 20: Page 4-1 (Section 4.1, last sentence of 1<sup>st</sup> paragraph): Please consider using “were” instead of “was” since reference is to both “process and results.”

**Response:** *Comment will be addressed in the report.*

Comment 21: Page 5-1 (section 5): Please consider adding the word “signalized” before “intersections” in the following sentence: “SYNCHRO Version 7.0 (Build 759) was used as the analysis tool for the intersections and segments within the study limits.”

**Response:** *Comment will be addressed in the report.*

Comment 22: Page 5-1 (section 5): Please consider rewording the following paragraph to address its contradiction: “The proposed build typical section along US 41 within the study limits comprises of six-lane divided roadway with 50 mph design speed with the exception of the segment between Symmes Road and Riverview Drive/Industrial Access Road where the proposed design speed is 45 mph. Therefore, in the build analysis, speed limit of 45 mph has been used along US 41 within the project limits with the exception of the segment between Symmes Road and Riverview Drive/Industrial Access Road where a speed limit of 40 mph has been used.”

**Response:** *This section states about the design speed and the posted speed limits. Last paragraph on page 5-1 will not be revised as this section does not have any contradiction.*

Comment 23: Table 5-1: Please consider deleting the word “warrant” from the last column. Also please consider replacing “not available” with “not warranted” in the same column.

**Response:** *The word “warrant” will be deleted from the last column of Table 5-1. However, “not available” in the last column of the same table will be maintained as it is considered to be more appropriate.*

Comment 24: Table 5-14: Considerations should be given to use of (at least) dual left turn lanes in the northbound and southbound directions predominately and westbound directions in some cases for many signalized intersections (e.g., Gibsonton Dr., Industrial Access, Madison Ave, etc.) that have significantly long recommended turn lane lengths. This consideration would help reduce traffic delays and associated queues and improve intersection level of service significantly. Though receiving lanes of adequate lengths may be required to accommodate this consideration in some cases, such investment will be of significant value in improving the levels of service of these intersections.

**Response:** *Table 5-14 reports the turn lane lengths per lane. It should be considered that multiple turn lanes have been considered at the different locations as required from traffic operational analysis. This can be more elaborately found in Appendix I of the Draft Design Traffic Technical Memorandum. Many of the left-turn storage lengths are significantly long as reported in Table 5-14 as they are based on through queue lengths when they exceed storage length for turn lanes.*

Comment 25: Page 6-2 (last paragraph): Please consider adding “and” after pedestrian ramps in the following term: “Pedestrian crosswalks, pedestrian ramps, pedestrian signals”

**Response:** *Comment will be addressed in the report.*

Comment 26: Page 6-1 (last paragraph): Please consider using “crosswalks” instead of “crosswalk” in the following sentence: “Also, crosswalk will be provided at all un-signalized intersections per FDOT- District Seven standards.”

**Response:** *Comment will be addressed in the report.*

If you have any questions, please feel free to contact me at 813-435-2565 or Arpita Guha at 813-435-2618.

Sincerely,  
*American Consulting Engineers of Florida, LLC*



Akram Hussein, P.E., PTOE

cc: Manny Santos, FDOT-D7  
Kirk Bogen, FDOT-D7  
Waddah Farah, FDOT-D7  
Peter Maass, FDOT-D7  
David Winkle, FDOT-D7  
Peter Hsu, FDOT-D7  
Rick Adair, FDOT-D7  
Ali Gord, Gord & Associates, Inc.  
Jeff Novotny, American  
Arpita Guha, American  
Larry Weatherby, American

## MEETING MINUTES

**Meeting Date:** October 31, 2013      **Date Issued:** November 6, 2013  
**Location:** Hillsborough County Offices at the County Center in Downtown Tampa  
**Project Name:** US 41 PD&E Study – WPI Segment #430056 1  
**Purpose:** To Review Recommended Intersection Improvements with County Staff, etc.  
**Notes by:** Larry Weatherby      **American Project #:** 5127041  
**Copies to:** Attendees and Rick Adair at FDOT (GEC)

<u>Attendees</u>	<u>Representing</u>	<u>Phone</u>	<u>E-mail</u>
Robert (Bob) Campbell	Hills. Co. PW - Traffic	813.272.5170	Campbellr@hillsboroughcounty.org
Roy Mazur	Hills. County Development Services	813.276.8643	Mazurr@hillsboroughcounty.org
Charles E. White	Hills. Co. Transportation Review Mgr.	813.307.4513	Whitece@hillsboroughcounty.org
John Patrick	Hills. Co.	813.276.8428	Patrickj@hillsboroughcounty.org
Mike Williams	Hills. Co. PW-Engr. & Environment	813.307.1851	Williamsm@hillsboroughcounty.org
Jeff Novotny	American Consulting Prof. (for FDOT)	813.435.2646	jnovotny@acp-fl.com
Arpita Guha	American Consulting Prof. (for FDOT)	813.435.2618	aguha@acp-fl.com
Larry Weatherby	American Consulting Prof. (for FDOT)	813.435.2637	lweatherby@acp-fl.com

The following notes reflect our understanding of the discussions and decisions made at this meeting. If you have any questions, additions or comments, please contact us at the above address. We will consider the minutes to be accurate unless written notice is received within 10 working days of the date issued.

The meeting began at approximately 2:30 p.m. and roughly followed the attached agenda. The handouts for the meeting are also an attachment to this document.

1. Jeff Novotny gave a brief introduction to the project, describing the limits, the scope of work, background information, related projects, project history, etc. and noted that presentations had recently been given to the MPO's CAC and TAC subcommittees. He explained that we were at the meeting as FDOT's representatives.
2. We went thru the handout sheets and discussed various topics in no particular order. Preliminary intersection designs were reviewed for US 41 at Symmes Road, Gibsonton Drive, Riverview Drive and Madison Avenue. Items discussed include:
  - a. We discussed how the South Coast Greenway could be accommodated along US 41 at the two river crossings. Charles asked if a 10-foot trail could be included on one side of the road in lieu of bike lanes on the shoulders, similar to what had been done on south US 301, due to high speeds on US 41. No PD&E study has been done yet for the portion of the South Coast Greenway planned to run along Symmes Road and to the north of Symmes Road.

- b. Symmes Road is shown at “two-lane enhanced” in the county’s Corridor Preservation Plan.
- c. Riverview Drive is proposed as “two-lane enhanced”
- d. Charles noted that the county is trying to 4-lane Madison, consistent with their corridor preservation plan. The Port may be planning to expand their access either at Madison or at a point to the south of the intersection.
- e. We noted that the design year for the future traffic conditions is 2040. We noted that county side street improvements needed to meet traffic LOS standards could be shown as “by others” on the concept plans. Where multiple left turn lanes are proposed on US 41 but the county side road doesn’t have the receiving lanes, FDOT could build the additional turn lanes on US 41 and stripe them out so that US 41 wouldn’t have to be widened again in the future.
- f. Staff asked about the status of the proposed rail grade separation on US 41 south of Causeway Blvd. *American will follow up with FDOT to find this out.*
- g. The county has no plans to improve Symmes Road.
- h. County staff is not aware of any plans for development in the Gibsonton area along US 41 or other areas along US 41 within our study limits, except for a proposed Dollar Store on the west side of US 41 near Symmes Road.
- i. The planned extension of Faulkenburg Road is for a private developer DRI.
- j. Mike Williams noted that having crash data to justify closings of median openings would make it a lot easier
- k. Jeff said that plan to coordinate with the Port and CSX regarding access issues, etc.
- l. Jeff noted that comments from the county can be sent to Kirk Bogen at FDOT
- m. Bob Campbell asked if ITS would be included in the cost estimate. He noted that the ITS Master Plan includes both FDOT and county roads.
- n. Jeff asked if staff were aware of any plans by utilities. The contact for the county is Kevin Moran in Public Utilities. Bob noted the presence of an ammonia pipeline in the project area. (*Note: according to my earlier notes, it starts at Pembroke [south of our project limits] and goes west along US 41 to St. Paul Street [between CSX crossing and Causeway Blvd.]. It is a 4-inch steel pipe at 3 to 5 feet depth. At the Alafia River, it is 39 feet deep-LRW*). Bob also mentioned that a jet fuel line is either existing or planned in the study area – the Port can provide more information on this.

The meeting ended at about 3:25 p.m.

Attachments